

翻印必究



上海雅马哈建设摩托车销售有限公司

<http://www.yamaha-motor.com.cn/>

第一版 2013年11月



SHANGHAI YAMAHA JIANSHE MOTOR MARKETING CO., LTD.

零件目录

YBR125E(13RU)
YBR125ESD(13RV)
YBR125EC(13RW)
YBR125ED(13RX)

13R-F8198-1M-MA

1M13R-415MA

天剑13 YBR125

YBR125E(13RU)/YBR125ESD(13RV)/YBR125EC(13RW)/YBR125ED(13RX)



13RU (鼓刹/辐条轮)

代号	颜色
0903	金属黑色



13RV (导流罩/碟刹/压铸轮)

代号	颜色
0903	金属黑色



13RW (鼓刹/压铸轮)

代号	颜色
0903	金属黑色



13RX (碟刹/压铸轮)

代号	颜色
0903	金属黑色



前言

本零件目录记载着封面页所示型号所使用的零件。当您订购更换零件时，请参阅本零件目录并正确指示零件号码和零件名称。

1. 零件目录发行后有变更或附加零件时，将会以雅马哈零件信息通知大家。
建议您应按照雅马哈零件信息修改本零件目录。

2. 省略记号
本文中所记载的省略记号的意思如下。

“UR” 需要指定的零件号码。

“UN” 需要数。

“AP” 选购品

“LM” 当地制造（必需于当地订购的零件）

“F#” 车架号（适用的机器号）

“O/S” 超过尺寸

3. 组件中部件的数量

- 组件的销售零件，如下所示，在零件名称的前面加上（.）的记号来表示。
- 每个部件右侧的数字表示各组件单体内该部件的数量。

零件号码	零件名称	数量	备注
2F5 - 83310 - 60	前闪光灯组合	2	
115 - 83311 - 60	. 灯泡 (6V - 18W)	1	

4. 适用的图形颜色表示在“备注”中，如下所示。

零件号码	零件名称	数量	备注
2N4 - 24110 - 00 - X5	燃油箱组件	2	MXR
3J1 - 24240 - 10	. 燃油箱图形	1	适用于 MXR

5. 请注意插图只用于找寻零件号码时参照，并不适用于组装。组装时，请使用适用的维修手册。

6. 在参照号码前的星号（*）表示其为在第一版后更改的项目。

前言

7. 适用的系列号码

车架系列号

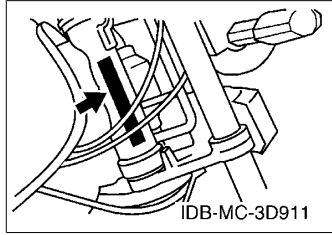

发动机系列号码

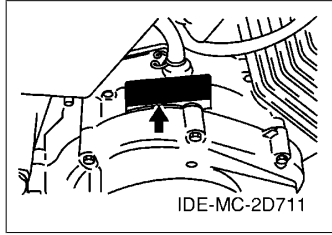

8. 适用的颜色记号 (*标志表示型号颜色。)

省略记号	颜色名称 (英文)	颜色名称	颜色记号
DBNM8	DARK BLUISH GRAY METALLIC 8	暗灰色	0919
NG	NEBURA GOLD	金色	008L
SL	SILVER	银色	0035
SMX(*)	BLACK METALLIC X	金属黑色	0903
YB	YAMAHA BLACK	雅马哈黑色	0033

9. 适用的初始系列号码

车架系列号

系列号码	数量栏名称	型号记号

发动机系列号码

系列号码	数量栏名称	型号记号

目录

发动机

气缸	1
曲柄·活塞	2
阀门	3
凸轮轴·链条	4
油泵	5
进气门	6
化油器	7
排气装置	8
曲轴箱	9
曲轴箱盖 1	10
起动离合器	11
离合器	12
传动	13
换挡凸轮·拨叉	15
变速杆	16
变速杆 2	17

车体

车架	18
挡泥板	19
侧盖	20
后臂·悬挂	21
操纵系统	22
操纵系统 2	23
前叉(鼓刹)	24
前叉(碟刹)	25
油箱	26
座位	28
前轮	29
前轮 2	31
前轮 3	32
前制动器卡钳	34
后轮	35
后轮 2	37
后轮 3	39
操纵手柄 钢索(鼓刹)	41
操纵手柄 钢索(碟刹)	42
前主缸	43
搁脚·支架	44

导流罩 1	46
发电机	47
起动电机	48
转向灯	49
仪表	50
前大灯	51
前大灯 2	52
尾灯	53
手柄开关(鼓刹)	54
手柄开关(碟刹)	55
电气系统 1	56
电气系统 2	57

索引

零件号码索引	58
--------	----

CONTENTS

ENGINE

CYLINDER.....	1
CRANKSHAFT & PISTON.....	2
VALVE.....	3
CAMSHAFT & CHAIN.....	4
OIL PUMP.....	5
INTAKE.....	6
CARBURETOR.....	7
EXHAUST.....	8
CRANKCASE.....	9
CRANKCASE COVER 1.....	10
STARTER CLUTCH.....	11
CLUTCH.....	12
TRANSMISSION.....	13
SHIFT CAM & FORK.....	15
SHIFT SHAFT.....	16
SHIFT SHAFT 2.....	17

CHASSIS

FRAME.....	18
FENDER.....	19
SIDE COVER.....	20
REAR ARM & SUSPENSION.....	21
STEERING.....	22
STEERING 2.....	23
FRONT FORK FOR DRUM BRAKE.....	24
FRONT FORK FOR DISK BRAKE.....	25
FUEL TANK.....	26
SEAT.....	28
FRONT WHEEL.....	29
FRONT WHEEL 2.....	31
FRONT WHEEL 3.....	32
FRONT BRAKE CALIPER.....	34
REAR WHEEL.....	35
REAR WHEEL 2.....	37
REAR WHEEL 3.....	39
STEERING CABLE FOR DRUM BRAKE.....	41
STEERING CABLE FOR DISK BRAKE.....	42
FRONT MASTER CYLINDER.....	43
STAND & FOOTREST.....	44

COWLING 1.....	46
GENERATOR.....	47
STARTING MOTOR.....	48
FLASHER LIGHT.....	49
METER.....	50
HEADLIGHT.....	51
HEADLIGHT 2.....	52
TAILLIGHT.....	53
SWITCH & LEVER FOR DRUM BRAKE.....	54
SWITCH & LEVER FOR DISK BRAKE.....	55
ELECTRICAL 1.....	56
ELECTRICAL 2.....	57

INDEX

NUMERICAL INDEX.....	58
----------------------	----

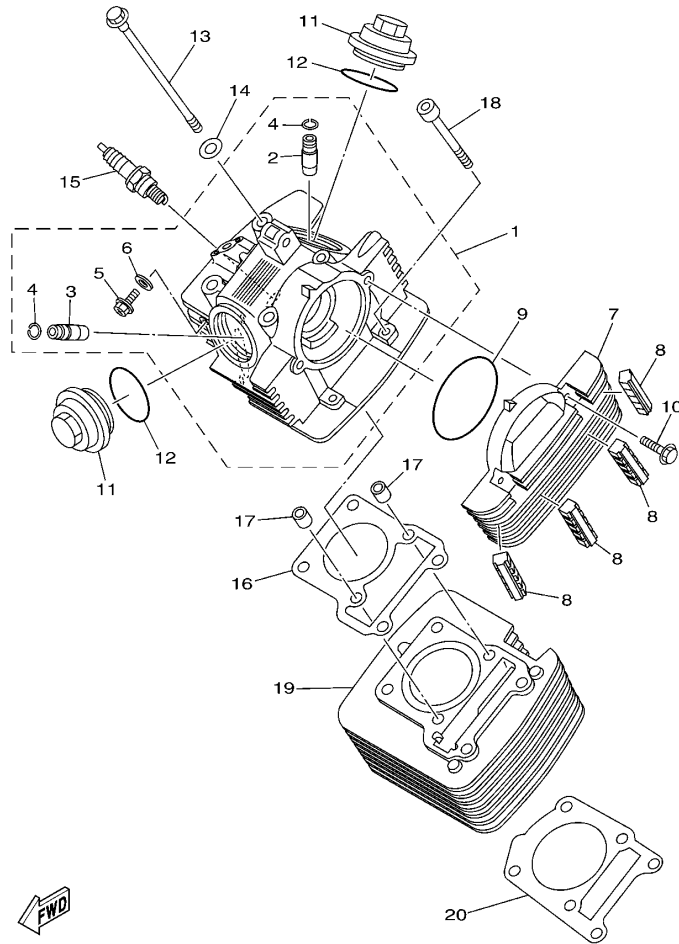

13RF415-L010

FIG. 1 气缸

CYLINDER

参照 号码	零件号码 PART NO.	零件名称 DESCRIPTION	13RU	13RV	13RW	13RX	备注 REMARKS
1	5VL-E1111-11	气缸头 1 HEAD, CYLINDER 1	1	1	1	1	
2	2UJ-11133-10	.进气门导管 .GUIDE, VALVE 1	1	1	1	1	
3	22F-11134-10	.排气门导管 .GUIDE, VALVE 2	1	1	1	1	
4	93440-10109	.卡环 .CIRCLIP	2	2	2	2	
5	90153-06803	.六角头螺钉 .SCREW, HEXAGON	1	1	1	1	
6	90430-06817	.衬垫 .GASKET	1	1	1	1	
7	5VL-E1185-10	气缸头侧盖 3 COVER, CYLINDER HEAD SIDE 3	1	1	1	1	
8	5VL-E1161-00	减震垫 1 ABSORBER 1	4	4	4	4	
9	93210-79802	0 型环 O-RING	1	1	1	1	
10	95022-06020	凸缘螺栓 BOLT, FLANGE	2	2	2	2	
11	5VL-E1186-00	气缸头侧盖 2 COVER, CYLINDER HEAD SIDE 2	2	2	2	2	
12	93210-44812	0 型环 O-RING	2	2	2	2	
13	90105-08724	凸缘螺栓 BOLT, FLANGE	4	4	4	4	
14	90201-088C3	平垫圈 WASHER, PLATE	4	4	4	4	
15	94700-00869	火花塞 PLUG SPARK (NGK CR6HSA)	1	1	1	1	
16	1BK-E1181-00	气缸头衬垫 1 GASKET, CYLINDER HEAD 1	1	1	1	1	
17	99530-10114	定位销 PIN, DOWEL	2	2	2	2	
18	91312-06090	螺栓 BOLT	2	2	2	2	
19	1BK-E1310-00	气缸 CYLINDER	1	1	1	1	
20	5VL-E1351-10	气缸衬垫 GASKET, CYLINDER	1	1	1	1	

FIG. 2 曲柄·活塞

CRANKSHAFT & PISTON

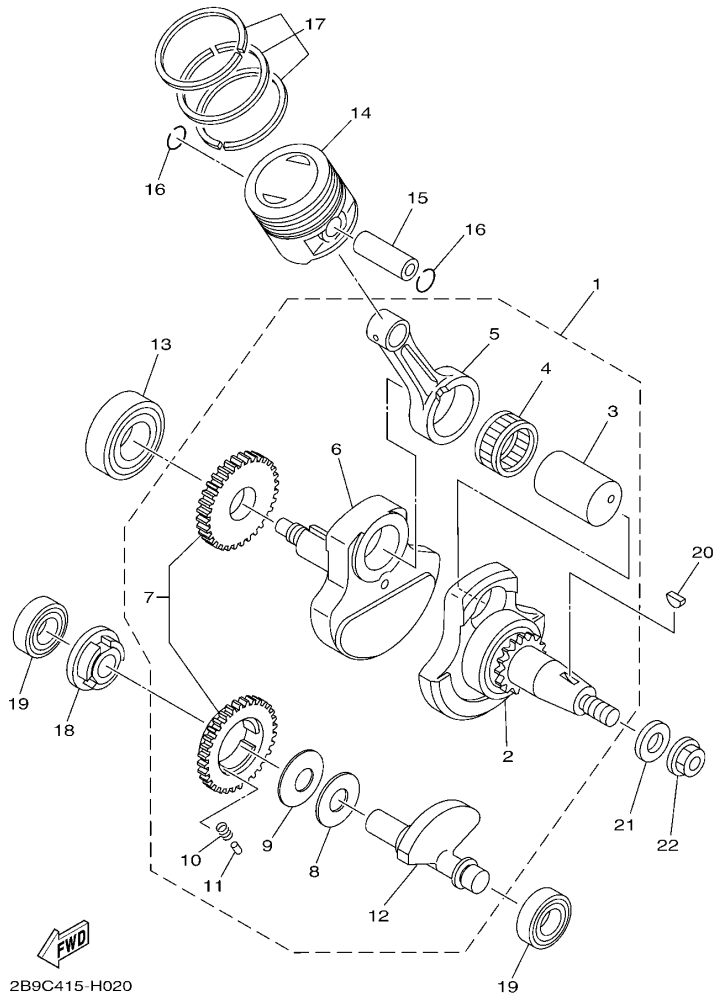

参照 号码	零件号码 PART NO.	零件名称 DESCRIPTION	13RU	13RV	13RW	13RX	备注 REMARKS
1	5VL-W1140-10	曲柄连杆组合 CRANKSHAFT ASSY	1	1	1	1	
2	5VL-W1141-10	.曲柄 1 .CRANK SUB ASSY 1	1	1	1	1	
3	5VL-E1681-00	.曲柄销 1 .PIN, CRANK 1	1	1	1	1	
4	93310-629Y3	.轴承 .BEARING	1	1	1	1	
5	5VL-E1651-00	.连杆 .ROD, CONNECTING	1	1	1	1	
6	5VL-E1422-00	.曲柄 2 .CRANK 2	1	1	1	1	
7	5VL-Y1153-20	.平衡齿轮总成 .GEAR, BALANCE WEIGHT ASSY.	1	1	1	1	
8	5VL-E1533-00	.减震板 .PLATE, ABSORBER	1	1	1	1	
9	90208-26800	.弹性挡圈 .WASHER, CONICAL SPRING	1	1	1	1	
10	90501-16001	.压簧 .SPRING, COMPRESSION	3	3	3	3	
11	93604-08800	.定位销 .PIN, DOWEL	3	3	3	3	
12	5VL-E1454-10	.平衡轴 1 .WEIGHT 1	1	1	1	1	
13	93306-205YP	轴承 BEARING	1	1	1	1	
14	5VL-E1631-00	活塞 (STD) PISTON (STD)	1	1	1	1	
15	5VL-E1633-00	活塞销 PIN, PISTON	1	1	1	1	
16	93450-16812	卡环 CIRCLIP	2	2	2	2	
17	5VL-W1161-00	活塞环套件 PISTON RING SET (STD)	1	1	1	1	
18	5VL-E1496-00	缓冲衬套 BOSS, BUFFER	1	1	1	1	
19	93306-202XN	轴承 BEARING	2	2	2	2	
20	90280-03017	半圆键 KEY, WOODRUFF	1	1	1	1	
21	90201-122H1	平垫圈 WASHER, PLATE	1	1	1	1	
22	90179-12863	螺母 NUT	1	1	1	1	

FIG. 3 阀门

VALVE

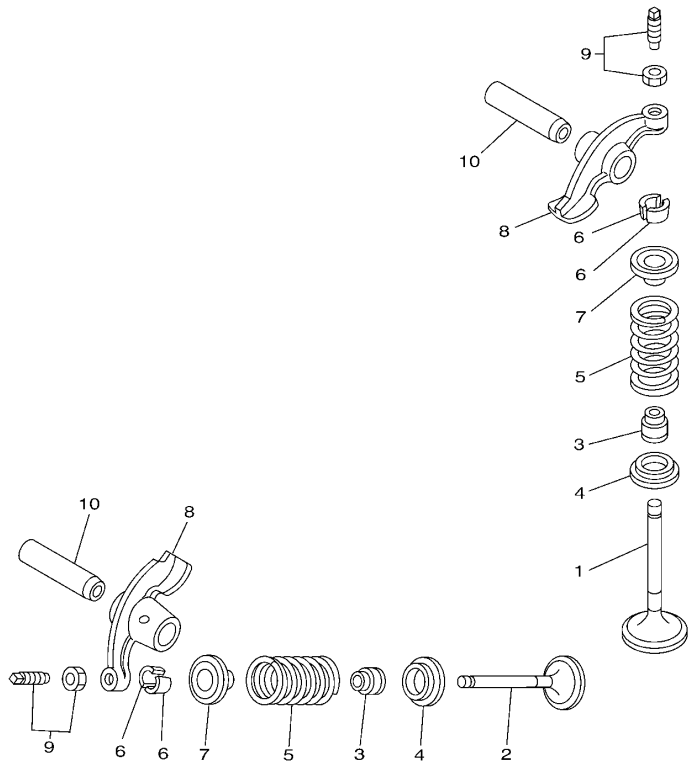

参照 号码	零件号码 PART NO.	零件名称 DESCRIPTION	13RU	13RV	13RW	13FX	备注 REMARKS
1	1BK-E2111-00	进气门 VALVE, INTAKE	1	1	1	1	
2	1BK-E2121-00	排气门 VALVE, EXHAUST	1	1	1	1	
3	1BK-E2119-00	气门油封 SEAL, VALVE STEM	2	2	2	2	
4	5VL-E2116-01	气门弹簧座 SEAT, VALVE SPRING	2	2	2	2	
5	1SF-E2113-00	气门内弹簧 SPRING, VALVE INNER	2	2	2	2	
6	5VL-E2118-00	气门锁夹 LOCK, VALVE SPRING RETAINER	4	4	4	4	
7	5VL-E2117-01	气门弹簧座 RETAINER, VALVE SPRING	2	2	2	2	
8	5VL-E2151-00	气门摇臂 ARM, VALVE ROCKER	2	2	2	2	
9	5VL-Y1215-00	气门调整螺栓组合 SCREW, VALVE ADJUSTING	2	2	2	2	
10	5VL-E2156-00	摇臂轴 2 SHAFT, ROCKER 2	2	2	2	2	

27S1300-G031

FIG. 4 凸轮轴·链条

CAMSHAFT & CHAIN

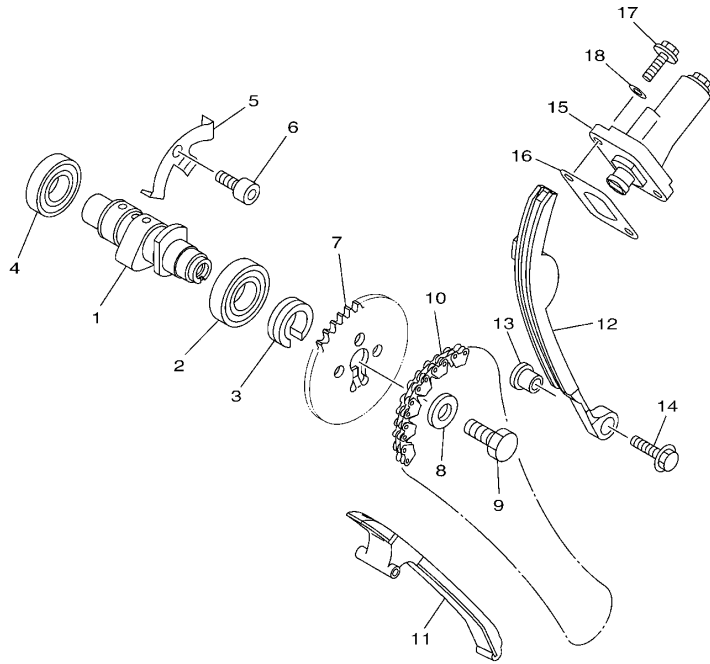

参照 号码	零件号码 PART NO.	零件名称 DESCRIPTION	13RU	13RV	13RW	13RX	备注 REMARKS
1	13R-E2171-00	凸轮轴 1 CAMSHAFT 1	1	1	1	1	
2	93306-003YS	轴承 BEARING	1	1	1	1	
3	90387-16804	轴套 COLLAR	1	1	1	1	
4	93306-002YM	轴承 BEARING	1	1	1	1	
5	5VL-E111F-00	面板 PLATE	1	1	1	1	
6	91312-06012	螺栓 BOLT	1	1	1	1	
7	5VL-E2176-10	链轮 SPROCKET, CAM CHAIN	1	1	1	1	
8	90201-08326	平垫圈 WASHER, PLATE	1	1	1	1	
9	90101-08820	螺栓 BOLT	1	1	1	1	
10	94568-A4090	链条 CHAIN	1	1	1	1	
11	5VL-E2231-10	导向限位板 1 GUIDE, STOPPER 1	1	1	1	1	
12	5VL-E2241-10	导向限位板 2 GUIDE, STOPPER 2	1	1	1	1	
13	5VL-E5598-00	衬套 COLLAR	1	1	1	1	
14	95802-06020	凸缘螺栓 BOLT, FLANGE	1	1	1	1	
15	5VL-12210-10	链条张紧器组合 TENSIONER ASSY, CAM CHAIN	1	1	1	1	
16	5VL-E2213-10	张紧器垫片 GASKET, TENSIONER CASE	1	1	1	1	
17	95022-06016	凸缘螺栓 BOLT, FLANGE	2	2	2	2	
18	90430-06817	衬垫 GASKET	2	2	2	2	

2B9F415-J040

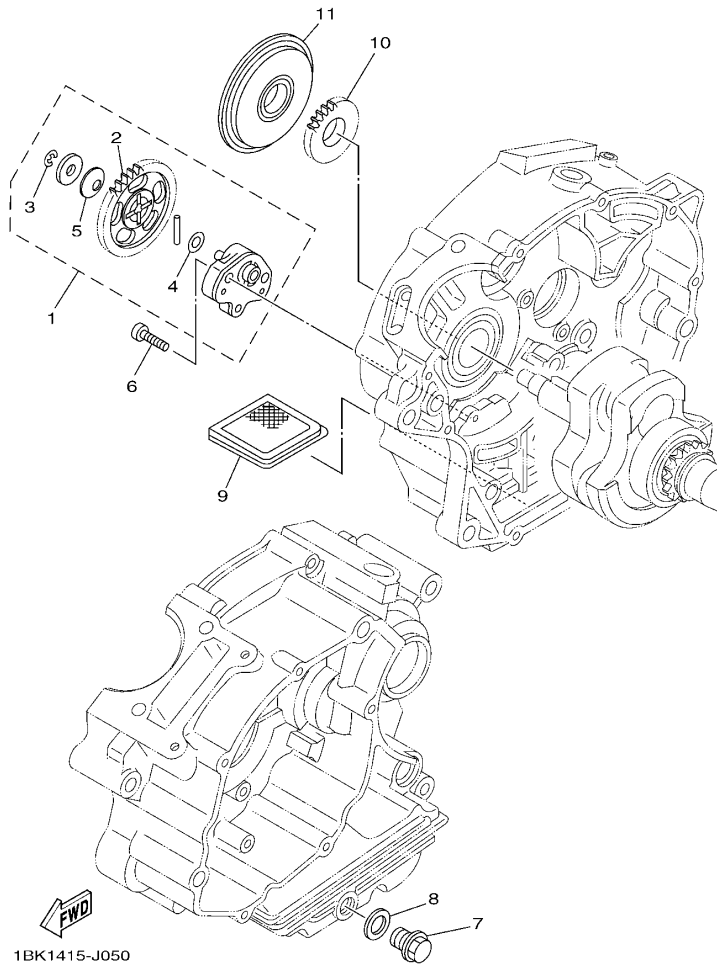

FIG. 5 油泵

OIL PUMP

参照 号码	零件号码 PART NO.	零件名称 DESCRIPTION	13RU	13RV	13RW	13RX	备注 REMARKS
1	5VL-E3300-01	机油泵总成 OIL PUMP ASSY	1	1	1	1	
2	5VL-E3325-00	从动齿轮 .GEAR, PUMP DRIVEN	1	1	1	1	
3	99002-05600	卡环 .CLIP	1	1	1	1	
4	90201-07641	平垫圈 .WASHER, PLATE	1	1	1	1	
5	90208-07052	弹性挡圈 .WASHER, CONICAL SPRING	1	1	1	1	
6	90155-06800	螺钉 SCREW, FLAT FILLISTER	2	2	2	2	
7	90340-12097	螺塞 PLUG, STRAIGHT SCREW	1	1	1	1	
8	90430-12227	衬垫 GASKET	1	1	1	1	
9	2D0-E3411-00	机油滤网 STRAINER, OIL	1	1	1	1	
10	5VL-E3324-00	机油泵驱动齿轮 GEAR, PUMP DRIVE	1	1	1	1	
11	5VL-E3451-00	转子过滤器 FILTER, ROTARY	1	1	1	1	

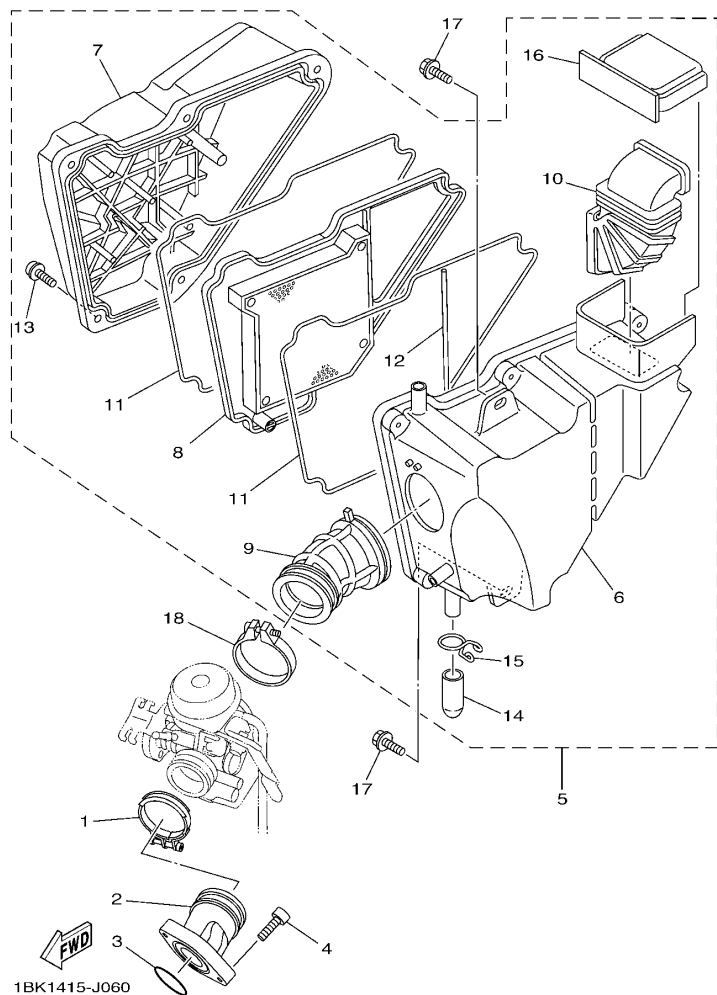

FIG. 6 进气门

INTAKE

参照 号码	零件号码 PART NO.	零件名称 DESCRIPTION	13RU	13RV	13RW	13RX	备注 REMARKS
1	90450-44804	软管夹组合 HOSE CLAMP ASSY	1	1	1	1	
2	18C-E3586-10	化油器接头 1 JOINT, CARBURETOR 1	1	1	1	1	
3	93210-30801	O型环 O-RING	1	1	1	1	
4	91312-06020	螺栓 BOLT	2	2	2	2	
5	1BK-E4410-00	空气净化器组合 AIR CLEANER ASSY.	1	1	1	1	
6	1BK-E4411-00	.空气净化器箱 1 .CASE, AIR CLEANER 1	1	1	1	1	
7	1BK-E4412-00	.空气净化器箱盖 1 .CAP, CLEANER CASE 1	1	1	1	1	
8	2D0-E4450-00	.空气净化器滤芯组合 .ELEMENT ASSY, AIR CLEANER	1	1	1	1	
9	1BK-E4453-00	.空气净化器接头 1 .JOINT, AIR CLEANER 1	1	1	1	1	
10	2D0-E4437-00	.导管 .DUCT	1	1	1	1	
11	2D0-E4452-00	.密封垫 .SEAL	2	2	2	2	
12	2D0-E4462-00	.密封垫 .SEAL	1	1	1	1	
13	97602-06220	.带垫圈大柱头螺钉 .SCREW, PAN HEAD W/WASHER	5	5	5	5	
14	2D0-E443E-00	.排水管 .PIPE, DRAIN	1	1	1	1	
15	2D0-E4424-00	.卡环 .CLIP, CAP FITTING	1	1	1	1	
16	2D0-E4417-00	.盖 1 .COVER 1	1	1	1	1	
17	90119-06869	带垫螺栓 BOLT, WITH WASHER	2	2	2	2	
18	18C-E3575-01	箍带 BAND	1	1	1	1	

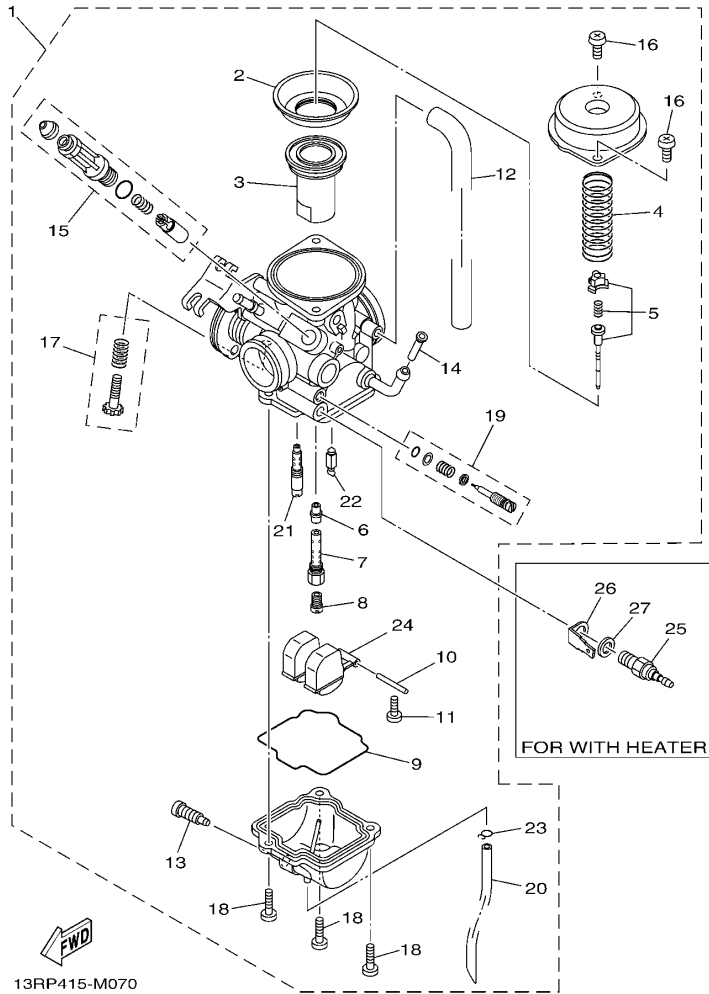
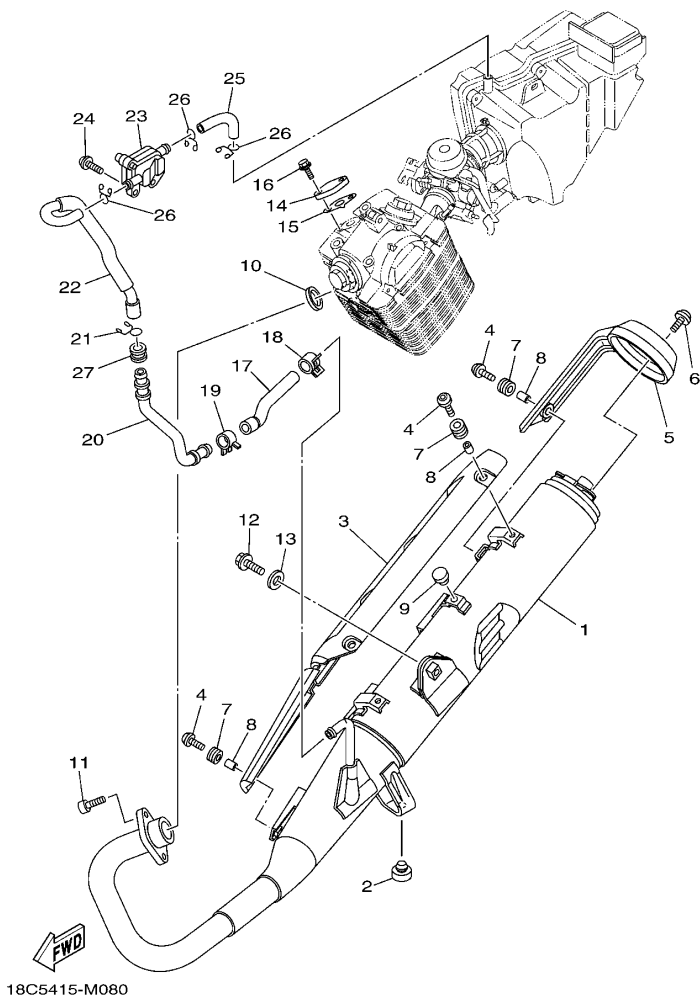

FIG. 7 化油器

CARBURETOR

参照 号码	零件号码 PART NO.	零件名称 DESCRIPTION	13RU	13RV	13RW	13RX	备注 REMARKS
1	1SF-E4901-02	化油器总成 1 CARBURETOR ASSY 1	1	1	1	1	
2	5LW-24411-00	.隔板 .DIAPHRAGM	1	1	1	1	
3	18D-14112-00	.节气门阀 1 .VALVE, THROTTLE 1	1	1	1	1	
4	18D-14589-10	.弹簧 .SPRING	1	1	1	1	
5	18C-1490J-00	.滚针套件 .NEEDLE SET	1	1	1	1	
6	5P0-14141-13	.主喷嘴 .NOZZLE, MAIN	1	1	1	1	
7	18C-14261-00	.支座 .HOLDER	1	1	1	1	
8	3G2-14231-22	.主量孔 (#110) .JET, MAIN (#110)	1	1	1	1	
9	5HK-14147-00	.O型环 .O-RING	1	1	1	1	
10	353-14186-00	.浮子销 .PIN, FLOAT	1	1	1	1	
11	98507-04008	.十字螺钉 .SCREW, PAN HEAD	2	2	2	2	
12	5YY-14197-00	.管 .PIPE	1	1	1	1	
13	5LW-14191-00	.排泄螺钉 .PLUG, DRAIN	1	1	1	1	
14	5LW-14994-00	.滤网 .NET, FILTER	1	1	1	1	
15	1SF-E410A-00	.起动机套件 .STARTER SET	1	1	1	1	
16	98507-05008	.十字螺钉 .SCREW, PAN HEAD	2	2	2	2	
17	5YY-14103-00	.节气门螺钉组件 .THROTTLE SCREW SET	1	1	1	1	
18	98507-04014	.十字螺钉 .SCREW, PAN HEAD	3	3	3	3	
19	18D-14105-00	.混合气调整螺钉组件 .PILOT SCREW SET	1	1	1	1	
20	18C-14196-00	.溢流管 1 .PIPE, OVER FLOW 1	1	1	1	1	
21	5P0-14142-17	.低速量孔 (#17.5) .JET, PILOT (#17.5)	1	1	1	1	
22	49P-14150-00	.针阀组件 .NEEDLE ASSY	1	1	1	1	
23	22F-14139-00	.管夹 .CLIP, PIPE	1	1	1	1	
24	18D-14985-00	.浮子 .FLOAT	1	1	1	1	
25	5FU-83790-00	加热器 HEATER ASSY (15W)	1	1	1	1	加热器车用
26	5FU-82103-00	接头 1 TERMINAL 1	1	1	1	1	加热器车用
27	5CY-14951-00	垫圈 WASHER	1	1	1	1	加热器车用



18C5415-M080

FIG. 8 排气装置

EXHAUST

参照 号码	零件号码 PART NO.	零件名称 DESCRIPTION	13RU	13RV	13RW	13RX	备注 REMARKS
1	18C-E4703-30	消音器组件 1 MUFFLER COMP. 1	1	1	1	1	
2	4TU-F4741-00	缓冲座 PAD, SEAT	1	1	1	1	
3	18C-E4758-00	消声器保护 PROTECTOR, SILENCER	1	1	1	1	
4	90149-06833	螺钉 SCREW	6	6	6	6	
5	18C-E4799-00	盖 CAP	1	1	1	1	
6	90111-06015	六角螺栓 BOLT, HEX. SOCKET BUTTON	3	3	3	3	
7	90480-12581	橡胶垫 GROMMET	6	6	6	6	
8	90387-06023	轴套 COLLAR	6	6	6	6	
9	2TY-F4181-00	定位减震器 1 DAMPER, LOCATING 1	1	1	1	1	
10	5VL-E4613-00	排气管衬垫 GASKET, EXHAUST PIPE	1	1	1	1	
11	91312-06020	螺栓 BOLT	2	2	2	2	
12	95812-08020	凸缘螺栓 BOLT, FLANGE	1	1	1	1	
13	90201-08840	平垫圈 WASHER, PLATE	1	1	1	1	
14	3D9-E113F-00	板 3 PLATE 3	1	1	1	1	
15	5VL-E4815-00	衬垫 GASKET	1	1	1	1	
16	95022-06016	凸缘螺栓 BOLT, FLANGE	2	2	2	2	
17	3D9-E4881-00	弯曲软管 1 HOSE, BEND 1	1	1	1	1	
18	90467-16807	卡环 CLIP	1	1	1	1	
19	90467-19801	卡环 CLIP	1	1	1	1	
20	18C-E4873-00	管 3 PIPE 3	1	1	1	1	
21	90467-18806	卡环 CLIP	1	1	1	1	
22	13R-E4882-00	弯曲软管 2 HOSE, BEND 2	1	1	1	1	
23	18D-E4803-00	二次进气系统 AIR INDUCTION SYSTEM ASSY	1	1	1	1	
24	92012-06012	螺钉 BOLT, BUTTON HEAD	2	2	2	2	
25	3D9-E4883-00	弯曲软管 3 HOSE, BEND 3	1	1	1	1	
26	90467-14802	卡环 CLIP	3	3	3	3	
27	90480-20M05	橡胶垫 GROMMET	1	1	1	1	

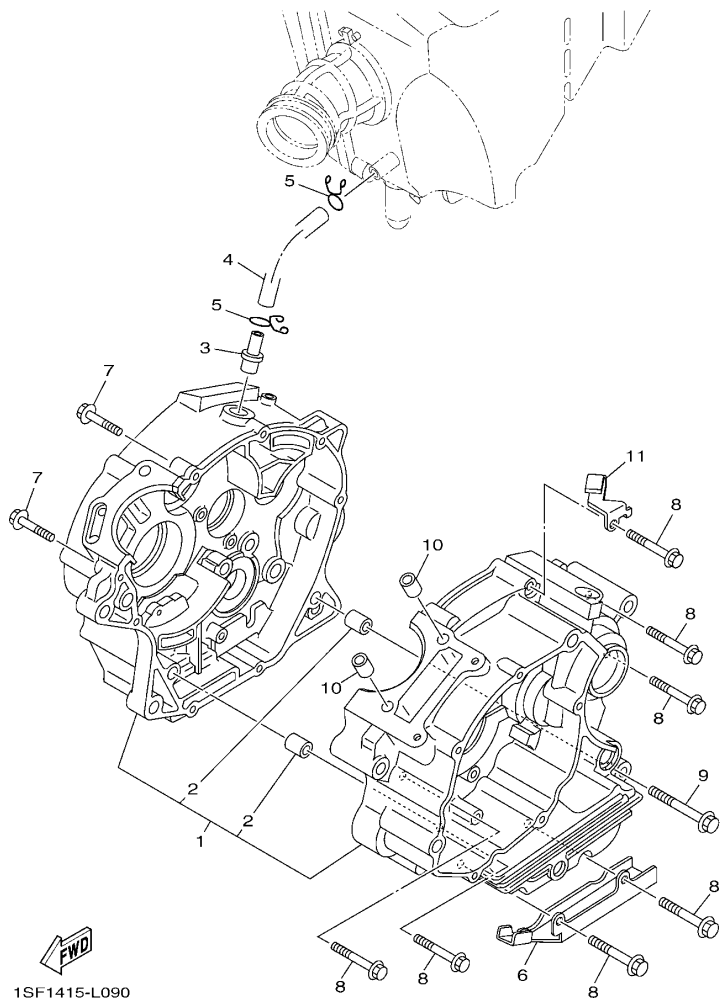

1SF1415-L090

FIG. 9 曲轴箱

CRANKCASE

参照 号码	零件号码 PART NO.	零件名称 DESCRIPTION	13RU	13RV	13RW	13RX	备注 REMARKS
1	1SF-W1510-00	曲轴箱组合 CRANKCASE ASSY	1	1	1	1	
2	99530-10114	.定位销 .PIN, DOWEL	2	2	2	2	
3	4FP-E1167-00	通气管 2 PIPE, BREATHER 2	1	1	1	1	
4	5VL-E1166-00	通气管 1 PIPE, BREATHER 1	1	1	1	1	
5	90467-12828	卡环 CLIP	2	2	2	2	
6	90462-16801	线夹 CLAMP	1	1	1	1	
7	95022-06030	凸缘螺栓 BOLT, FLANGE	2	2	2	2	
8	95022-06045	凸缘螺栓 BOLT, FLANGE	7	7	7	7	
9	95022-06055	凸缘螺栓 BOLT, FLANGE	1	1	1	1	
10	99530-10114	定位销 PIN, DOWEL	2	2	2	2	
11	5VL-E5441-01	离合器钢索支架 HOLDER, CLUTCH CABLE	1	1	1	1	

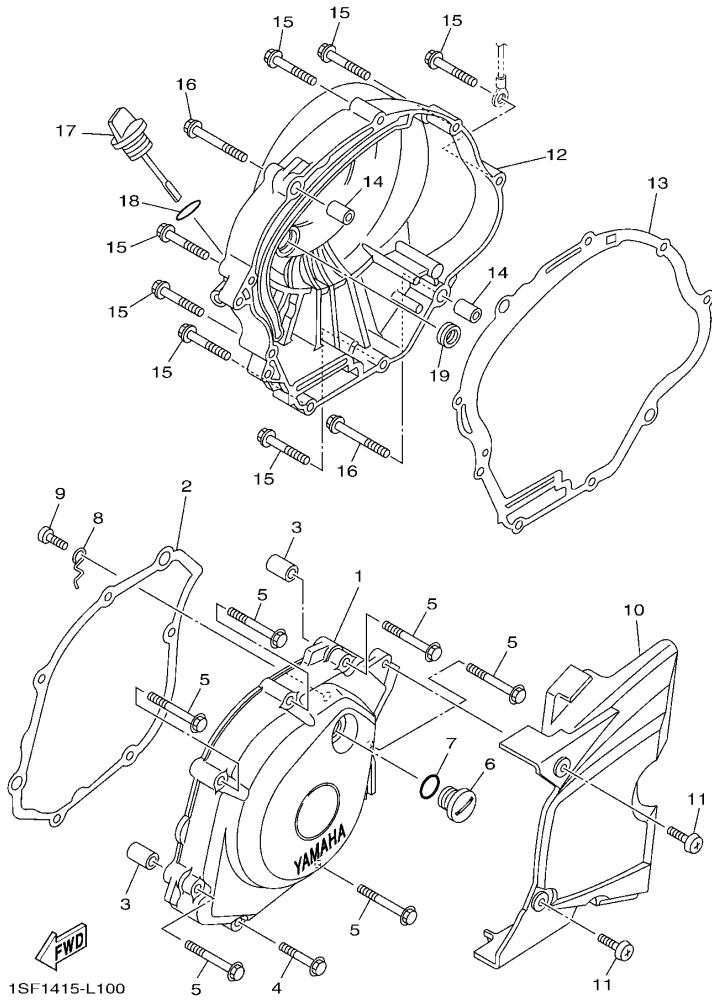

FIG. 10 曲轴箱盖 1

CRANKCASE COVER 1

参照 号码	零件号码 PART NO.	零件名称 DESCRIPTION	13RU	13RV	13RW	13RX	备注 REMARKS
1	1SF-E5411-00	曲轴箱盖 1 COVER, CRANKCASE 1	1	1	1	1	
2	5VL-E5451-10	曲轴箱盖衬垫 1 GASKET, CRANKCASE COVER 1	1	1	1	1	
3	99530-10114	定位销 PIN, DOWEL	2	2	2	2	
4	95022-06035	凸缘螺栓 BOLT, FLANGE	1	1	1	1	
5	95022-06050	凸缘螺栓 BOLT, FLANGE	6	6	6	6	
6	90340-14810	螺塞 PLUG, STRAIGHT SCREW	1	1	1	1	
7	93210-14817	O 型环 O-RING	1	1	1	1	
8	5VL-E5191-00	面板 PLATE	1	1	1	1	
9	98512-06010	十字螺钉 SCREW, PAN HEAD	1	1	1	1	
10	18C-E5418-00	链条箱盖 COVER, CHAIN CASE	1	1	1	1	
11	98902-06016	十字槽盘头螺钉 SCREW, BIND	2	2	2	2	
12	1SF-E5421-00	曲轴箱盖 2 COVER, CRANKCASE 2	1	1	1	1	
13	5VL-E5461-10	曲轴箱盖衬垫 2 GASKET, CRANKCASE COVER 2	1	1	1	1	
14	99530-10114	定位销 PIN, DOWEL	2	2	2	2	
15	95022-06035	凸缘螺栓 BOLT, FLANGE	7	7	7	7	
16	95022-06045	凸缘螺栓 BOLT, FLANGE	2	2	2	2	
17	5VL-E5362-00	油标塞 PLUG, OIL LEVEL	1	1	1	1	
18	93210-19809	O 型环 O-RING	1	1	1	1	
19	93101-10800	油封 OIL SEAL	1	1	1	1	

FIG. 11 起动离合器

STARTER CLUTCH

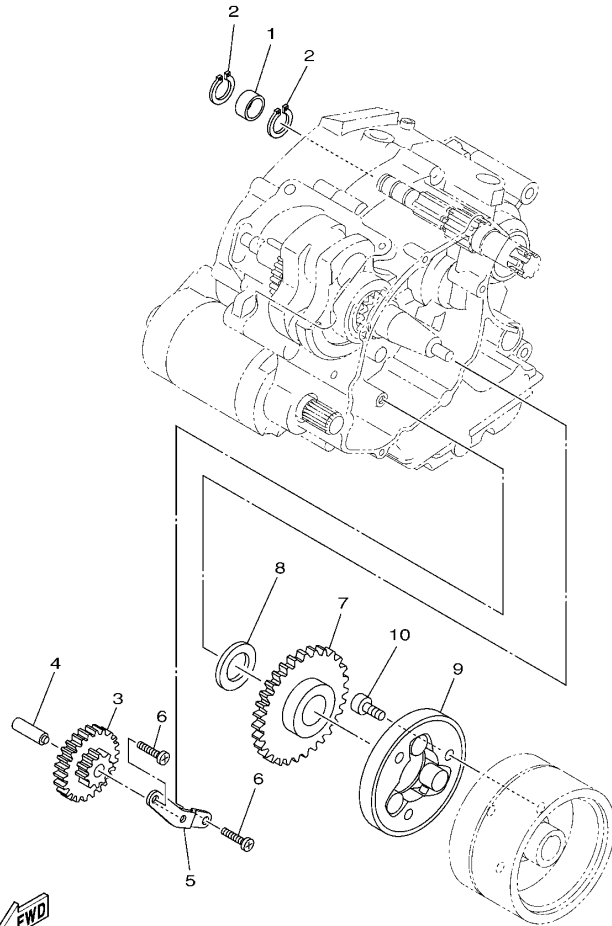

13RF415-L111

参照 号码	零件号码 PART NO.	零件名称 DESCRIPTION	13RU	13RV	13RW	13RX	备注 REMARKS
1	90387-15803	轴套 COLLAR	1	1	1	1	
2	99009-15400	卡环 CIRCLIP	2	2	2	2	
3	5VL-E5512-00	惰齿轮 1 GEAR, IDLER 1	1	1	1	1	
4	5VL-E5521-00	轴 1 SHAFT 1	1	1	1	1	
5	5VL-E5532-00	惰齿轮面板 PLATE, IDLE GEAR	1	1	1	1	
6	98512-06012	十字螺钉 SCREW, PAN HEAD	2	2	2	2	
7	5VL-E5517-00	惰齿轮 2 GEAR, IDLER 2	1	1	1	1	
8	90201-258D7	平垫圈 WASHER, PLATE	1	1	1	1	
9	1BK-E5580-00	起动离合器外部组合 STARTER CLUTCH OUTER ASSY	1	1	1	1	
10	91312-08016	螺栓 BOLT	3	3	3	3	

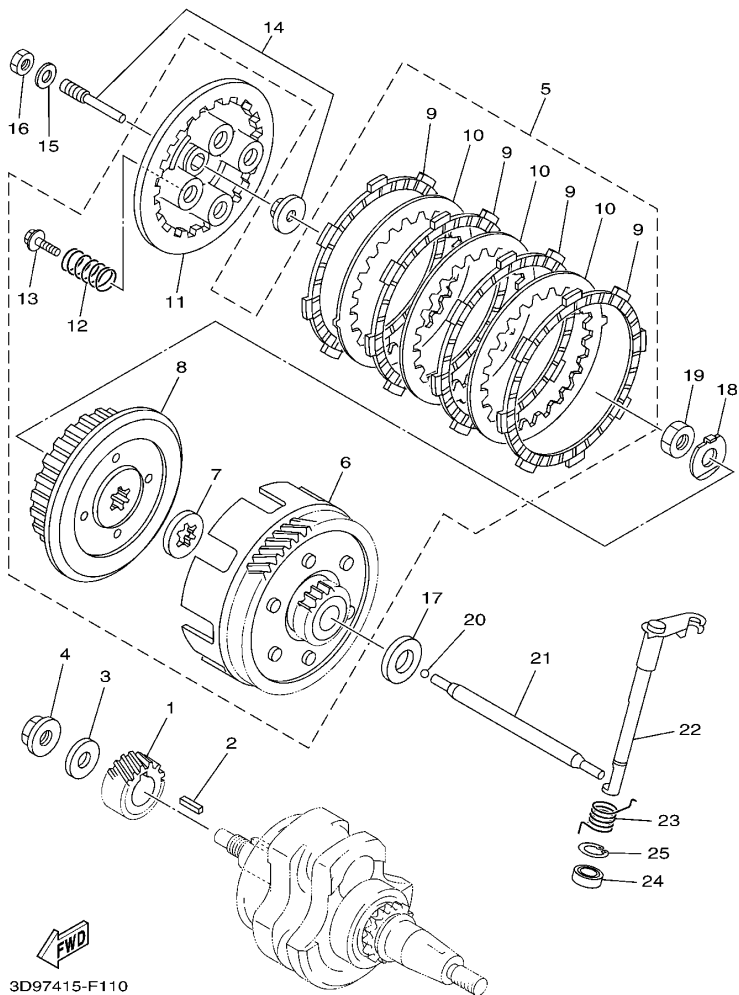

3D97415-F110

FIG. 12 离合器

CLUTCH

参照 号码	零件号码 PART NO.	零件名称 DESCRIPTION	13RU	13RV	13RW	13RX	备注 REMARKS
1	1JP-E6111-00	初级驱动齿轮 GEAR, PRIMARY DRIVE	1	1	1	1	
2	90282-05001	平键 KEY, STRAIGHT (5MMX16MM)	1	1	1	1	
3	90201-122H1	平垫圈 WASHER, PLATE	1	1	1	1	
4	90179-12813	螺母 NUT	1	1	1	1	
5	1JP-E6300-10	离合器总成 CLUTCH ASSY	1	1	1	1	
6	1JP-E6150-10	.从动齿轮组合 .PRIMARY DRIVEN GEAR COMP.	1	1	1	1	
7	1JP-E6154-00	.推板 1 .PLATE, THRUST 1	1	1	1	1	
8	1JP-E6371-00	.离合器轮毂 .BOSS, CLUTCH	1	1	1	1	
9	1JP-E6321-00	.摩擦片 .PLATE, FRICTION	4	4	4	4	
10	1JP-E6324-00	.离合器片 1 .PLATE, CLUTCH 1	3	3	3	3	
11	1JP-E6351-00	.压板 1 .PLATE, PRESSURE 1	1	1	1	1	
12	1JP-E6333-00	.离合器弹簧 1 .SPRING, CLUTCH 1	4	4	4	4	
13	1JP-E6337-00	.弹簧螺钉 .SCREW, SPRING	4	4	4	4	
14	5VL-Y1635-10	推杆组合 PUSH LEVER COMP.	1	1	1	1	
15	92902-06200	垫圈 WASHER	1	1	1	1	
16	95302-06600	螺母 NUT	1	1	1	1	
17	5VL-E6164-10	推板 2 PLATE, THRUST 2	1	1	1	1	
18	90215-12211	制动垫圈 WASHER, LOCK	1	1	1	1	
19	90170-12060	螺母 NUT	1	1	1	1	
20	93503-16824	钢球 BALL	1	1	1	1	
21	5VL-E6357-01	推杆 2 ROD, PUSH 2	1	1	1	1	
22	5VL-E6381-02	推杆组合 PUSH LEVER COMP.	1	1	1	1	
23	90508-16800	扭簧 SPRING, TORSION	1	1	1	1	
24	93102-12812	油封 OIL SEAL	1	1	1	1	
25	99009-20500	卡环 CIRCLIP	1	1	1	1	

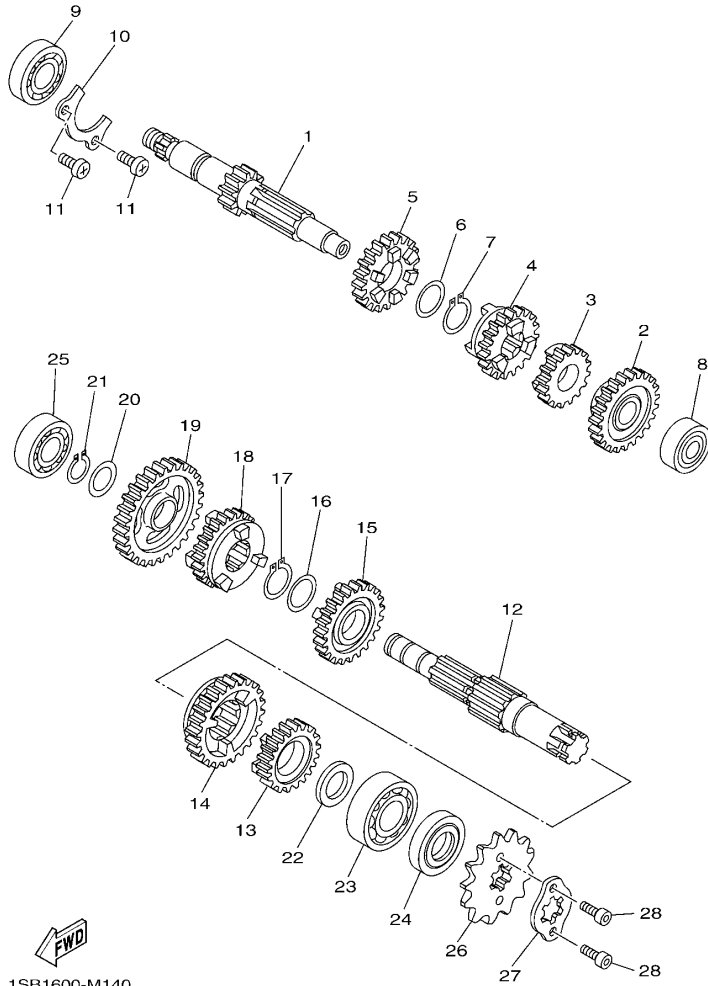

1SB1600-M140

FIG. 13 传动

TRANSMISSION

参照 号码	零件号码 PART NO.	零件名称 DESCRIPTION	13RU	13RV	13RW	13RX	备注 REMARKS
1	5VL-E7411-00	主轮轴 AXLE, MAIN (14T)	1	1	1	1	
2	5VL-E7151-00	五档主动齿轮 GEAR, 5TH PINION (24T)	1	1	1	1	
3	5VL-E7121-00	二档主动齿轮 GEAR, 2ND PINION (18T)	1	1	1	1	
4	5VL-E7131-00	三档主动齿轮 GEAR, 3RD PINION (19T)	1	1	1	1	
5	5VL-E7141-00	四档主动齿轮 GEAR, 4TH PINION (22T)	1	1	1	1	
6	90201-20266	平垫圈 WASHER, PLATE (T=1.0)	1	1	1	1	
7	93410-20809	卡环 CIRCLIP	1	1	1	1	
8	93306-201Y8	轴承 BEARING	1	1	1	1	
9	93306-203YT	轴承 BEARING	1	1	1	1	
10	5VL-E7471-00	盖板 PLATE, COVER	1	1	1	1	
11	98512-06012	十字螺钉 SCREW, PAN HEAD	2	2	2	2	
12	5VL-E7402-00	驱动轮轴组合 DRIVE AXLE ASSY	1	1	1	1	
13	5VL-E7251-00	五档从动齿轮 GEAR, 5TH WHEEL (21T)	1	1	1	1	
14	5VL-E7221-00	二档从动齿轮 GEAR, 2ND WHEEL (32T)	1	1	1	1	
15	5VL-E7231-00	三档从动齿轮 GEAR, 3RD WHEEL (25T)	1	1	1	1	
16	90201-20266	平垫圈 WASHER, PLATE (T=1.0)	1	1	1	1	
17	93410-20809	卡环 CIRCLIP	1	1	1	1	
18	5VL-E7241-00	四档从动齿轮 GEAR, 4TH WHEEL (23T)	1	1	1	1	
19	5VL-E7211-00	一档从动齿轮 GEAR, 1ST WHEEL (37T)	1	1	1	1	
20	90201-15700	平垫圈 WASHER, PLATE	1	1	1	1	
21	99009-15400	卡环 CIRCLIP	1	1	1	1	
22	90201-20272	平垫圈 WASHER, PLATE	1	1	1	1	
23	93306-204YD	轴承 BEARING	1	1	1	1	
24	93102-20812	油封 OIL SEAL	1	1	1	1	
25	93306-202XP	轴承 BEARING	1	1	1	1	
26	93822-14813	驱动链轮 SPROCKET, DRIVE (14T)	1	1	1	1	
27	3D9-E7456-01	驱动链轮挡圈 HOLDER, SPROCKET	1	1	1	1	

FIG. 13 传动

TRANSMISSION

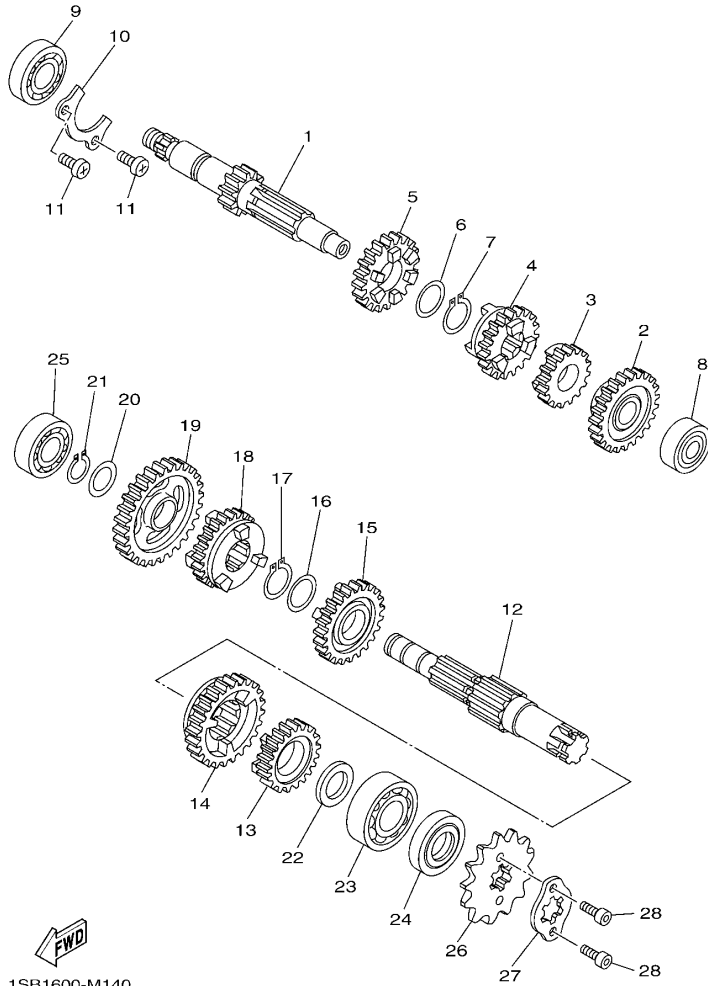

1SB1600-M140

参照 号码	零件号码 PART NO.	零件名称 DESCRIPTION	13RU	13RV	13RW	13RX	备注 REMARKS
28	91312-05010	螺栓 BOLT	2	2	2	2	

FIG. 14 换挡凸轮·拨叉

SHIFT CAM & FORK

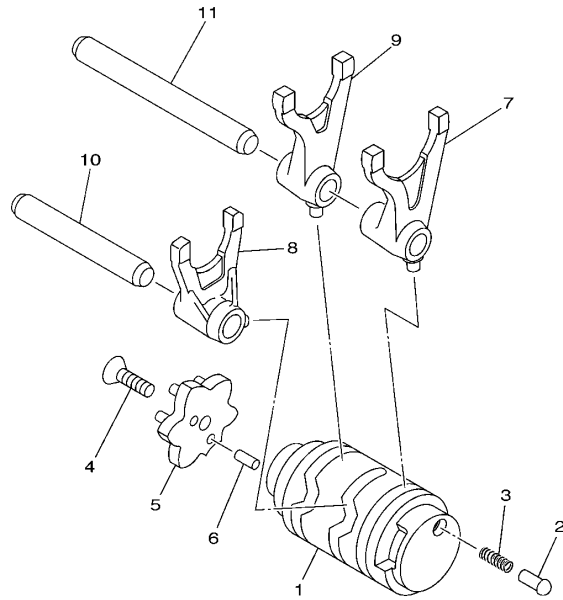

参照 号码	零件号码 PART NO.	零件名称 DESCRIPTION	13RU	13RV	13RW	13RX	备注 REMARKS
1	1SF-E8541-00	换挡凸轮轴 CAM, SHIFT	1	1	1	1	
2	1JD-E8542-00	端子 POINT, NEUTRAL	1	1	1	1	
3	90501-06805	压簧 SPRING, COMPRESSION	1	1	1	1	
4	90151-06818	沉头螺钉 SCREW, COUNTERSUNK	1	1	1	1	
5	1BK-E8185-00	星形轮 SEGMENT	1	1	1	1	
6	93604-10837	定位销 PIN, DOWEL	2	2	2	2	
7	2D0-E8511-00	换挡拨叉 1 FORK, SHIFT 1	1	1	1	1	
8	2D0-E8512-00	换挡拨叉 2 FORK, SHIFT 2	1	1	1	1	
9	2D0-E8513-00	换挡拨叉 3 FORK, SHIFT 3	1	1	1	1	
10	5VL-E8531-00	拨叉导杆 1 BAR, SHIFT FORK GUIDE 1	1	1	1	1	
11	5VL-E8535-00	拨叉导杆 2 BAR, SHIFT FORK GUIDE 2	1	1	1	1	



13RF415-L140

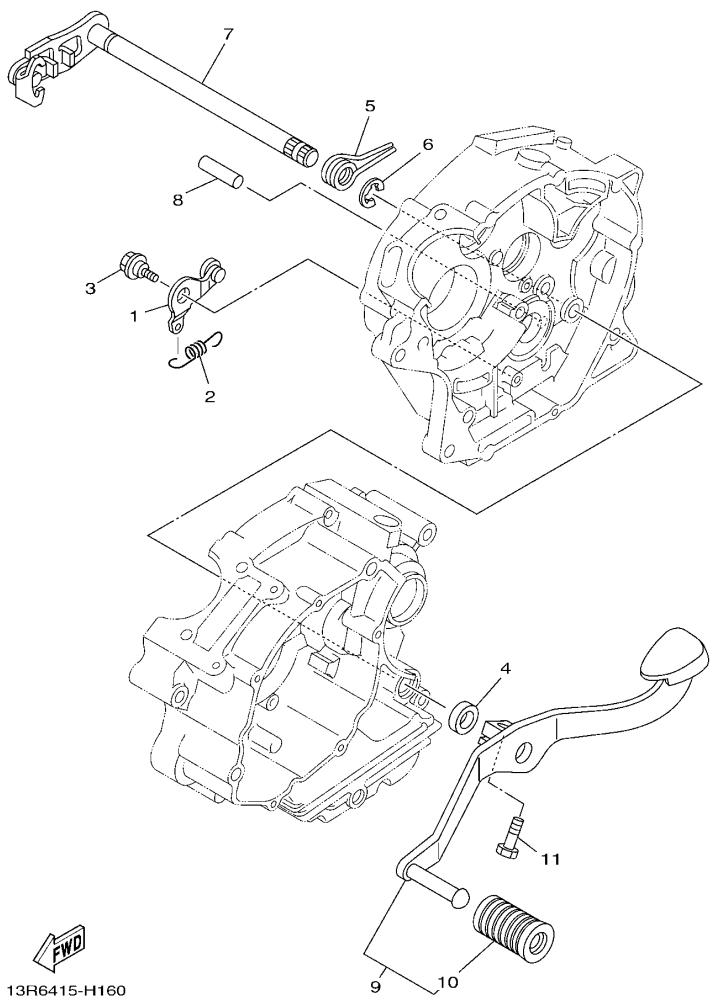

13R6415-H160

FIG. 15 变速杆

SHIFT SHAFT

参照 号码	零件号码 PART NO.	零件名称 DESCRIPTION	13RU	13RV	13RW	13RX	备注 REMARKS
1	5VL-E8140-00	限位杆组合 STOPPER LEVER ASSY	1		1	1	
2	5VL-E8337-00	弹簧 SPRING	1		1	1	
3	4FP-E8177-00	限位杆螺栓 BOLT, STOPPER	1		1	1	
4	93101-12803	油封 OIL SEAL	1		1	1	
5	90508-32801	扭簧 SPRING, TORSION	1		1	1	
6	99002-10600	卡环 CLIP	1		1	1	
7	5VL-E8101-12	变速杆总成 SHIFT SHAFT ASSY	1		1	1	
8	93608-30839	定位销 PIN, DOWEL	1		1	1	
9	5VL-E8110-12	换挡踏板组合 SHIFT PEDAL ASSY	1		1	1	
10	1KL-E8113-00	换挡踏板套 COVER, SHIFT PEDAL	1		1	1	
11	97022-06020	螺栓 BOLT, HEXAGON	1		1	1	

FIG. 16 变速杆 2

SHIFT SHAFT 2

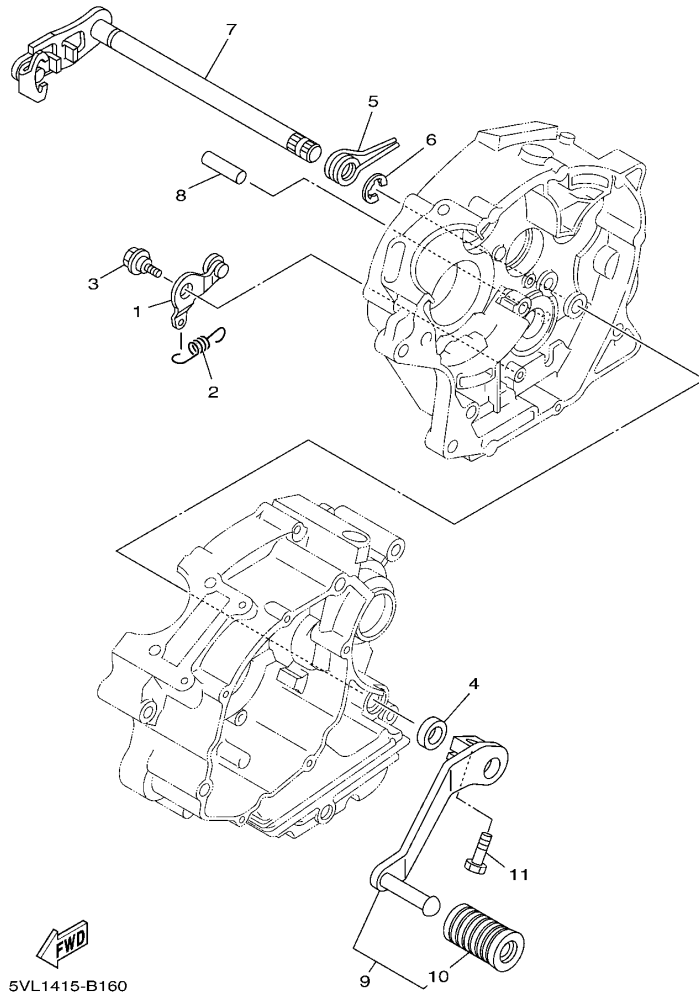

参照 号码	零件号码 PART NO.	零件名称 DESCRIPTION	13RU	13RV	13RW	13RX	备注 REMARKS
1	5VL-E8140-00	限位杆组合 STOPPER LEVER ASSY		1			
2	5VL-E8337-00	弹簧 SPRING		1			
3	4FP-E8177-00	限位杆螺栓 BOLT, STOPPER		1			
4	93101-12803	油封 OIL SEAL		1			
5	90508-32801	扭簧 SPRING, TORSION		1			
6	99002-10600	卡环 CLIP		1			
7	5VL-E8101-12	变速杆总成 SHIFT SHAFT ASSY		1			
8	93608-30839	定位销 PIN, DOWEL		1			
9	5VL-E8110-01	换挡踏板组合 SHIFT PEDAL ASSY		1			
10	1KL-E8113-00	换挡踏板套 COVER, SHIFT PEDAL		1			
11	97022-06020	螺栓 BOLT, HEXAGON		1			

FIG. 17 车架

FRAME

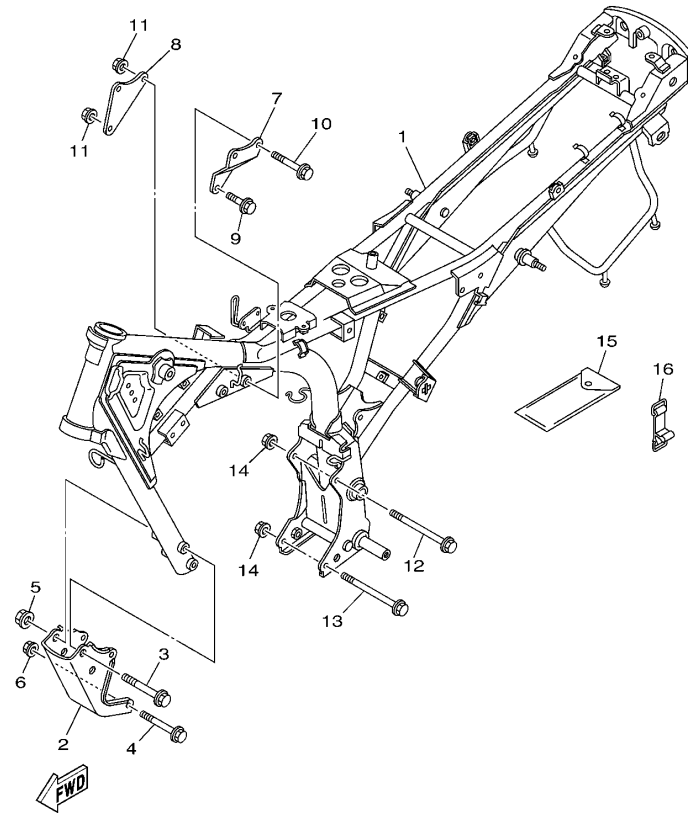

13RF415-L170

参照 号码	零件号码 PART NO.	零件名称 DESCRIPTION	13RU	13RV	13RW	13RX	备注 REMARKS
1	13R-F1110-20	车架组合 FRAME COMP.	1		1	1	
	13R-F1110-30	车架组合 FRAME COMP.		1			
2	1BK-F1316-00	发动机支承 2 STAY, ENGINE 2	1	1	1	1	
3	95812-10080	凸缘螺栓 BOLT, FLANGE	2	2	2	2	
4	90105-08874	凸缘螺栓 BOLT, FLANGE	2	2	2	2	
5	90179-10807	螺母 NUT	2	2	2	2	
6	90179-08830	螺母 NUT	2	2	2	2	
7	5VL-F1317-00	发动机支承 3 STAY, ENGINE 3	1	1	1	1	
8	5VL-F1318-00	发动机支承 5 STAY, ENGINE 5	1	1	1	1	
9	90105-088E4	凸缘螺栓 BOLT, FLANGE	1	1	1	1	
10	90105-088E5	凸缘螺栓 BOLT, FLANGE	2	2	2	2	
11	90179-08830	螺母 NUT	3	3	3	3	
12	90105-08873	凸缘螺栓 BOLT, FLANGE	1	1	1	1	
13	90105-088E6	凸缘螺栓 BOLT, FLANGE	1	1	1	1	
14	90179-08830	螺母 NUT	2	2	2	2	
15	5VL-F8100-10	随车工具 TOOL KIT	1	1	1	1	
16	5VL-F811G-01	箍带 BAND	1	1	1	1	

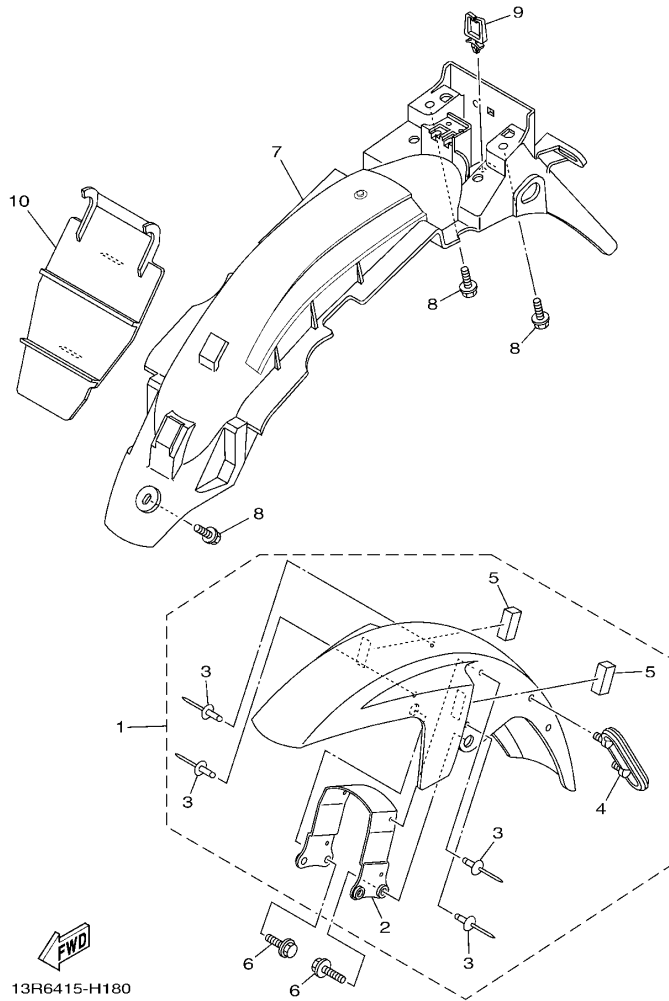
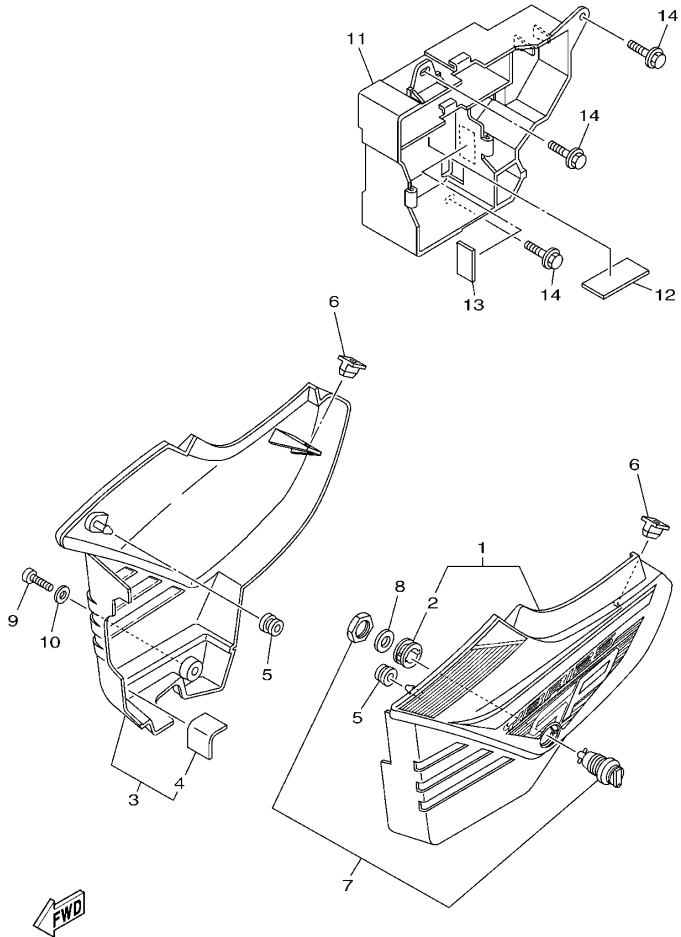

FIG. 18 挡泥板

FENDER

参照 号码	零件号码 PART NO.	零件名称 DESCRIPTION	13RU	13RV	13RW	13RX	备注 REMARKS
1	5VL-Y2151-03-P3	前挡泥板 FRONT FENDER ASSY	1	1	1	1	金属黑色车用 FOR SMX
2	5VL-F1513-01	.挡泥板支架 1 .STAY, FENDER 1	1	1	1	1	
3	90267-48854	.铆钉 .RIVET, BLIND	4	4	4	4	
4	5VL-F1518-01	.钢索支架 .HOLDER, CABLE	1	1	1	1	
5	5VL-F1541-00	.减震垫 1 .DAMPER 1	2	2	2	2	
6	95822-06016	凸缘螺栓 BOLT, FLANGE	4	4	4	4	
7	3D9-F1611-10	后挡泥板 FENDER, REAR	1	1	1	1	
8	90119-06869	带垫螺栓 BOLT, WITH WASHER	3	3	3	3	
9	90464-12803	线夹 CLAMP	1	1	1	1	
10	5VL-F1621-00	挡板 FLAP	1	1	1	1	



13RU415-M190

FIG. 19 侧盖

SIDE COVER

参照 号码	零件号码 PART NO.	零件名称 DESCRIPTION	13RU	13RV	13RW	13RX	备注 REMARKS
1	5VL-Y2171-44-3X	侧盖 1 COVER, SIDE 1	1		1	1	金属黑色车用 FOR SMX
	5VL-Y2171-51-3X	侧盖 1 COVER, SIDE 1		1			金属黑色车用 FOR SMX
2	90480-24186	橡胶垫 .GROMMET	1	1	1	1	
3	3D9-Y2172-40-3X	侧盖 2 COVER, SIDE 2	1	1	1	1	金属黑色车用 FOR SMX
4	13R-F1746-00	减震垫 .DAMPER	1	1	1	1	
5	90480-13837	橡胶垫 GROMMET	2	2	2	2	
6	5VL-F1778-00	定位减震器 1 DAMPER, LOCATING 1	2	2	2	2	
7	5VL-F1780-01	锁紧装置组合 LOCK ASSY	1	1	1	1	
8	90201-228F6	平垫圈 WASHER, PLATE	1	1	1	1	
9	98902-06020	十字槽盘头螺钉 SCREW, BIND	1	1	1	1	
10	90201-06850	平垫圈 WASHER, PLATE	1	1	1	1	
11	3D9-F177G-01	蓄电池盒 BOX, BATTERY	1	1	1	1	
12	5VL-F1746-00	减震垫 DAMPER	1	1	1	1	
13	3D9-F1747-00	减震垫 DAMPER	1	1	1	1	
14	90119-06811	带垫螺栓 BOLT, WITH WASHER	3	3	3	3	

FIG. 20 后臂·悬挂

REAR ARM & SUSPENSION

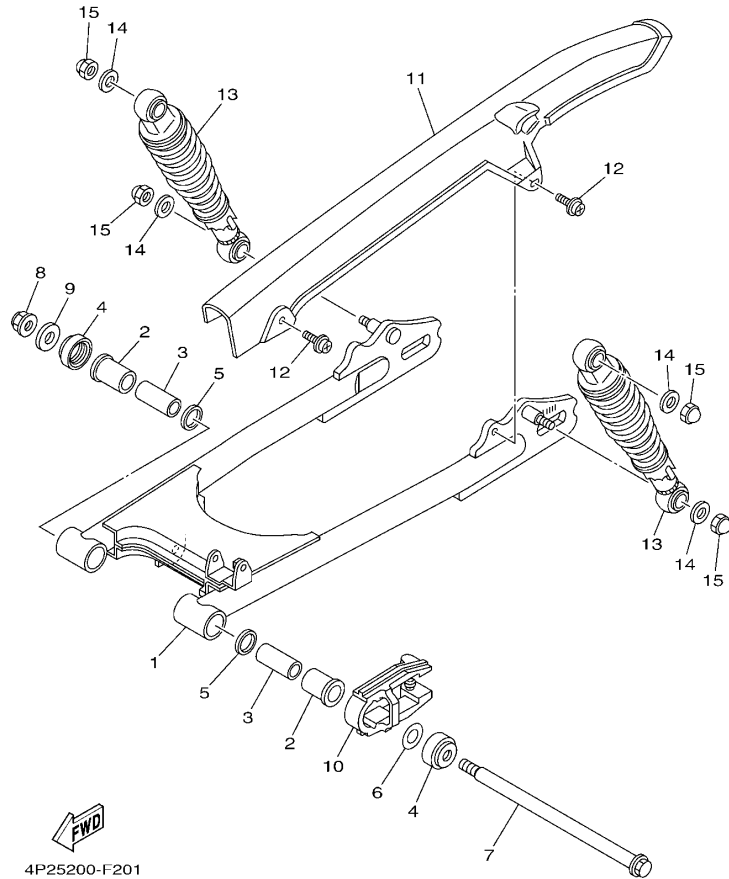

4P25200-F201

参照 号码	零件号码 PART NO.	零件名称 DESCRIPTION	13RU	13RV	13RW	13RX	备注 REMARKS
1	5VL-F2110-00-33	后臂组合 REAR ARM COMP.	1	1	1	1	雅马哈黑色 金属黑色车用 YB FOR SMX
2	90386-18801	衬套 BUSH	2	2	2	2	
3	5VL-F2123-00	衬套 1 BUSH 1	2	2	2	2	
4	5VL-F2128-01	推力盖 1 COVER, THRUST 1	2	2	2	2	
5	93109-18804	油封 OIL SEAL	2	2	2	2	
6	5VL-F2127-00	垫片 SHIM	1	1	1	1	UN UN
7	5VL-F2141-01	后臂转轴 SHAFT, PIVOT	1	1	1	1	
8	95602-12200	自锁螺母 NUT, SELF-LOCKING	1	1	1	1	
9	90201-12819	平垫圈 WASHER, PLATE	1	1	1	1	
10	5VL-F2151-10	链条保护套 SEAL, GUARD	1	1	1	1	
11	5VL-F2311-00	链盒 CASE, CHAIN	1	1	1	1	
12	90159-06830	带垫螺钉 SCREW, WITH WASHER	2	2	2	2	
13	5VL-F2210-01	后减震器组合 SHOCK ABSORBER ASSY, REAR	2	2	2	2	
14	90201-108C7	平垫圈 WASHER, PLATE	4	4	4	4	
15	90176-10810	盖型螺母 NUT, CROWN	4	4	4	4	

FIG. 21 操纵系统

STEERING

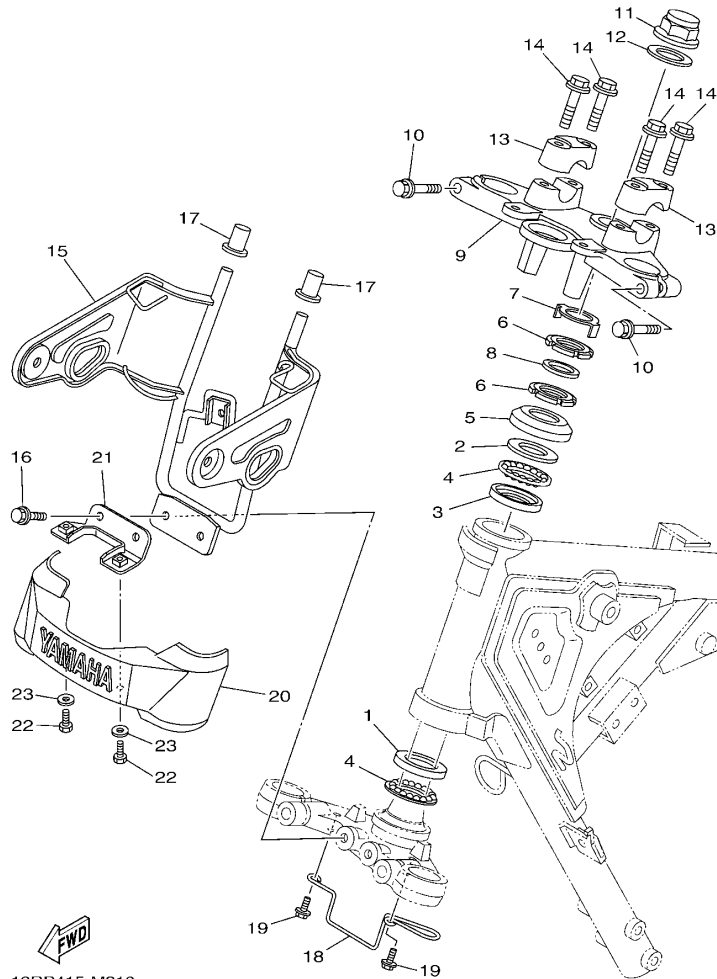

13RP415-M210

参照 号码	零件号码 PART NO.	零件名称 DESCRIPTION	13RU	13RV	13RW	13RX	备注 REMARKS
1	1KL-F3412-00	滚珠座圈 2 RACE, BALL 2	1		1	1	
2	4FP-F3411-00	滚珠座圈 1 RACE, BALL 1	1		1	1	
3	4FP-F3412-00	滚珠座圈 2 RACE, BALL 2	1		1	1	
4	5VL-F341E-10	保持架 RETAINER, BALL BEARING	2		2	2	
5	4GU-F3416-00	滚珠座圈盖 2 COVER, BALL RACE 2	1		1	1	
6	90179-25806	螺母 NUT	2		2	2	
7	5VL-F3418-01	专用垫圈 WASHER, SPECIAL	1		1	1	
8	90202-26142	平垫圈 WASHER, PLATE	1		1	1	
9	5VL-F3435-00-35	手把座 CROWN, HANDLE	1		1	1	银色 金属黑色车用 SL FOR SMX
10	95022-08040	凸缘螺栓 BOLT, FLANGE	2		2	2	
11	90176-22802	盖型螺母 NUT, CROWN	1		1	1	
12	5VL-F3165-01	垫圈 WASHER, FELT	1		1	1	
13	3S9-F3441-00	手把上夹持器 HOLDER, HANDLE UPPER	2		2	2	
14	95022-08035	凸缘螺栓 BOLT, FLANGE	4		4	4	
15	13R-F3174-11	前照灯支承 STAY, HEADLIGHT	1		1		
	13R-F3174-21	前照灯支承 STAY, HEADLIGHT				1	
16	95822-06016	凸缘螺栓 BOLT, FLANGE	2		2	2	
17	4FP-F317J-00	减震套 1 DAMPER 1	2		2	2	
18	5VL-F3389-01	钢索导框 GUIDE, CABLE	1		1	1	
19	95822-06012	凸缘螺栓 BOLT, FLANGE	2		2	2	
20	4FP-F3395-10	标牌 EMBLEM	1		1	1	
21	5VL-F334G-11	支承 1 BRACKET 1	1		1	1	
22	97002-05012	螺栓 BOLT	2		2	2	
23	90201-05802	平垫圈 WASHER, PLATE	2		2	2	

FIG. 22 操纵系统 2

STEERING 2

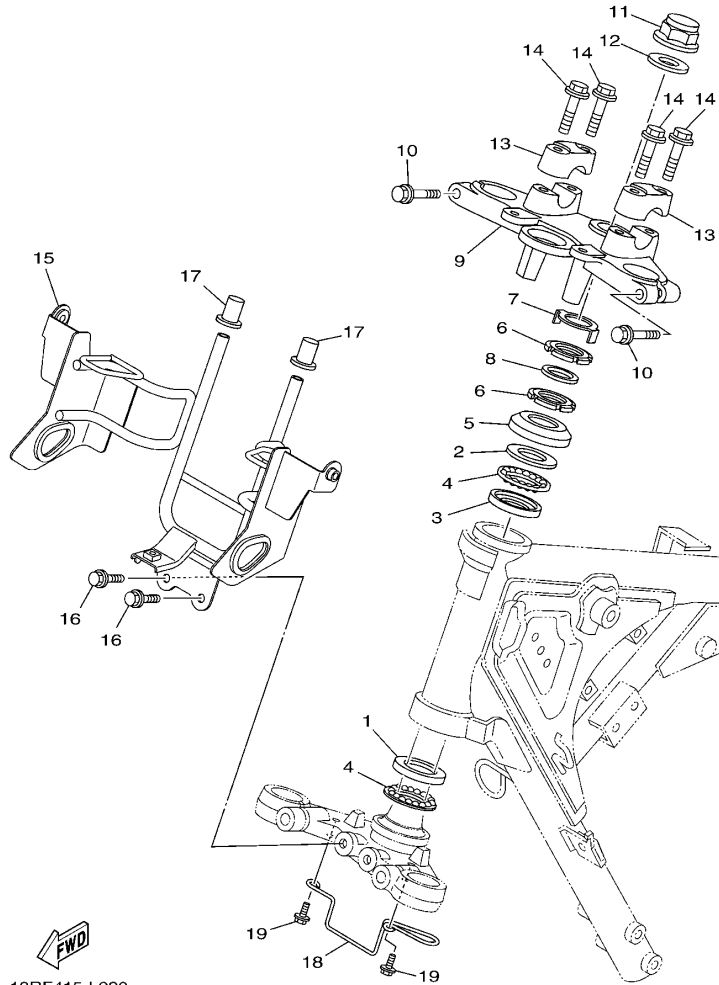

13RF415-L220

参照 号码	零件号码 PART NO.	零件名称 DESCRIPTION	13RU	13RV	13RW	13RX	备注 REMARKS
1	1KL-F3412-00	滚珠座圈 2 RACE, BALL 2		1			
2	4FP-F3411-00	滚珠座圈 1 RACE, BALL 1		1			
3	4FP-F3412-00	滚珠座圈 2 RACE, BALL 2		1			
4	5VL-F341E-10	保持架 RETAINER, BALL BEARING		2			
5	4GU-F3416-00	滚珠座圈盖 2 COVER, BALL RACE 2		1			
6	90179-25806	螺母 NUT		2			
7	5VL-F3418-01	专用垫圈 WASHER, SPECIAL		1			
8	90202-26142	平垫圈 WASHER, PLATE		1			
9	5VL-F3435-00-35	手把座 CROWN, HANDLE		1			银色 金属黑色车用 SL FOR SMX
10	95022-08040	凸缘螺栓 BOLT, FLANGE		2			
11	90176-22802	盖型螺母 NUT, CROWN		1			
12	5VL-F3165-01	垫圈 WASHER, FELT		1			
13	3S9-F3441-00	手把上夹持器 HOLDER, HANDLE UPPER		2			
14	95022-08035	凸缘螺栓 BOLT, FLANGE		4			
15	13R-F3174-00	前照灯支承 STAY, HEADLIGHT		1			
16	95822-06016	凸缘螺栓 BOLT, FLANGE		2			
17	4FP-F317J-00	减震套 1 DAMPER 1		2			
18	5VL-F3389-01	钢索导框 GUIDE, CABLE		1			
19	95822-06012	凸缘螺栓 BOLT, FLANGE		2			

FIG. 23 前叉(鼓刹)

FRONT FORK FOR DRUM BRAKE

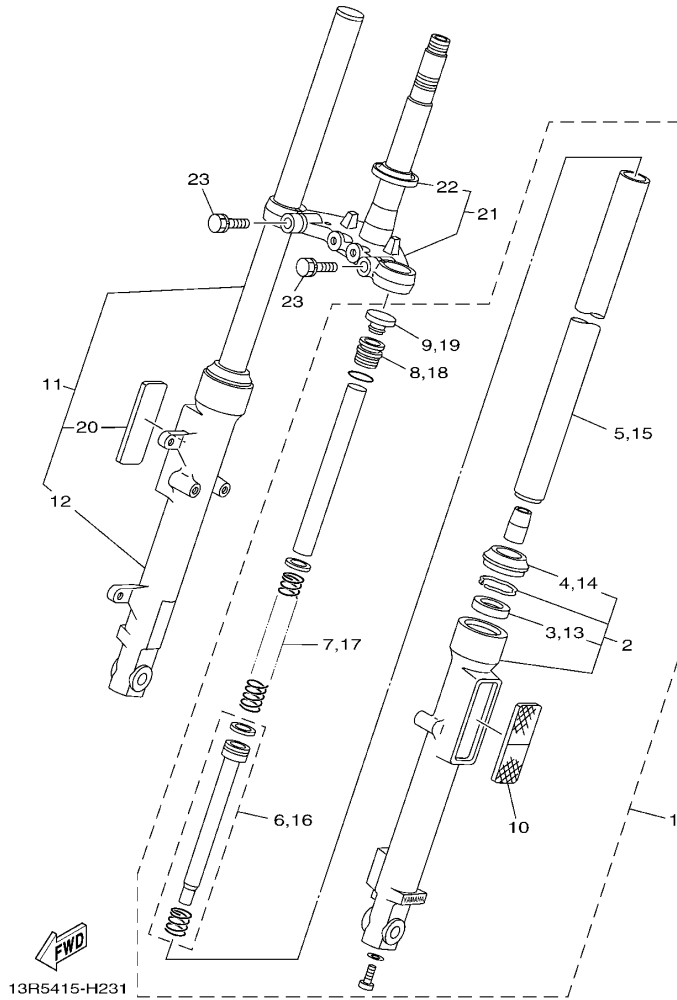

参照 号码	零件号码 PART NO.	零件名称 DESCRIPTION	13RU	13RV	13RW	13RX	备注 REMARKS
1	13R-F3102-00	前叉组合(左边) FRONT FORK ASSY (L.H)	1		1		
2	13R-F3106-00	.外管组件(左边) .OUTER TUBE COMP.	1		1		
3	4GU-F3145-00	.油封 .OIL SEAL	1		1		
4	4GU-F3144-00	.防尘罩 .SEAL, DUST	1		1		
5	5VL-F3110-01	.内管组件 1 .INNER TUBE COMP.1	1		1		
6	5VL-F3170-01	.前叉气缸组合 .CYLINDER COMP., FRONT FORK	1		1		
7	5VL-F3141-40	.前叉弹簧 .SPRING, FRONT FORK	1		1		
8	5VL-F3111-20	.顶盖螺栓 .BOLT, CAP	1		1		
9	5VL-F3154-00	.支承轴 .CAP	1		1		
10	5VL-H5110-30	.反射镜组合 .REFLECTOR ASSY	1		1		
11	13R-F3103-00	前叉组合(右边) FRONT FORK ASSY (R.H)	1		1		
12	13R-F3107-00	.外管组件(右边) .OUTER TUBE COMP. (R.H)	1		1		
13	4GU-F3145-00	.油封 .OIL SEAL	1		1		
14	4GU-F3144-00	.防尘罩 .SEAL, DUST	1		1		
15	5VL-F3110-01	.内管组件 1 .INNER TUBE COMP.1	1		1		
16	5VL-F3170-01	.前叉气缸组合 .CYLINDER COMP., FRONT FORK	1		1		
17	5VL-F3141-40	.前叉弹簧 .SPRING, FRONT FORK	1		1		
18	5VL-F3111-20	.顶盖螺栓 .BOLT, CAP	1		1		
19	5VL-F3154-00	.支承轴 .CAP	1		1		
20	5VL-H5110-30	.反射镜组合 .REFLECTOR ASSY	1		1		
21	5VL-F331X-01	下侧托架 BRACKET, UNDER	1		1		
22	4FP-F3411-10	.滚珠座圈 1 .RACE, BALL 1	1		1		
23	5VL-F3346-01	螺栓 1 BOLT 1	2		2		

FIG. 24 前叉(碟刹)

FRONT FORK FOR DISK BRAKE

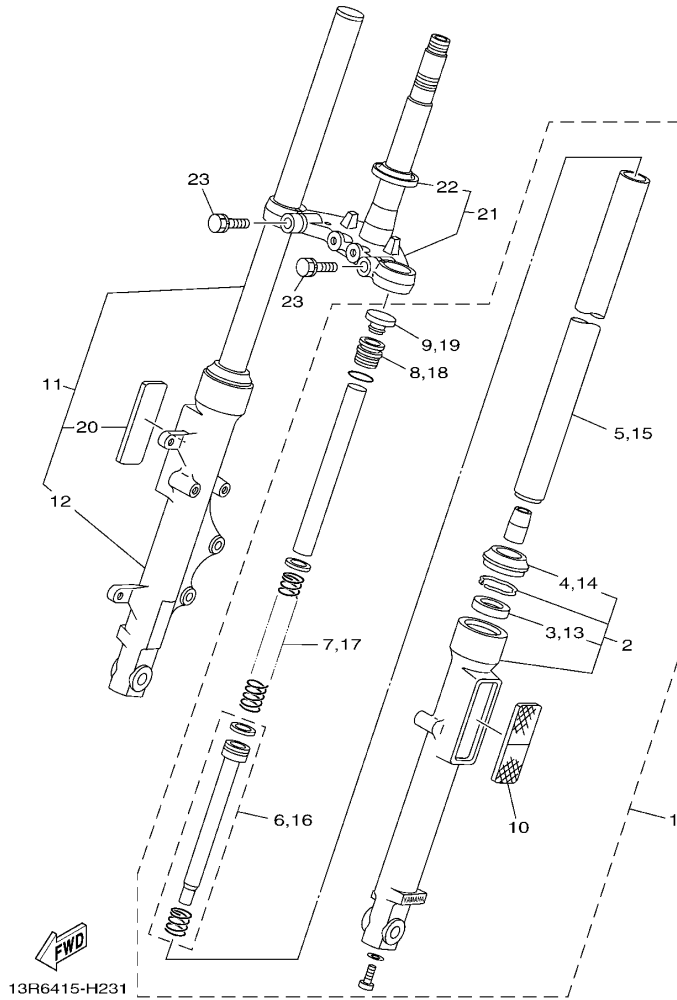

参照 号码	零件号码 PART NO.	零件名称 DESCRIPTION	13RU	13RV	13RW	13RX	备注 REMARKS
1	13R-F3102-10	前叉组合(左边) FRONT FORK ASSY (L.H)		1		1	
2	13R-F3106-10	.外管组件(左边) .OUTER TUBE COMP.		1		1	
3	4GU-F3145-00	.油封 .OIL SEAL		1		1	
4	4GU-F3144-00	.防尘罩 .SEAL, DUST		1		1	
5	5VL-F3110-01	.内管组件1 .INNER TUBE COMP.1		1		1	
6	5VL-F3170-01	.前叉气缸组合 .CYLINDER COMP., FRONT FORK		1		1	
7	5VL-F3141-40	.前叉弹簧 .SPRING, FRONT FORK		1		1	
8	5VL-F3111-20	.顶盖螺栓 .BOLT, CAP		1		1	
9	5VL-F3154-00	.支承轴 .CAP		1		1	
10	5VL-H5110-30	.反射镜组合 .REFLECTOR ASSY		1		1	
11	13R-F3103-10	前叉组合(右边) FRONT FORK ASSY (R.H)		1		1	
12	13R-F3107-10	.外管组件(右边) .OUTER TUBE COMP. (R.H)		1		1	
13	4GU-F3145-00	.油封 .OIL SEAL		1		1	
14	4GU-F3144-00	.防尘罩 .SEAL, DUST		1		1	
15	5VL-F3110-01	.内管组件1 .INNER TUBE COMP.1		1		1	
16	5VL-F3170-01	.前叉气缸组合 .CYLINDER COMP., FRONT FORK		1		1	
17	5VL-F3141-40	.前叉弹簧 .SPRING, FRONT FORK		1		1	
18	5VL-F3111-20	.顶盖螺栓 .BOLT, CAP		1		1	
19	5VL-F3154-00	.支承轴 .CAP		1		1	
20	5VL-H5110-30	.反射镜组合 .REFLECTOR ASSY		1		1	
21	5VL-F331X-01	下侧托架 BRACKET, UNDER		1		1	
22	4FP-F3411-10	.滚珠座圈1 .RACE, BALL 1		1		1	
23	5VL-F3346-01	螺栓1 BOLT 1		2		2	

FIG. 25 油箱

FUEL TANK

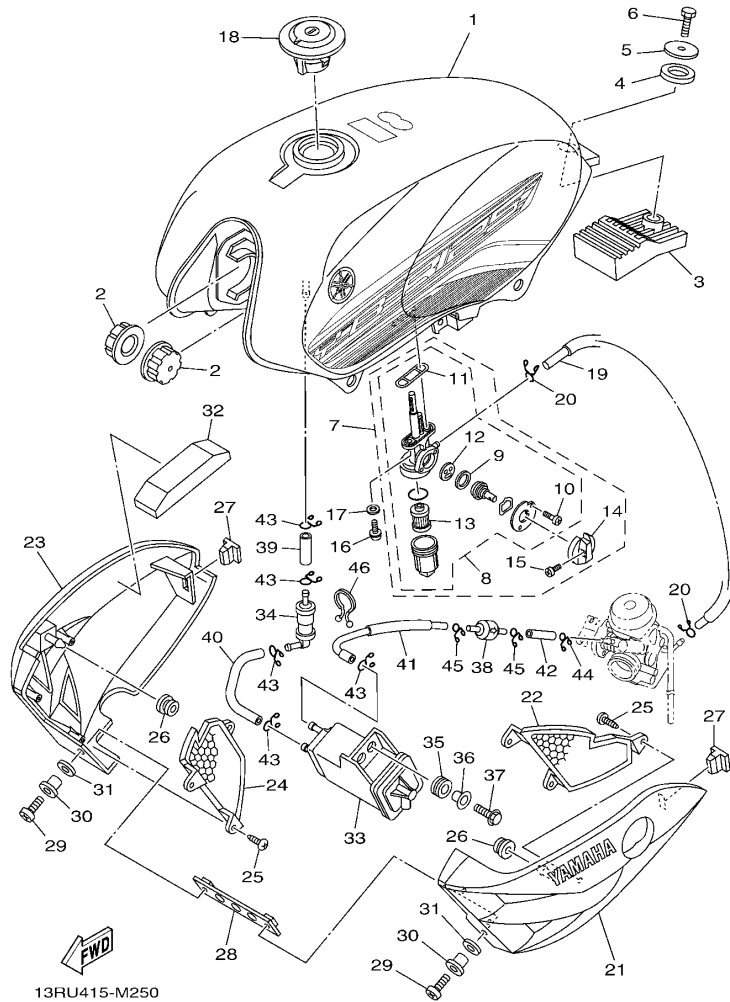

13RU415-M250

参照 号码	零件号码 PART NO.	零件名称 DESCRIPTION	13RU	13RV	13RW	13RX	备注 REMARKS
1	13R-W2411-03-P1	油箱组合 FUEL TANK ASSY	1	1	1	1	金属黑色车用 FOR SMX
2	4FP-F4181-00	定位减震器 1 DAMPER, LOCATING 1	2	2	2	2	
3	5VL-F4183-00	定位减震器 3 DAMPER, LOCATING 3	1	1	1	1	
4	5VL-F4182-00	定位减震器 2 DAMPER, LOCATING 2	1	1	1	1	
5	90201-088P2	平垫圈 WASHER, PLATE	1	1	1	1	
6	97002-08016	螺栓 BOLT	1	1	1	1	
7	13R-F4510-00	燃油活栓组合 2 FUEL COCK ASSY 2	1	1	1	1	
8	5VL-F4500-01	燃油开关组合 1 FUEL COCK ASSY 1	1	1	1	1	
9	5VL-F4534-01	油封 SEAL, COCK	1	1	1	1	
10	97880-03008	大柱头螺钉 SCREW, PAN HEAD	2	2	2	2	
11	5VL-F4512-01	密封垫 GASKET	1	1	1	1	
12	5VL-F4523-01	阀 VALVE	1	1	1	1	
13	5VL-F4515-00	滤网 2 NET, FILTER 2	1	1	1	1	
14	5VL-F4524-01	开关 LEVER, COCK	1	1	1	1	
15	90157-03800	大柱头螺钉 SCREW, PAN HEAD	1	1	1	1	
16	90159-06820	带垫螺钉 SCREW, WITH WASHER	2	2	2	2	
17	90430-05800	衬垫 GASKET	2	2	2	2	
18	18C-F4610-02	油箱盖总成 CAP ASSY	1	1	1	1	
19	5VL-F4311-00	燃油管 1 PIPE, FUEL 1	1	1	1	1	
20	90467-09854	卡环 CLIP	2	2	2	2	
21	5VL-W137W-00-P7	导流罩 1 SCOOP, AIR 1	1	1	1	1	暗灰色 金属黑色车用 DBNM8 FOR SMX
22	5VL-F137U-20	通风盖 1 GUIDE, AIR 1	1	1	1	1	
23	5VL-W137X-00-P7	导流罩 2 SCOOP, AIR 2	1	1	1	1	暗灰色 金属黑色车用 DBNM8 FOR SMX
24	5VL-F137V-20	通风盖 2 GUIDE, AIR 2	1	1	1	1	
25	97702-40014	自攻螺钉 SCREW, TAPPING	6	6	6	6	
26	90480-13837	橡胶垫 GROMMET	2	2	2	2	
27	5VL-F1778-00	定位减震器 1 DAMPER, LOCATING 1	2	2	2	2	

FIG. 25 油箱

FUEL TANK

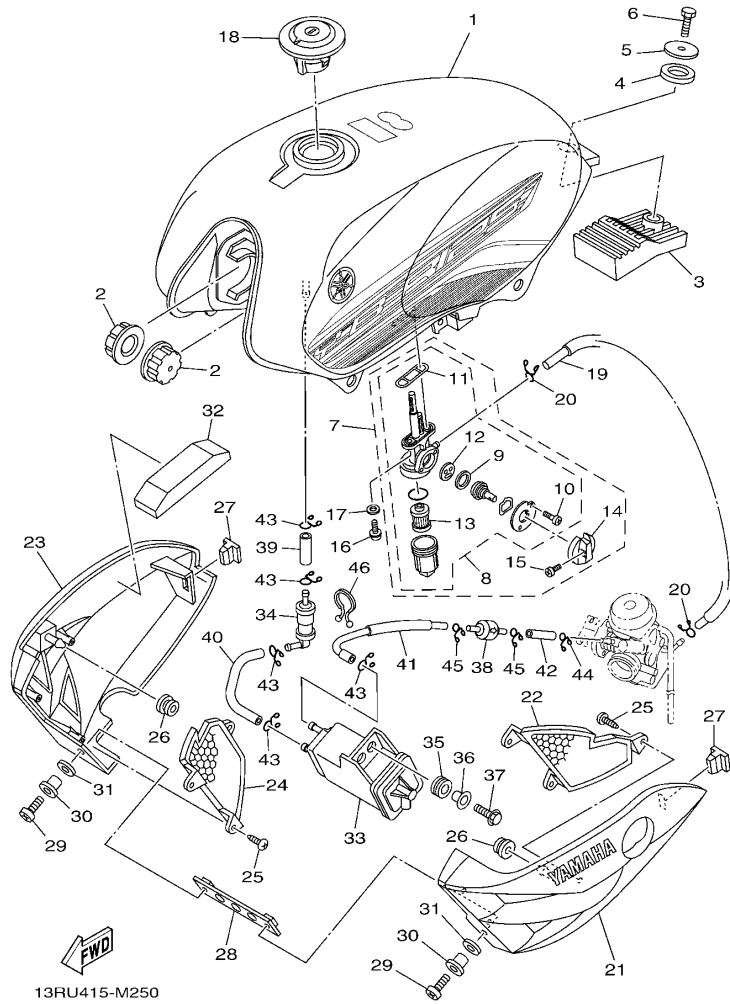

参照 号码	零件号码 PART NO.	零件名称 DESCRIPTION	13RU	13RV	13RW	13RX	备注 REMARKS
28	5VL-F4216-11	支承 STAY	1	1	1	1	
29	98512-06016	十字螺钉 SCREW, PAN HEAD	2	2	2	2	
30	90387-06879	轴套 COLLAR	2	2	2	2	
31	90202-09800	平垫圈 WASHER, PLATE	2	2	2	2	
32	5VL-F414H-00	减震垫 1 DAMPER, PLATE 1	1	1	1	1	
33	13R-F4170-01	过滤缸总成 CANISTER ASSY	1	1	1	1	
34	18C-F4180-01	滚动阀组合 ROLL OVER VALVE ASSY	1	1	1	1	
35	90480-13018	橡胶垫 GROMMET	2	2	2	2	
36	90387-068H9	轴套 COLLAR	2	2	2	2	
37	95022-06016	凸缘螺栓 BOLT, FLANGE	2	2	2	2	
38	1BK-F4682-00	气 VALVE	1	1	1	1	
39	13R-F4312-00	管 2 PIPE 2	1	1	1	1	
40	13R-F4313-00	管 3 PIPE 3	1	1	1	1	
41	1BK-F4314-00	管 4 PIPE 4	1	1	1	1	
42	1BK-F4315-00	管 5 PIPE 5	1	1	1	1	
43	90467-09006	卡环 CLIP	5	5	5	5	
44	90467-07029	卡环 CLIP	1	1	1	1	
45	90467-08806	卡环 CLIP	2	2	2	2	
46	90464-23811	线夹 CLAMP	1	1	1	1	

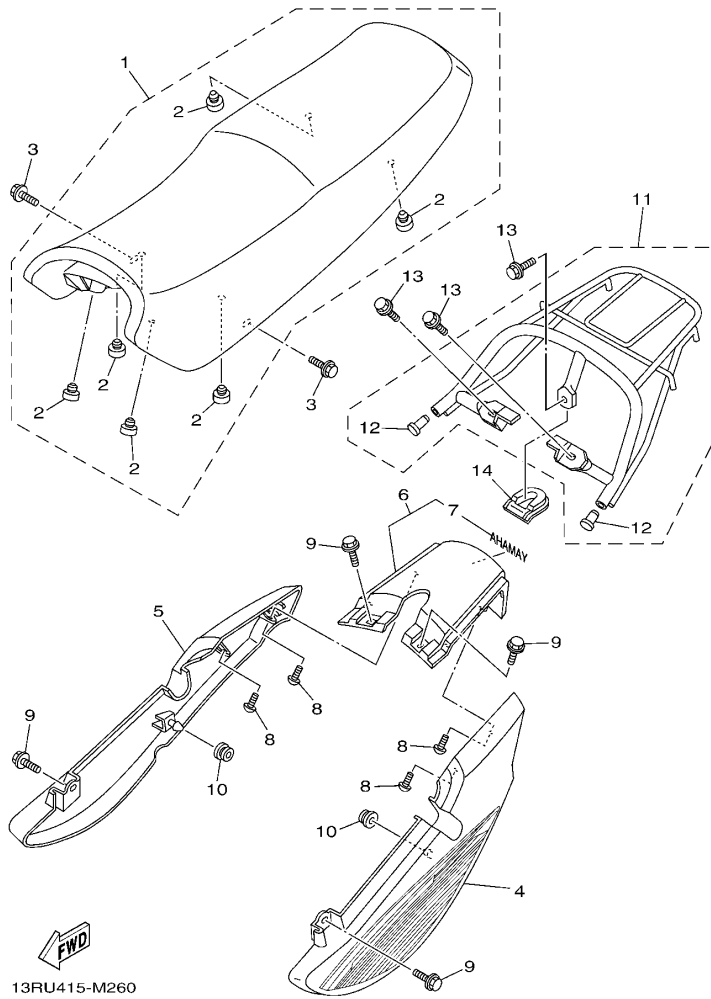

FIG. 26 座位

SEAT

参照 号码	零件号码 PART NO.	零件名称 DESCRIPTION	13RU	13RV	13RW	13RX	备注 REMARKS
1	5VL-F4730-12	双人座垫组合 DOUBLE SEAT ASSY	1	1	1	1	
2	4TU-F4741-00	.缓冲座 .PAD, SEAT	6	6	6	6	
3	90119-06869	带垫螺栓 BOLT, WITH WASHER	2	2	2	2	
4	5VL-W471K-07-P3	尾罩总成 1 TAIL COVER ASSY 1	1	1	1	1	金属黑色车用 FOR SMX
5	5VL-W472K-07-P3	尾罩总成 2 TAIL COVER ASSY 2	1	1	1	1	金属黑色车用 FOR SMX
6	5VL-W4756-00-P3	尾罩总成 TAIL COVER ASSY	1	1	1	1	金属黑色车用 FOR SMX
7	99236-00080	.雅马哈标牌 .EMBLEM, YAMAHA	1	1	1	1	
8	97702-50012	自攻螺钉 SCREW, TAPPING	4	4	4	4	
9	90119-06869	带垫螺栓 BOLT, WITH WASHER	4	4	4	4	
10	90480-01868	橡胶垫 GROMMET	2	2	2	2	
11	2B9-Y2477-00	后货架组合 HANDLE, SEAT	1	1	1	1	
12	5VL-F4481-00	.塞 .PLUG	2	2	2	2	
13	95812-08016	凸缘螺栓 BOLT, FLANGE	3	3	3	3	
14	5VL-F4796-01	盖 COVER	1	1	1	1	

FIG. 27 前轮

FRONT WHEEL

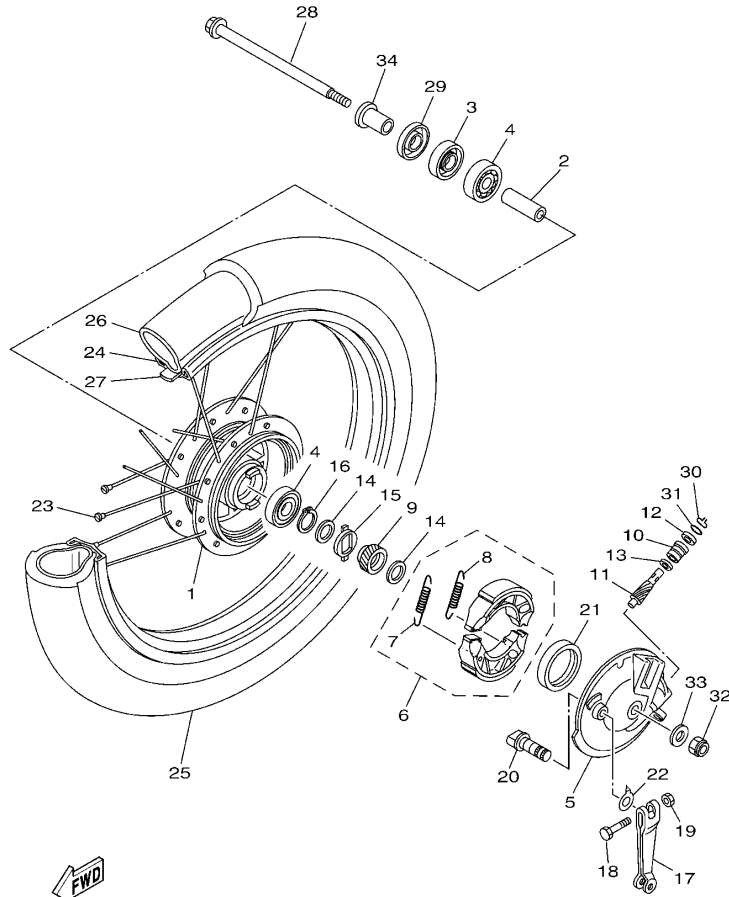

2D0D210-D251

参照 号码	零件号码 PART NO.	零件名称 DESCRIPTION	13RU	13RV	13RW	13FX	备注 REMARKS
1	5VL-F5111-00-35	前轮毂 HUB, FRONT	1				银色 金属黑色车用 SL FOR SMX
2	90560-12828	衬套 SPACER	1				
3	93102-18804	油封 OIL SEAL	1				
4	93306-301Y6	轴承 BEARING	2				
5	5VL-F5121-01-35	前制动盖 PLATE, BRAKE SHOE	1				银色 金属黑色车用 SL FOR SMX
6	5VL-W2533-21	制动蹄块总成 BRAKE SHOE SET	1				
7	90506-12801	拉簧 .SPRING, TENSION	1				
8	90506-15802	拉簧 .SPRING, TENSION	1				
9	1KL-F5135-00	主驱动齿轮 GEAR, DRIVE	1				
10	1KL-F5136-00	衬套 BUSH	1				
11	1KL-F5138-00	仪表齿轮 GEAR, METER	1				
12	93104-07811	油封 OIL SEAL	1				
13	90201-07836	平垫圈 WASHER, PLATE	1				
14	90201-20844	平垫圈 WASHER, PLATE	2				
15	1KL-F5149-01	速度表转动卡环 CLUTCH, METER	1				
16	93410-19831	卡环 CIRCLIP	1				
17	4FP-F5155-11	制动臂 1 LEVER, CAMSHAFT 1	1				
18	90101-06848	螺栓 BOLT	1				
19	95302-06600	螺母 NUT	1				
20	4GU-F5351-02	凸轮轴 CAMSHAFT	1				
21	93105-47802	油封 OIL SEAL	1				
22	4GU-F533A-01	指示片 PLATE, INDICATOR	1				
23	5VL-W5304-01	辐条套件 SPOKE SET, REAR	1				
24	94416-18803	轮辋 (1.60-18) RIM (1.60-18)	1				
25	94127-18823	轮胎 (2.75-18) TIRE (2.75-18 S901 42P 4PR)	1				CHENG SHIN
26	94227-18808	内胎 (2.75-18) TUBE (2.75-18 TR4)	1				CHENG SHIN
27	94327-18800	轮辋箍带 (2.75-18) BAND, RIM (2.75-18)	1				CHENG SHIN

FIG. 27 前轮

FRONT WHEEL

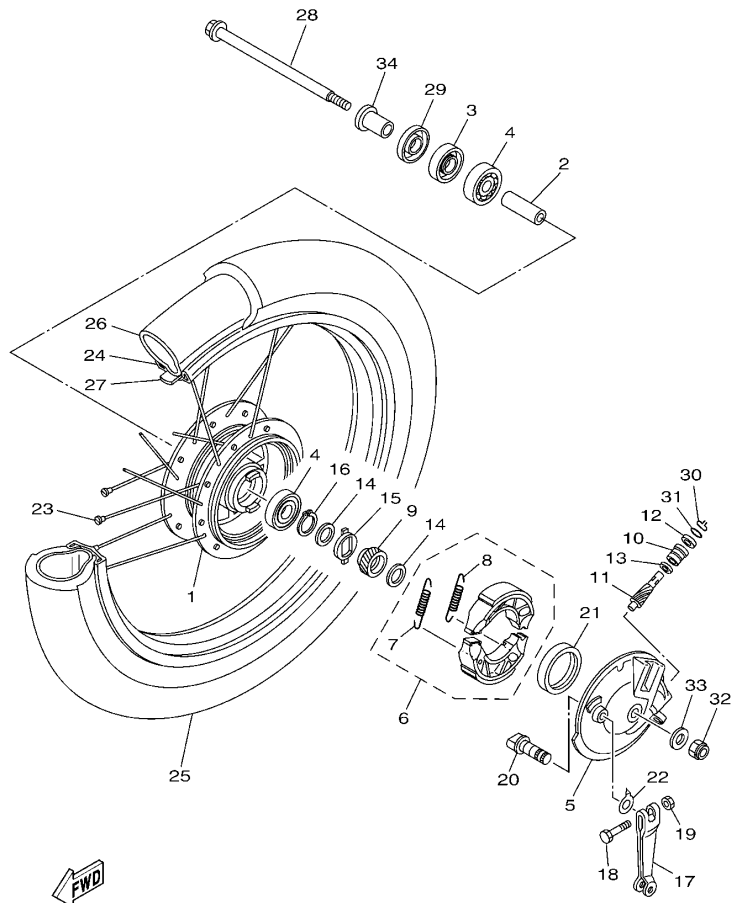

2D0D210-D251

参照 号码	零件号码 PART NO.	零件名称 DESCRIPTION	13RU	13RV	13RW	13FX	备注 REMARKS
28	5VL-F5181-01	前轮轮轴 AXLE, WHEEL	1				
29	1KL-F5118-00	轮毂防尘盖 COVER, HUB DUST	1				
30	1KL-F5137-01	止动环 RING, STOP	1				
31	93210-14818	O型环 O-RING	1				
32	90185-10807	自锁螺母 NUT, SELF-LOCKING	1				
33	90201-108C7	平垫圈 WASHER, PLATE	1				
34	90387-12840	轴套 COLLAR	1				

FIG. 28 前轮 2

FRONT WHEEL 2

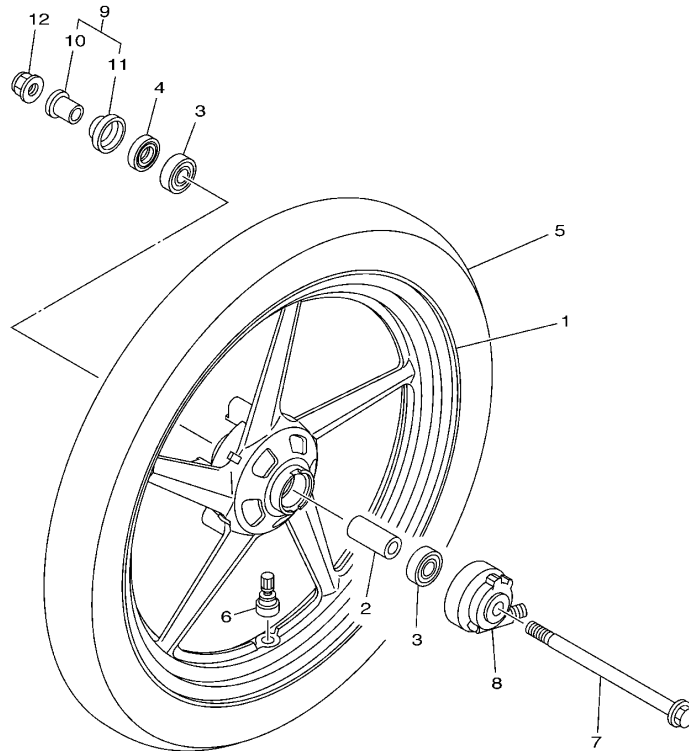

参照 号码	零件号码 PART NO.	零件名称 DESCRIPTION	13RU	13RV	13RW	13RX	备注 REMARKS
1	3D9-F5168-00-8L	前压铸轮 CAST WHEEL, FRONT		1		1	金色 金属黑色车用 NG FOR SMX
2	90560-15293	衬套 SPACER		1		1	
3	93306-202Y4	轴承 BEARING			2	2	
4	93102-20857	油封 OIL SEAL		1		1	
5	94127-18828	轮胎 (2.75-18) TIRE (2.75-18 C901 4PR 42P TL)		1		1	轮胎 CHENG SHIN
6	93900-00826	气门嘴 VALVE, RIM		1		1	
7	5VL-F5181-11	前轮轮轴 AXLE, WHEEL		1		1	
8	4GU-F5190-12	齿轮装置组合 GEAR UNIT ASSY		1		1	
9	4GU-F511X-01	轴套组 COLLAR		1		1	
10	90387-158K1	轴套 COLLAR		1		1	
11	4GU-F5118-00	轮毂防尘盖 COVER, HUB DUST		1		1	
12	95602-14200	自锁螺母 NUT, SELF-LOCKING		1		1	



43B1200-G250

FIG. 29 前轮 3

FRONT WHEEL 3

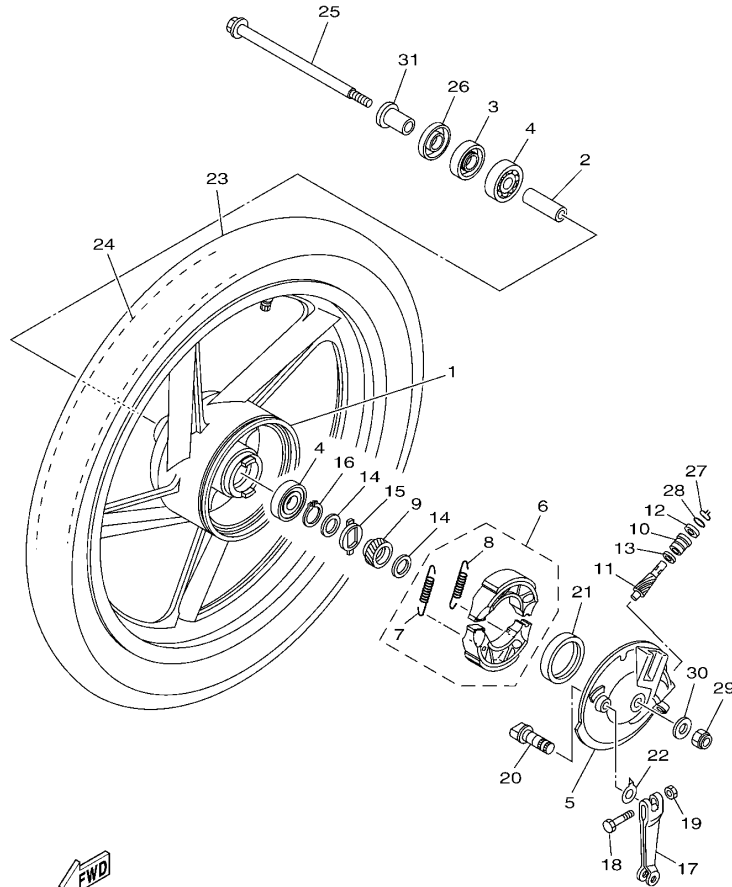

1BK1415-J250

参照 号码	零件号码 PART NO.	零件名称 DESCRIPTION	13RU	13RV	13RW	13RX	备注 REMARKS
1	1BK-F5168-00-8L	前压铸轮 CAST WHEEL, FRONT				1	金色 金属黑色车用 NG FOR SMX
2	90560-12828	衬套 SPACER				1	
3	93102-18806	油封 OIL SEAL				1	
4	93306-301XS	轴承 BEARING				2	
5	5VL-F5121-01-8L	前制动盖 PLATE, BRAKE SHOE				1	金色 金属黑色车用 NG FOR SMX
6	5VL-W2533-21	制动蹄块总成 BRAKE SHOE SET				1	
7	90506-12801	.拉簧 .SPRING, TENSION				1	
8	90506-15802	.拉簧 .SPRING, TENSION				1	
9	1KL-F5135-00	主驱动齿轮 GEAR, DRIVE				1	
10	1KL-F5136-00	衬套 BUSH				1	
11	1KL-F5138-00	仪表齿轮 GEAR, METER				1	
12	93104-07811	油封 OIL SEAL				1	
13	90201-07836	平垫圈 WASHER, PLATE				1	
14	90201-20844	平垫圈 WASHER, PLATE				2	
15	1KL-F5149-01	速度表转动卡环 CLUTCH, METER				1	
16	93410-19831	卡环 CIRCLIP				1	
17	4FP-F5155-11	制动臂 1 LEVER, CAMSHAFT 1				1	
18	90101-06848	螺栓 BOLT				1	
19	95302-06600	螺母 NUT				1	
20	4GU-F5351-02	凸轮轴 CAMSHAFT				1	
21	93105-47802	油封 OIL SEAL				1	
22	4GU-F533A-01	指示片 PLATE, INDICATOR				1	
23	94127-18823	轮胎 (2.75-18) TIRE (2.75-18 S901 42P 4PR)				1	CHENG SHIN
24	94227-18808	内胎 (2.75-18) TUBE (2.75-18 TR4)				1	CHENG SHIN
25	5VL-F5181-01	前轮轮轴 AXLE, WHEEL				1	
26	1KL-F5118-00	轮毂防尘盖 COVER, HUB DUST				1	
27	1KL-F5137-01	止动环 RING, STOP				1	

FIG. 29 前轮 3

FRONT WHEEL 3

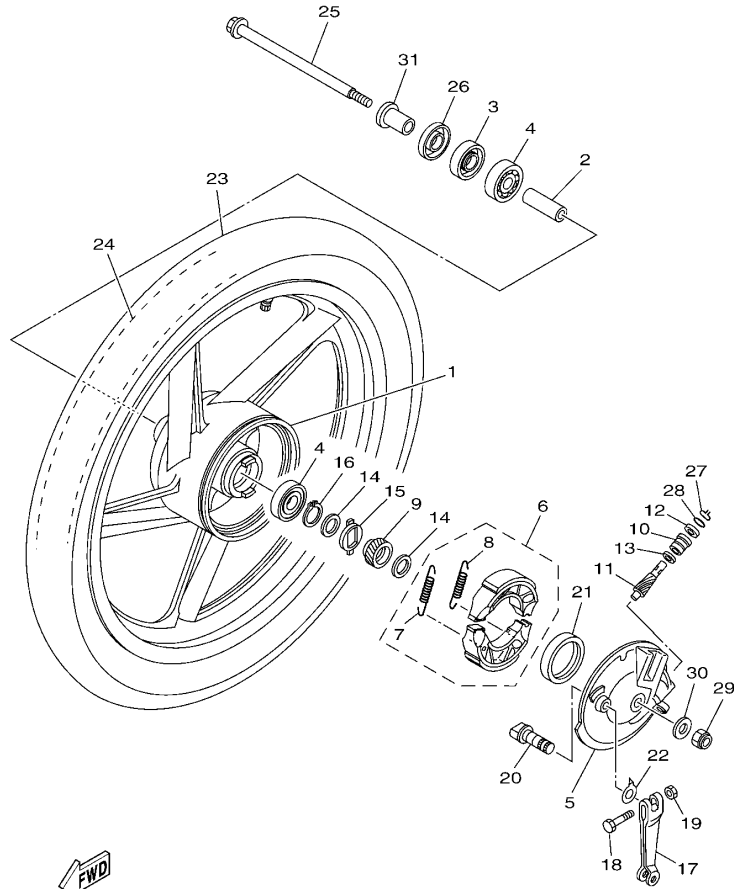

参照 号码	零件号码 PART NO.	零件名称 DESCRIPTION	13RU	13RV	13RW	13RX	备注 REMARKS
28	93210-14818	O 型环 O-RING			1		
29	90185-10807	自锁螺母 NUT, SELF-LOCKING			1		
30	90201-108C7	平垫圈 WASHER, PLATE			1		
31	90387-12840	轴套 COLLAR			1		



1BK1415-J250

FIG. 30 前制动器卡钳

FRONT BRAKE CALIPER

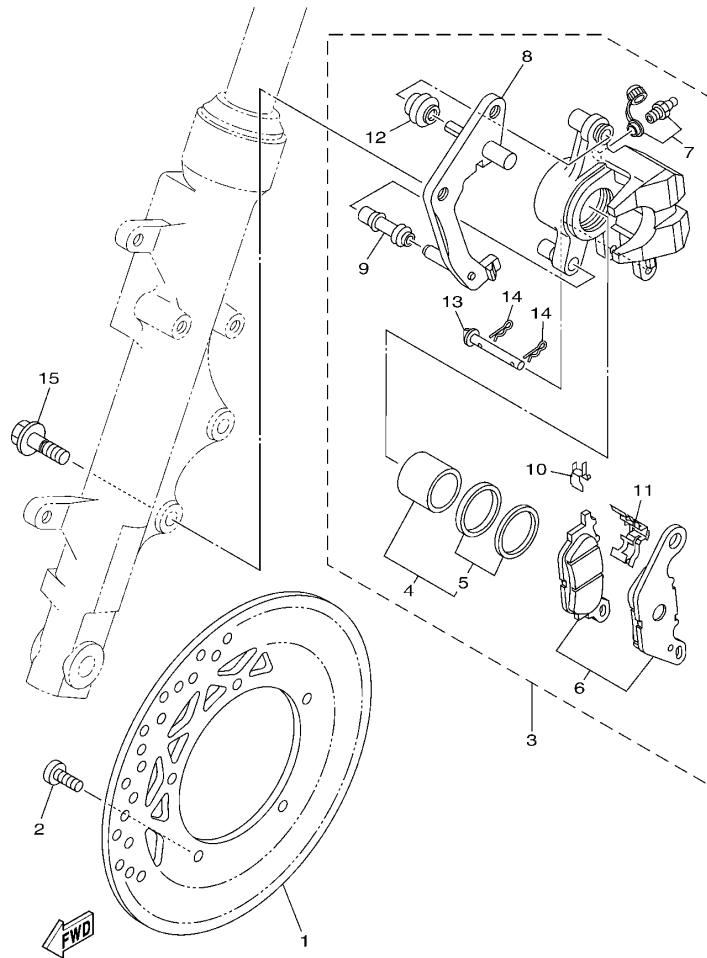

13R6415-H270

参照 号码	零件号码 PART NO.	零件名称 DESCRIPTION	13RU	13RV	13RW	13RX	备注 REMARKS
1	3D9-F582U-00	制动盘 (右边) DISK, BRAKE (RIGHT)		1		1	
2	90111-08805	六角螺栓 BOLT, HEX. SOCKET BUTTON		5		5	
3	3D9-F580U-01	制动器卡钳组合 (右边) CALIPER ASSY (RIGHT)		1		1	
4	4S5-W0057-00	. 卡钳活塞组合 . PISTON ASSY, CALIPER		1		1	
5	4S5-W0047-00	. 卡钳密封套件 . CALIPER SEAL KIT		1		1	
6	4S5-W0045-00	. 刹车片组合 . BRAKE PAD KIT		1		1	
7	4S5-W0048-01	. 带孔螺钉套件 . BLEED SCREW KIT		1		1	
8	4S5-F5921-01	. 支承托架 . BRACKET, SUPPORT		1		1	
9	4S5-F5937-00	. 保护罩 2 . BOOT 2		1		1	
10	4S5-F5939-00	. 扣片 . CLIP, PAD		1		1	
11	4S5-F5919-00	. 衬垫支承 . SUPPORT, PAD		1		1	
12	4S5-F5917-00	. 卡钳套 . BOOT, CALIPER		1		1	
13	4S5-F5924-01	. 刹车片销 . PIN, PAD		1		1	
14	4S5-F5925-00	. 卡环 . CLIP		2		2	
15	90105-10831	凸缘螺栓 BOLT, FLANGE		2		2	

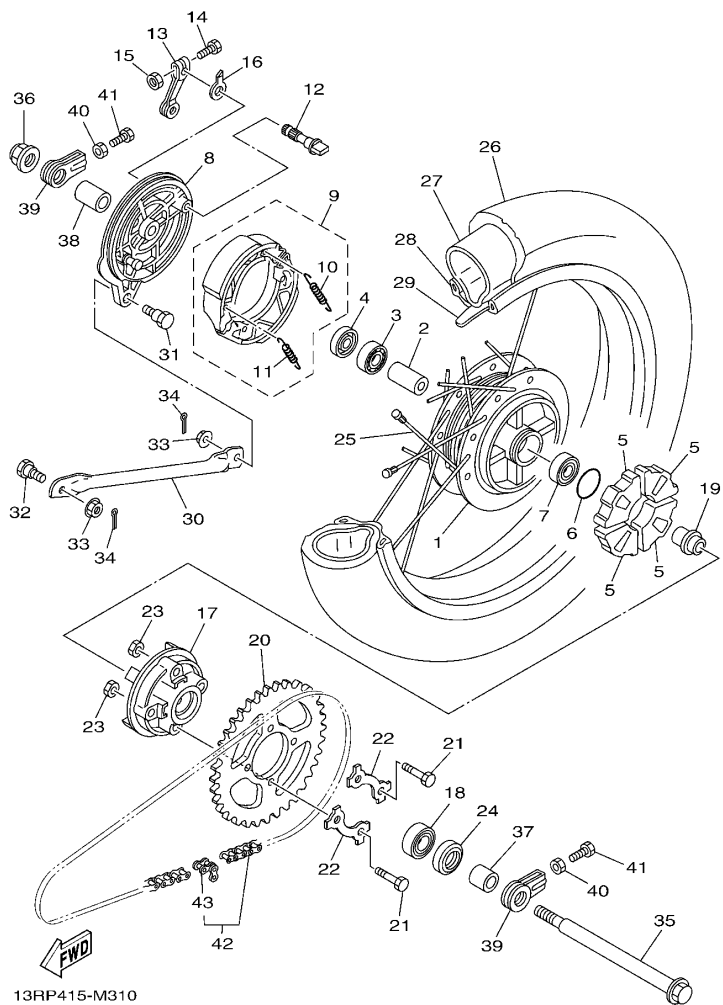

13RP415-M310

FIG. 31 后轮

REAR WHEEL

参照 号码	零件号码 PART NO.	零件名称 DESCRIPTION	13RU	13RV	13RW	13FX	备注 REMARKS
1	5VL-F5311-00-35	后轮毂 HUB, REAR	1				银色 金属黑色车用 SL FOR SMX
2	90387-15809	轴套 COLLAR	1				
3	93306-252YY	轴承 BEARING	1				
4	93104-22803	油封 OIL SEAL	1				
5	1KL-F5364-00	减震垫 DAMPER	4				
6	93210-42803	O型环 O-RING	1				银色 金属黑色车用 SL FOR SMX
7	93306-252XA	轴承 BEARING	1				
8	5VL-F5321-01-35	后制动盖 PLATE, BRAKE SHOE	1				
9	5VL-W2533-21	制动蹄块总成 BRAKE SHOE SET	1				
10	90506-12801	.拉簧 .SPRING, TENSION	1				
11	90506-15802	.拉簧 .SPRING, TENSION	1				
12	4GU-F5351-02	凸轮轴 CAMSHAFT	1				
13	5VL-F5355-01	制动臂 1 LEVER, CAMSHAFT	1				
14	90101-06848	螺栓 BOLT	1				
15	95302-06600	螺母 NUT	1				
16	4GU-F533A-01	指示片 PLATE, INDICATOR	1				
17	5VL-F5366-00	轮毂离合器 CLUTCH, HUB	1				
18	93306-054X3	轴承 BEARING	1				
19	5VL-F5387-01	链轮轴轴 AXLE, SPROCKET	1				
20	5VL-F5445-01	大链轮 SPROCKET, DRIVEN (45T)	1				
21	90109-08864	螺栓 BOLT	4				
22	5LK-F5412-01	垫片 WASHER	2				
23	90179-08639	螺母 NUT	4				
24	93106-26804	油封 OIL SEAL	1				
25	5VL-W5304-01	辐条套件 SPOKE SET, REAR	1				
26	94109-18805	轮胎 TIRE (90/90-18 S180 57P)	1				CHENG SHIN
27	94227-18808	内胎 (2.75-18) TUBE (2.75-18 TR4)	1				CHENG SHIN

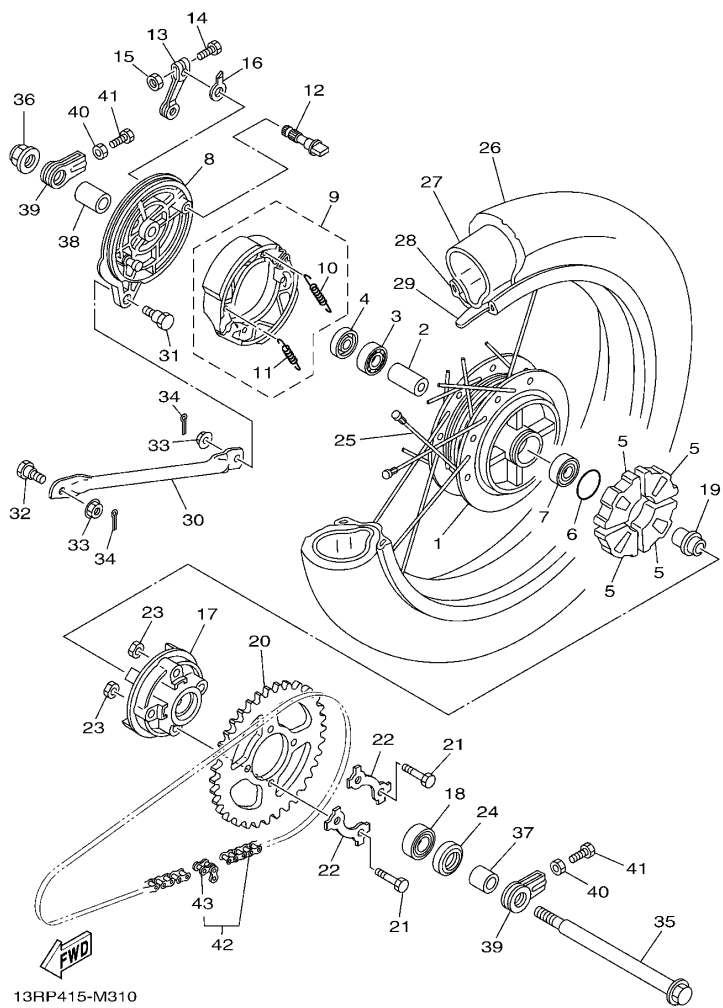

13RP415-M310

FIG. 31 后轮

REAR WHEEL

参照 号码	零件号码 PART NO.	零件名称 DESCRIPTION	13RU	13RV	13RW	13FX	备注 REMARKS
28	94418-18802	轮辋 (1.85-18) RIM (1.85-18)	1				CHENG SHIN
29	94327-18800	轮辋箍带 (2.75-18) BAND, RIM (2.75-18)	1				
30	5VL-F5371-00	拉杆 BAR, TENSION	1				
31	90109-08847	螺栓 BOLT	1				
32	90109-08848	螺栓 BOLT	1				
33	95702-08500	螺母 NUT, FLANGE	2				
34	91402-20012	开口销 PIN, COTTER	2				
35	5VL-F5381-01	后轮轮轴 AXLE, WHEEL	1				
36	95602-14200	自锁螺母 NUT, SELF-LOCKING	1				
37	5VL-F5386-01	链轮轴安装套 COLLAR, SPROCKET AXLE	1				
38	5VL-F5377-01	轴套 COLLAR, WHEEL	1				
39	5VL-F5388-01	链条张紧板 1 PULLER, CHAIN 1	2				
40	95312-08600	螺母 NUT	2				
41	90153-08804	六角头螺钉 SCREW, HEXAGON	2				
42	5VL-F53C0-10	链条总成 CHAIN (DID428H 118L)	1				
43	94668-E2001	链条接头 JOINT, CHAIN (DID 428H)	1				

FIG. 32 后轮 2

REAR WHEEL 2

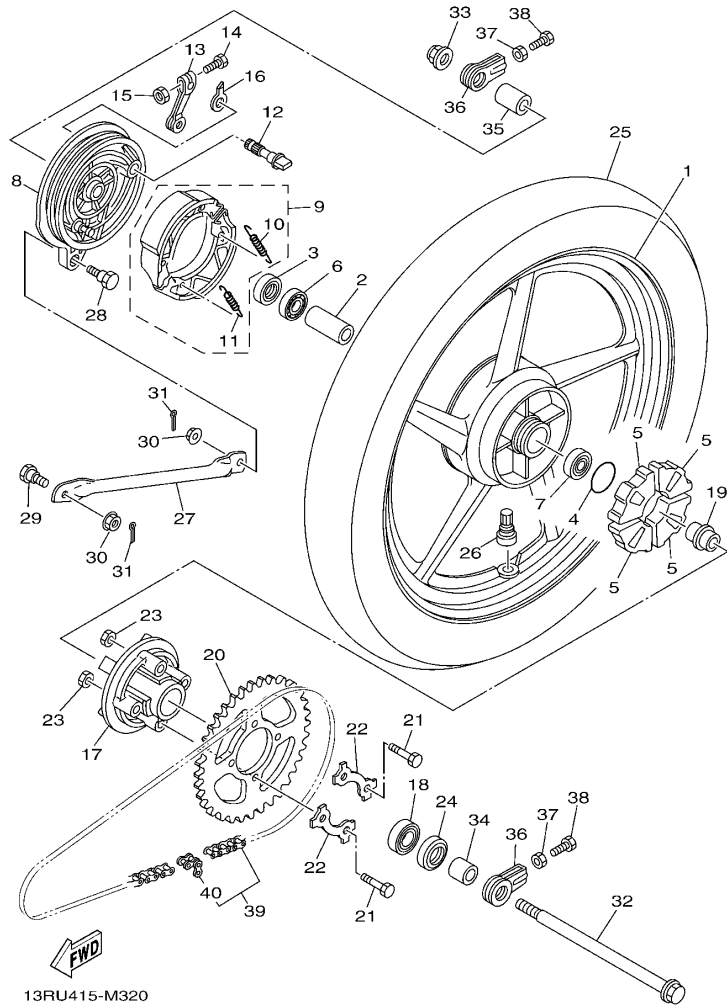

13RU415-M320

参照 号码	零件号码 PART NO.	零件名称 DESCRIPTION	13RU	13RV	13RW	13RX	备注 REMARKS
1	3D9-F5338-00-8L	后压铸轮 CAST WHEEL, REAR		1		1	金色 金属黑色车用 NG FOR SMX
2	90387-15809	轴套 COLLAR		1		1	
3	93104-22802	油封 OIL SEAL		1		1	
4	93210-42807	O型环 O-RING		1		1	
5	1KL-F5364-00	减震垫 DAMPER		4		4	
6	93306-252YY	轴承 BEARING		1		1	
7	93306-252XA	轴承 BEARING		1		1	
8	5VL-F5321-01-8L	后制动盖 PLATE, BRAKE SHOE		1		1	金色 金属黑色车用 NG FOR SMX
9	5VL-W2533-21	制动蹄块总成 BRAKE SHOE SET		1		1	
10	90506-12801	.拉簧 .SPRING, TENSION		1		1	
11	90506-15802	.拉簧 .SPRING, TENSION		1		1	
12	4GU-F5351-02	凸轮轴 CAMSHAFT		1		1	
13	5VL-F5355-01	制动臂 1 LEVER, CAMSHAFT		1		1	
14	90101-06848	螺栓 BOLT		1		1	
15	95302-06600	螺母 NUT		1		1	
16	4GU-F533A-01	指示片 PLATE, INDICATOR		1		1	
17	5VL-F5366-00	轮毂离合器 CLUTCH, HUB		1		1	
18	93306-054X3	轴承 BEARING		1		1	
19	5VL-F5387-01	链轮轮轴 AXLE, SPROCKET		1		1	
20	5VL-F5445-01	大链轮 SPROCKET, DRIVEN (45T)		1		1	
21	90109-08864	螺栓 BOLT		4		4	
22	5LK-F5412-01	垫片 WASHER		2		2	
23	90179-08639	螺母 NUT		4		4	
24	93106-26804	油封 OIL SEAL		1		1	
25	94109-18807	轮胎 TIRE (90/90-18 C905 57P TL)		1		1	轮胎 CHENG SHIN
26	93900-00826	气门嘴 VALVE, RIM		1		1	
27	5VL-F5371-00	拉杆 BAR, TENSION		1		1	

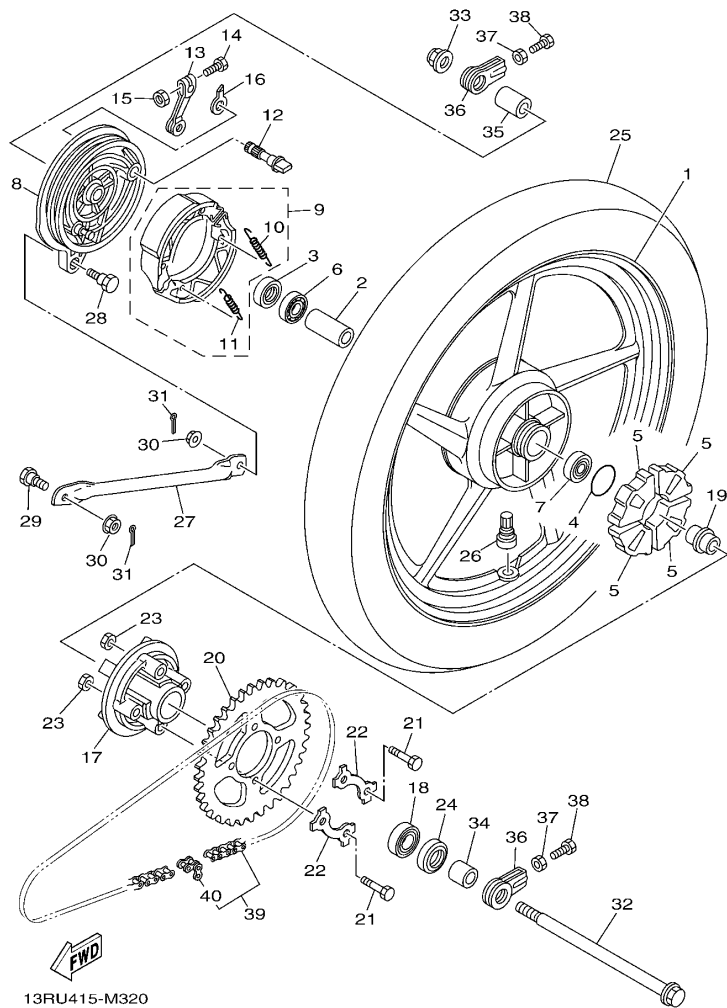

FIG. 32 后轮 2

REAR WHEEL 2

参照 号码	零件号码 PART NO.	零件名称 DESCRIPTION	13RU	13RV	13RW	13RX	备注 REMARKS
28	90109-08847	螺栓 BOLT		1		1	
29	90109-08848	螺栓 BOLT		1		1	
30	95702-08500	螺母 NUT, FLANGE		2		2	
31	91402-20012	开口销 PIN, COTTER		2		2	
32	5VL-F5381-01	后轮轮轴 AXLE, WHEEL		1		1	
33	95602-14200	自锁螺母 NUT, SELF-LOCKING		1		1	
34	5VL-F5386-01	链轮轴安装套 COLLAR, SPROCKET AXLE		1		1	
35	5VL-F5377-01	轴套 COLLAR, WHEEL		1		1	
36	5VL-F5388-01	链条张紧板 1 PULLER, CHAIN 1		2		2	
37	95312-08600	螺母 NUT		2		2	
38	90153-08804	六角头螺钉 SCREW, HEXAGON		2		2	
39	5VL-F53C0-10	链条总成 CHAIN (DID428H 118L)		1		1	
40	94668-E2001	链条接头 .JOINT, CHAIN (DID 428H)		1		1	

FIG. 33 后轮 3

REAR WHEEL 3

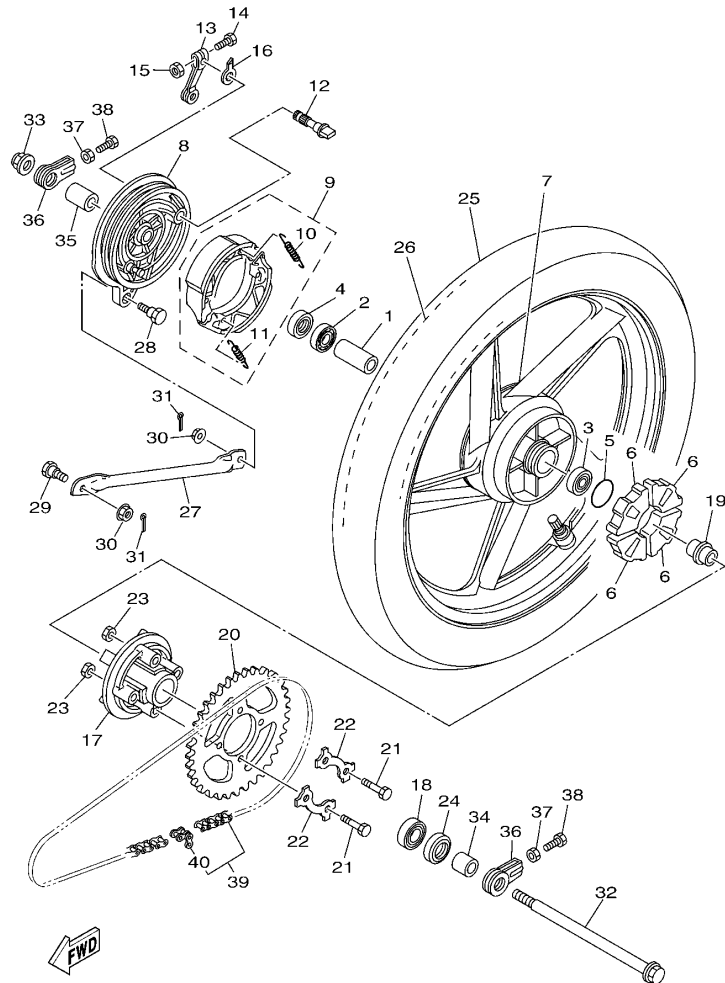

13RU415-M330

参照 号码	零件号码 PART NO.	零件名称 DESCRIPTION	13RU	13RV	13RW	13RX	备注 REMARKS
1	90387-15809	轴套 COLLAR				1	
2	93306-252YY	轴承 BEARING				1	
3	93306-252XA	轴承 BEARING				1	
4	93104-22803	油封 OIL SEAL				1	
5	93210-42803	O型环 O-RING				1	
6	1KL-F5364-00	减震垫 DAMPER				4	
7	1BK-F5338-00-8L	后压铸轮 CAST WHEEL, REAR				1	金色 金属黑色车用 NG FOR SMX
8	5VL-F5321-01-8L	后制动盖 PLATE, BRAKE SHOE				1	金色 金属黑色车用 NG FOR SMX
9	5VL-W2533-21	制动蹄块总成 BRAKE SHOE SET				1	
10	90506-12801	.拉簧 .SPRING, TENSION				1	
11	90506-15802	.拉簧 .SPRING, TENSION				1	
12	4GU-F5351-02	凸轮轴 CAMSHAFT				1	
13	5VL-F5355-01	制动臂 1 LEVER, CAMSHAFT				1	
14	90101-06848	螺栓 BOLT				1	
15	95302-06600	螺母 NUT				1	
16	4GU-F533A-01	指示片 PLATE, INDICATOR				1	
17	5VL-F5366-00	轮毂离合器 CLUTCH, HUB				1	
18	93306-054X3	轴承 BEARING				1	
19	5VL-F5387-01	链轮轴 AXLE, SPROCKET				1	
20	5VL-F5445-01	大链轮 SPROCKET, DRIVEN (45T)				1	
21	90109-08864	螺栓 BOLT				4	
22	5LK-F5412-01	垫片 WASHER				2	
23	90179-08639	螺母 NUT				4	
24	93106-26804	油封 OIL SEAL				1	
25	94109-18805	轮胎 TIRE (90/90-18 S180 57P)				1	CHENG SHIN
26	94227-18808	内胎 (2.75-18) TUBE (2.75-18 TR4)				1	CHENG SHIN
27	5VL-F5371-00	拉杆 BAR, TENSION				1	

FIG. 33 后轮 3

REAR WHEEL 3

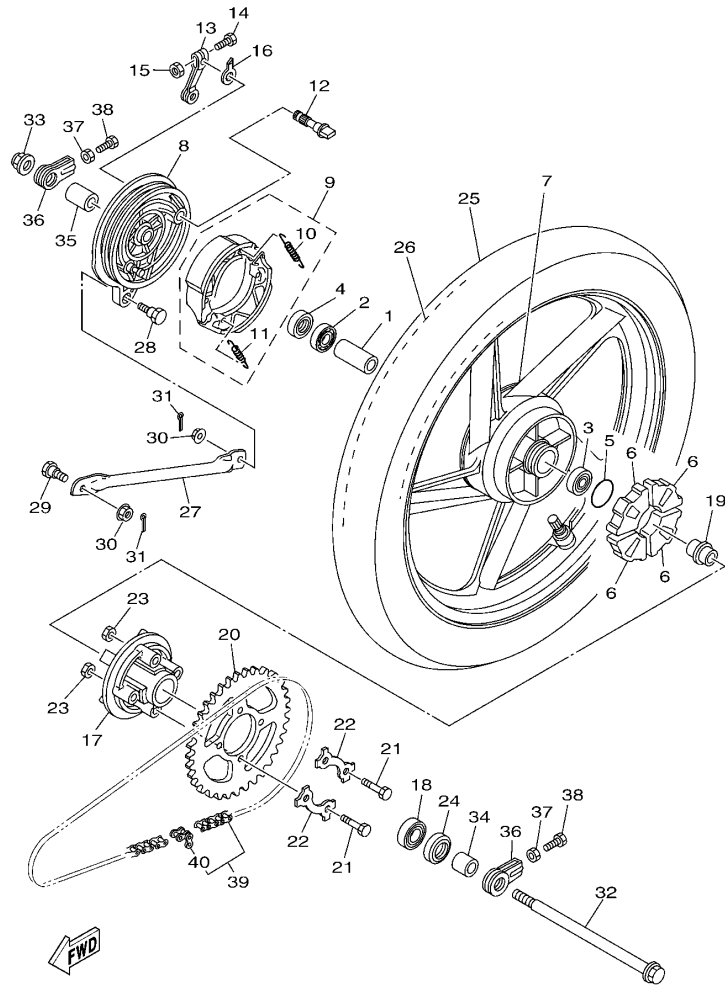

13RU415-M330

参照 号码	零件号码 PART NO.	零件名称 DESCRIPTION	13RU	13RV	13RW	13RX	备注 REMARKS
28	90109-08847	螺栓 BOLT				1	
29	90109-08848	螺栓 BOLT				1	
30	95702-08500	螺母 NUT, FLANGE				2	
31	91402-20012	开口销 PIN, COTTER				2	
32	5VL-F5381-01	后轮轴轴 AXLE, WHEEL				1	
33	95602-14200	自锁螺母 NUT, SELF-LOCKING				1	
34	5VL-F5386-01	链轮轴安装套 COLLAR, SPROCKET AXLE				1	
35	5VL-F5377-01	轴套 COLLAR, WHEEL				1	
36	5VL-F5388-01	链条张紧板 1 PULLER, CHAIN 1				2	
37	95312-08600	螺母 NUT				2	
38	90153-08804	六角头螺钉 SCREW, HEXAGON				2	
39	5VL-F53C0-10	链条总成 CHAIN (DID428H 118L)				1	
40	94668-E2001	链条接头 .JOINT, CHAIN (DID 428H)				1	

FIG. 34 操纵手柄 钢索(鼓刹)

STEERING CABLE FOR DRUM BRAKE

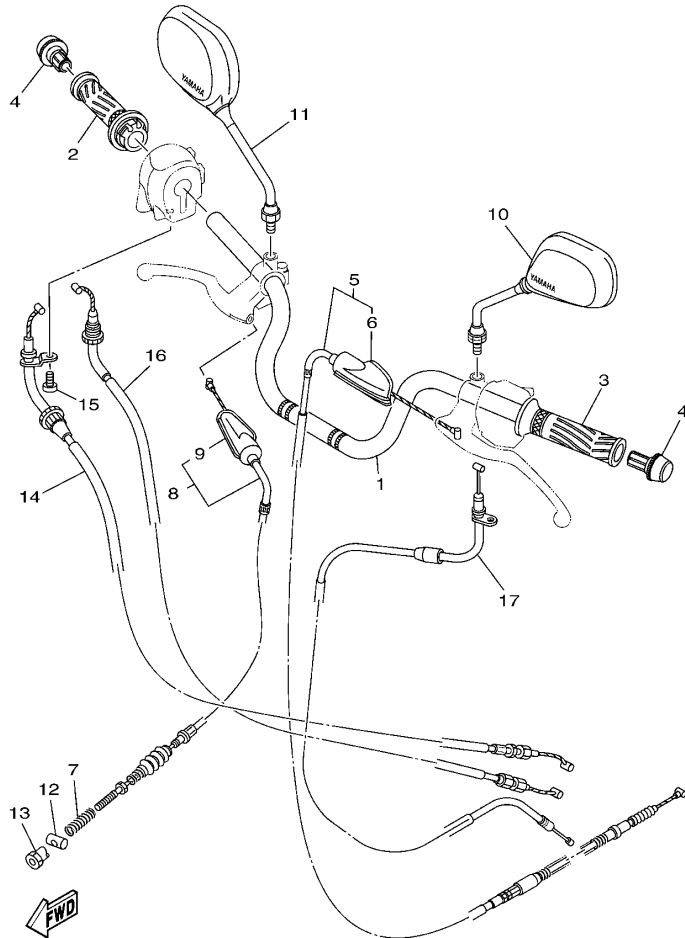

13RF415-L340

参照 号码	零件号码 PART NO.	零件名称 DESCRIPTION	13RU	13RV	13RW	13RX	备注 REMARKS
1	13R-F6111-00	手把 HANDLEBAR	1		1		
2	18C-F6240-00	握把(右边) GRIP ASSY	1		1		
3	5VL-F6241-10	握把(左边) GRIP	1		1		
4	5VL-F628J-10	握把盖 CAP, GRIP	2		2		
5	5VL-F6335-11	离合器拉索 CABLE, CLUTCH	1		1		
6	5VL-F6372-01	.手柄套 1 .COVER, HANDLE LEVER 1	1		1		
7	90501-08803	压簧 SPRING, COMPRESSION	1		1		
8	5VL-F6341-11	制动拉索 1 WIRE, BRAKE 1	1		1		
9	5VL-F6372-01	.手柄套 1 .COVER, HANDLE LEVER 1	1		1		
10	13R-F6280-00	后视镜组合(左边) REAR VIEW MIRROR ASSY (LEFT)	1		1		
11	13R-F6290-00	后视镜组合(右边) REAR VIEW MIRROR ASSY (RIGHT)	1		1		
12	90249-12808	销 PIN	1		1		
13	90179-06826	螺母 NUT	1		1		
14	2D0-F6311-01	节气门拉索 1 CABLE, THROTTLE 1	1		1		
15	98502-05010	十字螺钉 SCREW, PAN HEAD	1		1		
16	2D0-F6312-01	节气门拉索 2 CABLE, THROTTLE 2	1		1		
17	1SF-F6331-00	起动机钢索 CABLE, STARTER 1	1		1		

FIG. 35 操纵手柄 钢索(碟刹)

STEERING CABLE FOR DISK BRAKE

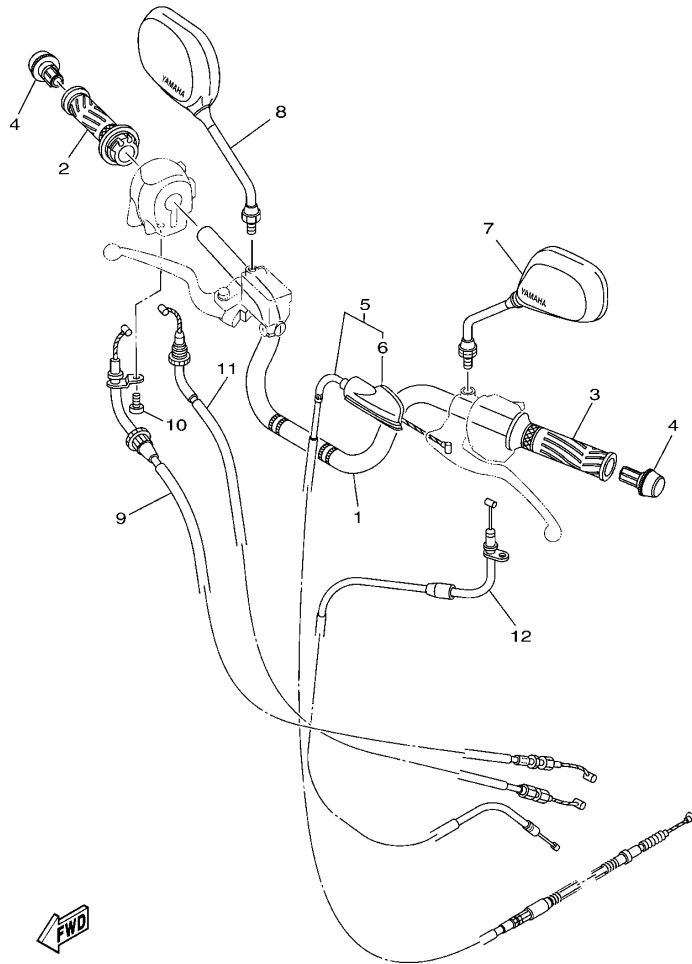

 13RF415-L350

参照 号码	零件号码 PART NO.	零件名称 DESCRIPTION	13RU	13RV	13RW	13RX	备注 REMARKS
1	13R-F6111-00	手把 HANDLEBAR		1		1	
2	18C-F6240-00	握把(右边) GRIP ASSY		1		1	
3	5VL-F6241-10	握把(左边) GRIP		1		1	
4	5VL-F628J-10	握把盖 CAP, GRIP		2		2	
5	5VL-F6335-11	离合器拉索 CABLE, CLUTCH		1		1	
6	5VL-F6372-01	手柄套 1 .COVER, HANDLE LEVER 1		1		1	
7	13R-F6280-00	后视镜组合(左边) REAR VIEW MIRROR ASSY (LEFT)		1		1	
8	13R-F6290-00	后视镜组合(右边) REAR VIEW MIRROR ASSY (RIGHT)		1		1	
9	46S-F6311-00	节气门拉索 1 CABLE, THROTTLE 1		1			
	2D0-F6311-01	节气门拉索 1 CABLE, THROTTLE 1				1	
10	98502-05010	十字螺钉 SCREW, PAN HEAD		1		1	
11	46S-F6312-00	节气门拉索 2 CABLE, THROTTLE 2		1			
	2D0-F6312-01	节气门拉索 2 CABLE, THROTTLE 2				1	
12	13R-F6331-00	起动机钢索 CABLE, STARTER 1		1			
	1SF-F6331-00	起动机钢索 CABLE, STARTER 1				1	

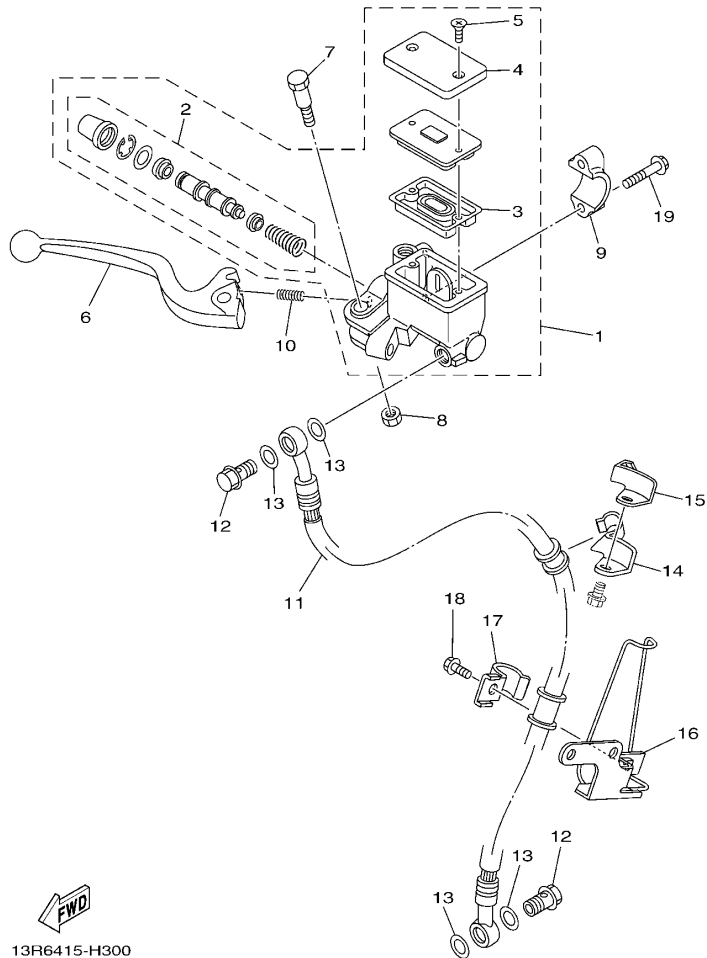

13R6415-H300

FIG. 36 前主缸

FRONT MASTER CYLINDER

参照 号码	零件号码 PART NO.	零件名称 DESCRIPTION	13RU	13RV	13RW	13RX	备注 REMARKS
1	2B9-W583T-02	前主缸组合 MASTER CYLINDER ASSY		1		1	
2	3D9-W0041-02	.前主缸套件 .CYLINDER KIT, MASTER		1		1	
3	4KL-F5854-00	.油箱隔膜 .DIAPHRAGM, RESERVOIR		1		1	
4	4KL-F5852-00	.储油箱盖 .CAP, RESERVOIR		1		1	
5	4KL-F589H-01	.螺钉 .SCREW		2		2	
6	5VL-H3922-21	手柄 2 LEVER 2		1		1	
7	3D9-F589F-01	手柄螺栓 BOLT, LEVER		1		1	
8	3D9-F586F-01	手柄螺帽 NUT, U		1		1	
9	5VL-F5867-00	主缸托架 BRACKET, MASTER CYLINDER		1		1	
10	3D9-F5865-01	手柄弹簧 SPRING, LEVER		1		1	
11	5VL-F5872-11	制动软管 1 HOSE, BRAKE 1		1		1	
12	90401-10811	螺栓 BOLT, UNION		2		2	
13	90201-108J9	平垫圈 WASHER, PLATE		4		4	
14	5VL-F5887-00	制动软管支架 HOLDER, BRAKE HOSE		1		1	
15	5VL-F5886-00	制动软管支架 HOLDER, BRAKE HOSE		1		1	
16	5VL-F5875-01	制动软管支架 1 HOLDER, BRAKE HOSE 1		1		1	
17	5VL-F5876-00	制动软管支架 2 HOLDER, BRAKE HOSE 2		1		1	
18	95022-06016	凸缘螺栓 BOLT, FLANGE		1		1	
19	95022-06025	凸缘螺栓 BOLT, FLANGE		2		2	

FIG. 37 搁脚·支架

STAND & FOOTREST

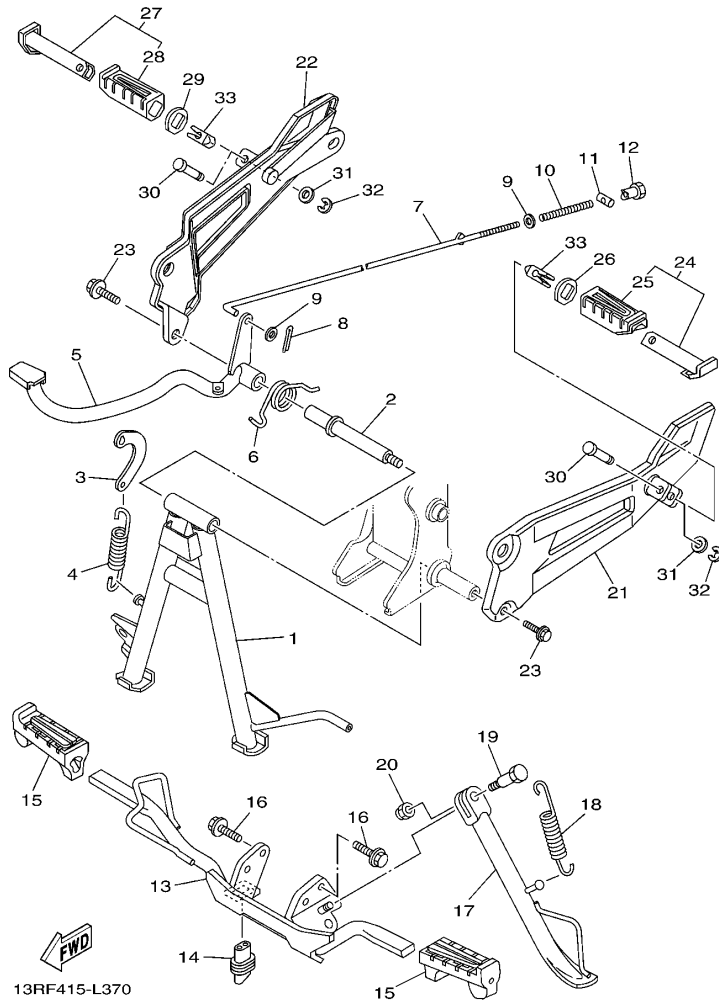

参照 号码	零件号码 PART NO.	零件名称 DESCRIPTION	13RU	13RV	13RW	13RX	备注 REMARKS
1	1BK-F7111-00	主支承 STAND, MAIN	1	1	1	1	
2	5VL-F7112-11	主支承轴 SHAFT, MAIN STAND	1	1	1	1	
3	5VL-F7115-01	连接板 LINK, MAIN STAND	1	1	1	1	
4	90506-32800	拉簧 SPRING, TENSION	1	1	1	1	
5	1SF-F7211-00	制动踏板 PEDAL, BRAKE	1	1	1	1	
6	90508-40801	扭簧 SPRING, TORSION	1	1	1	1	
7	5VL-F7231-01	制动拉杆 ROD, BRAKE	1	1	1	1	
8	91402-20012	开口销 PIN, COTTER	1	1	1	1	
9	92902-06200	垫圈 WASHER	2	2	2	2	
10	90501-10806	压簧 SPRING, COMPRESSION	1	1	1	1	
11	90249-12808	销 PIN	1	1	1	1	
12	90179-06826	螺母 NUT	1	1	1	1	
13	1SF-F7411-00	搁脚板 1 FOOTREST 1	1	1	1	1	
14	5VL-H2109-00	软管接头 JOINT, HOSE	1	1	1	1	
15	5VL-F7413-00	搁脚套 COVER, FOOTREST	2	2	2	2	
16	95812-08020	凸缘螺栓 BOLT, FLANGE	2	2	2	2	
17	5VL-F7311-00	侧支承 STAND, SIDE	1	1	1	1	
18	90506-29800	拉簧 SPRING, TENSION	1	1	1	1	
19	90109-10849	螺栓 BOLT	1	1	1	1	
20	90185-10807	自锁螺母 NUT, SELF-LOCKING	1	1	1	1	
21	5VL-F7452-00	搁脚板托架 1 BRACKET, FOOTREST 1	1	1	1	1	
22	3D9-F7462-00	搁脚板托架 2 BRACKET, FOOTREST 2	1	1	1	1	
23	95812-08020	凸缘螺栓 BOLT, FLANGE	2	2	2	2	
24	5VL-F7430-01	后搁脚板组合 1 REAR FOOTREST ASSY 1	1	1	1	1	
25	5VL-F7433-00	后搁脚板套 COVER, REAR FOOTREST	1	1	1	1	
26	5VL-F7445-01	面板 1 PLATE 1	1	1	1	1	
27	5VL-F7440-01	后搁脚板组合 2 REAR FOOTREST ASSY 2	1	1	1	1	

FIG. 37 搁脚·支架

STAND & FOOTREST

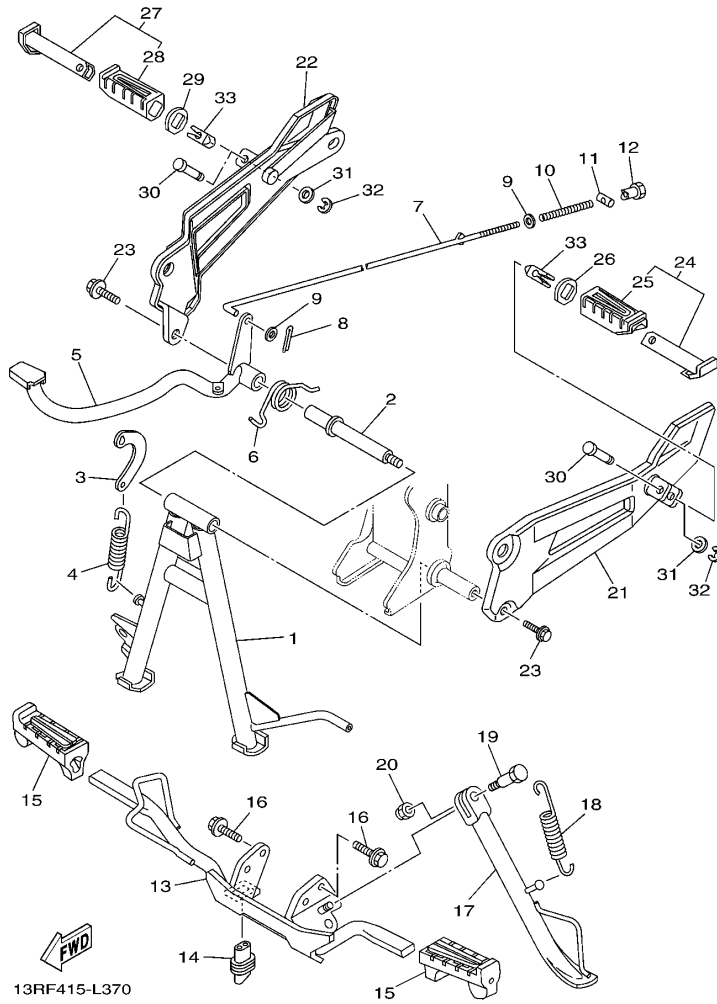

参照 号码	零件号码 PART NO.	零件名称 DESCRIPTION	13RU	13RV	13RW	13RX	备注 REMARKS
28	5VL-F7444-00	后搁脚板套 .COVER, REAR FOOTREST	1	1	1	1	
29	5VL-F7445-01	面板 1 PLATE 1	1	1	1	1	
30	90249-06800	销 PIN	2	2	2	2	
31	92902-06200	垫圈 WASHER	2	2	2	2	
32	99002-05600	卡环 CLIP	2	2	2	2	
33	5VL-F7414-00	搁脚板减震 DAMPER, FOOTREST	2	2	2	2	

FIG. 38 导流罩 1

COWLING 1

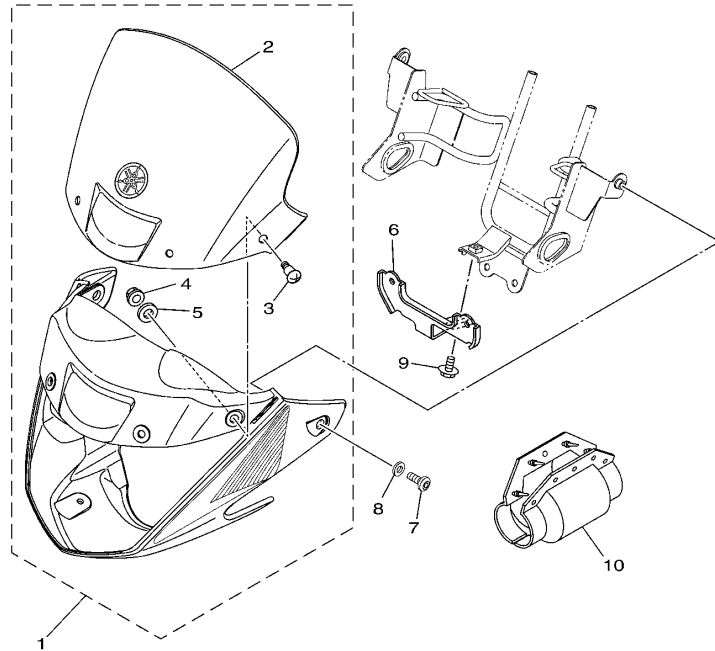

13RK415-L380

参照 号码	零件号码 PART NO.	零件名称 DESCRIPTION	13RU	13RV	13RW	13RX	备注 REMARKS
1	13R-W2835-01-P0	整流罩总成 COWLING ASSY		1			金属黑色车用 FOR SMX
2	13R-W8381-00	.挡风玻璃总成 .WINDSHIELD		1			
3	90149-05800	.螺钉 .SCREW		4			
4	95702-05500	.螺母 .NUT, FLANGE		4			
5	5VL-F8215-01	.专用垫圈 .WASHER, SPECIAL		4			
6	13R-F8336-00	面板 PLATE		1			
7	90149-06833	螺钉 SCREW		2			
8	90202-06803	平垫圈 WASHER, PLATE		2			
9	95802-06012	凸缘螺栓 BOLT, FLANGE		1			
10	3D9-H2599-00	连接器盖 COVER, CONNECTER		1			

FIG. 39 发电机

GENERATOR

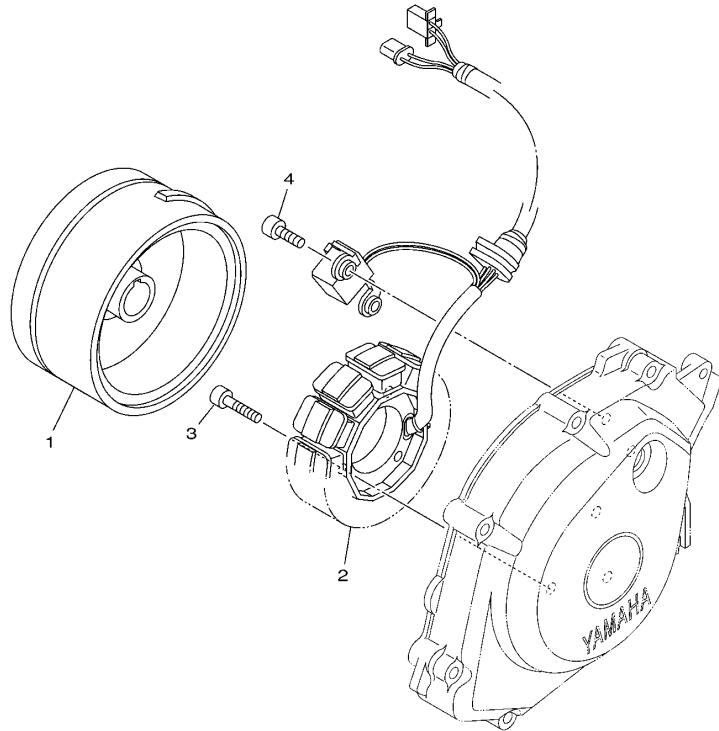

参照 号码	零件号码 PART NO.	零件名称 DESCRIPTION	13RU	13RV	13RW	13RX	备注 REMARKS
1	1BK-H1450-00	转子组合 ROTOR ASSY	1	1	1	1	
2	13R-H1410-00	定子组合 STATOR ASSY	1	1	1	1	
	13R-H1410-10	定子组合 STATOR ASSY	1	1	1	1	加热器车用
3	91312-06025	螺栓 BOLT	3	3	3	3	
	91312-06030	螺栓 BOLT	3	3	3	3	加热器车用
4	91312-06014	螺栓 BOLT	2	2	2	2	

FIG. 40 启动电机

STARTING MOTOR

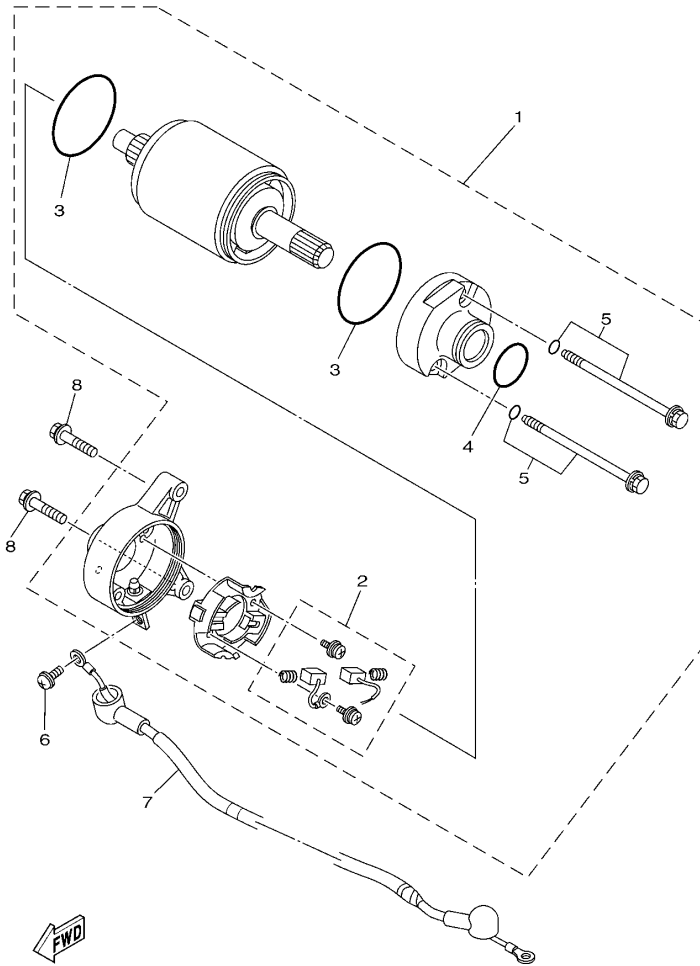

1JP1415-J320

参照 号码	零件号码 PART NO.	零件名称 DESCRIPTION	13RU	13RV	13RW	13RX	备注 REMARKS
1	1JP-H1890-00	启动电机 MOTOR ASSY	1	1	1	1	
2	4FP-H1801-00	.碳刷组件 .BRUSH SET	1	1	1	1	
3	93210-55669	.O型环 .O-RING	2	2	2	2	
4	93210-26668	.O型环 .O-RING	1	1	1	1	
5	4FP-H1828-01	.组合螺钉 .SCREW 2	2	2	2	2	
6	98902-05008	.十字槽盘头螺钉 SCREW, BIND	1	1	1	1	
7	5VL-H183G-01	.导线组件 CORD COMP.	1	1	1	1	
8	95022-06025	.凸缘螺栓 BOLT, FLANGE	2	2	2	2	

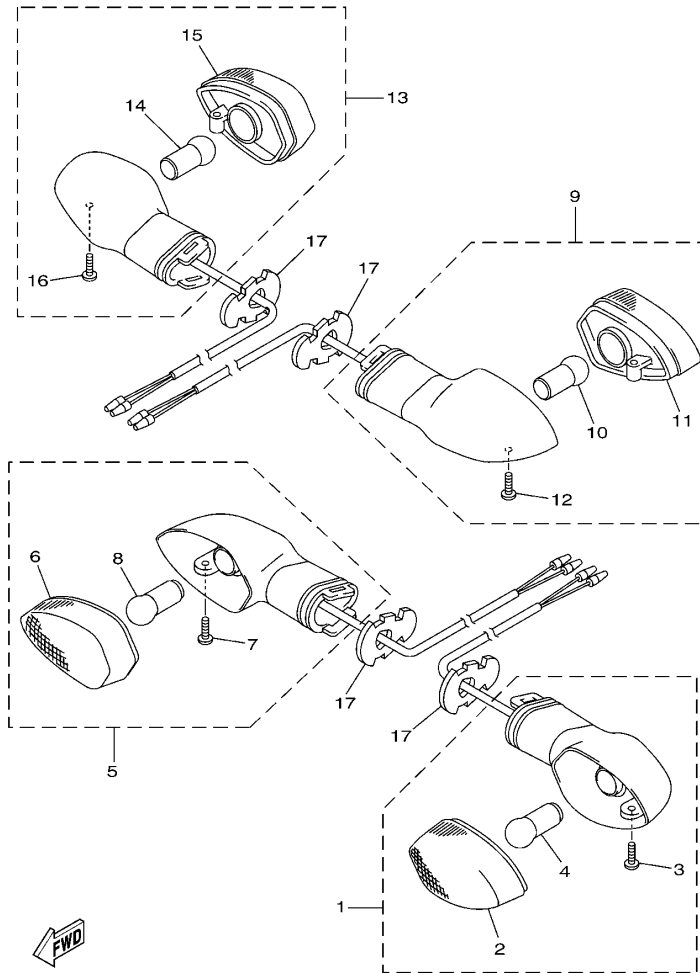

43B1200-G330

FIG. 41 转向灯

FLASHER LIGHT

参照 号码	零件号码 PART NO.	零件名称 DESCRIPTION	13RU	13RV	13RW	13RX	备注 REMARKS
1	5D1-H3310-00	前转向灯组合 1 FRONT FLASHER LIGHT ASSY 1	1	1	1	1	
2	3D9-H333A-00	.透镜组件 1 .LENS COMP 1	1	1	1	1	
3	3D9-H3333-10	.镜面安装螺钉 .SCREW, LENS FITTING	1	1	1	1	
4	3D9-H3311-10	.转向灯灯泡 .BULB, FLASHER (12V-10W)	1	1	1	1	
5	5D1-H3320-00	前转向灯组合 2 FRONT FLASHER LIGHT ASSY 2	1	1	1	1	
6	3D9-H334A-00	.透镜组件 2 .LENS COMP 2	1	1	1	1	
7	3D9-H3333-10	.镜面安装螺钉 .SCREW, LENS FITTING	1	1	1	1	
8	3D9-H3311-10	.转向灯灯泡 .BULB, FLASHER (12V-10W)	1	1	1	1	
9	3D9-H3330-10	后转向灯组合 1 REAR FLASHER LIGHT ASSY 1	1	1	1	1	
10	3D9-H3311-10	.转向灯灯泡 .BULB, FLASHER (12V-10W)	1	1	1	1	
11	3D9-H334A-00	.透镜组件 2 .LENS COMP 2	1	1	1	1	
12	3D9-H3333-10	.镜面安装螺钉 .SCREW, LENS FITTING	1	1	1	1	
13	3D9-H3340-10	后转向灯组合 2 REAR FLASHER LIGHT ASSY 2	1	1	1	1	
14	3D9-H3311-10	.转向灯灯泡 .BULB, FLASHER (12V-10W)	1	1	1	1	
15	3D9-H333A-00	.透镜组件 1 .LENS COMP 1	1	1	1	1	
16	3D9-H3333-10	.镜面安装螺钉 .SCREW, LENS FITTING	1	1	1	1	
17	3D9-H3318-10	转向灯支承 1 STAY, FLASHER 1	4	4	4	4	

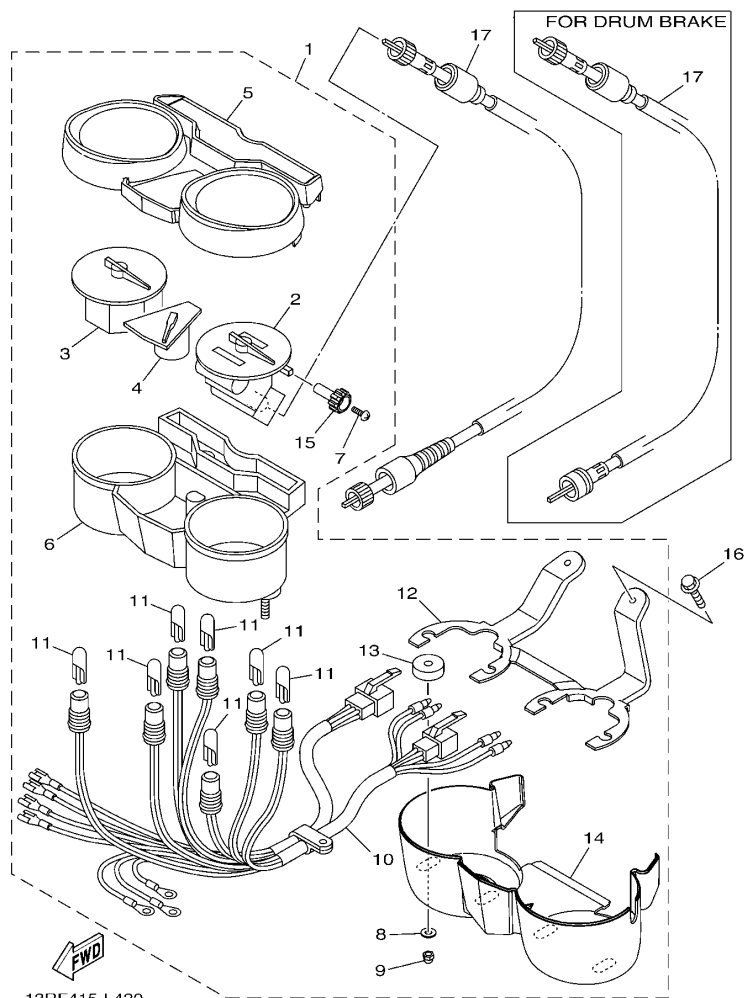

13RF415-L420

FIG. 42 仪表

METER

参照 号码	零件号码 PART NO.	零件名称 DESCRIPTION	13RU	13RV	13RW	13RX	备注 REMARKS
1	13R-H3500-30	仪表组合 METER ASSY	1	1	1	1	
2	13R-HA251-30	.驱动装置 1 .DRIVE UNIT 1	1	1	1	1	
3	13R-HA252-30	.驱动装置 2 .DRIVE UNIT 2	1	1	1	1	
4	13R-HA253-10	.驱动装置 3 .DRIVE UNIT 3	1	1	1	1	
5	13R-H353G-00	.上侧箱 .CASE, UPPER	1	1	1	1	
6	13R-H358L-00	.箱组 .CASE UNIT	1	1	1	1	
7	5VL-H353S-00	.旋钮安装螺钉 .SCREW, KNOB FITTING	1	1	1	1	
8	13R-H3524-00	.专用垫圈 .WASHER, SPECIAL	4	4	4	4	
9	1BK-H354P-00	.螺母 .NUT	4	4	4	4	
10	13R-H3509-00	.导线组合 .SOCKET CORD ASSY	1	1	1	1	
11	4FP-H3517-10	.灯泡 .BULB (12V-1.7W)	7	7	7	7	
12	5VL-H350E-00	.支架 .BRACKET	1	1	1	1	
13	5VL-H3543-00	.减震器托架 .DAMPER, BRACKET	4	4	4	4	
14	18C-H353H-00	.下仪表盖 .CASE, UNDER	1	1	1	1	
15	5VL-H357H-00	.回零旋钮 .KNOB	1	1	1	1	
16	95022-06016	凸缘螺栓 BOLT, FLANGE	2	2	2	2	
	5VL-H3550-23	速度计软轴组合 SPEEDOMETER CABLE ASSY	1		1		
	5VL-H3550-12	速度计软轴组合 SPEEDOMETER CABLE ASSY		1		1	

FIG. 43 前大灯

HEADLIGHT

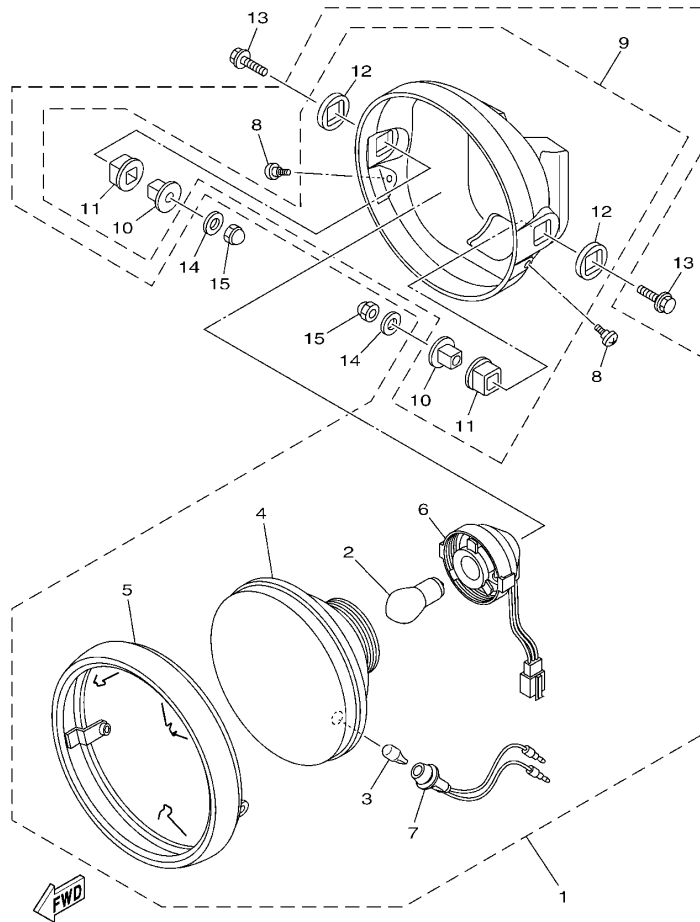

13R6415-H390

参照 号码	零件号码 PART NO.	零件名称 DESCRIPTION	13RU	13RV	13RW	13RX	备注 REMARKS
1	5VL-H4300-23	前照灯组合 HEADLIGHT ASSY	1		1	1	
2	5VL-H4314-20	.前照灯灯泡 .BULB, HEADLIGHT (12V-35/35W)	1		1	1	
3	5VL-H4347-10	.灯泡 .BULB (12V-5W)	1		1	1	
4	5VL-H4310-22	.大灯组件 .HEADLIGHT UNIT ASSY	1		1	1	
5	5VL-H4315-21	.前灯框 .RIM, HEADLIGHT	1		1	1	
6	5VL-H4312-10	.导线组合 .CORD ASSY	1		1	1	
7	5VL-H4159-10	.大灯导线 .CORD, HEADLIGHT	1		1	1	
8	5VL-H4526-00	.螺钉 .SCREW	2		2	2	
9	5VL-H4330-22	.灯体组合 .BODY ASSY	1		1	1	
10	5VL-H4145-00	.套管 .COLLAR, BODY FITTING	2		2	2	
11	5VL-H4163-00	.衬套 .DAMPER	2		2	2	
12	5VL-H4164-00	.衬套 .DAMPER	2		2	2	
13	95023-08030	螺栓 BOLT	2		2	2	
14	90201-08830	平垫圈 WASHER, PLATE	2		2	2	
15	95302-08800	盖形螺母 NUT, CROWN	2		2	2	

FIG. 44 前大灯 2

HEADLIGHT 2

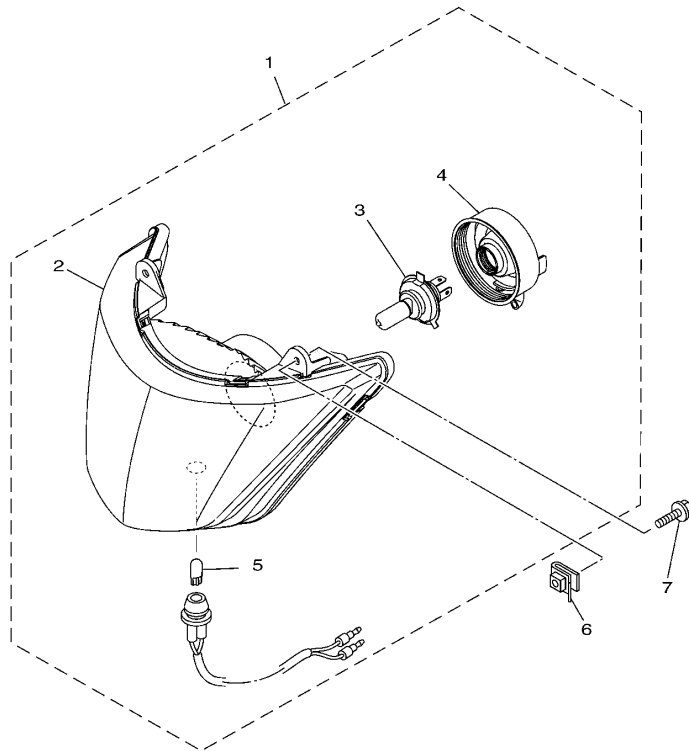

参照 号码	零件号码 PART NO.	零件名称 DESCRIPTION	13RU	13RV	13RW	13RX	备注 REMARKS
1	13R-H4300-00	前照灯组合 HEADLIGHT ASSY		1			
2	13R-H4303-00	. 大灯组件 . HEADLIGHT UNIT ASSY		1			
3	5VL-H4314-60	. 前照灯灯泡 . BULB, HEADLIGHT (12V-35/35W)		1			
4	13R-H4378-00	. 盖 . CAP		1			
5	13R-H4347-00	. 灯泡 . BULB (12V-W5W)		1			
6	90183-050A6	弹性螺母 NUT, SPRING		6			
7	90159-05837	带垫螺钉 SCREW, WITH WASHER		6			

FWD
13RF415-L440

FIG. 45 尾灯

TAILLIGHT

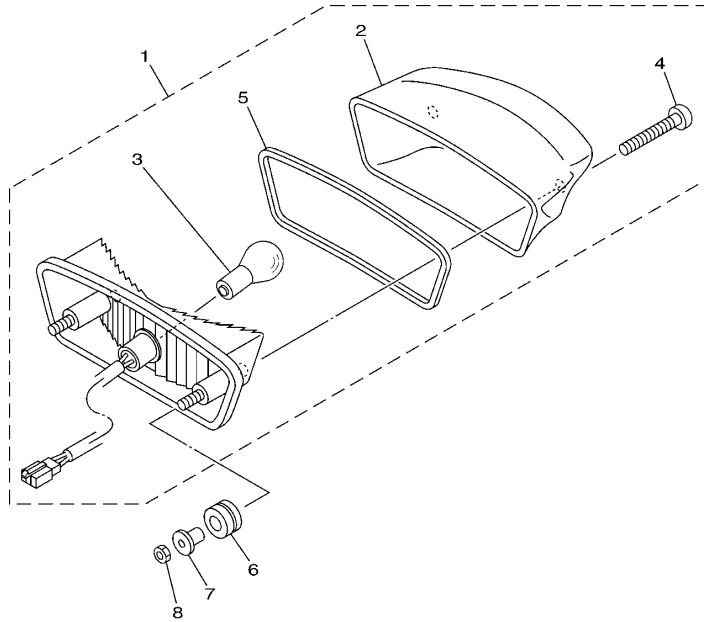



3D92300-F350

参照 号码	零件号码 PART NO.	零件名称 DESCRIPTION	13RU	13RV	13RW	13RX	备注 REMARKS
1	3D9-H4700-00	尾灯组合 TAILLIGHT ASSY	1	1	1	1	
2	3D9-H4721-10	.尾灯透镜 .LENS, TAILLIGHT	1	1	1	1	
3	3D9-H4714-10	.灯泡 .BULB (12V-21/5W)	1	1	1	1	
4	3D9-H4724-10	.镜面安装螺钉 .SCREW, LENS FITTING	2	2	2	2	
5	3D9-H4704-00	.尾灯衬垫 .GASKET, TAILLIGHT	1	1	1	1	
6	90480-14812	橡胶垫 GROMMET	2	2	2	2	
7	90387-06837	轴套 COLLAR	2	2	2	2	
8	95302-06600	螺母 NUT	2	2	2	2	

FIG. 46 手柄开关(鼓刹)

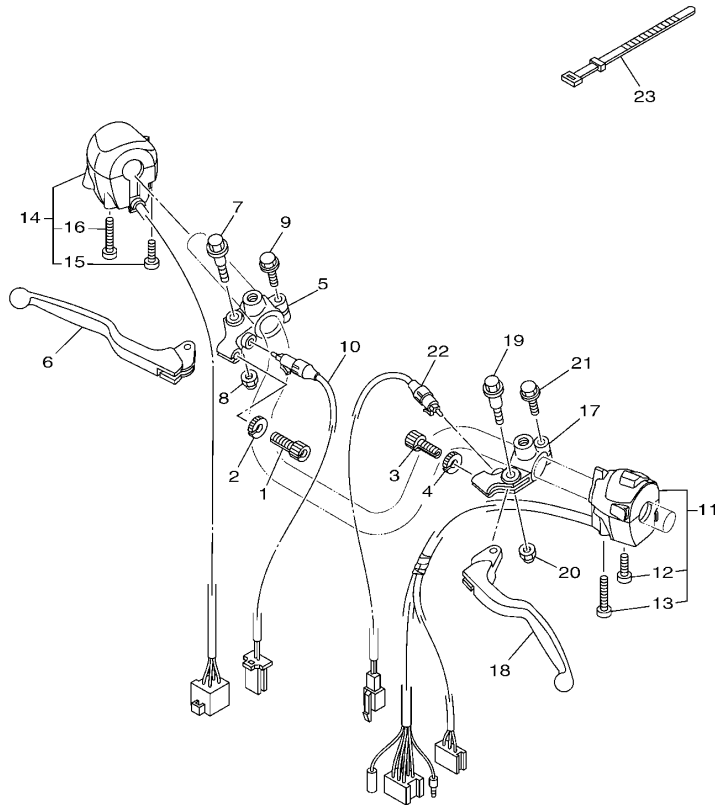
SWITCH & LEVER FOR DRUM BRAKE



13RF415-L461

参照 号码	零件号码 PART NO.	零件名称 DESCRIPTION	13RU	13RV	13RW	13RX	备注 REMARKS
1	90123-08813	螺栓 BOLT	1		1		
2	90179-08862	螺母 NUT	1		1		
3	90123-08813	螺栓 BOLT	1		1		
4	90179-08862	螺母 NUT	1		1		
5	4FP-H2921-00	手柄座 2 HOLDER, LEVER 2	1		1		
6	5VL-H3922-00	手柄 2 LEVER 2	1		1		
7	90109-06850	螺栓 BOLT	1		1		
8	95602-06100	锁紧螺母 NUT, U	1		1		
9	97522-06525	带垫螺栓 BOLT, WITH WASHER	1		1		
10	5VL-H3980-21	前制动开关组合 FRONT STOP SWITCH ASSY	1		1		
11	13R-H3972-00	手把开关 4 SWITCH, HANDLE 4	1		1		
12	98507-05022	.十字螺钉 .SCREW, PAN HEAD	1		1		
13	98507-05042	.十字螺钉 .SCREW, PAN HEAD	1		1		
14	13R-H3975-00	手把开关 2 SWITCH, HANDLE 2	1		1		
15	98507-05025	.十字螺钉 .SCREW, PAN HEAD	1		1		
16	98507-05046	.十字螺钉 .SCREW, PAN HEAD	1		1		
17	4FP-H2911-00	手柄座 1 HOLDER, LEVER 1	1		1		
18	5VL-H3912-00	手柄 1 LEVER 1	1		1		
19	90109-06850	螺栓 BOLT	1		1		
20	95602-06100	锁紧螺母 NUT, U	1		1		
21	97522-06525	带垫螺栓 BOLT, WITH WASHER	1		1		
22	5VL-H2917-11	开关 SWITCH	1		1		
23	4TU-H3936-00	开关导线箍带 BAND, SWITCH CORD	3		3		

FIG. 47 手柄开关(碟刹)

SWITCH & LEVER FOR DISK BRAKE

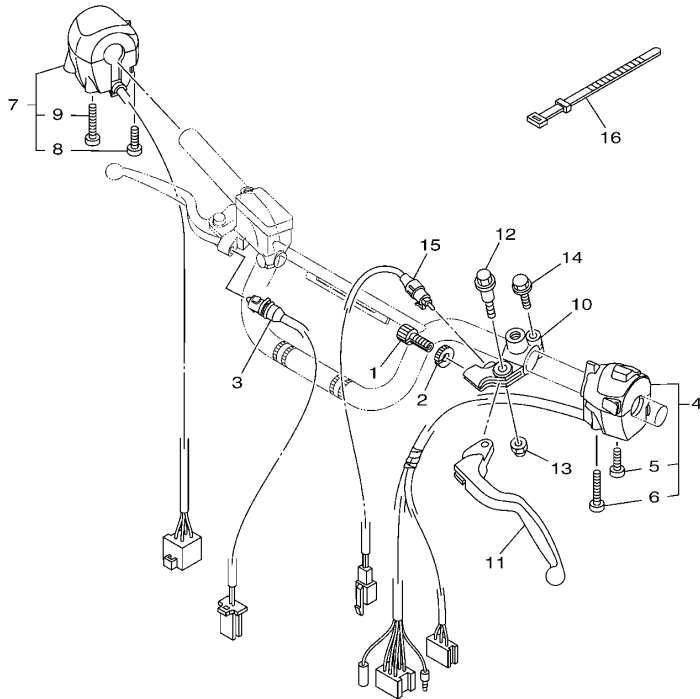

参照 号码	零件号码 PART NO.	零件名称 DESCRIPTION	13RU	13RV	13RW	13RX	备注 REMARKS
1	90123-08813	螺栓 BOLT		1		1	
2	90179-08862	螺母 NUT		1		1	
3	5VL-H3980-01	前制动开关组合 FRONT STOP SWITCH ASSY		1		1	
4	13R-H3972-10 13R-H3972-00	手把开关 4 SWITCH, HANDLE 4 手把开关 4 SWITCH, HANDLE 4		1		1	
5	98507-05022	.十字螺钉 .SCREW, PAN HEAD		1		1	
6	98507-05042	.十字螺钉 .SCREW, PAN HEAD		1		1	
7	13R-H3975-00	手把开关 2 SWITCH, HANDLE 2		1		1	
8	98507-05025	.十字螺钉 .SCREW, PAN HEAD		1		1	
9	98507-05046	.十字螺钉 .SCREW, PAN HEAD		1		1	
10	4FP-H2911-00	手柄座 1 HOLDER, LEVER 1		1		1	
11	5VL-H3912-00	手柄 1 LEVER 1		1		1	
12	90109-06850	螺栓 BOLT		1		1	
13	95602-06100	锁紧螺母 NUT, U		1		1	
14	97522-06525	带垫螺栓 BOLT, WITH WASHER		1		1	
15	5VL-H2917-11	开关 SWITCH		1		1	
16	4TU-H3936-00	开关导线撞带 BAND, SWITCH CORD		3		3	



13RF415-L471

FIG. 48 电气系统 1

ELECTRICAL 1

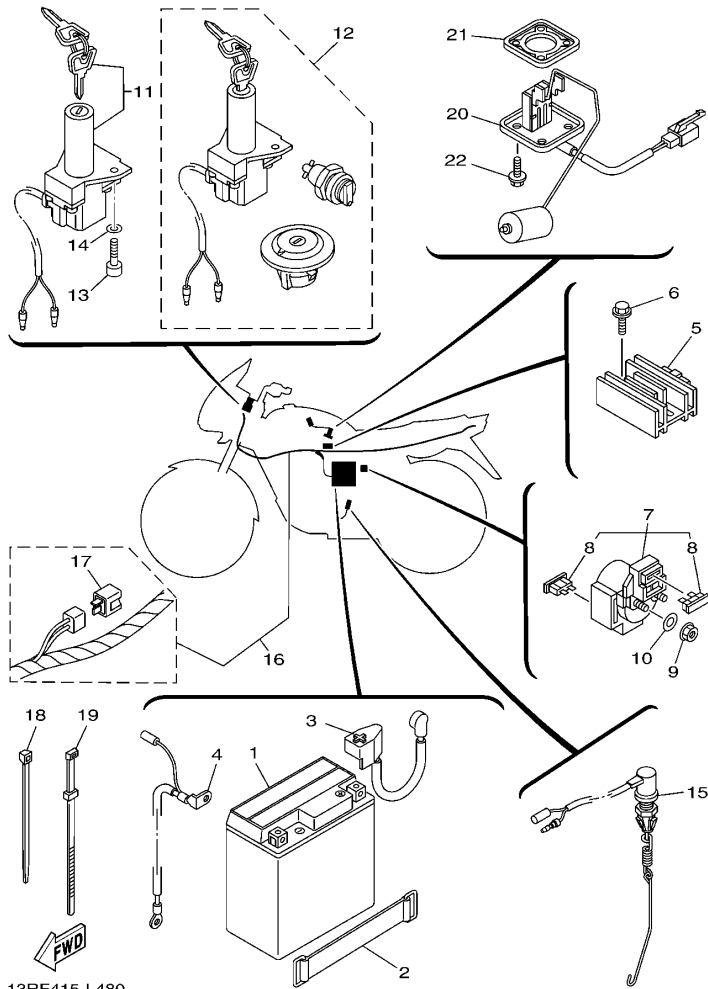

13RF415-L480

参照 号码	零件号码 PART NO.	零件名称 DESCRIPTION	13RU	13RV	13RW	13RX	备注 REMARKS
1	13R-H2100-10	蓄电池组合 BATTERY ASSY (MTX7L-BS)	1	1	1	1	
2	5VL-H2131-01	蓄电池带箍 BAND, BATTERY	1	1	1	1	
3	5VL-H2115-00	正极导线 WIRE, PLUS LEAD	1	1	1	1	
4	5VL-H2116-00	负极导线 WIRE, MINUS LEAD	1	1	1	1	
5	2D0-H1960-10	整流调节器 RECTIFIER & REGULATOR ASSY	1	1	1	1	
6	95802-06020	凸缘螺栓 BOLT, FLANGE	2	2	2	2	
7	5VL-H1940-01	起动继电器组合 STARTER RELAY ASSY	1	1	1	1	
8	4FP-H2151-00	保险丝 FUSE (15A)	2	2	2	2	
9	95302-06600	螺母 NUT	2	2	2	2	
10	90201-068C2	平垫圈 WASHER, PLATE	2	2	2	2	
11	13R-H2501-10	主开关方向锁组合 MAIN SWITCH STEERING LOCK	1	1	1	1	
12	13R-Y8250-03	锁总成 SWITCH ASSY	1	1	1	1	AP AP
13	91312-06020	螺栓 BOLT	2	2	2	2	
14	90201-068C2	平垫圈 WASHER, PLATE	2	2	2	2	
15	3S9-H2530-01	制动开关总成 STOP SWITCH ASSY	1	1	1	1	
16	2B9-H2590-20	电缆总成 WIRE HARNESS ASSY	1		1	1	
	13R-H2590-70	电缆总成 WIRE HARNESS ASSY		1			
	13R-H2590-80	电缆总成 WIRE HARNESS ASSY	1		1	1	加热器车用
	13R-H2590-90	电缆总成 WIRE HARNESS ASSY		1			加热器车用
17	5VL-H1980-10	二极管总成 DIODE ASSY	1	1	1	1	
18	90464-35820	线夹 CLAMP	1		1	1	
19	5VL-H3936-00	开关导线箍带 BAND, SWITCH CORD	2	2	2	2	
20	5VL-H5752-01	燃油表传感装置组合 SENDER UNIT ASSY, FUEL METER	1	1	1	1	
21	4FP-H5753-01	传感垫圈 GASKET, SENDER UNIT	1	1	1	1	
22	90105-05832	凸缘螺栓 BOLT, FLANGE	4	4	4	4	

FIG. 49 电气系统 2

ELECTRICAL 2

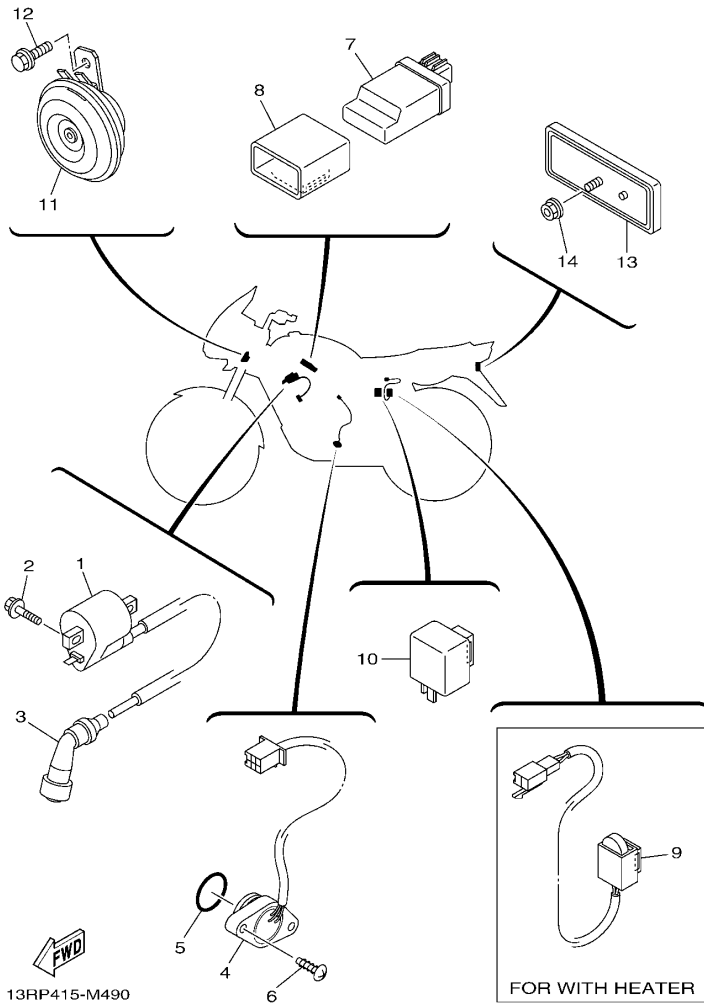

参照 号码	零件号码 PART NO.	零件名称 DESCRIPTION	13RU	13RV	13RW	13RX	备注 REMARKS
1	1BK-H2310-00	点火线圈组合 IGNITION COIL ASSY	1	1	1	1	
2	95022-06016	凸缘螺栓 BOLT, FLANGE	2	2	2	2	
3	1BK-H2370-00	火花塞帽组合 PLUG CAP ASSY	1	1	1	1	
4	13R-H2540-00	空挡开关组合 NEUTRAL SWITCH ASSY	1	1	1	1	
5	93210-23801	O型环 O-RING	1	1	1	1	
6	90154-05802	夹紧螺钉 SCREW, BINDING	2	2	2	2	
7	1BK-H5540-00	CDI 总成 C.D.I. UNIT ASSY	1	1	1	1	
8	5VL-H5546-00	箍带 BAND	1	1	1	1	
9	1BK-H2560-00	温控开关组合 THERMO SWITCH ASSY	1	1	1	1	加热器车用
10	18C-H3350-01	闪烁继电器组合 FLASHER RELAY ASSY	1	1	1	1	
11	1BK-H3371-10	电喇叭 HORN	1		1	1	
	13R-H3371-00	电喇叭 HORN		1			
12	95822-06012	凸缘螺栓 BOLT, FLANGE	1	1	1	1	
13	4FP-H5130-21	后反射镜组合 REAR REFLECTOR ASSY	1	1	1	1	
14	95702-05500	螺母 NUT, FLANGE	1	1	1	1	

零件号码索引
NUMERICAL INDEX

零件号码 PART NO.	参照 号码	零件号码 PART NO.	参照 号码	零件号码 PART NO.	参照 号码	零件号码 PART NO.	参照 号码	零件号码 PART NO.	参照 号码	零件号码 PART NO.	参照 号码
2UJ-11133-10	1 - 2	5VL-E2118-00	3 - 6	5VL-E5512-00	11 - 3	5VL-E8531-00	14 - 10	5VL-F3141-40	23 - 17	5VL-F3435-00-35	21 - 9
22F-11134-10	1 - 3	1BK-E2119-00	3 - 3	5VL-E5517-00	11 - 7	5VL-E8535-00	14 - 11		24 - 7		22 - 9
5VL-12210-10	4 - 15	1BK-E2121-00	3 - 2	5VL-E5521-00	11 - 4	1SF-E8541-00	14 - 1		24 - 17	3S9-F3441-00	21 - 13
5YY-14103-00	7 - 17	5VL-E2151-00	3 - 8	5VL-E5532-00	11 - 5	1JD-E8542-00	14 - 2	4GU-F3144-00	23 - 4		22 - 13
18D-14105-00	7 - 19	5VL-E2156-00	3 - 10	1BK-E5580-00	11 - 9	13R-F1110-20	17 - 1		23 - 14	5VL-F414H-00	25 - 32
18D-14112-00	7 - 3	13R-E2171-00	4 - 1	5VL-E5598-00	4 - 13	13R-F1110-30	17 - 1		24 - 4	13R-F4170-01	25 - 33
22F-14139-00	7 - 23	5VL-E2176-10	4 - 7	1JP-E6111-00	12 - 1	1BK-F1316-00	17 - 2		24 - 14	18C-F4180-01	25 - 34
5P0-14141-13	7 - 6	5VL-E2213-10	4 - 16	1JP-E6150-10	12 - 6	5VL-F1317-00	17 - 7	4GU-F3145-00	23 - 3	2TY-F4181-00	8 - 9
5P0-14142-17	7 - 21	5VL-E2231-10	4 - 11	1JP-E6154-00	12 - 7	5VL-F1318-00	17 - 8		23 - 13	4FP-F4181-00	25 - 2
5HK-14147-00	7 - 9	5VL-E2241-10	4 - 12	5VL-E6164-10	12 - 17	5VL-F137U-20	25 - 22		24 - 3	5VL-F4182-00	25 - 4
49P-14150-00	7 - 22	5VL-E3300-01	5 - 1	1JP-E6300-10	12 - 5	5VL-F137V-20	25 - 24		24 - 13	5VL-F4183-00	25 - 3
353-14186-00	7 - 10	5VL-E3324-00	5 - 10	1JP-E6321-00	12 - 9	5VL-F1513-01	18 - 2	5VL-F3154-00	23 - 9	5VL-F4216-11	25 - 28
5LW-14191-00	7 - 13	5VL-E3325-00	5 - 2	1JP-E6324-00	12 - 10	5VL-F1518-01	18 - 4		23 - 19	5VL-F4311-00	25 - 19
18C-14196-00	7 - 20	2D0-E3411-00	5 - 9	1JP-E6333-00	12 - 22	5VL-F1541-00	18 - 5		24 - 9	13R-F4312-00	25 - 39
5YY-14197-00	7 - 12	5VL-E3451-00	5 - 11	1JP-E6337-00	12 - 13	3D9-F1611-10	18 - 7		24 - 19	13R-F4313-00	25 - 40
3G2-14231-22	7 - 8	18C-E3575-01	6 - 18	1JP-E6351-00	12 - 11	5VL-F1621-00	18 - 10	5VL-F3165-01	21 - 12	1BK-F4314-00	25 - 41
18C-14261-00	7 - 7	18C-E3586-10	6 - 2	5VL-E6357-01	12 - 21	13R-F1746-00	19 - 4		22 - 12	1BK-F4315-00	25 - 42
18D-14589-10	7 - 4	1SF-E410A-00	7 - 15	1JP-E6371-00	12 - 8	5VL-F1746-00	19 - 12	5VL-F3170-01	23 - 6	5VL-F4481-00	26 - 12
18C-1490J-00	7 - 5	1BK-E4410-00	6 - 5	5VL-E6381-02	12 - 22	3D9-F1747-00	19 - 13		23 - 16	5VL-F4500-01	25 - 8
5CY-14951-00	7 - 27	1BK-E4411-00	6 - 6	5VL-E7121-00	13 - 3	5VL-F1778-00	19 - 6		24 - 6	13R-F4510-00	25 - 7
18D-14985-00	7 - 24	1BK-E4412-00	6 - 7	5VL-E7131-00	13 - 4		25 - 27		24 - 16	5VL-F4512-01	25 - 11
5LW-14994-00	7 - 14	2D0-E4417-00	6 - 16	5VL-E7141-00	13 - 5	3D9-F177G-01	19 - 11	13R-F3174-00	22 - 15	5VL-F4515-00	25 - 13
5LW-24411-00	7 - 2	2D0-E4424-00	6 - 15	5VL-E7151-00	13 - 2	5VL-F1780-01	19 - 7		21 - 5	5VL-F4523-01	25 - 12
5FU-82103-00	7 - 26	2D0-E4437-00	6 - 10	5VL-E7211-00	13 - 19	5VL-F2110-00-33	20 - 1	13R-F3174-21	21 - 15	5VL-F4524-01	25 - 14
5FU-83790-00	7 - 25	2D0-E443E-00	6 - 14	5VL-E7221-00	13 - 14	5VL-F2123-00	20 - 3	4FP-F317J-00	21 - 17	5VL-F4534-01	25 - 9
5VL-E1111-11	1 - 1	2D0-E4450-00	6 - 8	5VL-E7231-00	13 - 15	5VL-F2127-00	20 - 6		22 - 17	18C-F4610-02	25 - 18
5VL-E1111F-00	4 - 5	2D0-E4452-00	6 - 11	5VL-E7241-00	13 - 18	5VL-F2128-01	20 - 4	5VL-F331X-01	23 - 21	1BK-F4682-00	25 - 38
3D9-E113F-00	8 - 14	1BK-E4453-00	6 - 9	5VL-E7251-00	13 - 13	5VL-F2141-01	20 - 7		24 - 21	5VL-F4730-12	26 - 1
5VL-E1161-00	1 - 8	2D0-E4462-00	6 - 12	5VL-E7402-00	13 - 12	5VL-F2151-10	20 - 10	5VL-F3346-01	23 - 23	4TU-F4741-00	8 - 2
5VL-E1166-00	9 - 4	5VL-E4613-00	8 - 10	5VL-E7411-00	13 - 1	5VL-F2210-01	20 - 13		24 - 23		26 - 2
4FP-E1167-00	9 - 3	18C-E4703-30	8 - 1	3D9-E7456-01	13 - 27	5VL-F2311-00	20 - 11	5VL-F334G-11	21 - 21	5VL-F4796-01	26 - 14
1BK-E1181-00	1 - 16	18C-E4758-00	8 - 3	5VL-E7471-00	13 - 10	13R-F3102-00	23 - 1	5VL-F3389-01	21 - 18	5VL-F5111-00-35	27 - 1
5VL-E1185-10	1 - 7	18C-E4799-00	8 - 5	5VL-E8101-12	15 - 7	13R-F3102-10	24 - 1		22 - 18	1KL-F5118-00	27 - 29
5VL-E1186-00	1 - 11	18D-E4803-00	8 - 23		16 - 7	13R-F3103-00	23 - 11	4FP-F3395-10	21 - 20		29 - 26
1BK-E1310-00	1 - 19	5VL-E4815-00	8 - 15	5VL-E8110-01	16 - 9	13R-F3103-10	24 - 11	4FP-F3411-00	21 - 2	4GU-F5118-00	28 - 11
5VL-E1351-10	1 - 20	18C-E4873-00	8 - 20	5VL-E8110-12	15 - 9	13R-F3106-00	23 - 2		22 - 2	4GU-F511X-01	28 - 9
5VL-E1422-00	2 - 6	3D9-E4881-00	8 - 17	1KL-E8113-00	15 - 10	13R-F3106-10	24 - 2	4FP-F3411-10	23 - 22	5VL-F5121-01-35	27 - 5
5VL-E1454-10	2 - 12	13R-E4882-00	8 - 22		16 - 10	13R-F3107-00	23 - 12		24 - 22	5VL-F5121-01-8L	29 - 5
5VL-E1496-00	2 - 18	3D9-E4883-00	8 - 25	5VL-E8140-00	15 - 1	13R-F3107-10	24 - 12	1KL-F3412-00	21 - 1	1KL-F5135-00	27 - 9
5VL-E1533-00	2 - 8	1SF-E4901-02	7 - 1		16 - 1	5VL-F3110-01	23 - 5		22 - 1		29 - 9
5VL-E1631-00	2 - 14	5VL-E5191-00	10 - 8	4FP-E8177-00	15 - 3		23 - 15	4FP-F3412-00	21 - 3	1KL-F5136-00	27 - 10
5VL-E1633-00	2 - 15	5VL-E5362-00	10 - 17		16 - 3		24 - 5		22 - 3		29 - 10
5VL-E1651-00	2 - 5	1SF-E5411-00	10 - 1	1BK-E8185-00	14 - 5		24 - 15	4GU-F3416-00	21 - 5	1KL-F5137-01	27 - 30
5VL-E1681-00	2 - 3	18C-E5418-00	10 - 10	5VL-E8337-00	15 - 2	5VL-F3111-20	23 - 8		22 - 5		29 - 27
1BK-E2111-00	3 - 1	1SF-E5421-00	10 - 12		16 - 2		23 - 18	5VL-F3418-01	21 - 7	1KL-F5138-00	27 - 11
1SF-E2113-00	3 - 5	5VL-E5441-01	9 - 11	2D0-E8511-00	14 - 7		24 - 8		22 - 7		29 - 11
5VL-E2116-01	3 - 4	5VL-E5451-10	10 - 2	2D0-E8512-00	14 - 8		24 - 18	5VL-F341E-10	21 - 4	1KL-F5149-01	27 - 15
5VL-E2117-01	3 - 7	5VL-E5461-10	10 - 13	2D0-E8513-00	14 - 9	5VL-F3141-40	23 - 7		22 - 4		29 - 15

零件号码索引
NUMERICAL INDEX

零件号码 PART NO.	参照 号码	零件号码 PART NO.	参照 号码	零件号码 PART NO.	参照 号码	零件号码 PART NO.	参照 号码	零件号码 PART NO.	参照 号码	零件号码 PART NO.	参照 号码
4FP-F5155-11	27 - 17	5VL-F5388-01	31 - 39	46S-F6312-00	35 - 11	4FP-H2151-00	48 - 8	5VL-H3550-23	42 - 17	13R-HA251-30	42 - 2
	29 - 17		32 - 36	2D0-F6312-01	34 - 16	1BK-H2310-00	49 - 1	5VL-H357H-00	42 - 15	13R-HA252-30	42 - 3
1BK-F5168-00-8L	29 - 1		33 - 36		35 - 11	1BK-H2370-00	49 - 3	13R-H358L-00	42 - 6	13R-HA253-10	42 - 4
3D9-F5168-00-8L	28 - 1	5VL-F53C0-10	31 - 42		35 - 12	13R-H2501-10	48 - 11	5VL-H3912-00	46 - 18	3D9-W0041-02	36 - 2
5VL-F5181-01	27 - 28		32 - 39	15F-F6331-00	34 - 17	3S9-H2530-01	48 - 15		47 - 11	45S-W0045-00	30 - 6
	29 - 25		33 - 39		35 - 12	13R-H2540-00	49 - 4	5VL-H3922-00	46 - 6	45S-W0047-00	30 - 5
5VL-F5181-11	28 - 7	5LK-F5412-01	31 - 22	5VL-F6335-11	34 - 5	1BK-H2560-00	49 - 9	5VL-H3922-21	36 - 6	45S-W0048-01	30 - 7
4GU-F5190-12	28 - 8		32 - 22		35 - 5	2B9-H2590-20	48 - 16	4TU-H3936-00	46 - 23	45S-W0057-00	30 - 4
5VL-F5311-00-35	31 - 1		33 - 22	5VL-F6341-11	34 - 8	13R-H2590-70	48 - 16		47 - 16	5VL-W1140-10	2 - 1
5VL-F5321-01-35	31 - 8	5VL-F5445-01	31 - 20	5VL-F6372-01	34 - 6	13R-H2590-80	48 - 16	5VL-H3936-00	48 - 19	5VL-W1141-10	2 - 2
5VL-F5321-01-8L	32 - 8		32 - 20		34 - 9	13R-H2590-90	48 - 16	13R-H3972-00	46 - 11	5VL-W1161-00	2 - 17
	33 - 8		33 - 20		35 - 6	3D9-H2599-00	38 - 10		47 - 4	5VL-W137W-00-P7	25 - 21
1BK-F5338-00-8L	33 - 7	3D9-F580U-01	30 - 3	1BK-F7111-00	37 - 1	4FP-H2911-00	46 - 17	13R-H3972-10	47 - 4	5VL-W137X-00-P7	25 - 23
3D9-F5338-00-8L	32 - 1	3D9-F582U-00	30 - 1	5VL-F7112-11	37 - 2		47 - 10	13R-H3975-00	46 - 14	15F-W1510-00	9 - 1
4GU-F533A-01	27 - 22	4KL-F5852-00	36 - 4	5VL-F7115-01	37 - 3	5VL-H2917-11	46 - 22		47 - 7	13R-W2411-03-P1	25 - 1
	29 - 22	4KL-F5854-00	36 - 3	15F-F7211-00	37 - 5		47 - 15	5VL-H3980-01	47 - 3	5VL-W2533-21	27 - 6
	31 - 16	3D9-F5865-01	36 - 10	5VL-F7231-01	37 - 7	4FP-H2921-00	46 - 5	5VL-H3980-21	46 - 10		29 - 6
	32 - 16	5VL-F5867-00	36 - 9	5VL-F7311-00	37 - 17	5D1-H3310-00	41 - 1	5VL-H4145-00	43 - 10		31 - 9
	33 - 16	3D9-F586F-01	36 - 8	15F-F7411-00	37 - 13	3D9-H3311-10	41 - 4	5VL-H4159-10	43 - 7		32 - 9
4GU-F5351-02	27 - 20	5VL-F5872-11	36 - 11	5VL-F7413-00	37 - 15		41 - 8	5VL-H4163-00	43 - 11		33 - 9
	29 - 20	5VL-F5875-01	36 - 16	5VL-F7414-00	37 - 33		41 - 10	5VL-H4164-00	43 - 12	13R-W2835-01-P0	38 - 1
	31 - 12	5VL-F5876-00	36 - 17	5VL-F7430-01	37 - 24		41 - 14	13R-H4300-00	44 - 1	5VL-W471K-07-P3	26 - 4
	32 - 12	5VL-F5886-00	36 - 15	5VL-F7433-00	37 - 25	3D9-H3318-10	41 - 17	5VL-H4300-23	43 - 1	5VL-W472K-07-P3	26 - 5
	33 - 12	5VL-F5887-00	36 - 14	5VL-F7440-01	37 - 27	5D1-H3320-00	41 - 5	13R-H4303-00	44 - 2	5VL-W4756-00-P3	26 - 6
5VL-F5355-01	31 - 13	3D9-F589F-01	36 - 7	5VL-F7444-00	37 - 28	3D9-H3330-10	41 - 9	5VL-H4310-22	43 - 4	5VL-W5304-01	27 - 23
	32 - 13	4KL-F589H-01	36 - 5	5VL-F7445-01	37 - 26	3D9-H3333-10	41 - 3	5VL-H4312-10	43 - 6		31 - 25
	33 - 13	4S5-F5917-00	30 - 12		37 - 29		41 - 7	5VL-H4314-20	43 - 2	2B9-W583T-02	36 - 1
1KL-F5364-00	31 - 5	4S5-F5919-00	30 - 11	5VL-F7452-00	37 - 21		41 - 12	5VL-H4314-60	44 - 3	13R-W8381-00	38 - 2
	32 - 5	4S5-F5921-01	30 - 8	3D9-F7462-00	37 - 22		41 - 16	5VL-H4315-21	43 - 5	5VL-Y1153-20	2 - 7
	33 - 6	4S5-F5924-01	30 - 13	5VL-F8100-10	17 - 15	3D9-H333A-00	41 - 2	5VL-H4330-22	43 - 9	5VL-Y1215-00	3 - 9
	31 - 17	4S5-F5925-00	30 - 14	5VL-F811G-01	17 - 16		41 - 15	13R-H4337-00	44 - 5	5VL-Y1635-10	12 - 14
	32 - 17	4S5-F5937-00	30 - 9	5VL-F8215-01	38 - 5	3D9-H3340-10	41 - 13	5VL-H4347-10	43 - 3	5VL-Y2151-03-P3	18 - 1
	33 - 17	4S5-F5939-00	30 - 10	13R-F8336-00	38 - 6	3D9-H334A-00	41 - 6	13R-H4378-00	44 - 4	5VL-Y2171-44-3X	19 - 1
5VL-F5371-00	31 - 30	13R-F6111-00	34 - 1	13R-H1410-00	39 - 2		41 - 11	5VL-H4526-00	43 - 8	5VL-Y2171-51-3X	19 - 1
	32 - 27		35 - 1	13R-H1410-10	39 - 2	18C-H3350-01	49 - 10	3D9-H4700-00	45 - 1	3D9-Y2172-40-3X	19 - 3
	33 - 27	18C-F6240-00	34 - 2	1BK-H1450-00	39 - 1	13R-H3371-00	49 - 11	3D9-H4704-00	45 - 5	2B9-Y2477-00	26 - 11
5VL-F5377-01	31 - 38		35 - 2	4FP-H1801-00	40 - 2	1BK-H3371-10	49 - 11	3D9-H4714-10	45 - 3	13R-Y8250-03	48 - 12
	32 - 35	5VL-F6241-10	34 - 3	4FP-H1828-01	40 - 5	13R-H3500-30	42 - 1	3D9-H4721-10	45 - 2	90101-06848	27 - 18
	33 - 35		35 - 3	5VL-H183G-01	40 - 7	13R-H3509-00	42 - 10	3D9-H4724-10	45 - 4		29 - 18
5VL-F5381-01	31 - 35	13R-F6280-00	34 - 10	1JP-H1890-00	40 - 1	5VL-H350E-00	42 - 12	5VL-H5110-30	23 - 10		31 - 14
	32 - 32		35 - 7	5VL-H1940-01	48 - 7	4FP-H3517-10	42 - 11		23 - 20		32 - 14
	33 - 32	5VL-F628J-10	34 - 4	2D0-H1960-10	48 - 5	13R-H3524-00	42 - 8		24 - 10		33 - 14
5VL-F5386-01	31 - 37		35 - 4	5VL-H1980-10	48 - 17	13R-H353G-00	42 - 5		24 - 20	90101-08820	4 - 9
	32 - 34	13R-F6290-00	34 - 11	13R-H2100-10	48 - 1	18C-H353H-00	42 - 14	4FP-H5130-21	49 - 13	90105-05832	48 - 22
	33 - 34		35 - 8	5VL-H2109-00	37 - 14	5VL-H353S-00	42 - 7	1BK-H5540-00	49 - 7	90105-08724	1 - 13
5VL-F5387-01	31 - 19	46S-F6311-00	35 - 9	5VL-H2115-00	48 - 3	5VL-H3543-00	42 - 13	5VL-H5546-00	49 - 8	90105-08873	17 - 12
	32 - 19	2D0-F6311-01	34 - 14	5VL-H2116-00	48 - 4	1BK-H354P-00	42 - 9	5VL-H5752-01	48 - 20	90105-08874	17 - 4
	33 - 19		35 - 9	5VL-H2131-01	48 - 2	5VL-H3550-12	42 - 17	4FP-H5753-01	48 - 21	90105-088E4	17 - 9

零件号码索引
NUMERICAL INDEX

零件号码 PART NO.	参照 号码	零件号码 PART NO.	参照 号码	零件号码 PART NO.	参照 号码	零件号码 PART NO.	参照 号码	零件号码 PART NO.	参照 号码	零件号码 PART NO.	参照 号码
90105-088E5	17 - 10	90179-08639	33 - 23	90208-26800	2 - 9	90480-20M05	8 - 27	93102-18806	29 - 3	93410-19831	27 - 16
90105-088E6	17 - 13	90179-08830	17 - 6	90215-12211	12 - 18	90480-24186	19 - 2	93102-20812	13 - 24		29 - 16
90105-10831	30 - 15		17 - 11	90249-06800	37 - 30	90501-06805	14 - 3	93102-20857	28 - 4	93410-20809	13 - 7
90109-06850	46 - 7		17 - 14	90249-12808	34 - 12	90501-08803	34 - 7	93104-07811	27 - 12		13 - 17
	46 - 19	90179-08862	46 - 2		37 - 11	90501-10806	37 - 10		29 - 12	93440-10109	1 - 4
	47 - 12		46 - 4	90267-48854	18 - 3	90501-16001	2 - 10	93104-22802	32 - 3	93450-16812	2 - 16
90109-08847	31 - 31		47 - 2	90280-03017	2 - 20	90506-12801	27 - 7	93104-22803	31 - 4	93503-16824	12 - 20
	32 - 28	90179-10807	17 - 5	90282-05001	12 - 2		29 - 7		33 - 4	93604-08800	2 - 11
	33 - 28	90179-12813	12 - 4	90340-12097	5 - 7		31 - 10	93105-47802	27 - 21	93604-10837	14 - 6
90109-08848	31 - 32	90179-12863	2 - 22	90340-14810	10 - 6		32 - 10		29 - 21	93608-30839	15 - 8
	32 - 29	90179-25806	21 - 6	90386-18801	20 - 2		33 - 10	93106-26804	31 - 24		16 - 8
	33 - 29		22 - 6	90387-06023	8 - 8	90506-15802	27 - 8		32 - 24	93822-14813	13 - 26
90109-08864	31 - 21	90183-050A6	44 - 6	90387-06837	45 - 7		29 - 8		33 - 24	93900-00826	28 - 6
	32 - 21	90185-10807	27 - 32	90387-06879	25 - 30		31 - 11	93109-18804	20 - 5		32 - 26
	33 - 21		29 - 29	90387-068H9	25 - 36		32 - 11	93210-14817	10 - 7	94109-18805	31 - 26
90109-10849	37 - 19		37 - 20	90387-12840	27 - 34		33 - 11	93210-14818	27 - 31		33 - 25
90111-06015	8 - 6	90201-05802	21 - 23		29 - 31	90506-29800	37 - 18		29 - 28	94109-18807	32 - 25
90111-08805	30 - 2	90201-06850	19 - 10	90387-15803	11 - 1	90506-32800	37 - 4	93210-19809	10 - 18	94127-18823	27 - 25
90119-06811	19 - 14	90201-068C2	48 - 10	90387-15809	31 - 2	90508-16800	12 - 23	93210-23801	49 - 5		29 - 23
90119-06869	6 - 17		48 - 14		32 - 2	90508-32801	15 - 5	93210-26668	40 - 4	94127-18828	28 - 5
	18 - 8	90201-07641	5 - 4		33 - 1		16 - 5	93210-30801	6 - 3	94227-18808	27 - 26
	26 - 3	90201-07836	27 - 13	90387-158K1	28 - 10	90508-40801	37 - 6	93210-42803	31 - 6		29 - 24
	26 - 9		29 - 13	90387-16804	4 - 3	90560-12828	27 - 2		33 - 5		31 - 27
90123-08813	46 - 1	90201-08326	4 - 8	90401-10811	36 - 12		29 - 2	93210-42807	32 - 4		33 - 26
	46 - 3	90201-08830	43 - 14	90430-05800	25 - 17	90560-15293	28 - 2	93210-44812	1 - 12	94327-18800	27 - 27
	47 - 1	90201-08840	8 - 13	90430-06817	1 - 6	91312-05010	13 - 28	93210-55669	40 - 3		31 - 29
90149-05800	38 - 3	90201-088C3	1 - 14		4 - 18	91312-06012	4 - 6	93210-79802	1 - 9	94416-18803	27 - 24
90149-06833	8 - 4	90201-088P2	25 - 5	90430-12227	5 - 8	91312-06014	39 - 4	93306-002YM	4 - 4	94418-18802	31 - 28
	38 - 7	90201-108C7	20 - 14	90450-44804	6 - 1	91312-06020	6 - 4	93306-003YS	4 - 2	94568-A4090	4 - 10
90151-06818	14 - 4		27 - 33	90462-16801	9 - 6		8 - 11	93306-054X3	31 - 18	94668-E2001	31 - 43
90153-06803	1 - 5		29 - 30	90464-12803	18 - 9		48 - 13		32 - 18		32 - 40
90153-08804	31 - 41	90201-108J9	36 - 13	90464-23811	25 - 46	91312-06025	39 - 3		33 - 18		33 - 40
90153-08804	32 - 38	90201-122H1	2 - 21	90464-35820	48 - 18	91312-06030	39 - 3	93306-201Y8	13 - 8	94700-00869	1 - 15
	33 - 38		12 - 3	90467-07029	25 - 44	91312-06090	1 - 18	93306-202XN	2 - 19	95022-06016	4 - 17
90154-05802	49 - 6	90201-12819	20 - 9	90467-08806	25 - 45	91312-08016	11 - 10	93306-202XP	13 - 25		8 - 16
90155-06800	5 - 6	90201-15700	13 - 20	90467-09006	25 - 43	91402-20012	31 - 34	93306-202Y4	28 - 3		25 - 37
90157-03800	25 - 15	90201-20266	13 - 6	90467-09854	25 - 20		32 - 31	93306-203YT	13 - 9		36 - 18
90159-05837	44 - 7		13 - 16	90467-12828	9 - 5		33 - 31	93306-204YD	13 - 23		42 - 16
90159-06820	25 - 16	90201-20272	13 - 22	90467-14802	8 - 26		37 - 8	93306-205YP	2 - 13		49 - 2
90159-06830	20 - 12	90201-20844	27 - 14	90467-16807	8 - 18	92012-06012	8 - 24	93306-252XA	31 - 7	95022-06020	1 - 10
90170-12060	12 - 19		29 - 14	90467-18806	8 - 21	92902-06200	12 - 15		32 - 7	95022-06025	36 - 19
90176-10810	20 - 15	90201-228F6	19 - 8	90467-19801	8 - 19		37 - 9		33 - 3		40 - 8
90176-22802	21 - 11	90201-258D7	11 - 8	90480-01868	26 - 10		37 - 31	93306-252YY	31 - 3	95022-06030	9 - 7
	22 - 11	90202-06803	38 - 8	90480-12581	8 - 7	93101-10800	10 - 19		32 - 6	95022-06035	10 - 4
90179-06826	34 - 13	90202-09800	25 - 31	90480-13018	25 - 35	93101-12803	15 - 4		33 - 2		10 - 15
	37 - 12	90202-26142	21 - 8	90480-13837	19 - 5		16 - 4	93306-301XS	29 - 4	95022-06045	9 - 8
	31 - 23		22 - 8		25 - 26	93102-12812	12 - 24	93306-301Y6	27 - 4		10 - 16
90179-08639	32 - 23	90208-07052	5 - 5	90480-14812	45 - 6	93102-18804	27 - 3	93310-629Y3	2 - 4	95022-06050	10 - 5

零件号码索引
NUMERICAL INDEX

零件号码 PART NO.	参照 号码	零件号码 PART NO.	参照 号码	零件号码 PART NO.	参照 号码	零件号码 PART NO.	参照 号码	零件号码 PART NO.	参照 号码	零件号码 PART NO.	参照 号码
95022-06055	9 - 9	97022-06020	16 - 11								
95022-08035	21 - 14	97522-06525	46 - 9								
	22 - 14		46 - 21								
95022-08040	21 - 10		47 - 14								
	22 - 10	97602-06220	6 - 13								
95023-08030	43 - 13	97702-40014	25 - 25								
95302-06600	12 - 16	97702-50012	26 - 8								
	27 - 19	97880-03008	25 - 10								
	29 - 19	98502-05010	34 - 15								
	31 - 15		35 - 10								
	32 - 15	98507-04008	7 - 11								
	33 - 15	98507-04014	7 - 18								
	45 - 8	98507-05008	7 - 16								
	48 - 9	98507-05022	46 - 12								
95302-08800	43 - 15		47 - 5								
95312-08600	31 - 40	98507-05025	46 - 15								
	32 - 37		47 - 8								
	33 - 37	98507-05042	46 - 13								
95602-06100	46 - 8		47 - 6								
	46 - 20	98507-05046	46 - 16								
	47 - 13		47 - 9								
95602-12200	20 - 8	98512-06010	10 - 9								
95602-14200	28 - 12	98512-06012	11 - 6								
	31 - 36		13 - 11								
	32 - 33	98512-06016	25 - 29								
	33 - 33	98902-05008	40 - 6								
95702-05500	38 - 4	98902-06016	10 - 11								
	49 - 14	98902-06020	19 - 9								
95702-08500	31 - 33	99002-05600	5 - 3								
	32 - 30		37 - 32								
95702-08500	33 - 30	99002-10600	15 - 6								
95802-06012	38 - 9		16 - 6								
95802-06020	4 - 14	99009-15400	11 - 2								
	48 - 6		13 - 21								
95812-08016	26 - 13	99009-20500	12 - 25								
95812-08020	8 - 12	99236-00080	26 - 7								
	37 - 16	99530-10114	1 - 17								
	37 - 23		9 - 2								
95812-10080	17 - 3		9 - 10								
95822-06012	21 - 19		10 - 3								
	22 - 19		10 - 14								
	49 - 12										
95822-06016	18 - 6										
	21 - 16										
	22 - 16										
97002-05012	21 - 22										
97002-08016	25 - 6										
97022-06020	15 - 11										

雅马哈纯正用品大集结



① 纯色头盔(全盔)

- BL
- RD
- BK



④ 纯色头盔(半盔)

- BL
- RD
- BK



② 锋利头盔(全盔)

- BL
- RD
- BK
- WH



⑤ 锋利头盔(半盔)

- BL
- RD
- BK
- WH



③ 鹰眼头盔(全盔)

- BL
- RD
- BK



⑥ 飞行盔(半盔)

- BL
- BR
- BK
- WH

编号①: Q01-00001-尺寸代码-颜色代码

编号②: Q01-00003-尺寸代码-颜色代码

编号③: Q01-NS001-尺寸代码-颜色代码

编号④: Q01-00002-尺寸代码-颜色代码

编号⑤: Q01-00004-尺寸代码-颜色代码

编号⑥: Q01-00006-尺寸代码-颜色代码

尺寸	M	L	XL	XXL
尺寸代码	0M	0L	0X	2X



YAMAHA尾箱

编号: Q41-20000-33-BK

YAMAHA尾箱靠背

编号: Q41-20000-33-CC

雅马哈纯正机油大集结



纯正机油

品质保证! 动力之源!

请经销YAMALUBE纯正 机油!



90793-AC421-T1
90793-AC421-G1
SAE 10W-40 (1L)
高等级/通用



90793-AC432-00
SAE 10W-30 (1L)
通用机油



90793-AC423-T2
90793-AC423-G2
SAE 20W-40 (1L)
通用机油



90793-AC427-T1
90793-AC427-G1
SAE 10W-40 (0.8L)
弯梁车专用



90793-AC426-T1
SAE 5W-30 (1L)
冬季专用/通用



90793-AC434-00
SAE 10W-30 (0.8L)
弯梁车专用



90793-AC423-P1
SAE 20W-40 (1L)
通用机油



90793-AC404
GEAR (0.13L)
齿轮油
踏板车专用

友情提示：磨合期后，建议每1500KM更换一次机油(可根据实际使用状况减少里程数)。并清洗机油滤网。