

翻印必究



上海雅马哈建设摩托车销售有限公司

<http://www.yamaha-motor.com.cn/>

第一版 2012年12月



SHANGHAI YAMAHA JIANSHE MOTOR MARKETING CO., LTD.

零件目录

YB125ZEB (1BK5)
YB125ZECB (1BK6)
YB125ZECD (1BK7)
YB125ZECSD (1BK8)
1BK5/1BK6/1BK7/1BK8

1BK-F8198-1M-M1

1M1BK-415M1



YB125ZEB (1BK5)/YB125ZECB (1BK6)/YB125ZECD (1BK7)/YB125ZECSD (1BK8)

1BK5 (钢丝轮/鼓刹/圆灯)

代号	颜色
0580	鸡尾酒鲜红色7



代号	颜色
0903	金属黑色



代号	颜色
0564	浅紫深蓝色



1BK6 (板轮/鼓刹/圆灯)

代号	颜色
0580	鸡尾酒鲜红色7



代号	颜色
0903	金属黑色



代号	颜色
0564	浅紫深蓝色



1BK7 (板轮/碟刹/圆灯)

代号	颜色
0580	鸡尾酒鲜红色7



代号	颜色
0903	金属黑色



代号	颜色
0564	浅紫深蓝色



1BK8 (板轮/碟刹/头罩)

代号	颜色
0580	鸡尾酒鲜红色7



代号	颜色
0903	金属黑色



代号	颜色
0564	浅紫深蓝色



前言

本零件目录记载着封面页所示型号所使用的零件。当您订购更换零件时，请参阅本零件目录并正确指示零件号码和零件名称。

1. 零件目录发行后有变更或附加零件时，将会以雅马哈零件信息通知大家。
建议您应按照雅马哈零件信息修改本零件目录。

2. 省略记号
本文中所记载的省略记号的意思如下。

“UR” 需要指定的零件号码。

“UN” 需要数。

“AP” 选购品

“LM” 当地制造（必需于当地订购的零件）

“F#” 车架号（适用的机器号）

“O/S” 超过尺寸

3. 组件中部件的数量

- 组件的销售零件，如下所示，在零件名称的前面加上（.）的记号来表示。
- 每个部件右侧的数字表示各组件单体内该部件的数量。

零件号码	零件名称	数量	备注
2F5 - 83310 - 60	前闪光灯组合	2	
115 - 83311 - 60	. 灯泡 (6V - 18W)	1	

4. 适用的图形颜色表示在“备注”中，如下所示。

零件号码	零件名称	数量	备注
2N4 - 24110 - 00 - X5	燃油箱组件	2	MXR
3J1 - 24240 - 10	. 燃油箱图形	1	适用于 MXR

5. 请注意插图只用于找寻零件号码时参照，并不适用于组装。组装时，请使用适用的维修手册。

6. 在参照号码前的星号（*）表示其为在第一版后更改的项目。

前言

7. 适用的系列号码

车架系列号

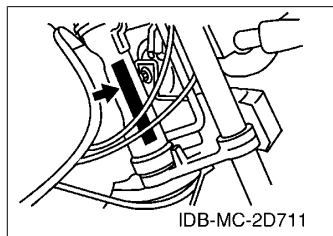

发动机系列号码

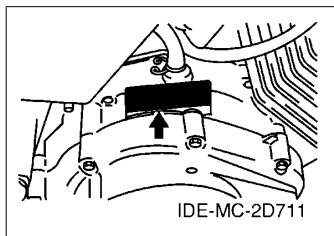

8. 适用的颜色记号 (*标志表示型号颜色。)

省略记号	颜色名称 (英文)	颜色名称	颜色记号
DPBMC (*)	DEEP PURPLISH BLUE METALLIC C	浅紫深蓝色	0564
SL	SILVER	银色	0035
SMX (*)	BLACK METALLIC X	金属黑色	0903
VRC7 (*)	VIVID RED COCKTAIL 7	鸡尾酒鲜红色 7	0580
YB	YAMAHA BLACK	雅马哈黑色	0033

9. 适用的初始系列号码

车架系列号

系列号码	数量栏名称	型号记号

发动机系列号码

系列号码	数量栏名称	型号记号

型号信息

10. 颜色信息

型号代码	颜色类型代码	颜色记号	颜色名称 (英文)	颜色名称	省略记号
1BK5, 1BK6	A	0580	VIVID RED COCKTAIL 7	鸡尾酒鲜红色 7	VRC7
	B	0903	BLACK METALLIC X	金属黑色	SMX
	C	0564	DEEP PURPLISH BLUE METALLIC C	浅紫深蓝色	DPBMC
1BK7, 1BK8	A	0580	VIVID RED COCKTAIL 7	鸡尾酒鲜红色 7	VRC7
	B	0903	BLACK METALLIC X	金属黑色	SMX
	C	0564	DEEP PURPLISH BLUE METALLIC C	浅紫深蓝色	DPBMC

目录

发动机

气缸	1
曲柄·活塞	2
阀门	3
凸轮轴·链条	4
油泵	5
进气门	6
化油器	7
排气装置	8
曲轴箱	9
曲轴箱盖 1	10
起动离合器	11
离合器	12
传动	13
换挡凸轮·拨叉	15
变速杆	16

车体

车架	17
挡泥板	18
侧盖	19
后臂·悬挂	20
操纵系统	21
操纵系统 2	22
前叉(鼓刹)	23
前叉(碟刹)	25
油箱	27
座位	28
前轮	29
前轮 2	31
前轮 3	33
前制动器卡钳	34
后轮	35
后轮 2	37
操纵手柄 钢索(鼓刹)	39
操纵手柄 钢索(碟刹)	40
前主缸	41
搁脚·支架	42
导流罩 1	44
发电机	45

起动电机	46
转向灯	47
转向灯 2	48
仪表	49
前大灯	50
前大灯 2	51
尾灯	52
手柄开关(鼓刹)	53
手柄开关(碟刹)	54
电气系统 1	55
电气系统 2	56

索引

零件号码索引	57
--------	----

CONTENTS

ENGINE

CYLINDER.....	1
CRANKSHAFT & PISTON.....	2
VALVE.....	3
CAMSHAFT & CHAIN.....	4
OIL PUMP.....	5
INTAKE.....	6
CARBURETOR.....	7
EXHAUST.....	8
CRANKCASE.....	9
CRANKCASE COVER 1.....	10
STARTER CLUTCH.....	11
CLUTCH.....	12
TRANSMISSION.....	13
SHIFT CAM & FORK.....	15
SHIFT SHAFT.....	16

CHASSIS

FRAME.....	17
FENDER.....	18
SIDE COVER.....	19
REAR ARM & SUSPENSION.....	20
STEERING.....	21
STEERING 2.....	22
FRONT FORK FOR DRUM BRAKE.....	23
FRONT FORK FOR DISK BRAKE.....	25
FUEL TANK.....	27
SEAT.....	28
FRONT WHEEL.....	29
FRONT WHEEL 2.....	31
FRONT WHEEL 3.....	33
FRONT BRAKE CALIPER.....	34
REAR WHEEL.....	35
REAR WHEEL 2.....	37
STEERING CABLE FOR DRUM BRAKE.....	39
STEERING CABLE FOR DISK BRAKE.....	40
FRONT MASTER CYLINDER.....	41
STAND & FOOTREST.....	42
COWLING 1.....	44
GENERATOR.....	45

STARTING MOTOR.....	46
FLASHER LIGHT.....	47
FLASHER LIGHT 2.....	48
METER.....	49
HEADLIGHT.....	50
HEADLIGHT 2.....	51
TAILLIGHT.....	52
SWITCH & LEVER FOR DRUM BRAKE.....	53
SWITCH & LEVER FOR DISK BRAKE.....	54
ELECTRICAL 1.....	55
ELECTRICAL 2.....	56

INDEX

NUMERICAL INDEX.....	57
----------------------	----

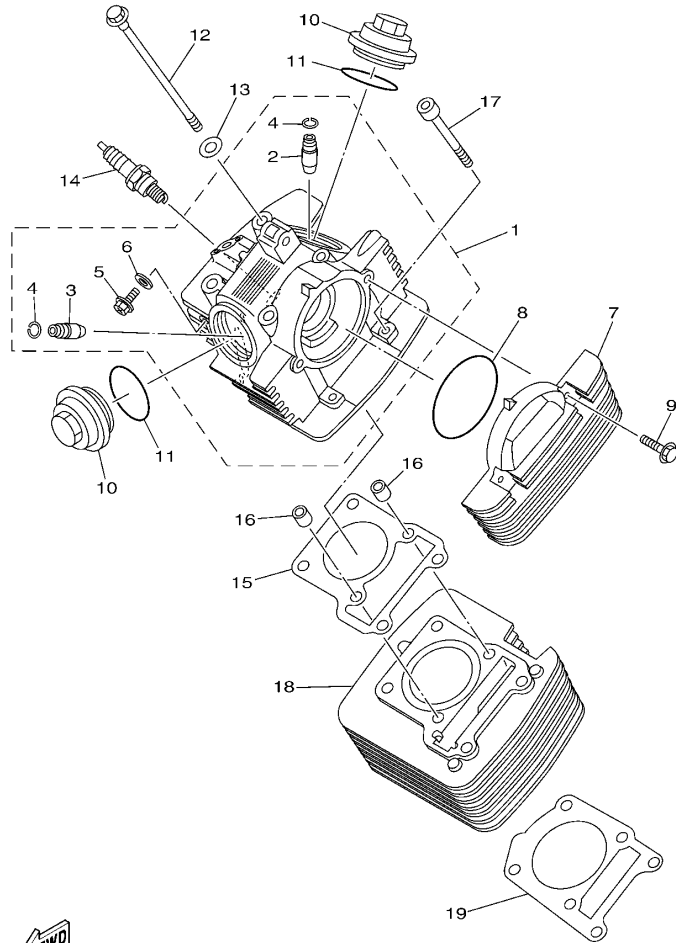

1SF1415-L010

FIG. 1 气缸

CYLINDER

参照 号码	零件号码 PART NO.	零件名称 DESCRIPTION	1BK5	1BK6	1BK7	1BK8	备注 REMARKS
1	5VL-E1111-11	气缸头 1 HEAD, CYLINDER 1	1	1	1	1	
2	5VL-E1133-01	.进气门导管 .GUIDE, VALVE 1	1	1	1	1	
3	5VL-E1134-01	.排气门导管 .GUIDE, VALVE 2	1	1	1	1	
4	93440-10109	.卡环 .CIRCLIP	2	2	2	2	
5	90153-06803	.六角头螺钉 .SCREW, HEXAGON	1	1	1	1	
6	90430-06817	.衬垫 .GASKET	1	1	1	1	
7	5VL-E1185-10	气缸头侧盖 3 COVER, CYLINDER HEAD SIDE 3	1	1	1	1	
8	93210-79802	O型环 O-RING	1	1	1	1	
9	95022-06020	凸缘螺栓 BOLT, FLANGE	2	2	2	2	
10	5VL-E1186-00	气缸头侧盖 2 COVER, CYLINDER HEAD SIDE 2	2	2	2	2	
11	93210-44812	O型环 O-RING	2	2	2	2	
12	90105-08724	凸缘螺栓 BOLT, FLANGE	4	4	4	4	
13	90201-088C3	平垫圈 WASHER, PLATE	4	4	4	4	
14	94700-00869	火花塞 PLUG SPARK (NGK CR6HSA)	1	1	1	1	
15	1BK-E1181-00	气缸头衬垫 1 GASKET, CYLINDER HEAD 1	1	1	1	1	
16	99530-10114	定位销 PIN, DOWEL	2	2	2	2	
17	91312-06090	螺栓 BOLT	2	2	2	2	
18	1BK-E1310-00	气缸 CYLINDER	1	1	1	1	
19	5VL-E1351-10	气缸衬垫 GASKET, CYLINDER	1	1	1	1	

FIG. 2 曲柄·活塞

CRANKSHAFT & PISTON

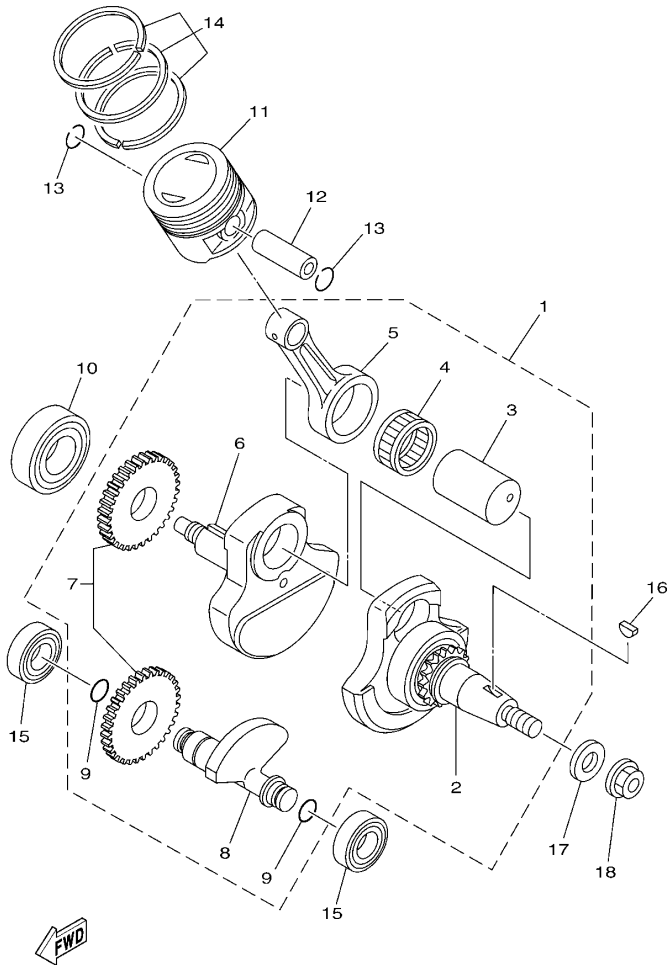

2D0S415-H020

参照 号码	零件号码 PART NO.	零件名称 DESCRIPTION	1BK5	1BK6	1BK7	1BK8	备注 REMARKS
1	5VL-W1140-20	曲柄连杆组合 CRANKSHAFT ASSY	1	1	1	1	
2	5VL-W1141-00	.曲柄 1 .CRANK SUB ASSY 1	1	1	1	1	
3	5VL-E1681-00	.曲柄销 1 .PIN, CRANK 1	1	1	1	1	
4	93310-629Y3	.轴承 .BEARING	1	1	1	1	
5	5VL-E1651-00	.连杆 .ROD, CONNECTING	1	1	1	1	
6	5VL-E1422-00	.曲柄 2 .CRANK 2	1	1	1	1	
7	5VL-Y1153-00	.平衡齿轮总成 .GEAR, BALANCE WEIGHT ASSY.	1	1	1	1	
8	5VL-E1454-00	.平衡轴 1 .WEIGHT 1	1	1	1	1	
9	93210-11809	.O型环 .O-RING	2	2	2	2	
10	93306-205YP	轴承 BEARING	1	1	1	1	
11	5VL-E1631-00	活塞 (STD) PISTON (STD)	1	1	1	1	
12	5VL-E1633-00	活塞销 PIN, PISTON	1	1	1	1	
13	93450-16812	卡环 CIRCLIP	2	2	2	2	
14	5VL-W1161-00	活塞环套件 PISTON RING SET (STD)	1	1	1	1	
15	93306-202XN	轴承 BEARING	2	2	2	2	
16	90280-03017	半圆键 KEY, WOODRUFF	1	1	1	1	
17	90201-122H1	平垫圈 WASHER, PLATE	1	1	1	1	
18	90179-12863	螺母 NUT	1	1	1	1	

FIG. 3 阀门

VALVE

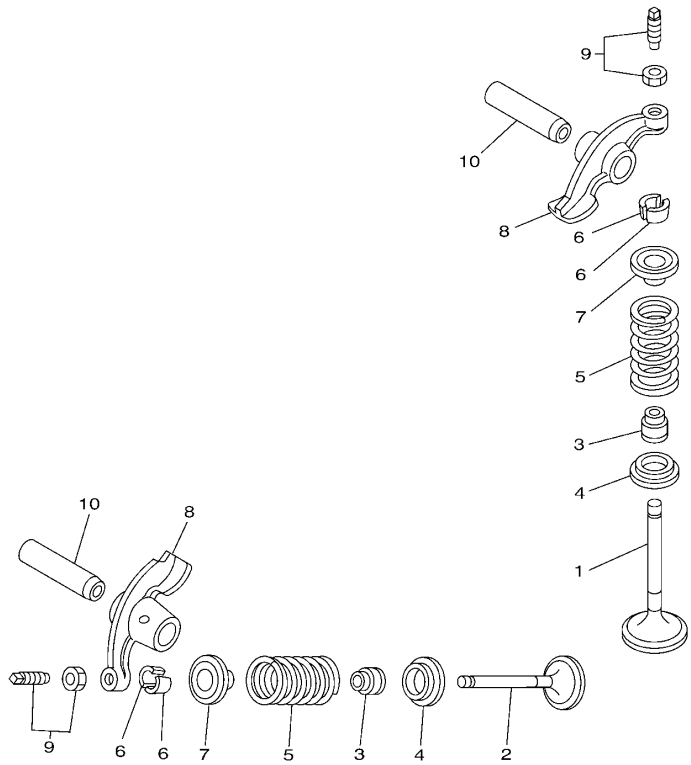

参照 号码	零件号码 PART NO.	零件名称 DESCRIPTION	1BK5	1BK6	1BK7	1BK8	备注 REMARKS
1	1BK-E2111-00	进气门 VALVE, INTAKE	1	1	1	1	
2	1BK-E2121-00	排气门 VALVE, EXHAUST	1	1	1	1	
3	1BK-E2119-00	气门油封 SEAL, VALVE STEM	2	2	2	2	
4	5VL-E2116-01	气门弹簧座 SEAT, VALVE SPRING	2	2	2	2	
5	1SF-E2113-00	气门内弹簧 SPRING, VALVE INNER	2	2	2	2	
6	5VL-E2118-00	气门锁夹 LOCK, VALVE SPRING RETAINER	4	4	4	4	
7	5VL-E2117-01	气门弹簧座 RETAINER, VALVE SPRING	2	2	2	2	
8	5VL-E2151-00	气门摇臂 ARM, VALVE ROCKER	2	2	2	2	
9	5VL-Y1215-00	气门调整螺栓组合 SCREW, VALVE ADJUSTING	2	2	2	2	
10	5VL-E2156-00	摇臂轴 2 SHAFT, ROCKER 2	2	2	2	2	

27S1300-G031

FIG. 4 凸轮轴·链条

CAMSHAFT & CHAIN

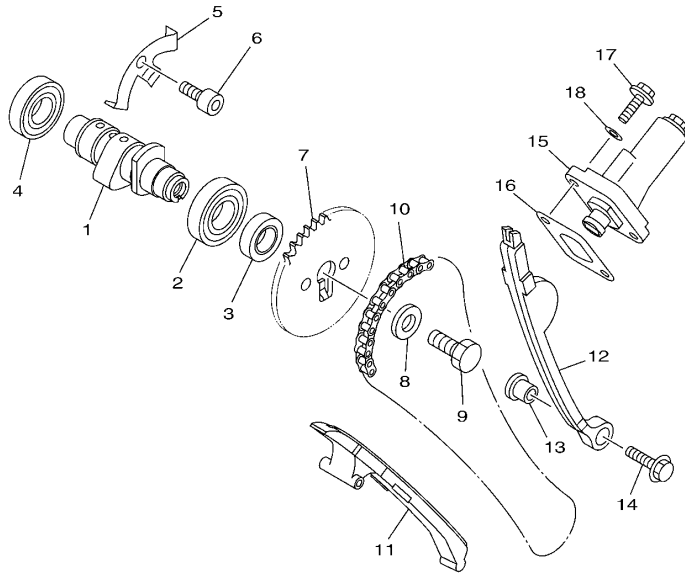

参照 号码	零件号码 PART NO.	零件名称 DESCRIPTION	1BK5	1BK6	1BK7	1BK8	备注 REMARKS
1	1BK-E2171-00	凸轮轴 1 CAMSHAFT 1	1	1	1	1	
2	93306-003YS	轴承 BEARING	1	1	1	1	
3	90387-167L5	轴套 COLLAR	1	1	1	1	
4	93306-002YM	轴承 BEARING	1	1	1	1	
5	5VL-E111F-00	面板 PLATE	1	1	1	1	
6	91312-06012	螺栓 BOLT	1	1	1	1	
7	5VL-E2176-00	链轮 SPROCKET, CAM CHAIN (34T)	1	1	1	1	
8	90201-08326	平垫圈 WASHER, PLATE	1	1	1	1	
9	90101-08820	螺栓 BOLT	1	1	1	1	
10	94568-C1088	链条 CHAIN	1	1	1	1	
11	5VL-E2231-00	导向限位板 1 GUIDE, STOPPER 1	1	1	1	1	
12	5VL-E2241-00	导向限位板 2 GUIDE, STOPPER 2	1	1	1	1	
13	5VL-E5598-00	衬套 COLLAR	1	1	1	1	
14	95802-06020	凸缘螺栓 BOLT, FLANGE	1	1	1	1	
15	5VL-E2210-01	链条张紧器组合 TENSIONER ASSY, CAM CHAIN	1	1	1	1	
16	5VL-E2213-10	张紧器垫片 GASKET, TENSIONER CASE	1	1	1	1	
17	95022-06016	凸缘螺栓 BOLT, FLANGE	2	2	2	2	
18	90430-06817	衬垫 GASKET	2	2	2	2	



1BK1415-J040

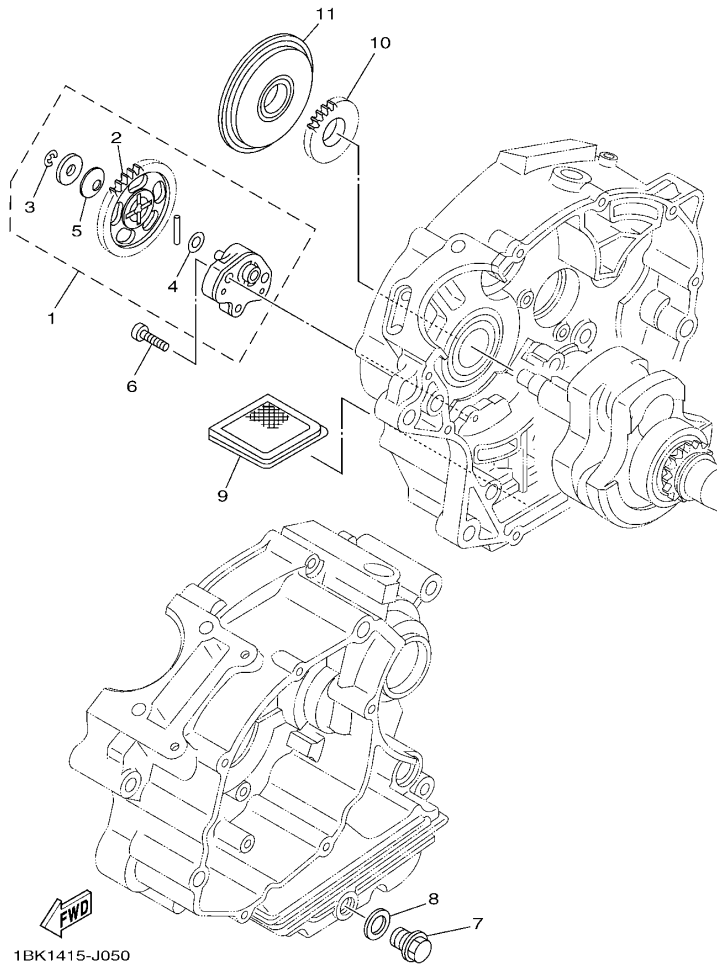

FIG. 5 油泵

OIL PUMP

参照 号码	零件号码 PART NO.	零件名称 DESCRIPTION	1BK5	1BK6	1BK7	1BK8	备注 REMARKS
1	5VL-E3300-01	机油泵总成 OIL PUMP ASSY	1	1	1	1	
2	5VL-E3325-00	.从动齿轮 .GEAR, PUMP DRIVEN	1	1	1	1	
3	99002-05600	.卡环 .CLIP	1	1	1	1	
4	90201-07641	.平垫圈 .WASHER, PLATE	1	1	1	1	
5	90208-07052	.弹性挡圈 .WASHER, CONICAL SPRING	1	1	1	1	
6	90155-06800	螺钉 SCREW, FLAT FILLISTER	2	2	2	2	
7	90340-12097	螺塞 PLUG, STRAIGHT SCREW	1	1	1	1	
8	90430-12227	衬垫 GASKET	1	1	1	1	
9	2D0-E3411-00	机油滤网 STRAINER, OIL	1	1	1	1	
10	5VL-E3324-00	机油泵驱动齿轮 GEAR, PUMP DRIVE	1	1	1	1	
11	5VL-E3451-00	转子过滤器 FILTER, ROTARY	1	1	1	1	

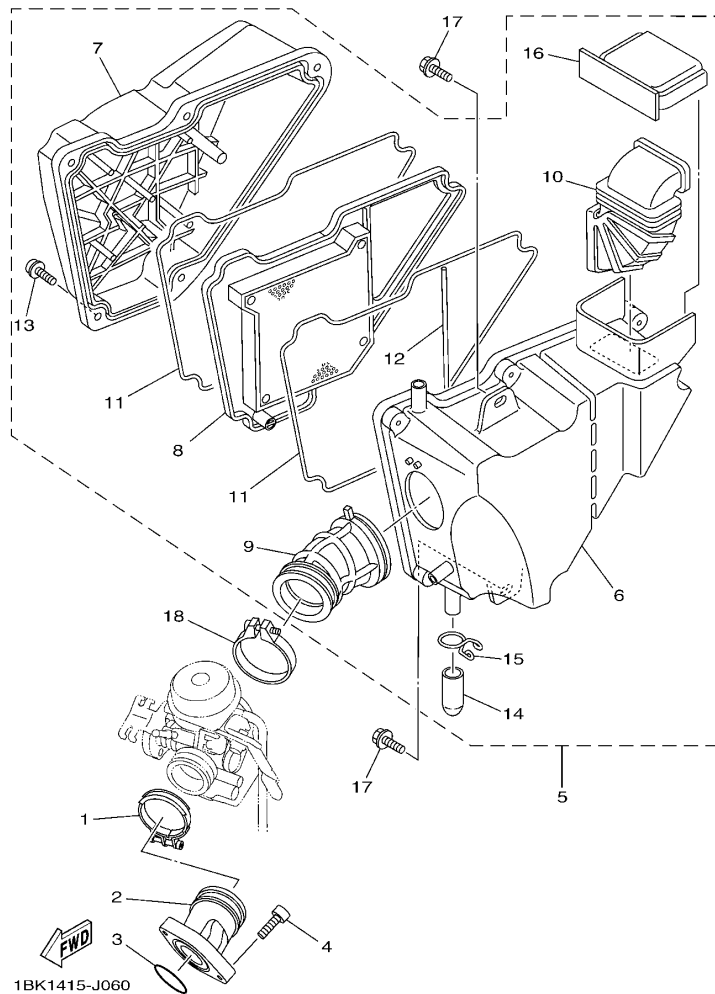
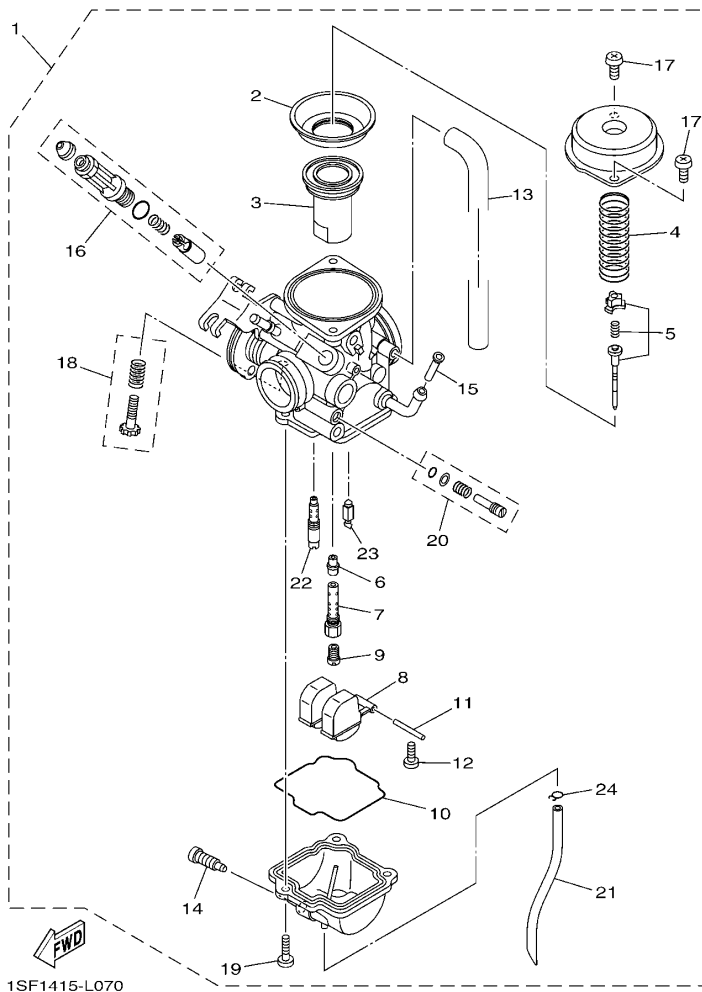

FIG. 6 进气门

INTAKE

参照 号码	零件号码 PART NO.	零件名称 DESCRIPTION	1BK5	1BK6	1BK7	1BK8	备注 REMARKS
1	90450-44804	软管夹组合 HOSE CLAMP ASSY	1	1	1	1	
2	18C-E3586-10	化油器接头 1 JOINT, CARBURETOR 1	1	1	1	1	
3	93210-30801	O型环 O-RING	1	1	1	1	
4	91312-06020	螺栓 BOLT	2	2	2	2	
5	1BK-E4410-00	空气净化器组合 AIR CLEANER ASSY.	1	1	1	1	
6	1BK-E4411-00	.空气净化器箱 1 .CASE, AIR CLEANER 1	1	1	1	1	
7	1BK-E4412-00	.空气净化器箱盖 1 .CAP, CLEANER CASE 1	1	1	1	1	
8	2D0-E4450-00	.空气净化器滤芯组合 .ELEMENT ASSY, AIR CLEANER	1	1	1	1	
9	1BK-E4453-00	.空气净化器接头 1 .JOINT, AIR CLEANER 1	1	1	1	1	
10	2D0-E4437-00	.导管 .DUCT	1	1	1	1	
11	2D0-E4452-00	.密封垫 .SEAL	2	2	2	2	
12	2D0-E4462-00	.密封垫 .SEAL	1	1	1	1	
13	97602-06220	.带垫圈大柱头螺钉 .SCREW, PAN HEAD W/WASHER	5	5	5	5	
14	2D0-E443E-00	.排水管 .PIPE, DRAIN	1	1	1	1	
15	2D0-E4424-00	.卡环 .CLIP, CAP FITTING	1	1	1	1	
16	2D0-E4417-00	.盖 1 .COVER 1	1	1	1	1	
17	90119-06869	带垫螺栓 BOLT, WITH WASHER	2	2	2	2	
18	18C-E3575-01	箍带 BAND	1	1	1	1	



1SF1415-L070

FIG. 7 化油器

CARBURETOR

参照 号码	零件号码 PART NO.	零件名称 DESCRIPTION	1BK5	1BK6	1BK7	1BK8	备注 REMARKS
1	1SF-E4901-01	化油器总成 1 CARBURETOR ASSY 1	1	1	1	1	
2	5LW-24411-00	.隔板 .DIAPHRAGM	1	1	1	1	
3	18D-14112-00	.节气门阀 1 .VALVE, THROTTLE 1	1	1	1	1	
4	18D-14589-10	.弹簧 .SPRING	1	1	1	1	
5	18C-1490J-00	.滚针套件 .NEEDLE SET	1	1	1	1	
6	5P0-14141-13	.主喷嘴 .NOZZLE, MAIN	1	1	1	1	
7	18C-14261-00	.支座 .HOLDER	1	1	1	1	
8	5HK-14985-00	.浮子 .FLOAT	1	1	1	1	
9	3G2-14231-22	.主量孔 (#110) .JET, MAIN (#110)	1	1	1	1	
10	5HK-14147-00	.O型环 .O-RING	1	1	1	1	
11	353-14186-00	.浮子销 .PIN, FLOAT	1	1	1	1	
12	98507-04008	.十字螺钉 .SCREW, PAN HEAD	2	2	2	2	
13	5YY-14197-00	.管 .PIPE	1	1	1	1	
14	5LW-14191-00	.排泄螺钉 .PLUG, DRAIN	1	1	1	1	
15	5LW-14994-00	.滤网 .NET, FILTER	1	1	1	1	
16	1SF-E410A-00	.起动器套件 .STARTER SET	1	1	1	1	
17	98507-05008	.十字螺钉 .SCREW, PAN HEAD	2	2	2	2	
18	5YY-14103-00	.节气门螺钉组件 .THROTTLE SCREW SET	1	1	1	1	
19	98507-04014	.十字螺钉 .SCREW, PAN HEAD	3	3	3	3	
20	18D-14105-00	.混合气调整螺钉组件 .PILOT SCREW SET	1	1	1	1	
21	18C-14196-00	.溢流管 1 .PIPE, OVER FLOW 1	1	1	1	1	
22	5P0-14142-17	.低速量孔 (#17.5) .JET, PILOT (#17.5)	1	1	1	1	
23	49P-14150-00	.针阀组件 .NEEDLE ASSY	1	1	1	1	
24	22F-14139-00	.管夹 .CLIP, PIPE	1	1	1	1	

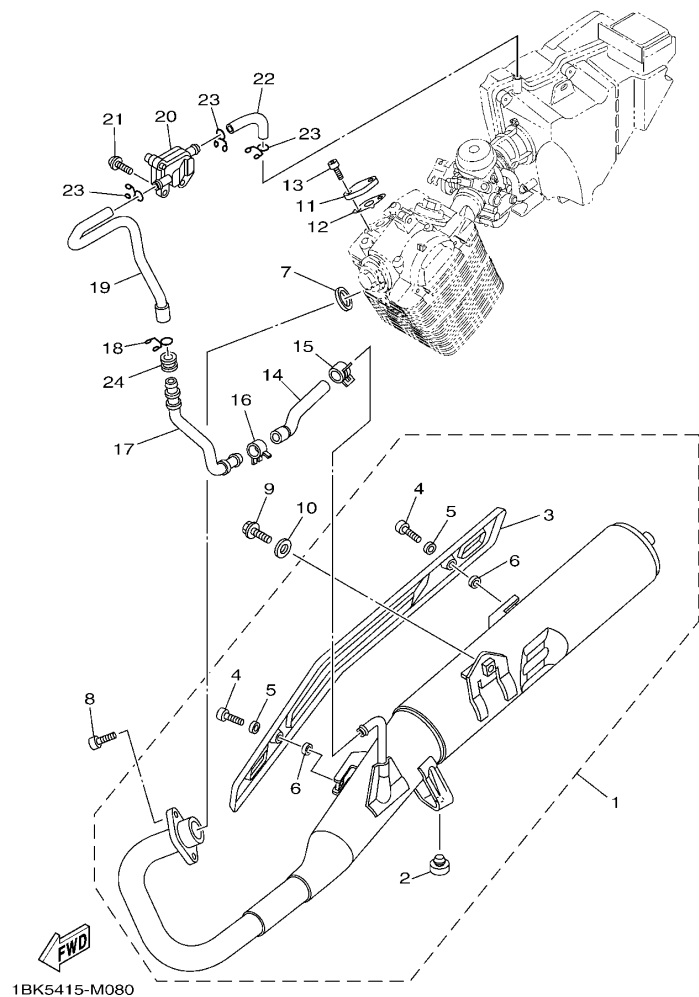
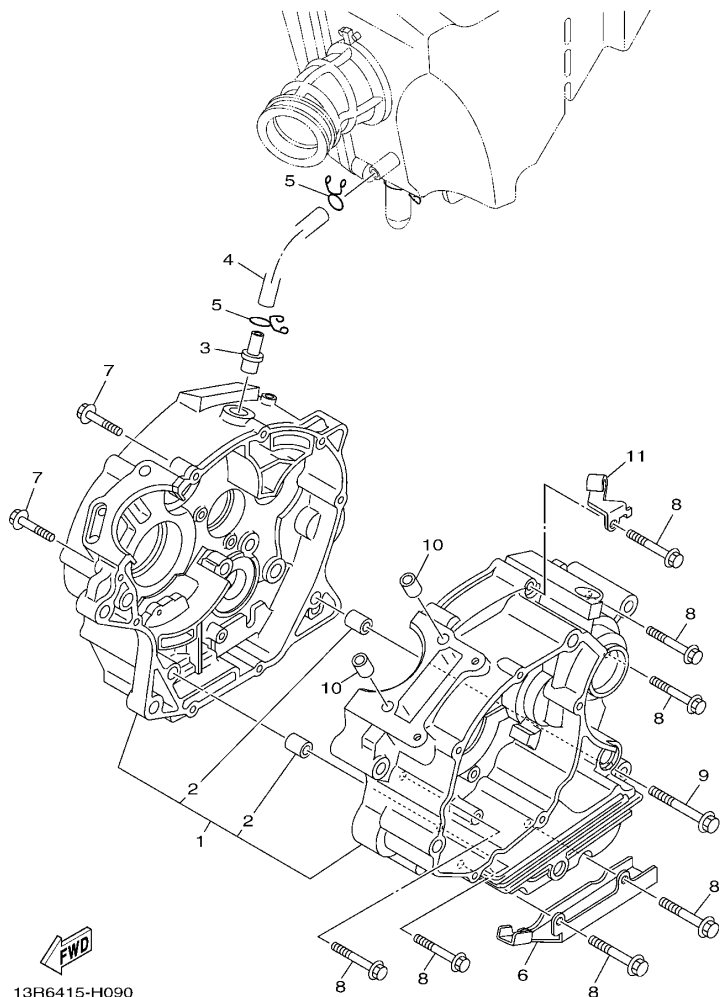

FIG. 8 排气装置

EXHAUST

参照 号码	零件号码 PART NO.	零件名称 DESCRIPTION	1BK5	1BK6	1BK7	1BK8	备注 REMARKS
1	1SF-E4710-01	消音器总成 1 MUFFLER ASSY 1	1	1	1	1	
2	4TU-F4741-00	.缓冲座 .PAD, SEAT	1	1	1	1	
3	1SF-E4758-01	.消声器保护 .PROTECTOR, SILENCER	1	1	1	1	
4	98980-06012	.螺钉 .SCREW, BIND	2	2	2	2	
5	90201-05803	.平垫圈 .WASHER, PLATE	2	2	2	2	
6	90201-05804	.平垫圈 .WASHER, PLATE	2	2	2	2	
7	5VL-E4613-00	排气管衬垫 GASKET, EXHAUST PIPE	1	1	1	1	
8	91312-06020	螺栓 BOLT	2	2	2	2	
9	95812-08020	凸缘螺栓 BOLT, FLANGE	1	1	1	1	
10	90201-08840	平垫圈 WASHER, PLATE	1	1	1	1	
11	3D9-E113F-00	板 3 PLATE 3	1	1	1	1	
12	5VL-E4815-00	衬垫 GASKET	1	1	1	1	
13	91312-06016	螺栓 BOLT	2	2	2	2	
14	3D9-E4881-00	弯曲软管 1 HOSE, BEND 1	1	1	1	1	
15	90467-16807	卡环 CLIP	1	1	1	1	
16	90467-19801	卡环 CLIP	1	1	1	1	
17	18C-E4873-00	管 3 PIPE 3	1	1	1	1	
18	90467-18806	卡环 CLIP	1	1	1	1	
19	1BK-E4882-00	弯曲软管 2 HOSE, BEND 2	1	1	1	1	
20	13R-E4803-00	二次进气系统 AIR INDUCTION SYSTEM ASSY	1	1	1	1	
21	92012-06012	螺钉 BOLT, BUTTON HEAD	2	2	2	2	
22	3D9-E4883-00	弯曲软管 3 HOSE, BEND 3	1	1	1	1	
23	90467-14802	卡环 CLIP	3	3	3	3	
24	90480-20M05	橡胶垫 GROMMET	1	1	1	1	



13R6415-H090

FIG. 9 曲轴箱

CRANKCASE

参照 号码	零件号码 PART NO.	零件名称 DESCRIPTION	1BK5	1BK6	1BK7	1BK8	备注 REMARKS
1	1SF-W1510-00	曲轴箱组合 CRANKCASE ASSY	1	1	1	1	
2	99530-10114	.定位销 .PIN, DOWEL	2	2	2	2	
3	4FP-E1167-00	通气管 2 PIPE, BREATHER 2	1	1	1	1	
4	5VL-E1166-00	通气管 1 PIPE, BREATHER 1	1	1	1	1	
5	90467-12828	卡环 CLIP	2	2	2	2	
6	90462-16801	线夹 CLAMP	1	1	1	1	
7	95022-06030	凸缘螺栓 BOLT, FLANGE	2	2	2	2	
8	95022-06045	凸缘螺栓 BOLT, FLANGE	7	7	7	7	
9	95022-06055	凸缘螺栓 BOLT, FLANGE	1	1	1	1	
10	99530-10114	定位销 PIN, DOWEL	2	2	2	2	
11	5VL-E5441-01	离合器钢索支架 HOLDER, CLUTCH CABLE	1	1	1	1	

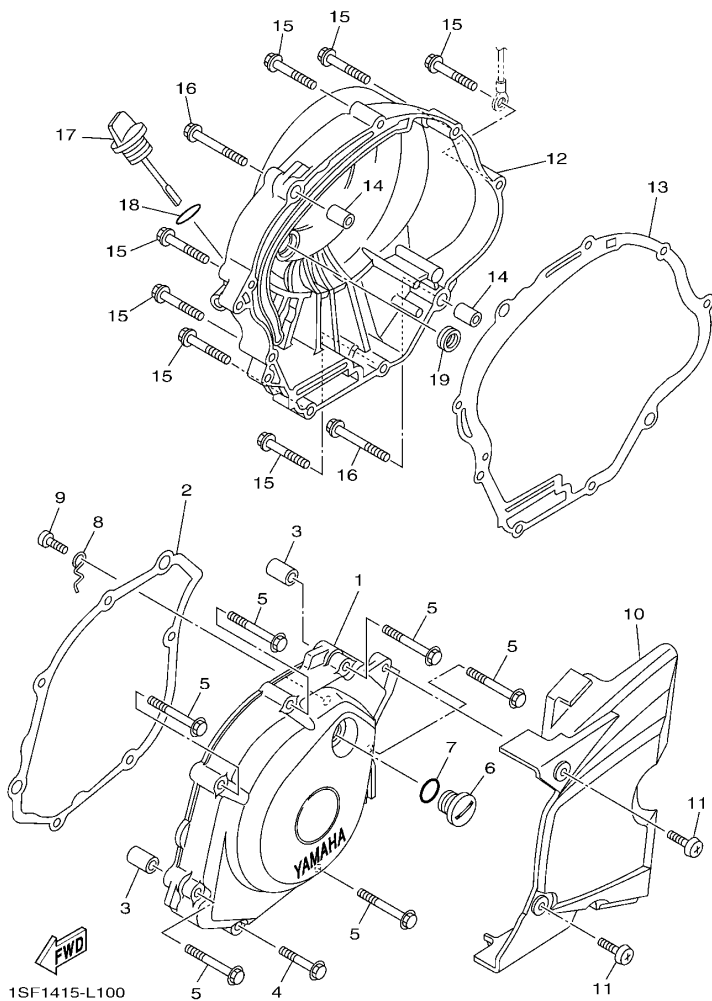

FIG. 10 曲轴箱盖 1

CRANKCASE COVER 1

参照 号码	零件号码 PART NO.	零件名称 DESCRIPTION	1BK5	1BK6	1BK7	1BK8	备注 REMARKS
1	1SF-E5411-00	曲轴箱盖 1 COVER, CRANKCASE 1	1	1	1	1	
2	5VL-E5451-10	曲轴箱盖衬垫 1 GASKET, CRANKCASE COVER 1	1	1	1	1	
3	99530-10114	定位销 PIN, DOWEL	2	2	2	2	
4	95022-06035	凸缘螺栓 BOLT, FLANGE	1	1	1	1	
5	95022-06050	凸缘螺栓 BOLT, FLANGE	6	6	6	6	
6	90340-14810	螺塞 PLUG, STRAIGHT SCREW	1	1	1	1	
7	93210-14817	O型环 O-RING	1	1	1	1	
8	5VL-E5191-00	面板 PLATE	1	1	1	1	
9	98512-06010	十字螺钉 SCREW, PAN HEAD	1	1	1	1	
10	1BK-E5418-10	链条箱盖 COVER, CHAIN CASE	1	1	1	1	
11	98902-06016	十字槽盘头螺钉 SCREW, BIND	2	2	2	2	
12	1SF-E5421-00	曲轴箱盖 2 COVER, CRANKCASE 2	1	1	1	1	
13	5VL-E5461-10	曲轴箱盖衬垫 2 GASKET, CRANKCASE COVER 2	1	1	1	1	
14	99530-10114	定位销 PIN, DOWEL	2	2	2	2	
15	95022-06035	凸缘螺栓 BOLT, FLANGE	7	7	7	7	
16	95022-06045	凸缘螺栓 BOLT, FLANGE	2	2	2	2	
17	5VL-E5362-00	油标塞 PLUG, OIL LEVEL	1	1	1	1	
18	93210-19809	O型环 O-RING	1	1	1	1	
19	93101-10800	油封 OIL SEAL	1	1	1	1	

FIG. 11 起动离合器

STARTER CLUTCH

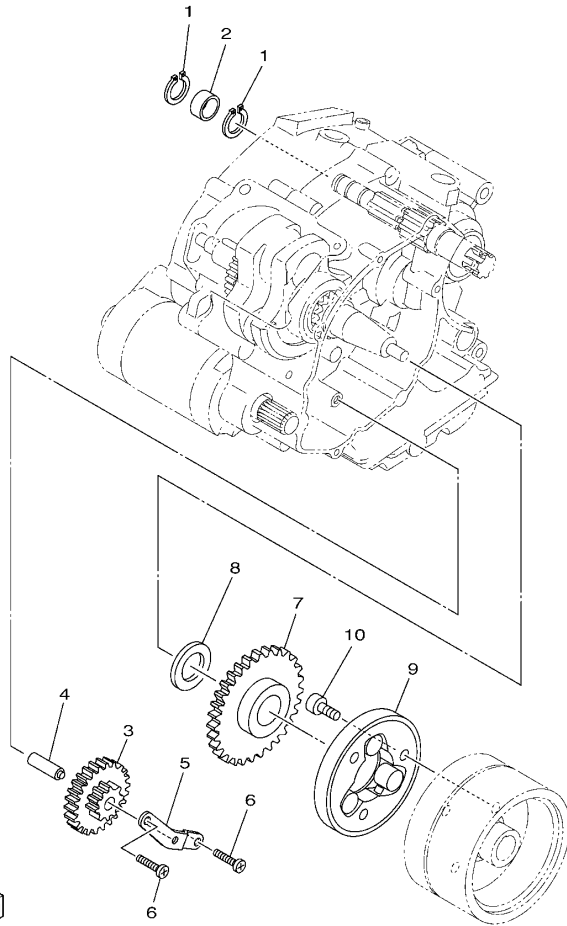

1SF1415-L110

参照 号码	零件号码 PART NO.	零件名称 DESCRIPTION	1BK5	1BK6	1BK7	1BK8	备注 REMARKS
1	90387-15803	轴套 COLLAR	1	1	1	1	
2	99009-15400	卡环 CIRCLIP	2	2	2	2	
3	5VL-E5512-00	惰齿轮 1 GEAR, IDLER 1	1	1	1	1	
4	5VL-E5521-00	轴 1 SHAFT 1	1	1	1	1	
5	5VL-E5532-00	惰齿轮面板 PLATE, IDLE GEAR	1	1	1	1	
6	98512-06012	十字螺钉 SCREW, PAN HEAD	2	2	2	2	
7	5VL-E5517-00	惰齿轮 2 GEAR, IDLER 2	1	1	1	1	
8	90201-258D7	平垫圈 WASHER, PLATE	1	1	1	1	
9	1BK-E5580-00	起动离合器外部组合 STARTER CLUTCH OUTER ASSY	1	1	1	1	
10	91312-08016	螺栓 BOLT	3	3	3	3	

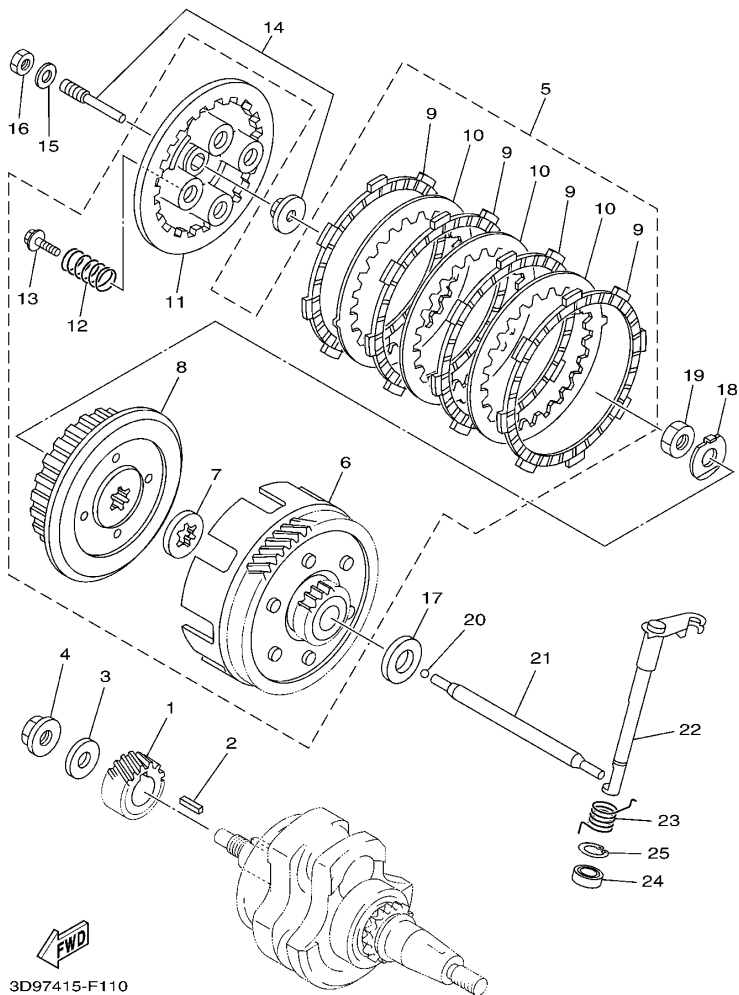

3D97415-F110

FIG. 12 离合器

CLUTCH

参照 号码	零件号码 PART NO.	零件名称 DESCRIPTION	1BK5	1BK6	1BK7	1BK8	备注 REMARKS
1	1JP-E6111-00	初级驱动齿轮 GEAR, PRIMARY DRIVE	1	1	1	1	
2	90282-05001	平键 KEY, STRAIGHT (5MMX16MM)	1	1	1	1	
3	90201-122H1	平垫圈 WASHER, PLATE	1	1	1	1	
4	90179-12813	螺母 NUT	1	1	1	1	
5	1JP-E6300-10	离合器总成 CLUTCH ASSY	1	1	1	1	
6	1JP-E6150-10	.从动齿轮组合 .PRIMARY DRIVEN GEAR COMP.	1	1	1	1	
7	1JP-E6154-00	.推板 1 .PLATE, THRUST 1	1	1	1	1	
8	1JP-E6371-00	.离合器轮毂 .BOSS, CLUTCH	1	1	1	1	
9	1JP-E6321-00	.摩擦片 .PLATE, FRICTION	4	4	4	4	
10	1JP-E6324-00	.离合器片 1 .PLATE, CLUTCH 1	3	3	3	3	
11	1JP-E6351-00	.压板 1 .PLATE, PRESSURE 1	1	1	1	1	
12	1JP-E6333-00	.离合器弹簧 1 .SPRING, CLUTCH 1	4	4	4	4	
13	1JP-E6337-00	.弹簧螺钉 .SCREW, SPRING	4	4	4	4	
14	5VL-Y1635-10	推杆组合 PUSH LEVER COMP.	1	1	1	1	
15	92902-06200	垫圈 WASHER	1	1	1	1	
16	95302-06600	螺母 NUT	1	1	1	1	
17	5VL-E6164-10	推板 2 PLATE, THRUST 2	1	1	1	1	
18	90215-12211	制动垫圈 WASHER, LOCK	1	1	1	1	
19	90170-12060	螺母 NUT	1	1	1	1	
20	93503-16824	钢球 BALL	1	1	1	1	
21	5VL-E6357-01	推杆 2 ROD, PUSH 2	1	1	1	1	
22	5VL-E6381-02	推杆组合 PUSH LEVER COMP.	1	1	1	1	
23	90508-16800	扭簧 SPRING, TORSION	1	1	1	1	
24	93102-12812	油封 OIL SEAL	1	1	1	1	
25	99009-20500	卡环 CIRCLIP	1	1	1	1	

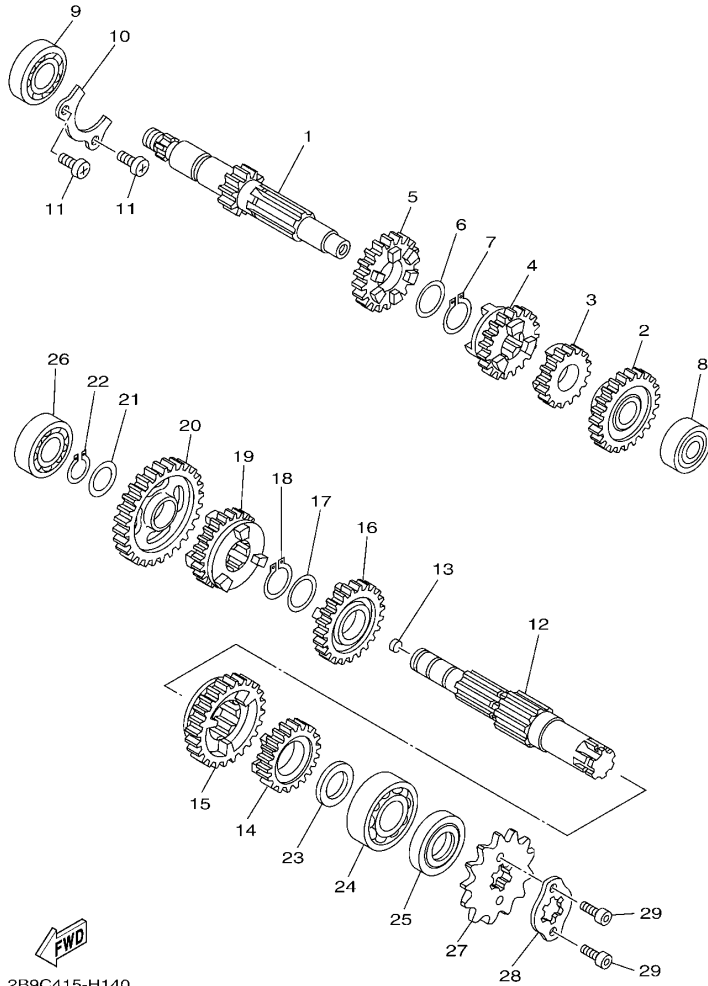

2B9C415-H140

FIG. 13 传动

TRANSMISSION

参照 号码	零件号码 PART NO.	零件名称 DESCRIPTION	1BK5	1BK6	1BK7	1BK8	备注 REMARKS
1	5VL-E7411-00	主轮轴 AXLE, MAIN (14T)	1	1	1	1	
2	5VL-E7151-00	五档主动齿轮 GEAR, 5TH PINION (24T)	1	1	1	1	
3	5VL-E7121-00	二档主动齿轮 GEAR, 2ND PINION (18T)	1	1	1	1	
4	5VL-E7131-00	三档主动齿轮 GEAR, 3RD PINION (19T)	1	1	1	1	
5	5VL-E7141-00	四档主动齿轮 GEAR, 4TH PINION (22T)	1	1	1	1	
6	90201-20266	平垫圈 WASHER, PLATE (T=1.0)	1	1	1	1	
7	93410-20809	卡环 CIRCLIP	1	1	1	1	
8	93306-201YD	轴承 BEARING	1	1	1	1	
9	93306-203YT	轴承 BEARING	1	1	1	1	
10	5VL-E7471-00	盖板 PLATE, COVER	1	1	1	1	
11	98512-06012	十字螺钉 SCREW, PAN HEAD	2	2	2	2	
12	5VL-E7421-00	驱动轴 AXLE, DRIVE	1	1	1	1	
13	90331-07031	密封塞 PLUG	1	1	1	1	
14	5VL-E7251-00	五档从动齿轮 GEAR, 5TH WHEEL (21T)	1	1	1	1	
15	5VL-E7221-00	二档从动齿轮 GEAR, 2ND WHEEL (32T)	1	1	1	1	
16	5VL-E7231-00	三档从动齿轮 GEAR, 3RD WHEEL (25T)	1	1	1	1	
17	90201-20266	平垫圈 WASHER, PLATE (T=1.0)	1	1	1	1	
18	93410-20809	卡环 CIRCLIP	1	1	1	1	
19	5VL-E7241-00	四档从动齿轮 GEAR, 4TH WHEEL (23T)	1	1	1	1	
20	5VL-E7211-00	一档从动齿轮 GEAR, 1ST WHEEL (37T)	1	1	1	1	
21	90201-15700	平垫圈 WASHER, PLATE	1	1	1	1	
22	99009-15400	卡环 CIRCLIP	1	1	1	1	
23	90201-20272	平垫圈 WASHER, PLATE	1	1	1	1	
24	93306-204XD	轴承 BEARING	1	1	1	1	
25	93102-20812	油封 OIL SEAL	1	1	1	1	
26	93306-252XH	轴承 BEARING	1	1	1	1	
27	93822-14813	驱动链轮 SPROCKET, DRIVE (14T)	1	1	1	1	

FIG. 13 传动

TRANSMISSION

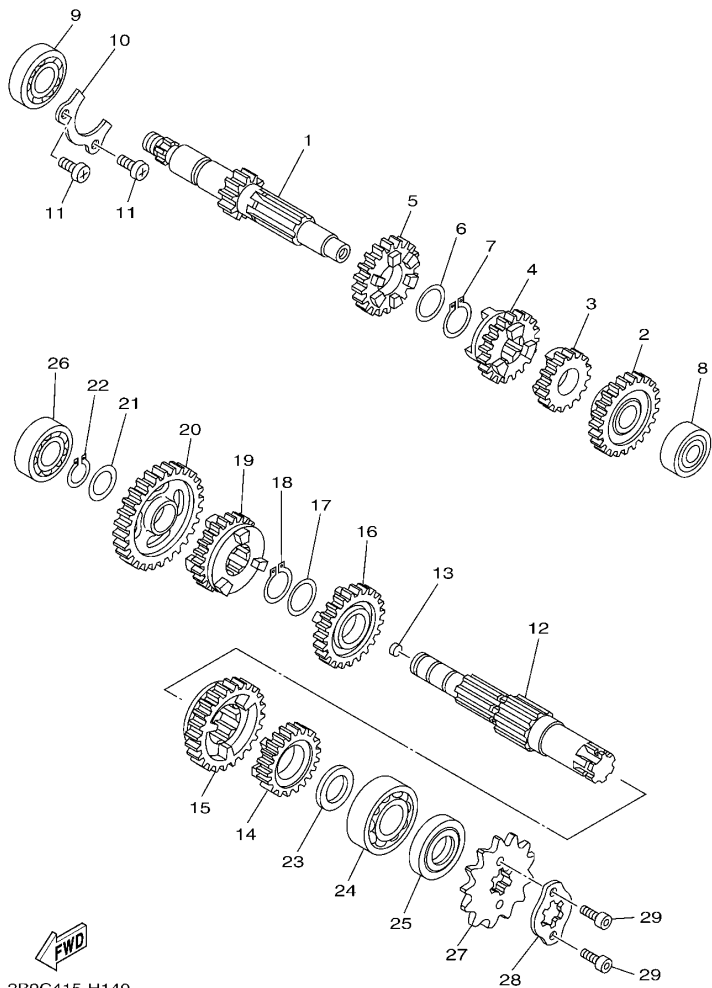

2B9C415-H140

参照 号码	零件号码 PART NO.	零件名称 DESCRIPTION	1BK5	1BK6	1BK7	1BK8	备注 REMARKS
28	3D9-E7456-01	驱动链轮挡圈 HOLDER, SPROCKET	1	1	1	1	
29	91312-05010	螺栓 BOLT	2	2	2	2	

FIG. 14 换挡凸轮·拨叉

SHIFT CAM & FORK

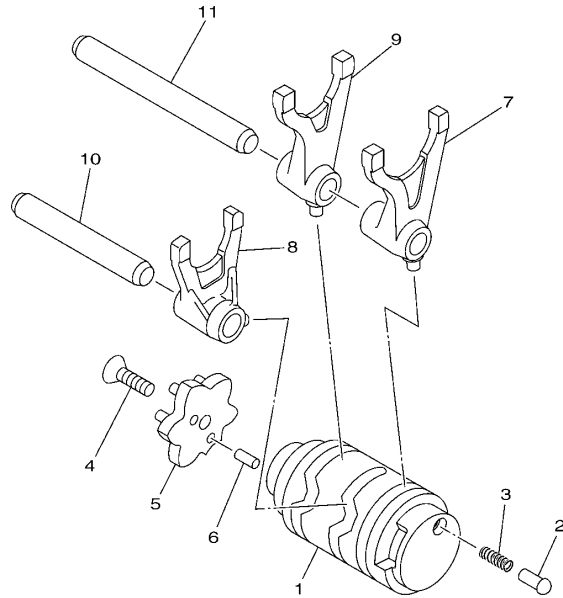

参照 号码	零件号码 PART NO.	零件名称 DESCRIPTION	1BK5	1BK6	1BK7	1BK8	备注 REMARKS
1	1SF-E8541-00	换挡凸轮轴 CAM, SHIFT	1	1	1	1	
2	1JD-E8542-00	端子 POINT, NEUTRAL	1	1	1	1	
3	90501-06805	压簧 SPRING, COMPRESSION	1	1	1	1	
4	90151-06818	沉头螺钉 SCREW, COUNTERSUNK	1	1	1	1	
5	1BK-E8185-00	星形轮 SEGMENT	1	1	1	1	
6	93604-10837	定位销 PIN, DOWEL	2	2	2	2	
7	2D0-E8511-00	换挡拨叉 1 FORK, SHIFT 1	1	1	1	1	
8	2D0-E8512-00	换挡拨叉 2 FORK, SHIFT 2	1	1	1	1	
9	2D0-E8513-00	换挡拨叉 3 FORK, SHIFT 3	1	1	1	1	
10	5VL-E8531-00	拨叉导杆 1 BAR, SHIFT FORK GUIDE 1	1	1	1	1	
11	5VL-E8535-00	拨叉导杆 2 BAR, SHIFT FORK GUIDE 2	1	1	1	1	

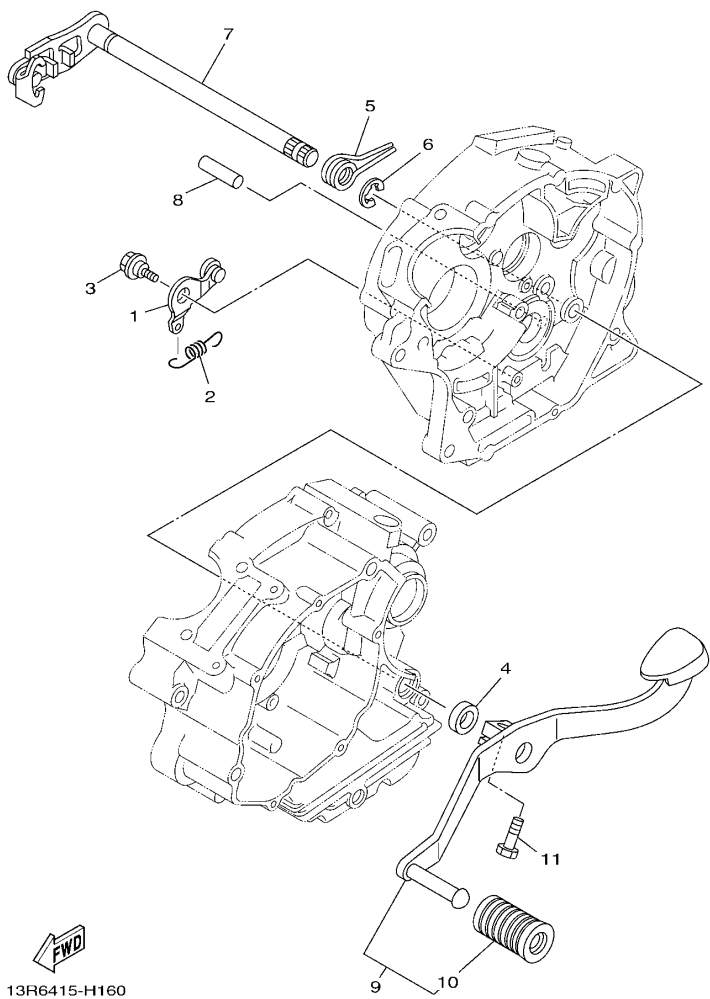

13R6415-H160

FIG. 15 变速杆

SHIFT SHAFT

参照 号码	零件号码 PART NO.	零件名称 DESCRIPTION	1BK5	1BK6	1BK7	1BK8	备注 REMARKS
1	5VL-E8140-00	限位杆组合 STOPPER LEVER ASSY	1	1	1	1	
2	5VL-E8337-00	弹簧 SPRING	1	1	1	1	
3	4FP-E8177-00	限位杆螺栓 BOLT, STOPPER	1	1	1	1	
4	93101-12803	油封 OIL SEAL	1	1	1	1	
5	90508-32801	扭簧 SPRING, TORSION	1	1	1	1	
6	99002-10600	卡环 CLIP	1	1	1	1	
7	5VL-E8101-12	变速杆总成 SHIFT SHAFT ASSY	1	1	1	1	
8	93608-30839	定位销 PIN, DOWEL	1	1	1	1	
9	5VL-E8110-12	换挡踏板组合 SHIFT PEDAL ASSY	1	1	1	1	
10	1KL-E8113-00	换挡踏板套 COVER, SHIFT PEDAL	1	1	1	1	
11	97022-06020	螺栓 BOLT, HEXAGON	1	1	1	1	

FIG. 16 车架

FRAME

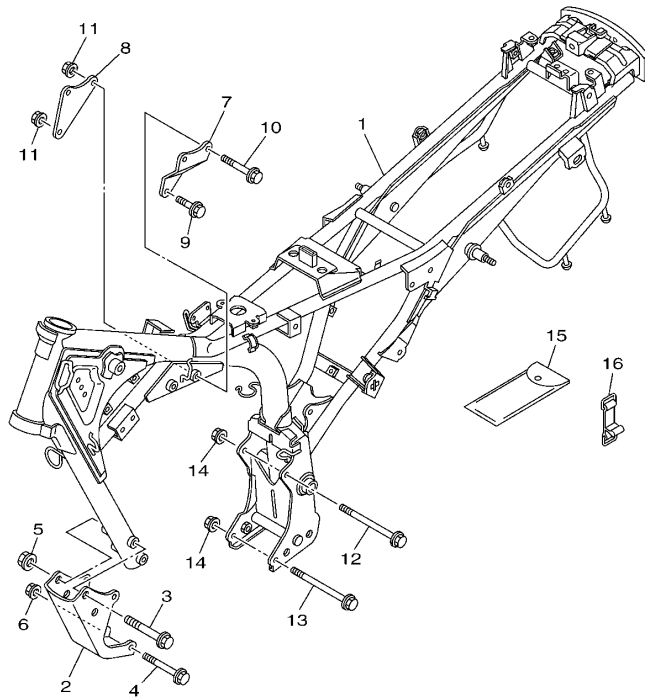

1BK5415-M160

参照 号码	零件号码 PART NO.	零件名称 DESCRIPTION	1BK5	1BK6	1BK7	1BK8	备注 REMARKS
1	1BK-F1110-11	车架组合 FRAME COMP.	1	1	1	1	
2	1BK-F1316-00	发动机支承 2 STAY, ENGINE 3	1	1	1	1	
3	95812-10080	凸缘螺栓 BOLT, FLANGE	2	2	2	2	
4	90105-08874	凸缘螺栓 BOLT, FLANGE	2	2	2	2	
5	90179-10807	螺母 NUT	2	2	2	2	
6	90179-08830	螺母 NUT	2	2	2	2	
7	5VL-F1317-00	发动机支承 3 STAY, ENGINE 3	1	1	1	1	
8	5VL-F1318-00	发动机支承 5 STAY, ENGINE 5	1	1	1	1	
9	90105-088E4	凸缘螺栓 BOLT, FLANGE	1	1	1	1	
10	90105-088E5	凸缘螺栓 BOLT, FLANGE	2	2	2	2	
11	90179-08830	螺母 NUT	3	3	3	3	
12	90105-08873	凸缘螺栓 BOLT, FLANGE	1	1	1	1	
13	90105-088E6	凸缘螺栓 BOLT, FLANGE	1	1	1	1	
14	90179-08830	螺母 NUT	2	2	2	2	
15	5VL-F8100-10	随车工具 TOOL KIT	1	1	1	1	
16	5VL-F811G-01	箍带 BAND	1	1	1	1	

FIG. 17 挡泥板

FENDER

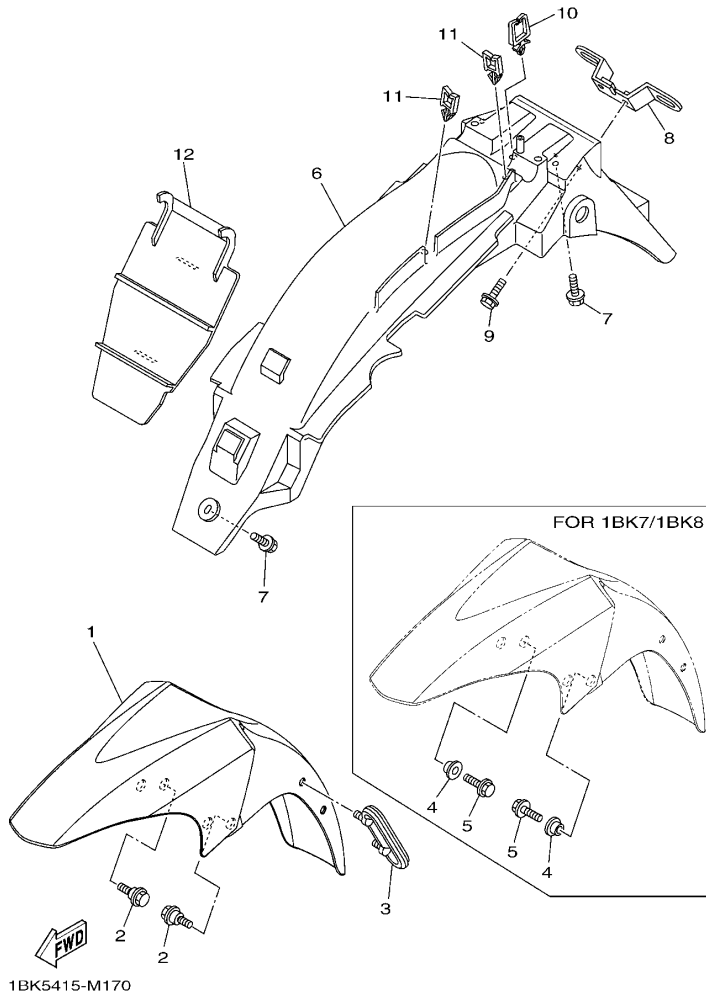

1BK5415-M170

参照 号码	零件号码 PART NO.	零件名称 DESCRIPTION	1BK5	1BK6	1BK7	1BK8	备注 REMARKS
1	1BK-Y2151-00-P0	前挡泥板 FRONT FENDER ASSY	1	1	1	1	UR 鸡尾酒鲜红色 7 车用 UR FOR VRC7
	1BK-Y2151-00-P1	前挡泥板 FRONT FENDER ASSY	1	1	1	1	UR 金属黑色车用 UR FOR SMX
	1BK-Y2151-00-P2	前挡泥板 FRONT FENDER ASSY	1	1	1	1	UR 浅紫深蓝色车用 UR FOR DPBMC
2	90109-06822	螺栓 BOLT	4	4			
3	5VL-F1518-01	钢索支架 HOLDER, CABLE	1	1	1	1	
4	90387-07818	轴套 COLLAR				4	4
5	95822-06016	凸缘螺栓 BOLT, FLANGE				4	4
6	1BK-F1611-00	后挡泥板 FENDER, REAR	1	1	1	1	
7	90119-06869	带垫螺栓 BOLT, WITH WASHER	3	3	3	3	
8	4GU-F1685-00	车牌托架 BRACKET, LICENSE	1	1	1	1	
9	90119-06811	带垫螺栓 BOLT, WITH WASHER	2	2	2	2	
10	90464-12803	线夹 CLAMP	1	1	1	1	
11	90464-16804	线夹 CLAMP	2	2	2	2	
12	5VL-F1621-00	挡板 FLAP	1	1	1	1	

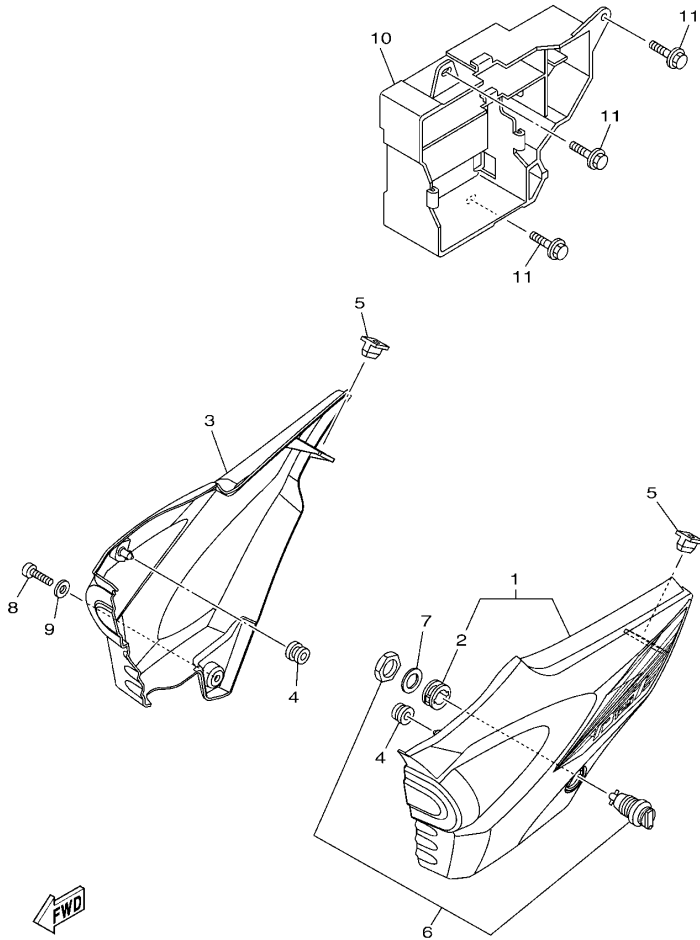

1BK5415-M180

FIG. 18 侧盖

SIDE COVER

参照 号码	零件号码 PART NO.	零件名称 DESCRIPTION	1BK5	1BK6	1BK7	1BK8	备注 REMARKS
1	1BK-Y2171-01-P0	侧盖 1 COVER, SIDE 1	1	1	1	1	UR 鸡尾酒鲜红色 7 车用 UR FOR VRC7
	1BK-Y2171-02-P0	侧盖 1 COVER, SIDE 1	1	1	1	1	UR 金属黑色车用 UR FOR SMX
	1BK-Y2171-03-P0	侧盖 1 COVER, SIDE 1	1	1	1	1	UR 浅紫深蓝色车用 UR FOR DPBMC
2	90480-24186	橡胶垫 GROMMET	1	1	1	1	
3	1BK-Y2172-01-P0	侧盖 2 COVER, SIDE 2	1	1	1	1	UR 鸡尾酒鲜红色 7 车用 UR FOR VRC7
	1BK-Y2172-02-P0	侧盖 2 COVER, SIDE 2	1	1	1	1	UR 金属黑色车用 UR FOR SMX
	1BK-Y2172-03-P0	侧盖 2 COVER, SIDE 2	1	1	1	1	UR 浅紫深蓝色车用 UR FOR DPBMC
4	90480-13837	橡胶垫 GROMMET	2	2	2	2	
5	5VL-F1778-00	定位减震器 1 DAMPER, LOCATING 1	2	2	2	2	
6	2D0-F1780-01	锁紧装置组合 LOCK ASSY	1	1			
	5VL-F1780-01	锁紧装置组合 LOCK ASSY				1	1
7	90201-228F6	平垫圈 WASHER, PLATE	1	1	1	1	
8	98902-06020	十字槽盘头螺钉 SCREW, BIND	1	1	1	1	
9	90201-06850	平垫圈 WASHER, PLATE	1	1	1	1	
10	5VL-F177G-00	蓄电池盒 BOX, BATTERY	1	1	1	1	
11	90119-06811	带垫螺栓 BOLT, WITH WASHER	3	3	3	3	

FIG. 19 后臂·悬挂

REAR ARM & SUSPENSION

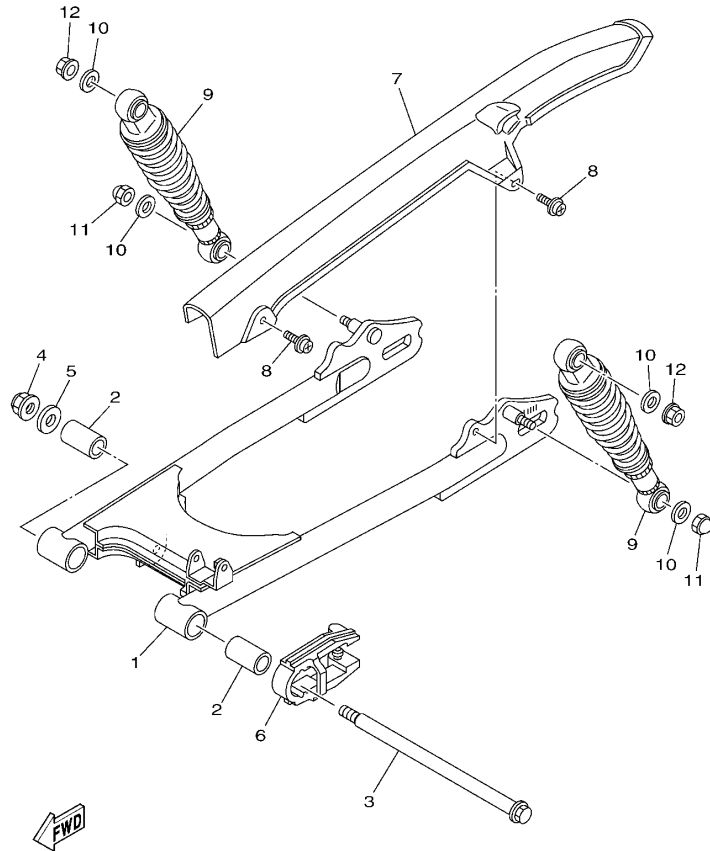

1BK5415-M190

参照 号码	零件号码 PART NO.	零件名称 DESCRIPTION	1BK5	1BK6	1BK7	1BK8	备注 REMARKS
1	1BK-F2110-00	后臂组合 REAR ARM COMP.	1	1	1	1	
2	90388-14800	减震垫 DAMPER	2	2	2	2	
3	5VL-F2141-01	后臂转轴 SHAFT, PIVOT	1	1	1	1	
4	95602-12200	自锁螺母 NUT, SELF-LOCKING	1	1	1	1	
5	90201-14809	平垫圈 WASHER, PLATE	1	1	1	1	
6	5VL-F2151-10	链条保护套 SEAL, GUARD	1	1	1	1	
7	5VL-F2311-00	链盒 CASE, CHAIN	1	1	1	1	
8	90159-06830	带垫螺钉 SCREW, WITH WASHER	2	2	2	2	
9	5VL-F2210-31	后减震器组合 SHOCK ABSORBER ASSY, REAR	2	2	2	2	
10	90201-108C7	平垫圈 WASHER, PLATE	4	4	4	4	
11	90176-10810	盖型螺母 NUT, CROWN	2	2	2	2	
12	95702-10500	螺母 NUT, FLANGE	2	2	2	2	

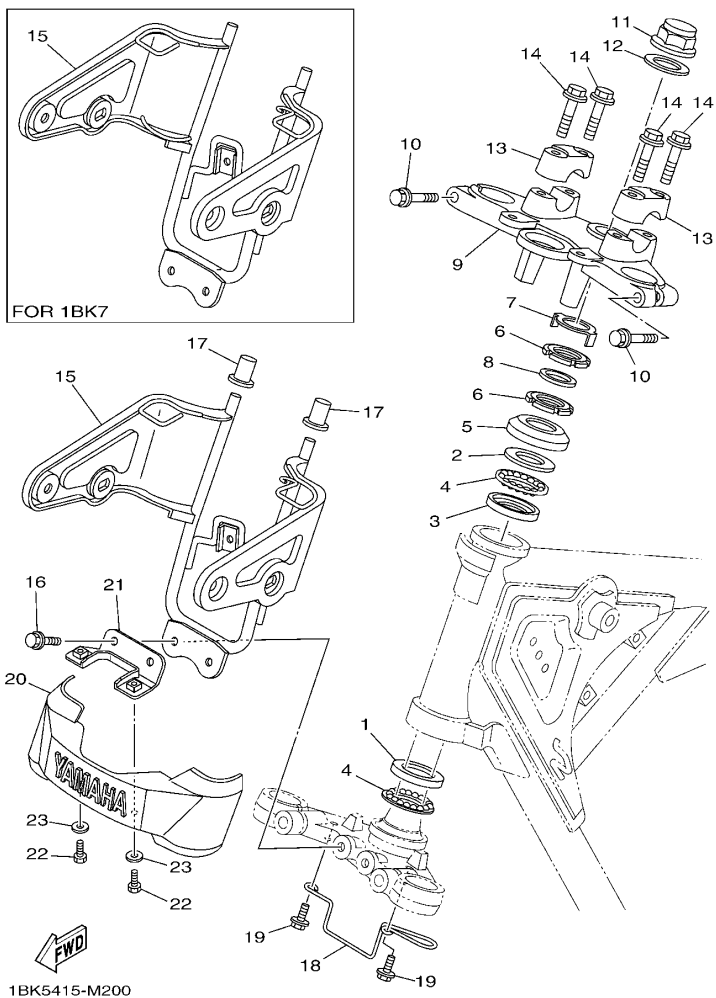

FIG. 20 操纵系统

STEERING

参照 号码	零件号码 PART NO.	零件名称 DESCRIPTION	1BK5	1BK6	1BK7	1BK8	备注 REMARKS
1	1KL-F3412-00	滚珠座圈 2 RACE, BALL 2	1	1	1		
2	4FP-F3411-00	滚珠座圈 1 RACE, BALL 1	1	1	1		
3	4FP-F3412-00	滚珠座圈 2 RACE, BALL 2	1	1	1		
4	5VL-F341E-00	保持架 RETAINER, BALL BEARING	2	2	2		
5	4GU-F3416-00	滚珠座圈盖 2 COVER, BALL RACE 2	1	1	1		
6	90179-25806	螺母 NUT	2	2	2		
7	5VL-F3418-01	专用垫圈 WASHER, SPECIAL	1	1	1		
8	90202-26142	平垫圈 WASHER, PLATE	1	1	1		
9	5VL-F3435-00-35	手把座 CROWN, HANDLE	1	1	1		银色 SL
10	95022-08040	凸缘螺栓 BOLT, FLANGE	2	2	2		
11	90176-22802	盖型螺母 NUT, CROWN	1	1	1		
12	5VL-F3165-01	垫圈 WASHER, FELT	1	1	1		
13	3S9-F3441-00	手把上夹持器 HOLDER, HANDLE UPPER	2	2	2		
14	95022-08035	凸缘螺栓 BOLT, FLANGE	4	4	4		
15	1BK-F3174-20	前照灯支承 STAY, HEADLIGHT	1	1			
	1BK-F3174-30	前照灯支承 STAY, HEADLIGHT				1	
16	95822-06016	凸缘螺栓 BOLT, FLANGE	2	2	2		
17	4FP-F317J-00	减震套 1 DAMPER 1	2	2	2		
18	5VL-F3389-01	钢索导框 GUIDE, CABLE	1	1	1		
19	95822-06012	凸缘螺栓 BOLT, FLANGE	2	2	2		
20	4FP-F3395-10	标牌 EMBLEM	1	1	1		
21	5VL-F334G-11	支承 1 BRACKET 1	1	1	1		
22	97002-05012	螺栓 BOLT	2	2	2		
23	90201-05802	平垫圈 WASHER, PLATE	2	2	2		

FIG. 21 操纵系统 2

STEERING 2

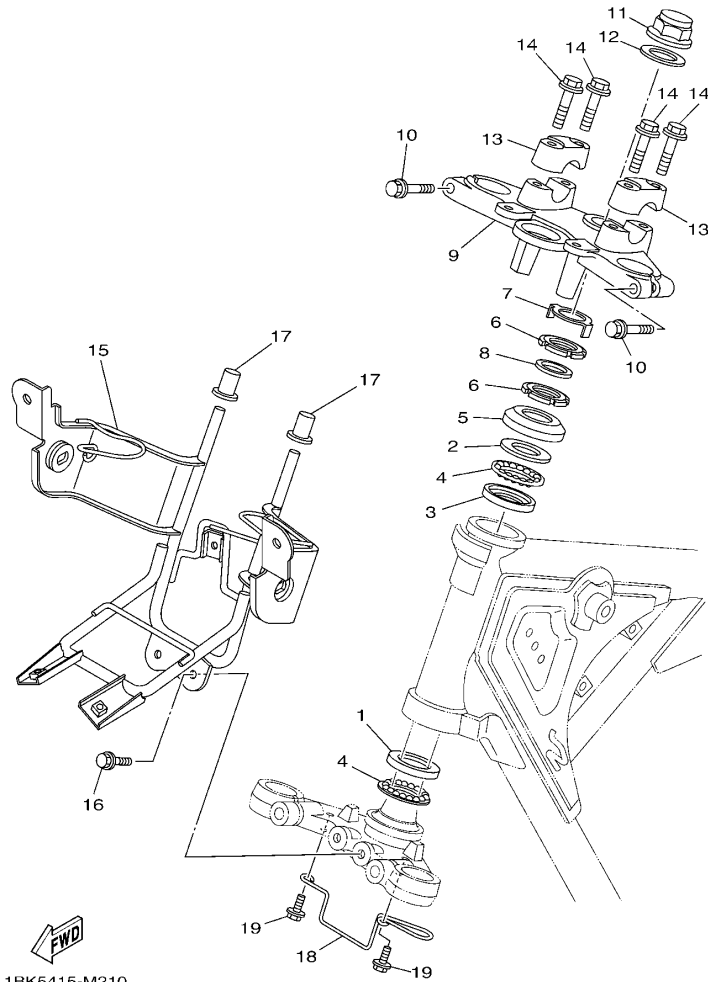

1BK5415-M210

参照 号码	零件号码 PART NO.	零件名称 DESCRIPTION	1BK5	1BK6	1BK7	1BK8	备注 REMARKS
1	1KL-F3412-00	滚珠座圈 2 RACE, BALL 2				1	
2	4FP-F3411-00	滚珠座圈 1 RACE, BALL 1				1	
3	4FP-F3412-00	滚珠座圈 2 RACE, BALL 2				1	
4	5VL-F341E-00	保持架 RETAINER, BALL BEARING				2	
5	4GU-F3416-00	滚珠座圈盖 2 COVER, BALL RACE 2				1	
6	90179-25806	螺母 NUT				2	
7	5VL-F3418-01	专用垫圈 WASHER, SPECIAL				1	
8	90202-26142	平垫圈 WASHER, PLATE				1	
9	5VL-F3435-00-35	手把座 CROWN, HANDLE				1	银色 SL
10	95022-08040	凸缘螺栓 BOLT, FLANGE				2	
11	90176-22802	盖型螺母 NUT, CROWN				1	
12	5VL-F3165-01	垫圈 WASHER, FELT				1	
13	3S9-F3441-00	手把上夹持器 HOLDER, HANDLE UPPER				2	
14	95022-08035	凸缘螺栓 BOLT, FLANGE				4	
15	1BK-F3174-40	前照灯支承 STAY, HEADLIGHT				1	
16	95822-06016	凸缘螺栓 BOLT, FLANGE				2	
17	4FP-F317J-00	减震套 1 DAMPER 1				2	
18	5VL-F3389-01	钢索导框 GUIDE, CABLE				1	
19	95822-06012	凸缘螺栓 BOLT, FLANGE				2	

FIG. 22 前叉(鼓刹)

FRONT FORK FOR DRUM BRAKE

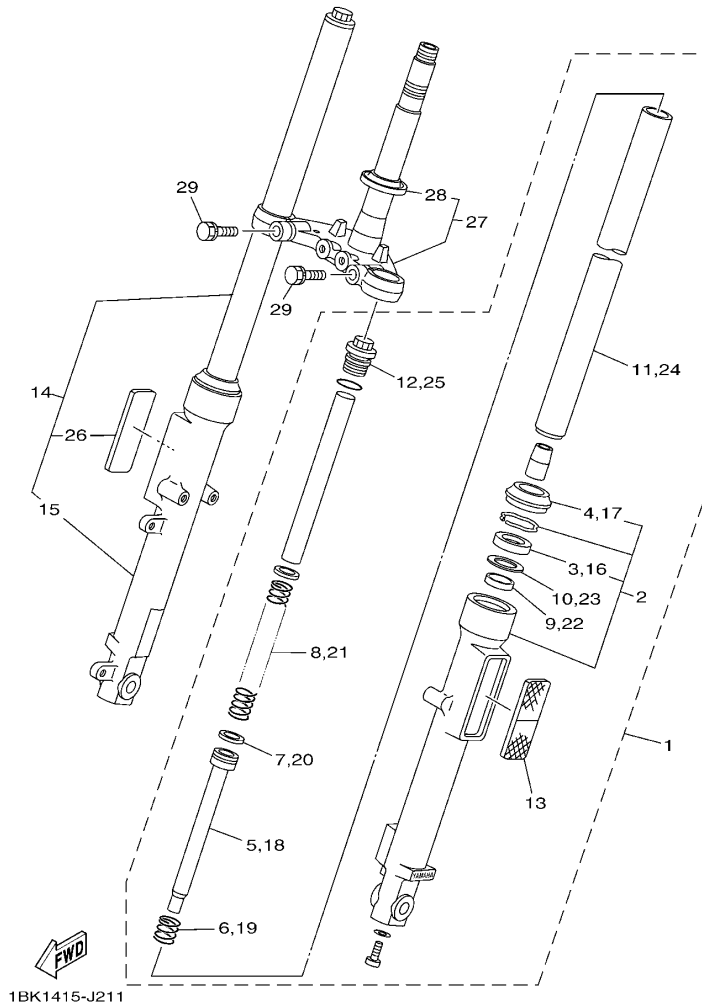

参照 号码	零件号码 PART NO.	零件名称 DESCRIPTION	1BK6	1BK6	1BK7	1BK8	备注 REMARKS
1	1BK-F3102-00	前叉组合(左边) FRONT FORK ASSY (L.H)	1	1			
2	5VL-F3106-50	.外管组件(左边) .OUTER TUBE COMP.	1	1			
3	1BK-F3145-00	.油封 .OIL SEAL	1	1			
4	4GU-F3144-10	.防尘罩 .SEAL, DUST	1	1			
5	5VL-F3170-10	.前叉气缸组合 .CYLINDER COMP., FRONT FORK	1	1			
6	2D0-F3152-00	.副弹簧 .SPRING, SUB	1	1			
7	2D0-F3157-00	.前叉活塞环 .RING, PISTON	1	1			
8	5VL-F3141-50	.前叉弹簧 .SPRING, FRONT FORK	1	1			
9	1BK-F3118-00	.衬套 .SPACER	1	1			
10	2D0-F3146-00	.油封垫圈 .WASHER, OIL SEAL	1	1			
11	1BK-F3110-00	.内管组件1 .INNER TUBE COMP.1	1	1			
12	1BK-F3111-00	.顶盖螺栓 .BOLT, CAP	1	1			
13	5VL-H5110-20	.反射镜组合 .REFLECTOR ASSY	1	1			
14	1BK-F3103-00	前叉组合(右边) FRONT FORK ASSY (R.H)	1	1			
15	1BK-F3107-00	.外管组件(右边) .OUTER TUBE COMP. (R.H)	1	1			
16	1BK-F3145-00	.油封 .OIL SEAL	1	1			
17	4GU-F3144-10	.防尘罩 .SEAL, DUST	1	1			
18	5VL-F3170-10	.前叉气缸组合 .CYLINDER COMP., FRONT FORK	1	1			
19	2D0-F3152-00	.副弹簧 .SPRING, SUB	1	1			
20	2D0-F3157-00	.前叉活塞环 .RING, PISTON	1	1			
21	5VL-F3141-50	.前叉弹簧 .SPRING, FRONT FORK	1	1			
22	1BK-F3118-00	.衬套 .SPACER	1	1			
23	2D0-F3146-00	.油封垫圈 .WASHER, OIL SEAL	1	1			
24	1BK-F3110-00	.内管组件1 .INNER TUBE COMP.1	1	1			
25	1BK-F3111-00	.顶盖螺栓 .BOLT, CAP	1	1			
26	5VL-H5110-20	.反射镜组合 .REFLECTOR ASSY	1	1			
27	5VL-F331X-10	下侧托架 BRACKET, UNDER	1	1			

FIG. 22 前叉(鼓刹)

FRONT FORK FOR DRUM BRAKE

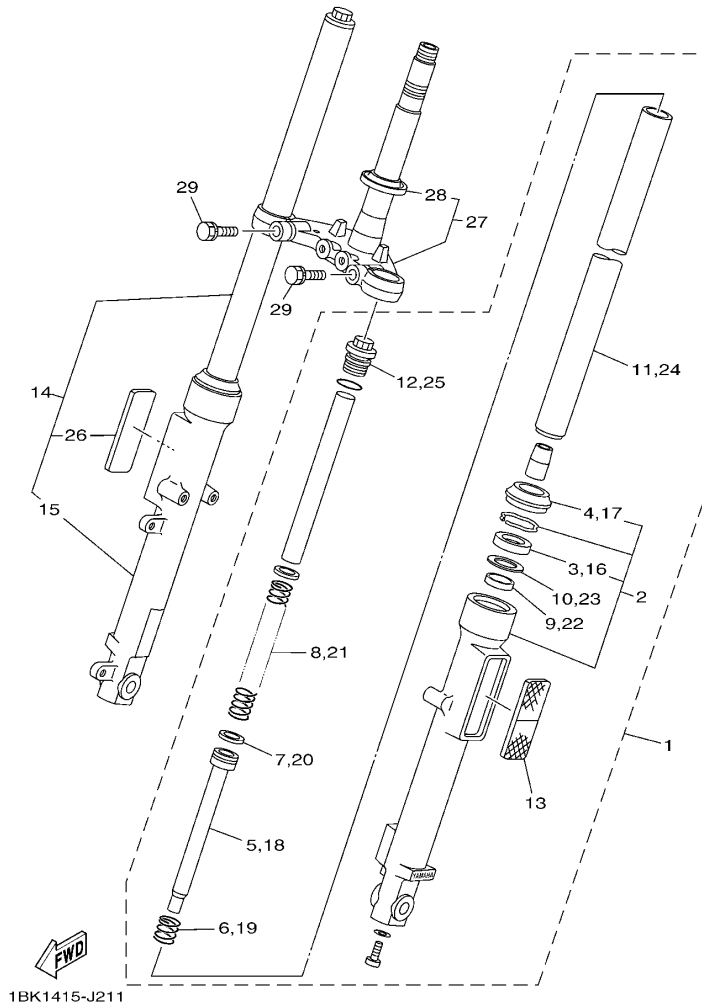

参照 号码	零件号码 PART NO.	零件名称 DESCRIPTION	1BK5	1BK6	1BK7	1BK8	备注 REMARKS
28	4FP-F3411-30	. 滚珠座圈 1 . RACE, BALL 1	1	1			
29	5VL-F3346-10	螺栓 1 BOLT 1	2	2			

FIG. 23 前叉(碟刹)

FRONT FORK FOR DISK BRAKE

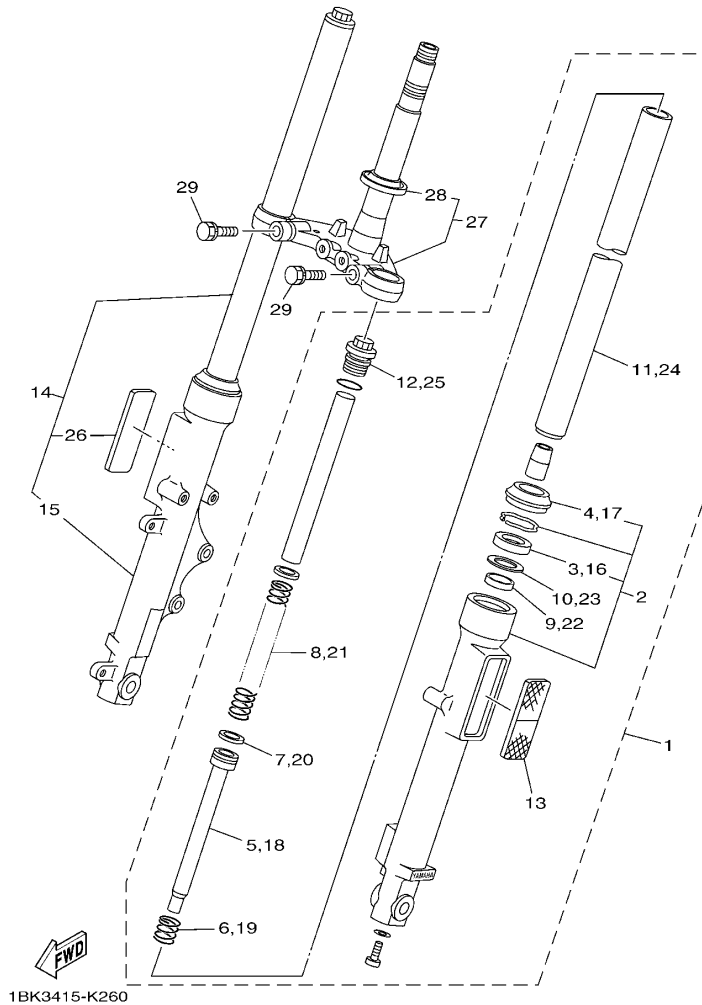

1BK3415-K260

参照 号码	零件号码 PART NO.	零件名称 DESCRIPTION	1BK5	1BK6	1BK7	1BK8	备注 REMARKS
1	1BK-F3102-10	前叉组合(左边) FRONT FORK ASSY (L.H)				1 1	
2	1BK-F3106-00	.外管组件(左边) .OUTER TUBE COMP.				1 1	
3	1BK-F3145-00	.油封 .OIL SEAL				1 1	
4	4GU-F3144-10	.防尘罩 .SEAL, DUST				1 1	
5	5VL-F3170-10	.前叉气缸组合 .CYLINDER COMP., FRONT FORK				1 1	
6	2D0-F3152-00	.副弹簧 .SPRING, SUB				1 1	
7	2D0-F3157-00	.前叉活塞环 .RING, PISTON				1 1	
8	5VL-F3141-50	.前叉弹簧 .SPRING, FRONT FORK				1 1	
9	1BK-F3118-00	.衬套 .SPACER				1 1	
10	2D0-F3146-00	.油封垫圈 .WASHER, OIL SEAL				1 1	
11	1BK-F3110-00	.内管组件1 .INNER TUBE COMP.1				1 1	
12	1BK-F3111-00	.顶盖螺栓 .BOLT, CAP				1 1	
13	5VL-H5110-20	.反射镜组合 .REFLECTOR ASSY				1 1	
14	1BK-F3103-10	前叉组合(右边) FRONT FORK ASSY (R.H)				1 1	
15	1BK-F3107-10	.外管组件(右边) .OUTER TUBE COMP. (R.H)				1 1	
16	1BK-F3145-00	.油封 .OIL SEAL				1 1	
17	4GU-F3144-10	.防尘罩 .SEAL, DUST				1 1	
18	5VL-F3170-10	.前叉气缸组合 .CYLINDER COMP., FRONT FORK				1 1	
19	2D0-F3152-00	.副弹簧 .SPRING, SUB				1 1	
20	2D0-F3157-00	.前叉活塞环 .RING, PISTON				1 1	
21	5VL-F3141-50	.前叉弹簧 .SPRING, FRONT FORK				1 1	
22	1BK-F3118-00	.衬套 .SPACER				1 1	
23	2D0-F3146-00	.油封垫圈 .WASHER, OIL SEAL				1 1	
24	1BK-F3110-00	.内管组件1 .INNER TUBE COMP.1				1 1	
25	1BK-F3111-00	.顶盖螺栓 .BOLT, CAP				1 1	
26	5VL-H5110-20	.反射镜组合 .REFLECTOR ASSY				1 1	
27	5VL-F331X-10	下侧托架 BRACKET, UNDER				1 1	

FIG. 23 前叉(碟刹)

FRONT FORK FOR DISK BRAKE

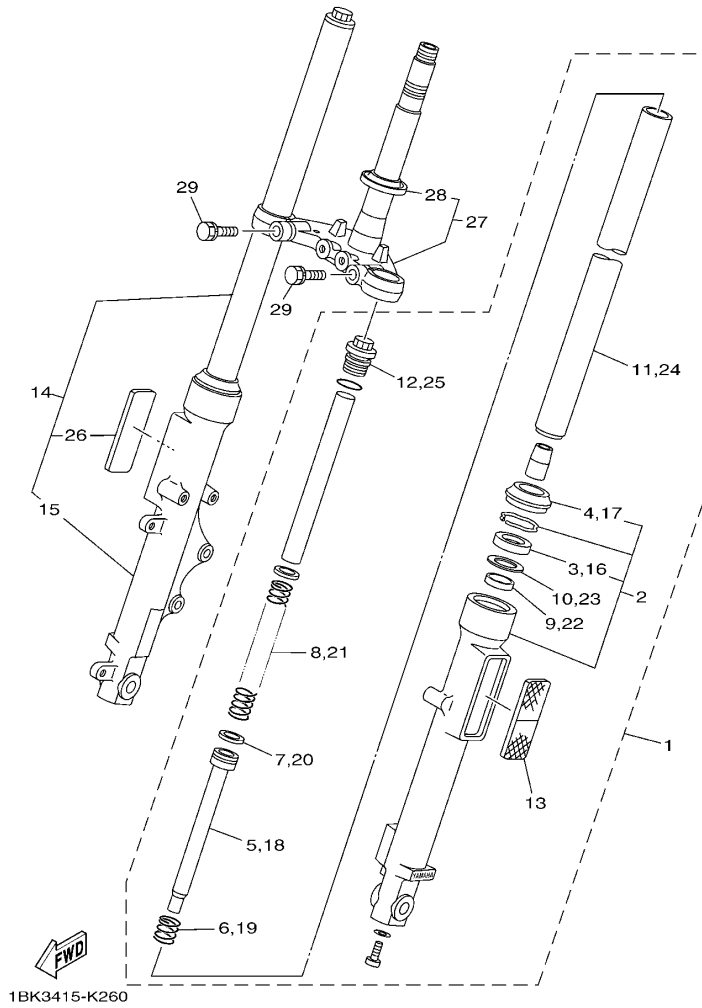

参照 号码	零件号码 PART NO.	零件名称 DESCRIPTION	1BK5	1BK6	1BK7	1BK8	备注 REMARKS
28	4FP-F3411-30	. 滚珠座圈 1 .RACE, BALL 1			1	1	
29	5VL-F3346-10	螺栓 1 BOLT 1			2	2	

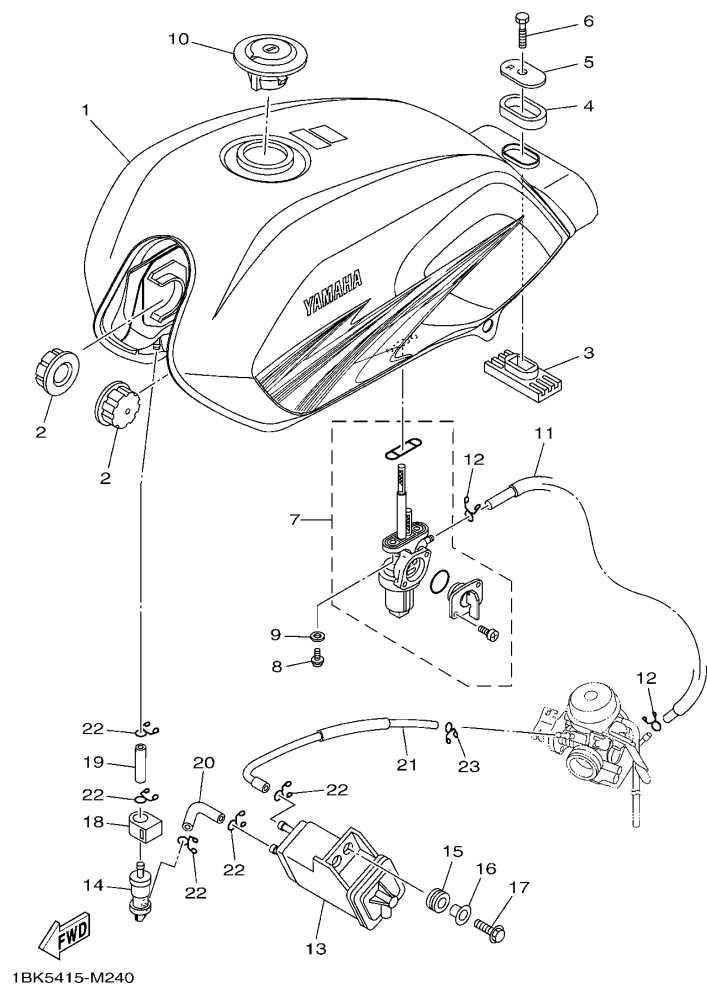

FIG. 24 油箱

FUEL TANK

参照 号码	零件号码 PART NO.	零件名称 DESCRIPTION	1BK5	1BK6	1BK7	1BK8	备注 REMARKS
1	1BK-W2411-01-P0	油箱组合 FUEL TANK ASSY	1	1	1	1	UR 鸡尾酒鲜红色 7 车用 UR FOR VRC7
	1BK-W2411-01-P1	油箱组合 FUEL TANK ASSY	1	1	1	1	UR 金属黑色车用 UR FOR SMX
	1BK-W2411-01-P2	油箱组合 FUEL TANK ASSY	1	1	1	1	UR 浅紫深蓝色车用 UR FOR DPBMC
2	4FP-F4181-00	定位减震器 1 DAMPER, LOCATING 1	2	2	2	2	
3	2D0-F4183-00	定位减震器 3 DAMPER, LOCATING 3	1	1	1	1	
4	4FP-F4183-00	定位减震器 3 DAMPER, LOCATING 3	1	1	1	1	
5	4FP-F4186-01	特制垫片 WASHER, SPECIAL	1	1	1	1	
6	2D0-F4176-01	螺栓 1 BOLT 1	1	1	1	1	
7	2D0-F4500-10	燃油开关组合 1 FUEL COCK ASSY 1	1	1	1	1	
8	90159-06820	带垫螺钉 SCREW, WITH WASHER	2	2	2	2	
9	90430-05800	衬垫 GASKET	2	2	2	2	
10	1BK-F4610-00	油箱盖总成 CAP ASSY	1	1			
	18C-F4610-01	油箱盖总成 CAP ASSY			1	1	
11	2D0-F4311-00	燃油管 1 PIPE, FUEL 1	1	1	1	1	
12	90467-09854	卡环 CLIP	2	2	2	2	
13	1BK-F4170-00	过滤缸总成 CANISTER ASSY	1	1	1	1	
14	1BK-F4180-01	滚动阀组合 ROLL OVER VALVE ASSY	1	1	1	1	
15	90480-13018	橡胶垫 GROMMET	2	2	2	2	
16	90387-06737	轴套 COLLAR	2	2	2	2	
17	95022-06016	凸缘螺栓 BOLT, FLANGE	2	2	2	2	
18	4S0-F4135-00	夹箍 1 CLAMP 1	1	1	1	1	
19	52C-F4312-00	管 2 PIPE 2	1	1	1	1	
20	52C-F4313-00	管 3 PIPE 3	1	1	1	1	
21	52C-F4314-00	管 4 PIPE 4	1	1	1	1	
22	90467-09006	卡环 CLIP	5	5	5	5	
23	90467-07029	卡环 CLIP	1	1	1	1	

FIG. 25 座位

SEAT

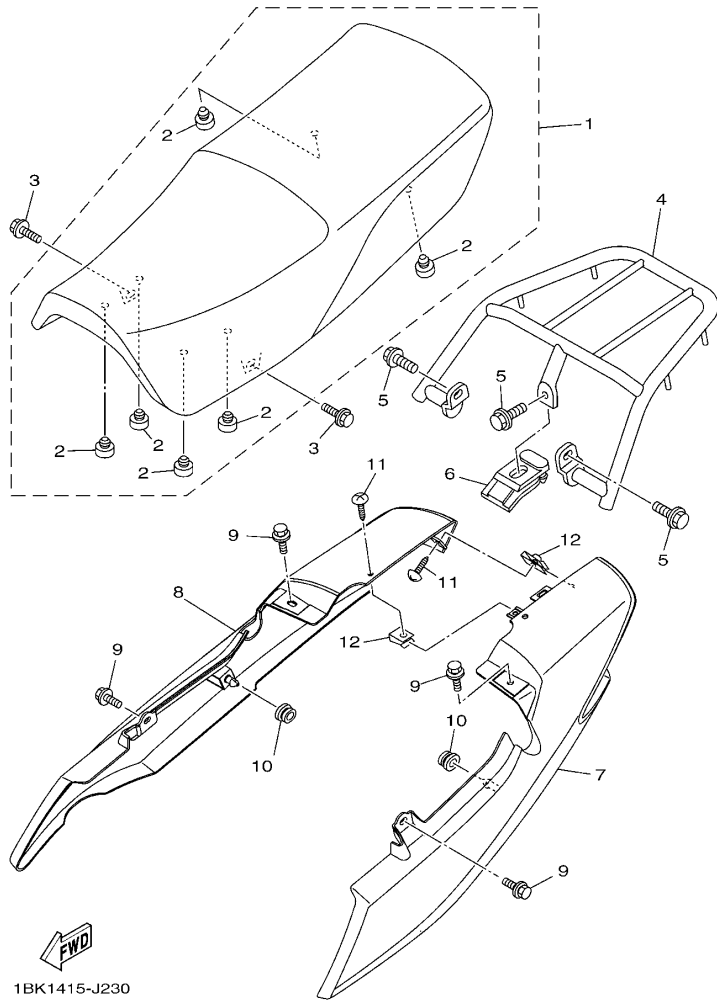

1BK1415-J230

参照 号码	零件号码 PART NO.	零件名称 DESCRIPTION	1BK5	1BK6	1BK7	1BK8	备注 REMARKS
1	2D0-F4730-11	双人座垫组合 DOUBLE SEAT ASSY	1	1	1	1	
2	4TU-F4741-00	.缓冲座 .PAD, SEAT	6	6	6	6	
3	90119-06869	带垫螺栓 BOLT, WITH WASHER	2	2	2	2	
4	1BK-F4840-00	载架组合 CARRIER ASSY	1	1	1	1	
5	95812-08016	凸缘螺栓 BOLT, FLANGE	3	3	3	3	
6	2D0-F4796-00	盖 COVER	1	1	1	1	
7	1BK-F471K-01-P0	尾罩 1 COVER, TAIL 1	1	1	1	1	UR 鸡尾酒鲜红色 7 车用 UR FOR VRC7 UR 金属黑色车用 UR FOR SMX
	1BK-F471K-01-P1	尾罩 1 COVER, TAIL 1	1	1	1	1	
	1BK-F471K-01-P2	尾罩 1 COVER, TAIL 1	1	1	1	1	
8	1BK-F472K-01-P0	尾罩 2 COVER, TAIL 2	1	1	1	1	UR 浅紫深蓝色车用 UR FOR DPBMC UR 鸡尾酒鲜红色 7 车用 UR FOR VRC7
	1BK-F472K-01-P1	尾罩 2 COVER, TAIL 2	1	1	1	1	
	1BK-F472K-01-P2	尾罩 2 COVER, TAIL 2	1	1	1	1	
9	90119-06869	带垫螺栓 BOLT, WITH WASHER	4	4	4	4	
10	90480-01868	橡胶垫 GROMMET	2	2	2	2	
11	97702-50012	自攻螺钉 SCREW, TAPPING	2	2	2	2	
12	90183-05807	弹性螺母 NUT, SPRING	2	2	2	2	

FIG. 26 前轮

FRONT WHEEL

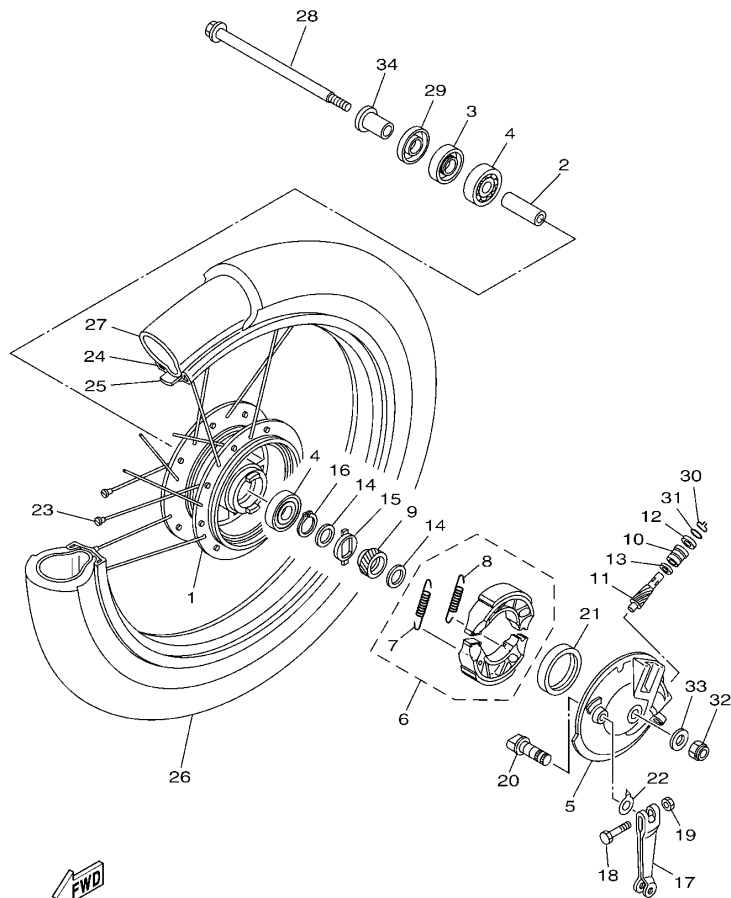

1BK1415-J240

参照 号码	零件号码 PART NO.	零件名称 DESCRIPTION	1BK5	1BK6	1BK7	1BK8	备注 REMARKS
1	5VL-F5111-00	前轮毂 HUB, FRONT	1				
2	90560-12828	衬套 SPACER	1				
3	93102-18804	油封 OIL SEAL	1				
4	93306-301XS	轴承 BEARING	2				
5	1BK-F5121-00-35	前制动盖 PLATE, BRAKE SHOE	1				银色 SL
6	5VL-W2533-21	制动蹄块总成 BRAKE SHOE SET	1				
7	90506-12801	拉簧 .SPRING, TENSION	1				
8	90506-15802	拉簧 .SPRING, TENSION	1				
9	1BK-F5135-00	主驱动齿轮 GEAR, DRIVE	1				
10	1KL-F5136-00	衬套 BUSH	1				
11	1KL-F5138-00	仪表齿轮 GEAR, METER	1				
12	93104-07800	油封 OIL SEAL	1				
13	90201-07836	平垫圈 WASHER, PLATE	1				
14	90201-20844	平垫圈 WASHER, PLATE	2				
15	1KL-F5149-01	速度表转动卡环 CLUTCH, METER	1				
16	93410-19831	卡环 CIRCLIP	1				
17	4FP-F5155-11	制动臂 1 LEVER, CAMSHAFT 1	1				
18	90101-06848	螺栓 BOLT	1				
19	95302-06600	螺母 NUT	1				
20	4GU-F5351-02	凸轮轴 CAMSHAFT	1				
21	93105-47808	油封 OIL SEAL	1				
22	4GU-F533A-01	指示片 PLATE, INDICATOR	1				
23	5VL-W5304-01	辐条套件 SPOKE SET, REAR	1				
24	94416-18803	轮辋 (1.60-18) RIM (1.60-18)	1				
25	94327-18800	轮辋撞带 (2.75-18) BAND, RIM (2.75-18)	1				CHENG SHIN
26	94127-18845	轮胎 (2.75-18) TIRE (2.75-18 329 6PR 48P TT)	1				WEIXING
27	94227-18818	内胎 (2.75-18) TUBE (2.75-18)	1				WEIXING

FIG. 26 前轮

FRONT WHEEL

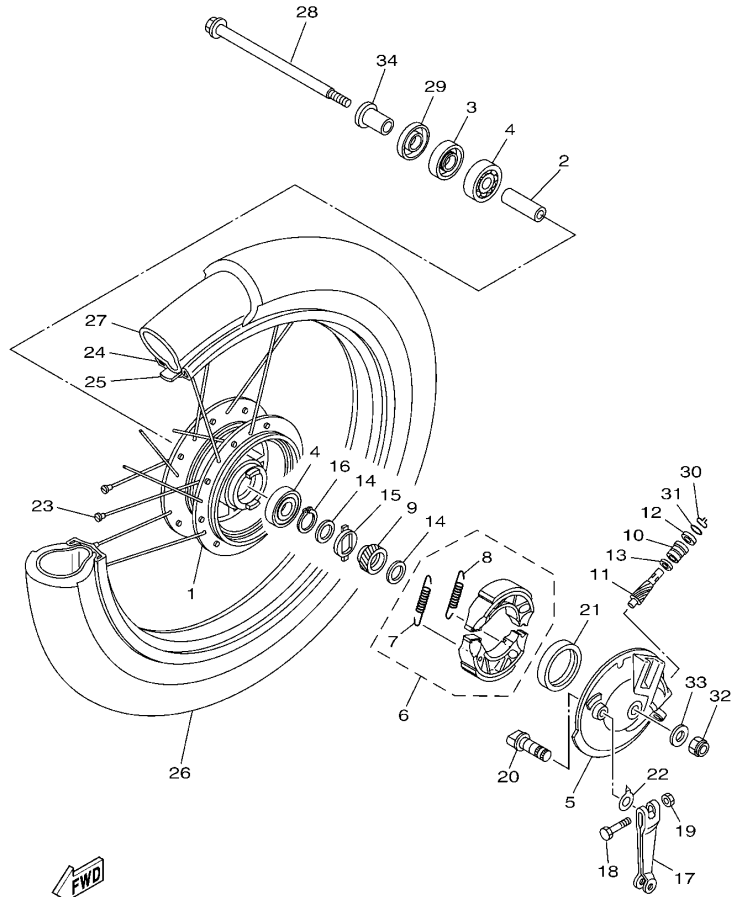

1BK1415-J240

参照 号码	零件号码 PART NO.	零件名称 DESCRIPTION	1BK5	1BK6	1BK7	1BK8	备注 REMARKS
28	5VL-F5181-01	前轮轮轴 AXLE, WHEEL	1				
29	1KL-F5118-00	轮毂防尘盖 COVER, HUB DUST	1				
30	1KL-F5137-01	止动环 RING, STOP	1				
31	93210-14818	O型环 O-RING	1				
32	90185-10807	自锁螺母 NUT, SELF-LOCKING	1				
33	90201-108C7	平垫圈 WASHER, PLATE	1				
34	90387-12840	轴套 COLLAR	1				

FIG. 27 前轮 2

FRONT WHEEL 2

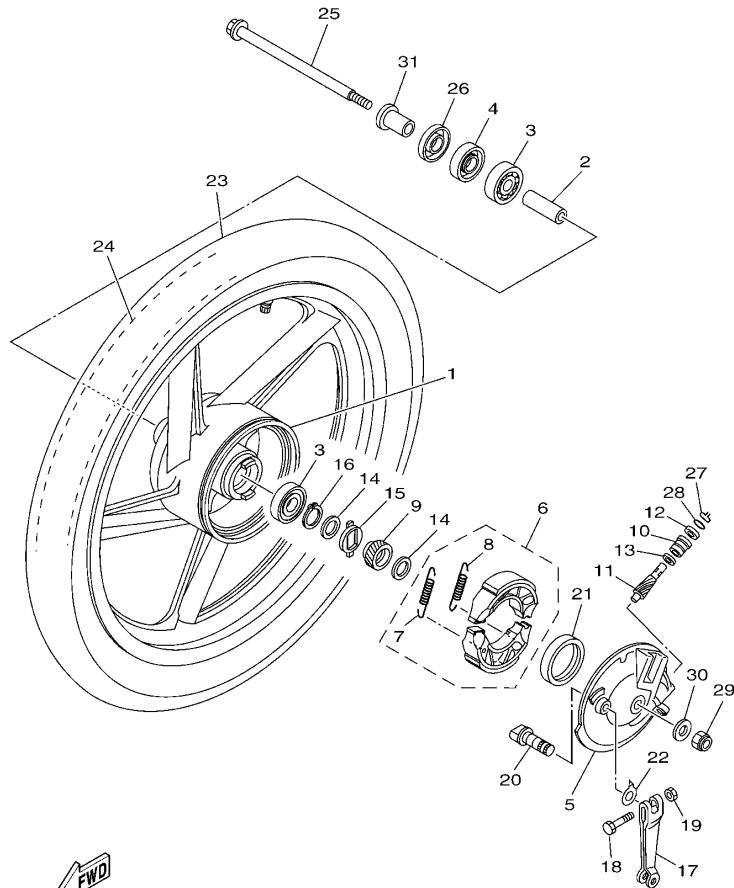

1BK5415-M270

参照 号码	零件号码 PART NO.	零件名称 DESCRIPTION	1BK5	1BK6	1BK7	1BK8	备注 REMARKS
1	1BK-F5168-00-33	前压铸轮 CAST WHEEL, FRONT			1		雅马哈黑色 YB
2	90560-12828	衬套 SPACER		1			
3	93306-301XS	轴承 BEARING			2		
4	93102-18804	油封 OIL SEAL		1			
5	1BK-F5121-00-33	前制动盖 PLATE, BRAKE SHOE		1			雅马哈黑色 YB
6	5VL-W2533-21	制动蹄块总成 BRAKE SHOE SET		1			
7	90506-12801	.拉簧 .SPRING, TENSION		1			
8	90506-15802	.拉簧 .SPRING, TENSION		1			
9	1BK-F5135-00	主驱动齿轮 GEAR, DRIVE		1			
10	1KL-F5136-00	衬套 BUSH		1			
11	1KL-F5138-00	仪表齿轮 GEAR, METER		1			
12	93104-07800	油封 OIL SEAL		1			
13	90201-07836	平垫圈 WASHER, PLATE		1			
14	90201-20844	平垫圈 WASHER, PLATE		2			
15	1KL-F5149-01	速度表转动卡环 CLUTCH, METER		1			
16	93410-19831	卡环 CIRCLIP		1			
17	4FP-F5155-11	制动臂 1 LEVER, CAMSHAFT 1		1			
18	90101-06848	螺栓 BOLT		1			
19	95302-06600	螺母 NUT		1			
20	4GU-F5351-02	凸轮轴 CAMSHAFT		1			
21	93105-47808	油封 OIL SEAL		1			
22	4GU-F533A-01	指示片 PLATE, INDICATOR		1			
23	94127-18845	轮胎 (2.75-18) TIRE (2.75-18 329 6PR 48P TT)		1			WEIXING
24	94227-18818	内胎 (2.75-18) TUBE (2.75-18)		1			WEIXING
25	5VL-F5181-01	前轮轮轴 AXLE, WHEEL		1			
26	1KL-F5118-00	轮毂防尘盖 COVER, HUB DUST		1			
27	1KL-F5137-01	止动环 RING, STOP		1			

FIG. 27 前轮 2

FRONT WHEEL 2

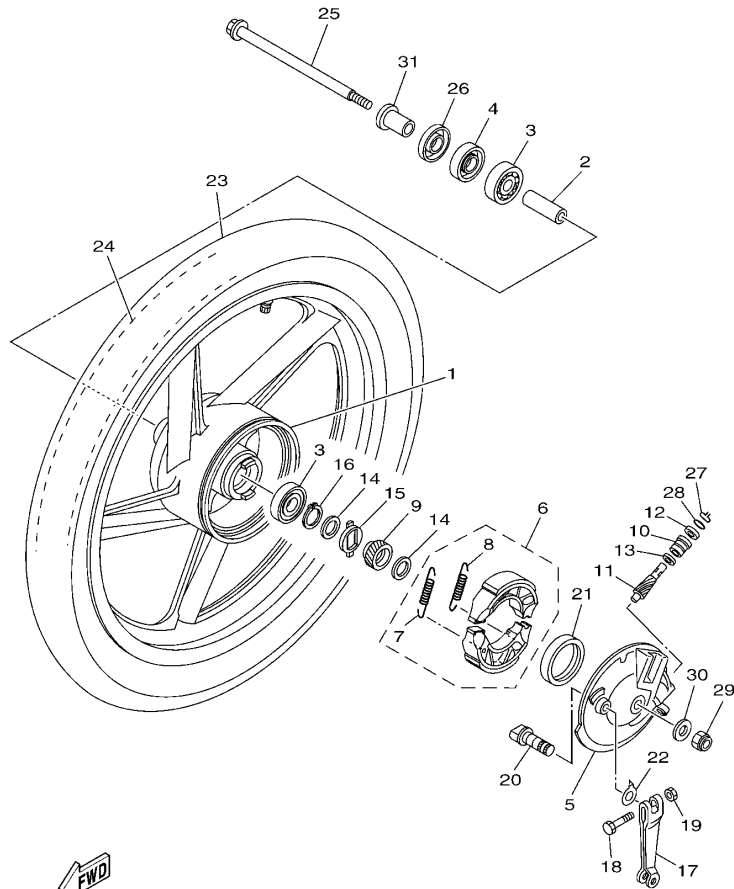



 1BK5415-M270

参照 号码	零件号码 PART NO.	零件名称 DESCRIPTION	1BK5	1BK6	1BK7	1BK8	备注 REMARKS
28	93210-14818	0 型环 O-RING			1		
29	90185-10807	自锁螺母 NUT, SELF-LOCKING			1		
30	90201-108C7	平垫圈 WASHER, PLATE			1		
31	90387-12840	轴套 COLLAR			1		

FIG. 28 前轮 3

FRONT WHEEL 3

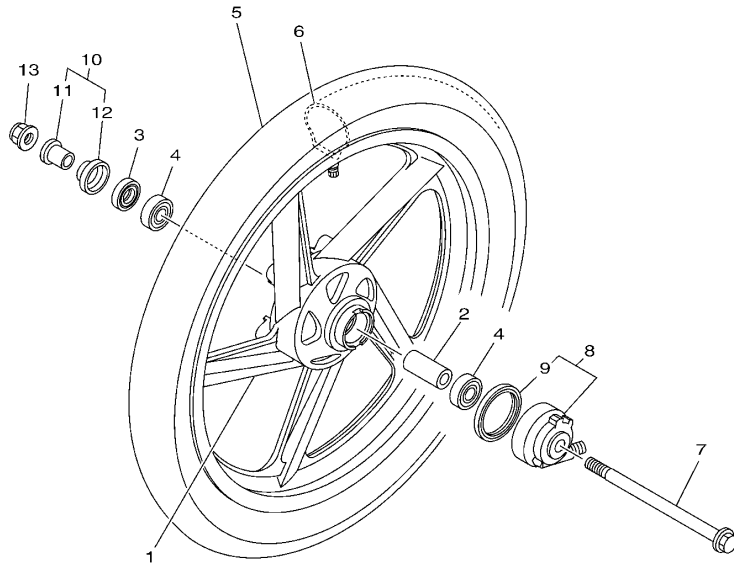
参照 号码	零件号码 PART NO.	零件名称 DESCRIPTION	1BK5	1BK6	1BK7	1BK8	备注 REMARKS
1	1BK-F5168-10-33	前压铸轮 CAST WHEEL, FRONT				1 1	雅马哈黑色 YB
2	90560-15293	衬套 SPACER				1 1	
3	93102-20857	油封 OIL SEAL				1 1	
4	93306-252YY	轴承 BEARING				2 2	
5	94127-18845	轮胎 (2.75-18) TIRE (2.75-18 329 6PR 48P TT)				1 1	WEIXING
6	94227-18818	内胎 (2.75-18) TUBE (2.75-18)				1 1	WEIXING
7	5VL-F5181-11	前轮轮轴 AXLE, WHEEL				1 1	
8	4GU-F5190-12	齿轮装置组合 GEAR UNIT ASSY				1 1	
9	93105-47808	油封 OIL SEAL				1 1	
10	4GU-F511X-01	轴套组 COLLAR				1 1	
11	90387-158K1	轴套 COLLAR				1 1	
12	4GU-F5118-00	轮毂防尘盖 COVER, HUB DUST				1 1	
13	95602-14200	自锁螺母 NUT, SELF-LOCKING				1 1	



1BK5415-M280

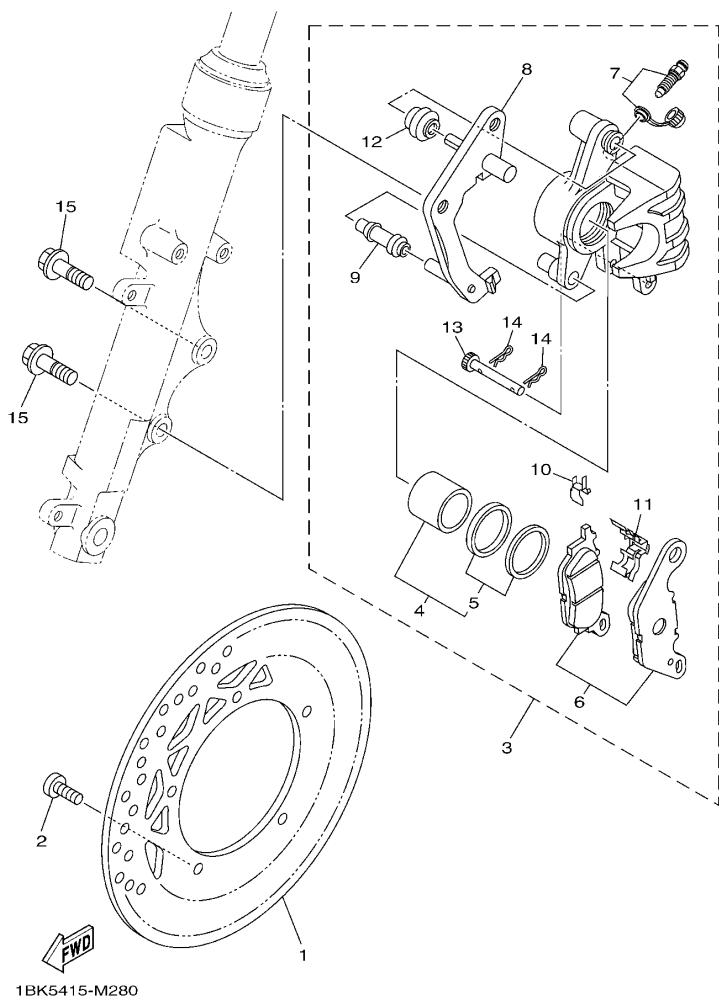
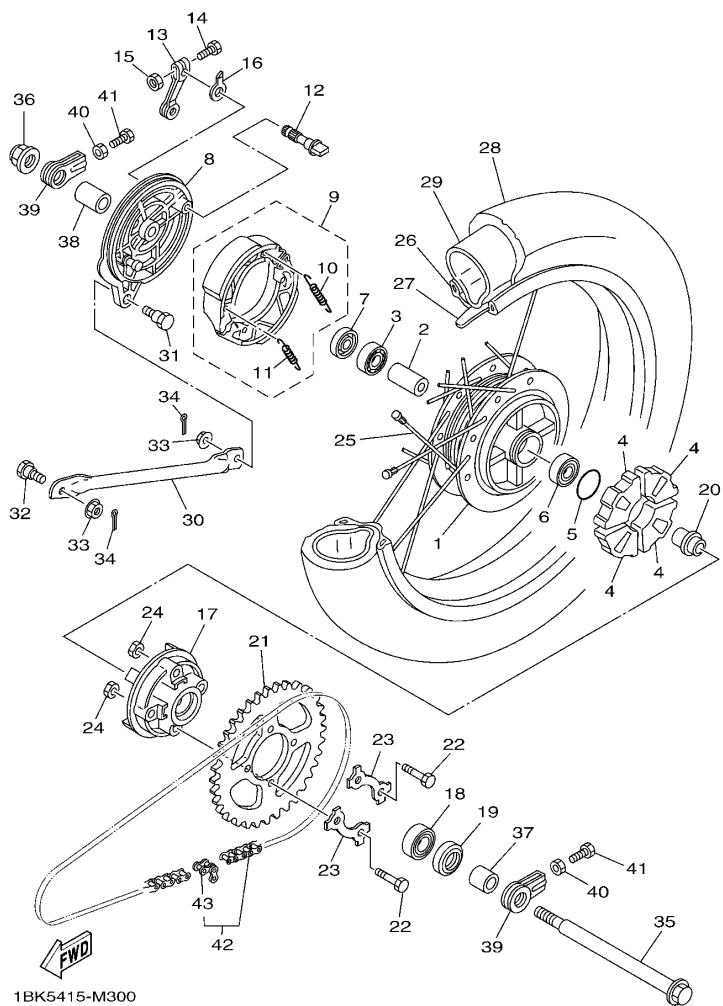

FIG. 29 前制动器卡钳

FRONT BRAKE CALIPER

参照 号码	零件号码 PART NO.	零件名称 DESCRIPTION	1BK5	1BK6	1BK7	1BK8	备注 REMARKS
1	1BK-F582U-00	制动盘 (右边) DISK, BRAKE (RIGHT)				1 1	
2	90111-08805	六角螺栓 BOLT, HEX. SOCKET BUTTON				5 5	
3	1SF-F580U-00	制动器卡钳组合 (右边) CALIPER ASSY (RIGHT)				1 1	
4	4S9-W0057-00	. 卡钳活塞组合 . PISTON ASSY, CALIPER				1 1	
5	4S9-W0047-00	. 卡钳密封套件 . CALIPER SEAL KIT				1 1	
6	4S9-W0045-00	. 刹车片组合 . BRAKE PAD KIT				1 1	
7	4S9-W0048-01	. 带孔螺钉套件 . BLEED SCREW KIT				1 1	
8	1SF-F5921-00	. 支承托架 . BRACKET, SUPPORT				1 1	
9	4S9-F5937-00	. 保护罩 2 . BOOT 2				1 1	
10	4S9-F5939-00	. 扣片 . CLIP, PAD				1 1	
11	4S9-F5919-00	. 衬垫支承 . SUPPORT, PAD				1 1	
12	4S9-F5917-00	. 卡钳套 . BOOT, CALIPER				1 1	
13	4S9-F5924-01	. 刹车片销 . PIN, PAD				1 1	
14	4S9-F5925-11	. 卡环 . CLIP				2 2	
15	90105-10831	凸缘螺栓 BOLT, FLANGE				2 2	



1BK5415-M300

FIG. 30 后轮

REAR WHEEL

参照 号码	零件号码 PART NO.	零件名称 DESCRIPTION	1BK5	1BK6	1BK7	1BK8	备注 REMARKS
1	5VL-F5311-00	后轮毂 HUB, REAR	1				
2	90387-15809	轴套 COLLAR	1				
3	93306-252YY	轴承 BEARING	1				
4	1KL-F5364-00	减震垫 DAMPER	4				
5	93210-42803	O型环 O-RING	1				
6	93306-252XA	轴承 BEARING	1				
7	93104-22802	油封 OIL SEAL	1				
8	1BK-F5321-00-35	后制动盖 PLATE, BRAKE SHOE	1				银色 SL
9	5VL-W2533-21	制动蹄块总成 BRAKE SHOE SET	1				
10	90506-12801	.拉簧 .SPRING, TENSION	1				
11	90506-15802	.拉簧 .SPRING, TENSION	1				
12	4GU-F5351-02	凸轮轴 CAMSHAFT	1				
13	5VL-F5355-01	制动臂 1 LEVER, CAMSHAFT	1				
14	90101-06848	螺栓 BOLT	1				
15	95302-06600	螺母 NUT	1				
16	4GU-F533A-01	指示片 PLATE, INDICATOR	1				
17	5VL-F5366-00	轮毂离合器 CLUTCH, HUB	1				
18	93306-054X3	轴承 BEARING	1				
19	93106-26812	油封 OIL SEAL	1				
20	5VL-F5387-01	链轮轴 AXLE, SPROCKET	1				
21	5VL-F5445-01	大链轮 SPROCKET, DRIVEN (45T)	1				
22	90109-08864	螺栓 BOLT	4				
23	5LK-F5412-01	垫片 WASHER	2				
24	90179-08639	螺母 NUT	4				
25	5VL-W5304-01	辐条套件 SPOKE SET, REAR	1				
26	94418-18802	轮辋 (1.85-18) RIM (1.85-18)	1				
27	94327-18800	轮辋箍带 (2.75-18) BAND, RIM (2.75-18)	1				CHENG SHIN

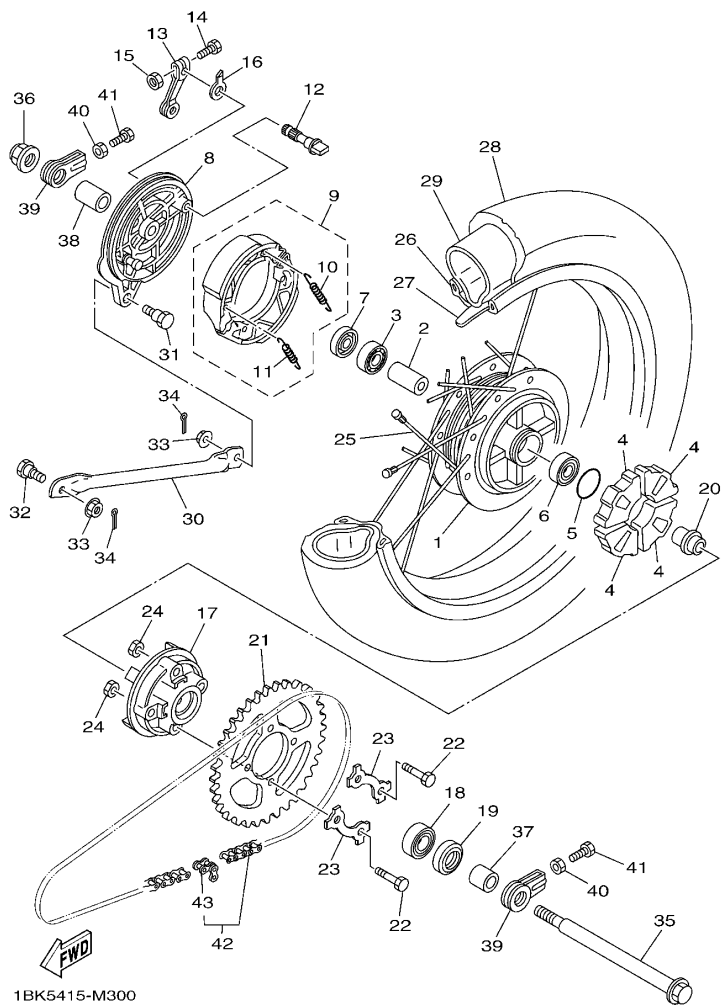

FIG. 30 后轮

REAR WHEEL

参照 号码	零件号码 PART NO.	零件名称 DESCRIPTION	1BK5	1BK6	1BK7	1BK8	备注 REMARKS
28	94109-18814	轮胎 (90/90-18 899A 6PR 57P TT) TIRE(90/90-18 899A 6PR 57P TT)	1				WEIXING
29	94209-18801	内胎 (90/90-18) TUBE (90/90-18)	1				WEIXING
30	5VL-F5371-00	拉杆 BAR, TENSION	1				
31	90109-08847	螺栓 BOLT	1				
32	90109-08848	螺栓 BOLT	1				
33	95702-08500	螺母 NUT, FLANGE	2				
34	91402-20012	开口销 PIN, COTTER	2				
35	5VL-F5381-01	后轮轮轴 AXLE, WHEEL	1				
36	95602-14200	自锁螺母 NUT, SELF-LOCKING	1				
37	5VL-F5386-01	链轮轴安装套 COLLAR, SPROCKET AXLE	1				
38	5VL-F5377-01	轴套 COLLAR, WHEEL	1				
39	5VL-F5388-01	链条张紧板 1 PULLER, CHAIN 1	2				
40	95312-08600	螺母 NUT	2				
41	90153-08804	六角头螺钉 SCREW, HEXAGON	2				
42	5VL-F53C0-10	链条总成 CHAIN (DID428H 118L)	1				
43	94668-E2001	链条接头 .JOINT, CHAIN (DID 428H)	1				

FIG. 31 后轮 2

REAR WHEEL 2

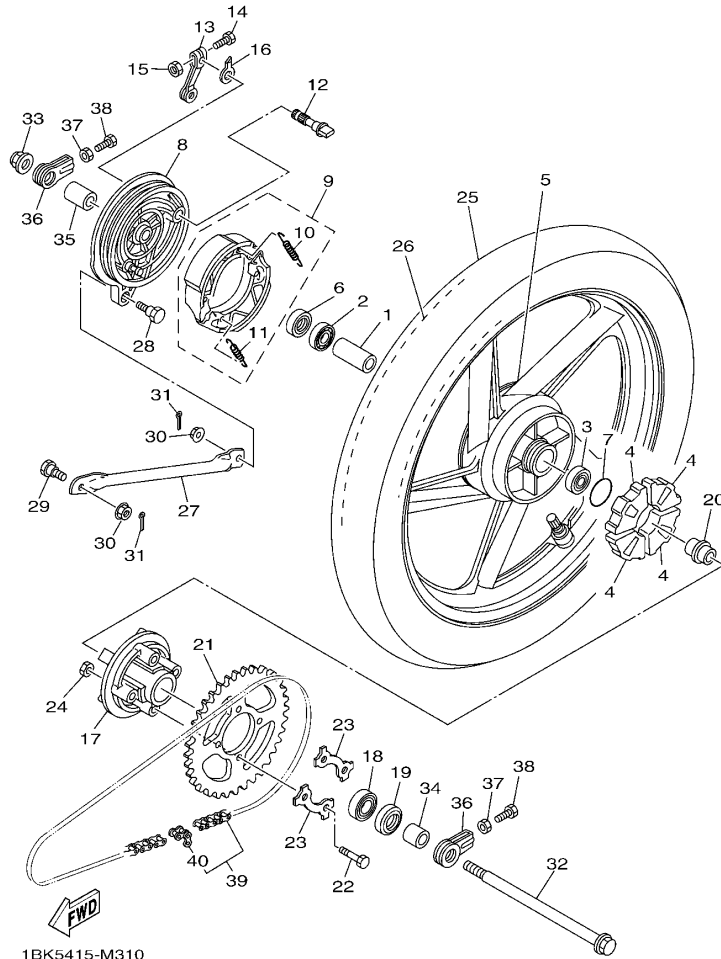

1BK5415-M310

参照 号码	零件号码 PART NO.	零件名称 DESCRIPTION	1BK5	1BK6	1BK7	1BK8	备注 REMARKS
1	90387-15809	轴套 COLLAR		1	1	1	
2	93306-252YY	轴承 BEARING		1	1	1	
3	93306-252XA	轴承 BEARING		1	1	1	
4	1KL-F5364-00	减震垫 DAMPER		4	4	4	
5	1BK-F5338-00-33	后压铸轮 CAST WHEEL, REAR		1	1	1	雅马哈黑色 YB
6	93104-22802	油封 OIL SEAL		1	1	1	
7	93210-42807	O型环 O-RING		1	1	1	
8	1BK-F5321-00-33	后制动盖 PLATE, BRAKE SHOE		1	1	1	雅马哈黑色 YB
9	5VL-W2533-21	制动蹄块总成 BRAKE SHOE SET		1	1	1	
10	90506-12801	拉簧 .SPRING, TENSION		1	1	1	
11	90506-15802	拉簧 .SPRING, TENSION		1	1	1	
12	4GU-F5351-02	凸轮轴 CAMSHAFT		1	1	1	
13	5VL-F5355-01	制动臂 1 LEVER, CAMSHAFT		1	1	1	
14	90101-06848	螺栓 BOLT		1	1	1	
15	95302-06600	螺母 NUT		1	1	1	
16	4GU-F533A-01	指示片 PLATE, INDICATOR		1	1	1	
17	5VL-F5366-00	轮毂离合器 CLUTCH, HUB		1	1	1	
18	93306-054X3	轴承 BEARING		1	1	1	
19	93106-26812	油封 OIL SEAL		1	1	1	
20	5VL-F5387-01	链轮轴 AXLE, SPROCKET		1	1	1	
21	5VL-F5445-01	大链轮 SPROCKET, DRIVEN (45T)		1	1	1	
22	90109-08864	螺栓 BOLT		4	4	4	
23	5LK-F5412-01	垫片 WASHER		2	2	2	
24	90179-08639	螺母 NUT		4	4	4	
25	94109-18814	轮胎 (90/90-18 899A 6PR 57P TT) TIRE (90/90-18 899A 6PR 57P TT)		1	1	1	WEIXING
26	94209-18801	内胎 (90/90-18) TUBE (90/90-18)		1	1	1	WEIXING
27	5VL-F5371-00	拉杆 BAR, TENSION		1	1	1	

FIG. 31 后轮 2

REAR WHEEL 2

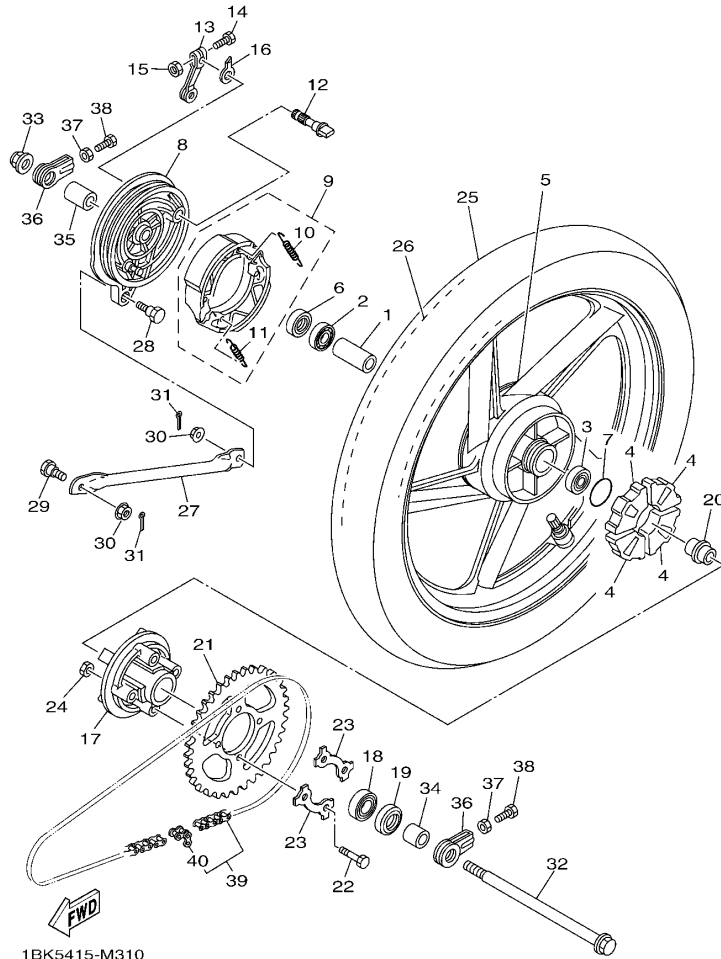

1BK5415-M310

参照 号码	零件号码 PART NO.	零件名称 DESCRIPTION	1BK5	1BK6	1BK7	1BK8	备注 REMARKS
28	90109-08847	螺栓 BOLT		1	1	1	
29	90109-08848	螺栓 BOLT		1	1	1	
30	95702-08500	螺母 NUT, FLANGE		2	2	2	
31	91402-20012	开口销 PIN, COTTER		2	2	2	
32	5VL-F5381-01	后轮轴 AXLE, WHEEL		1	1	1	
33	95602-14200	自锁螺母 NUT, SELF-LOCKING		1	1	1	
34	5VL-F5386-01	链轮轴安装套 COLLAR, SPROCKET AXLE		1	1	1	
35	5VL-F5377-01	轴套 COLLAR, WHEEL		1	1	1	
36	5VL-F5388-01	链条张紧板 1 PULLER, CHAIN 1		2	2	2	
37	95312-08600	螺母 NUT		2	2	2	
38	90153-08804	六角头螺钉 SCREW, HEXAGON		2	2	2	
39	5VL-F53C0-10	链条总成 CHAIN (DID428H 118L)		1	1	1	
40	94668-E2001	链条接头 .JOINT, CHAIN (DID 428H)		1	1	1	

FIG. 32 操纵手柄 钢索(鼓刹)

STEERING CABLE FOR DRUM BRAKE

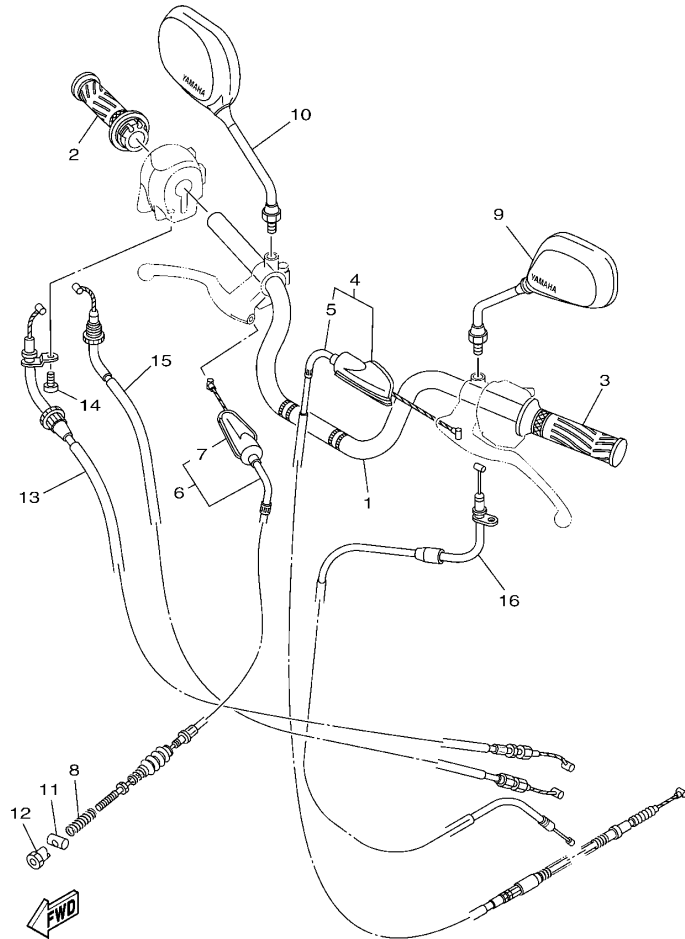

1BK5415-M320

参照 号码	零件号码 PART NO.	零件名称 DESCRIPTION	1BK5	1BK6	1BK7	1BK8	备注 REMARKS
1	13R-F6111-00	手把 HANDLEBAR	1	1			
2	1SF-F6240-00	握把(右边) GRIP ASSY	1	1			
3	5VL-F6241-00	握把(左边) GRIP	1	1			
4	5VL-F6335-11	离合器拉索 CABLE, CLUTCH	1	1			
5	5VL-F6372-01	.手柄套 1 .COVER, HANDLE LEVER 1	1	1			
6	5VL-F6341-11	制动拉索 1 WIRE, BRAKE 1	1	1			
7	5VL-F6372-01	.手柄套 1 .COVER, HANDLE LEVER 1	1	1			
8	90501-08803	压簧 SPRING, COMPRESSION	1	1			
9	13R-F6280-00	后视镜组合(左边) REAR VIEW MIRROR ASSY (LEFT)	1	1			
10	13R-F6290-00	后视镜组合(右边) REAR VIEW MIRROR ASSY (RIGHT)	1	1			
11	90249-12808	销 PIN	1	1			
12	90179-06826	螺母 NUT	1	1			
13	2D0-F6311-01	节气门拉索 1 CABLE, THROTTLE 1	1	1			
14	98502-05010	十字螺钉 SCREW, PAN HEAD	1	1			
15	2D0-F6312-01	节气门拉索 2 CABLE, THROTTLE 2	1	1			
16	1SF-F6331-00	起动机钢索 CABLE, STARTER 1	1	1			

FIG. 33 操纵手柄 钢索(碟刹)

STEERING CABLE FOR DISK BRAKE

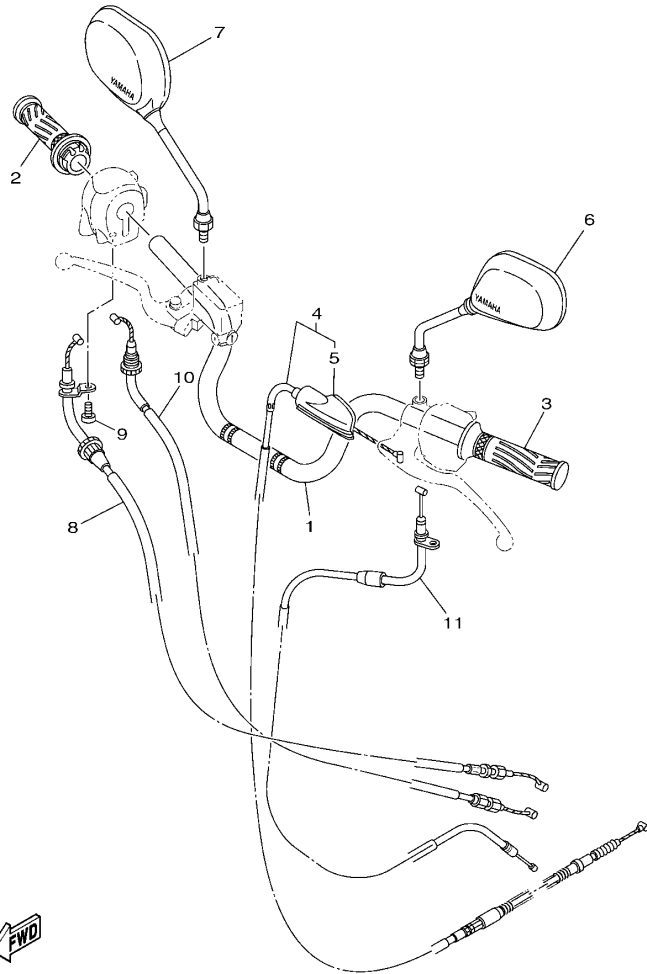

参照 号码	零件号码 PART NO.	零件名称 DESCRIPTION	1BK5	1BK6	1BK7	1BK8	备注 REMARKS
1	13R-F6111-00	手把 HANDLEBAR			1	1	
2	1SF-F6240-00	握把(右边) GRIP ASSY			1	1	
3	5VL-F6241-00	握把(左边) GRIP			1	1	
4	5VL-F6335-11	离合器拉索 CABLE, CLUTCH			1	1	
5	5VL-F6372-01	手柄套 1 .COVER, HANDLE LEVER 1			1	1	
6	13R-F6280-00	后视镜组合(左边) REAR VIEW MIRROR ASSY (LEFT)			1	1	
7	13R-F6290-00	后视镜组合(右边) REAR VIEW MIRROR ASSY (RIGHT)			1	1	
8	2D0-F6311-01	节气门拉索 1 CABLE, THROTTLE 1			1	1	
9	98502-05010	十字螺钉 SCREW, PAN HEAD			1	1	
10	2D0-F6312-01	节气门拉索 2 CABLE, THROTTLE 2			1	1	
11	1SF-F6331-00	起动机钢索 CABLE, STARTER 1			1	1	

1BK5415-M330

FIG. 34 前主缸

FRONT MASTER CYLINDER

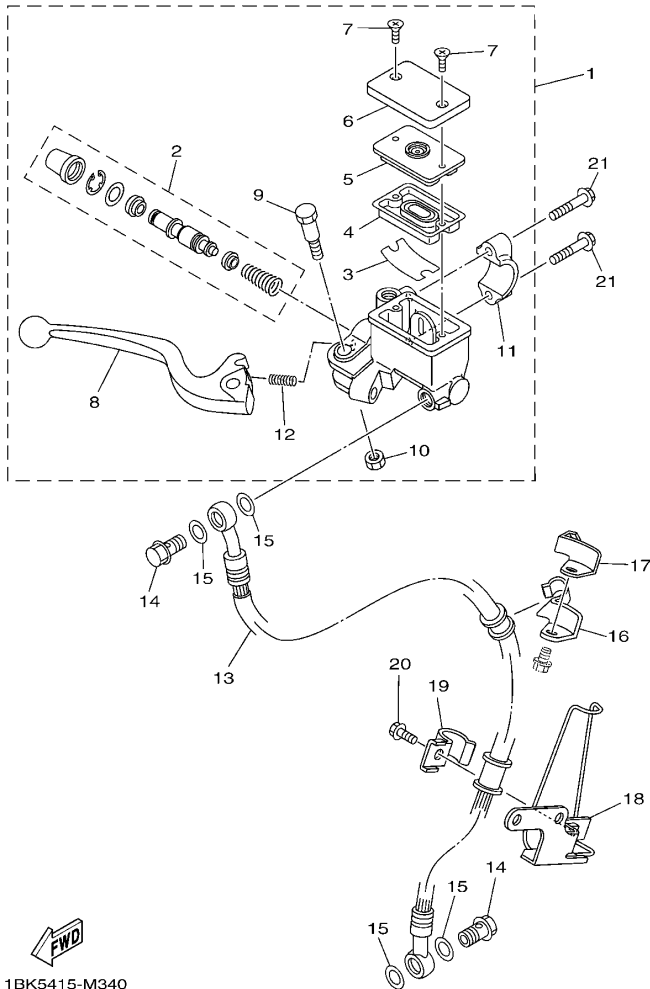

1BK5415-M340

参照 号码	零件号码 PART NO.	零件名称 DESCRIPTION	1BK5	1BK6	1BK7	1BK8	备注 REMARKS
1	1SF-F583T-00	前主缸组合 MASTER CYLINDER ASSY			1	1	
2	1SF-W0041-00	前主缸套件 CYLINDER KIT, MASTER			1	1	
3	1SF-F5896-00	储油箱面板 PLATE, RESERVOIR			1	1	
4	1SF-F5854-00	油箱隔膜 DIAPHRAGM, RESERVOIR			1	1	
5	1SF-F585B-00	隔板 PLATE, DIAPHRAGM			1	1	
6	1SF-F5852-00	储油箱盖 CAP, RESERVOIR			1	1	
7	1SF-F589H-00	螺钉 SCREW			2	2	
8	1SF-H3922-00	手柄 2 LEVER 2			1	1	
9	4S9-F589F-00	手柄螺栓 BOLT, LEVER			1	1	
10	4S9-F586F-00	自锁螺母 NUT, U			1	1	
11	1SF-F5867-00	主缸托架 BRACKET, MASTER CYLINDER			1	1	
12	1SF-F5865-00	弹簧座 SPRING, SEAT			1	1	
13	5VL-F5872-11	制动软管 1 HOSE, BRAKE 1			1	1	
14	90401-10811	螺栓 BOLT, UNION			2	2	
15	90201-108J9	平垫圈 WASHER, PLATE			4	4	
16	5VL-F5887-00	制动软管支架 HOLDER, BRAKE HOSE			1	1	
17	5VL-F5886-00	制动软管支架 HOLDER, BRAKE HOSE			1	1	
18	5VL-F5875-01	制动软管支架 1 HOLDER, BRAKE HOSE 1			1	1	
19	5VL-F5876-00	制动软管支架 2 HOLDER, BRAKE HOSE 2			1	1	
20	95022-06016	凸缘螺栓 BOLT, FLANGE			1	1	
21	95022-06025	凸缘螺栓 BOLT, FLANGE			2	2	

FIG. 35 搁脚·支架

STAND & FOOTREST

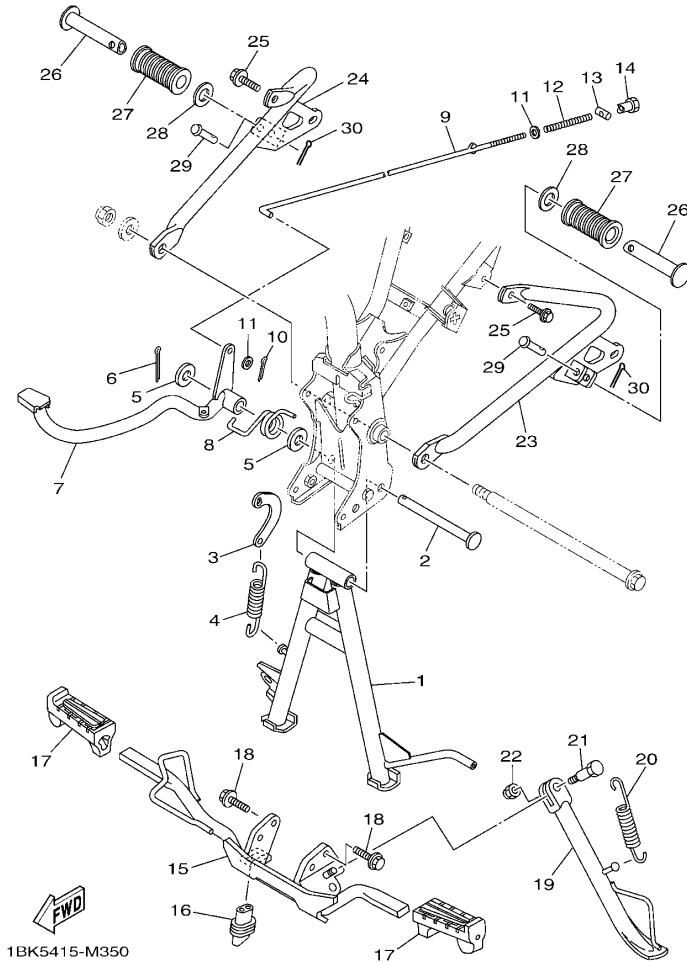

参照 号码	零件号码 PART NO.	零件名称 DESCRIPTION	1BK5	1BK6	1BK7	1BK8	备注 REMARKS
1	1BK-F7111-00	主支承 STAND, MAIN	1	1	1	1	
2	2D0-F7112-02	主支承轴 SHAFT, MAIN STAND	1	1	1	1	
3	5VL-F7115-01	连接板 LINK, MAIN STAND	1	1	1	1	
4	90506-32800	拉簧 SPRING, TENSION	1	1	1	1	
5	90201-15815	平垫圈 WASHER, PLATE	2	2	2	2	
6	91402-30025	开口销 PIN, COTTER	1	1	1	1	
7	1SF-F7211-00	制动踏板 PEDAL, BRAKE	1	1	1	1	
8	90508-40801	扭簧 SPRING, TORSION	1	1	1	1	
9	5VL-F7231-01	制动拉杆 ROD, BRAKE	1	1	1	1	
10	91402-20012	开口销 PIN, COTTER	1	1	1	1	
11	92902-06200	垫圈 WASHER	2	2	2	2	
12	90501-10806	压簧 SPRING, COMPRESSION	1	1	1	1	
13	90249-12808	销 PIN	1	1	1	1	
14	90179-06826	螺母 NUT	1	1	1	1	
15	1SF-F7411-00	搁脚板 1 FOOTREST 1	1	1	1	1	
16	5VL-H2109-00	软管接头 JOINT, HOSE	1	1	1	1	
17	5VL-F7413-00	搁脚套 COVER, FOOTREST	2	2	2	2	
18	95812-08020	凸缘螺栓 BOLT, FLANGE	2	2	2	2	
19	5VL-F7311-00	侧支承 STAND, SIDE	1	1	1	1	
20	90506-29800	拉簧 SPRING, TENSION	1	1	1	1	
21	90109-10849	螺栓 BOLT	1	1	1	1	
22	90185-10807	自锁螺母 NUT, SELF-LOCKING	1	1	1	1	
23	1BK-F7452-00	搁脚板托架 1 BRACKET, FOOTREST 1	1	1	1	1	
24	2D0-F7462-20	搁脚板托架 2 BRACKET, FOOTREST 2	1	1	1	1	
25	95812-08020	凸缘螺栓 BOLT, FLANGE	2	2	2	2	
26	47V-F7431-01	后搁脚板 1 FOOTREST, REAR 1	2	2	2	2	
27	4FP-F7433-00	后搁脚板套 COVER, REAR FOOTREST	2	2	2	2	

FIG. 35 搁脚·支架

STAND & FOOTREST

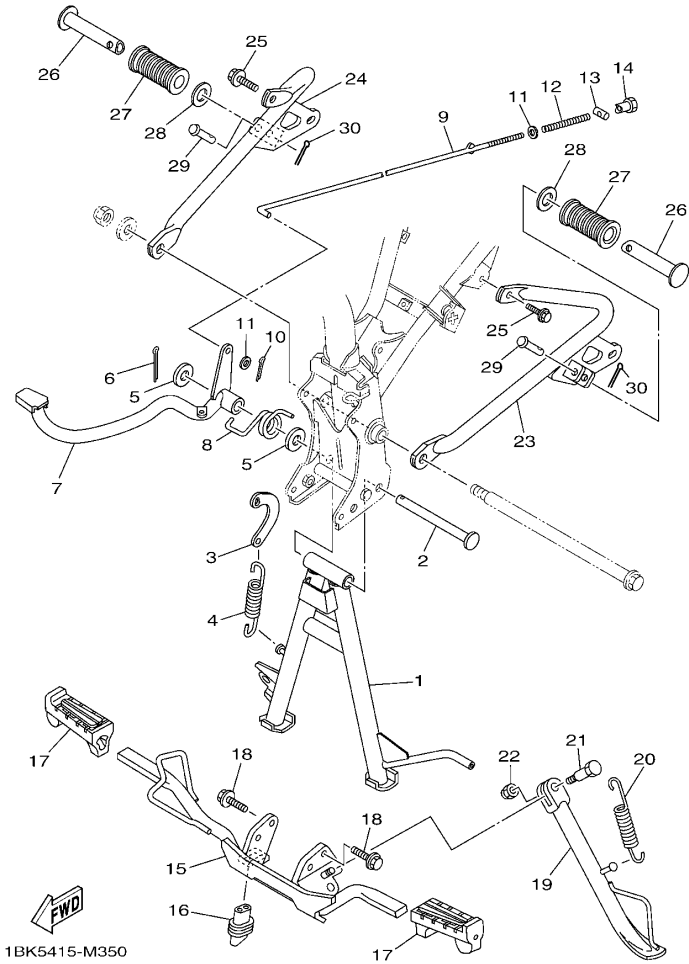

参照 号码	零件号码 PART NO.	零件名称 DESCRIPTION	1BK5	1BK6	1BK7	1BK8	备注 REMARKS
28	90201-208D4	平垫圈 WASHER, PLATE	2	2	2	2	
29	90240-06806	销 PIN, CLEVIS	2	2	2	2	
30	91402-16012	开口销 PIN, COTTER	2	2	2	2	

FIG. 36 导流罩 1

COWLING 1

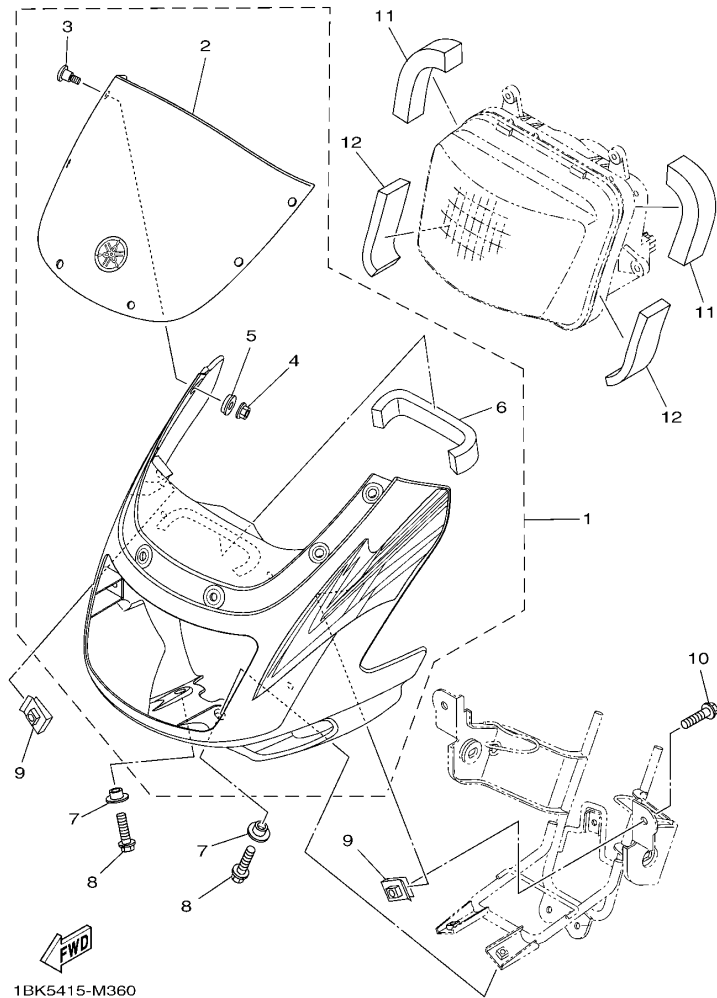

参照 号码	零件号码 PART NO.	零件名称 DESCRIPTION	1BK5	1BK6	1BK7	1BK8	备注 REMARKS
1	1BK-W2835-01-P0	整流罩总成 COWLING ASSY				1	UR 鸡尾酒鲜红色 7 车用 UR FOR VRC7
	1BK-W2835-01-P1	整流罩总成 COWLING ASSY				1	UR 金属黑色 车用 UR FOR SMX
	1BK-W2835-01-P2	整流罩总成 COWLING ASSY				1	UR 浅紫深蓝色 车用 UR FOR DPBMC
2	1BK-W8381-00	.挡风玻璃总成 .WINDSHIELD ASSY				1	
3	90149-05800	.螺钉 .SCREW				6	
4	95702-05500	.螺母 .NUT, FLANGE				6	
5	5VL-F8215-01	.专用垫圈 .WASHER, SPECIAL				6	
6	90520-20808	.面板减震器 .DAMPER, PLATE				1	
7	90387-07818	轴套 COLLAR				2	
8	95802-06016	凸缘螺栓 BOLT, FLANGE				2	
9	5VL-F1535-01	螺母 1 NUT 1				2	
10	95802-06016	凸缘螺栓 BOLT, FLANGE				2	
11	90520-20809	面板减震器 DAMPER, PLATE				2	
12	90520-10812	面板减震器 DAMPER, PLATE				2	

FIG. 37 发电机

GENERATOR

参照 号码	零件号码 PART NO.	零件名称 DESCRIPTION	1BK5	1BK6	1BK7	1BK8	备注 REMARKS
1	1BK-H1450-00	转子组合 ROTOR ASSY	1	1			
	1SF-H1450-20	转子组合 ROTOR ASSY			1	1	
2	13R-H1410-00	定子组合 STATOR ASSY	1	1			
	1SF-H1410-20	定子组合 STATOR ASSY			1	1	
3	91312-06025	螺栓 BOLT	3	3	3	3	
4	91312-06014	螺栓 BOLT	2	2	2	2	

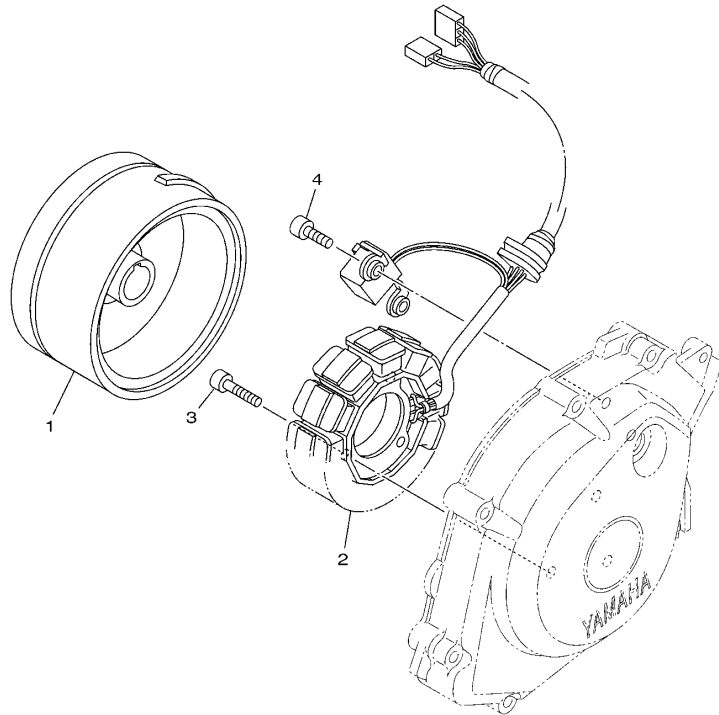

1SF1415-L350

FIG. 38 起动机

STARTING MOTOR

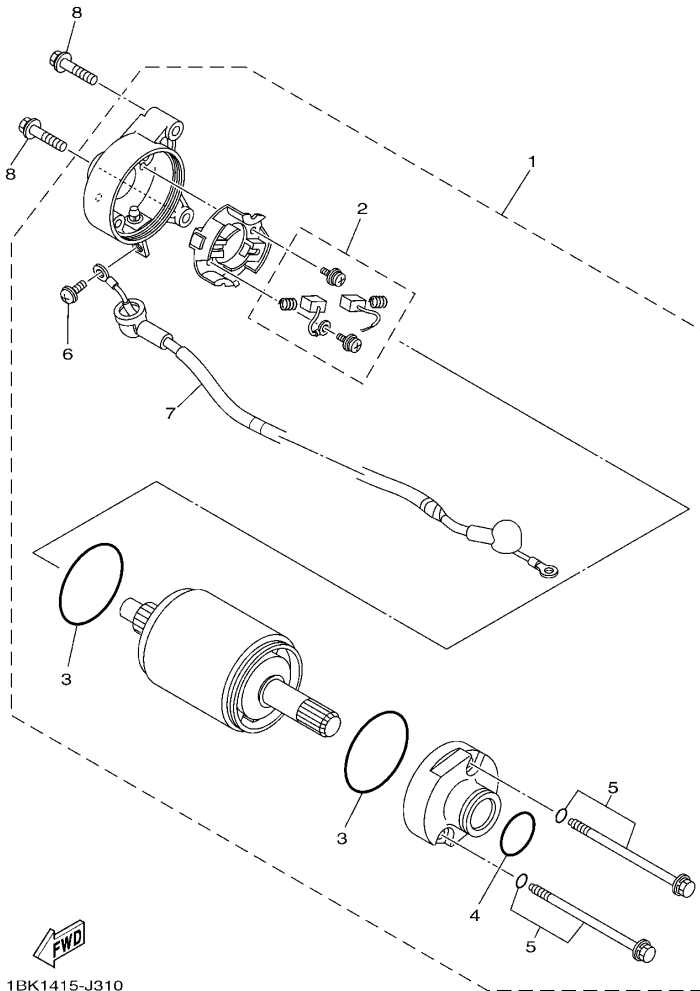

1BK1415-J310

参照 号码	零件号 PART NO.	零件名称 DESCRIPTION	1BK5	1BK6	1BK7	1BK8	备注 REMARKS
1	1BK-H1800-10	起动机组合 STARTING MOTOR ASSY	1	1	1	1	
2	2D0-H1801-00	.碳刷组件 .BRUSH SET	1	1	1	1	
3	93210-54807	.O型环 .O-RING	2	2	2	2	
4	1BK-H1168-00	.O型 .O-RING	1	1	1	1	
5	2D0-H1828-00	.组合螺钉 .SCREW 2	2	2	2	2	
6	98902-05008	.十字槽盘头螺钉 .SCREW, BIND	1	1	1	1	
7	1BK-H183G-00	.导线组件 .CORD COMP.	1	1	1	1	
8	95022-06025	.凸缘螺栓 BOLT, FLANGE	2	2	2	2	

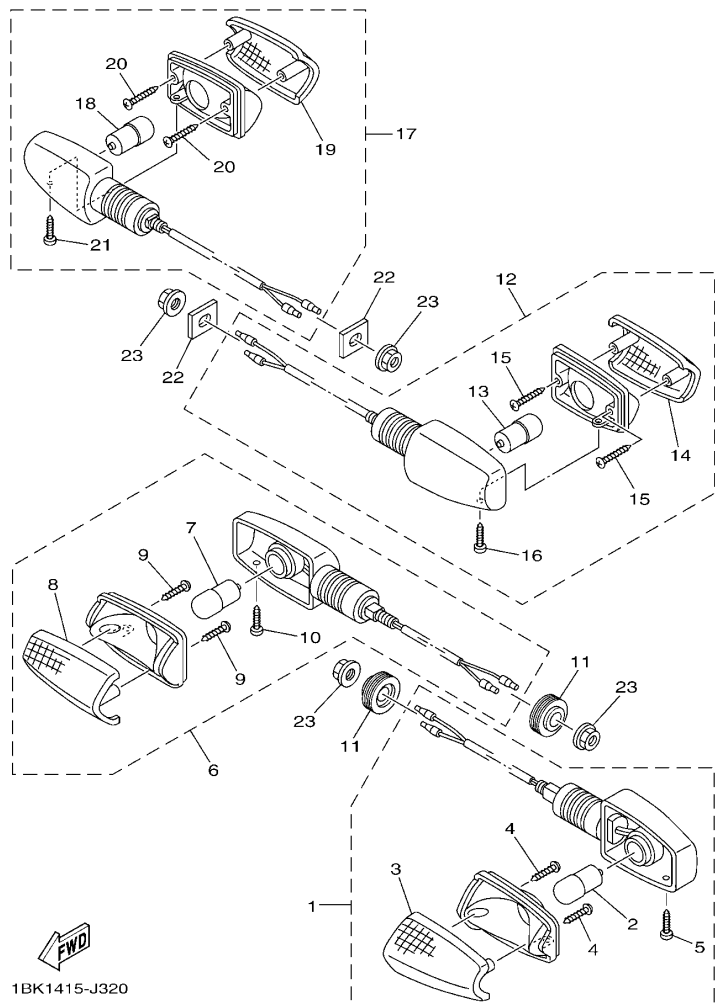

FIG. 39 转向灯

FLASHER LIGHT

参照 号码	零件号码 PART NO.	零件名称 DESCRIPTION	1BK5	1BK6	1BK7	1BK8	备注 REMARKS
1	1BK-H3310-00	前转向灯组合 1 FRONT FLASHER LIGHT ASSY 1	1	1			
2	4FP-H3311-00	.转向灯灯泡 .BULB, FLASHER (12V-10W)	1	1			
3	1BK-H3312-00	.闪烁器镜面 .LENS, FLASHER	1	1			
4	1BK-H3333-00	.镜面安装螺钉 .SCREW, LENS FITTING	2	2			
5	1BK-H338B-00	.特制螺钉 .SCREW, SPECIAL	1	1			
6	1BK-H3320-00	前转向灯组合 2 FRONT FLASHER LIGHT ASSY 2	1	1			
7	4FP-H3311-00	.转向灯灯泡 .BULB, FLASHER (12V-10W)	1	1			
8	1BK-H3312-00	.闪烁器镜面 .LENS, FLASHER	1	1			
9	1BK-H3333-00	.镜面安装螺钉 .SCREW, LENS FITTING	2	2			
10	1BK-H338B-00	.特制螺钉 .SCREW, SPECIAL	1	1			
11	5VL-H3321-00	闪烁灯减震块 1 DAMPER, FLASHER 1	2	2			
12	1BK-H3330-00	后转向灯组合 1 REAR FLASHER LIGHT ASSY 1	1	1			
13	4FP-H3311-00	.转向灯灯泡 .BULB, FLASHER (12V-10W)	1	1			
14	1BK-H3312-00	.闪烁器镜面 .LENS, FLASHER	1	1			
15	1BK-H3333-00	.镜面安装螺钉 .SCREW, LENS FITTING	2	2			
16	1BK-H338B-00	.特制螺钉 .SCREW, SPECIAL	1	1			
17	1BK-H3340-00	后转向灯组合 2 REAR FLASHER LIGHT ASSY 2	1	1			
18	4FP-H3311-00	.转向灯灯泡 .BULB, FLASHER (12V-10W)	1	1			
19	1BK-H3312-00	.闪烁器镜面 .LENS, FLASHER	1	1			
20	1BK-H3333-00	.镜面安装螺钉 .SCREW, LENS FITTING	2	2			
21	1BK-H338B-00	.特制螺钉 .SCREW, SPECIAL	1	1			
22	5VL-H3359-01	特制垫圈 WASHER, SPECIAL	2	2			
23	95702-10500	螺母 NUT, FLANGE	4	4			

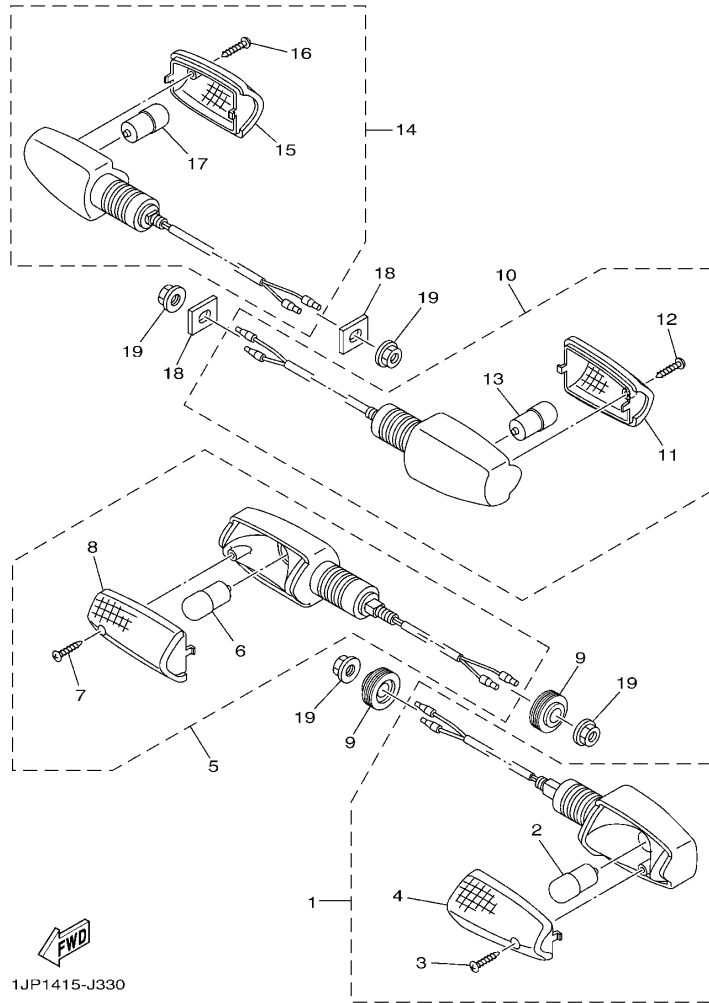
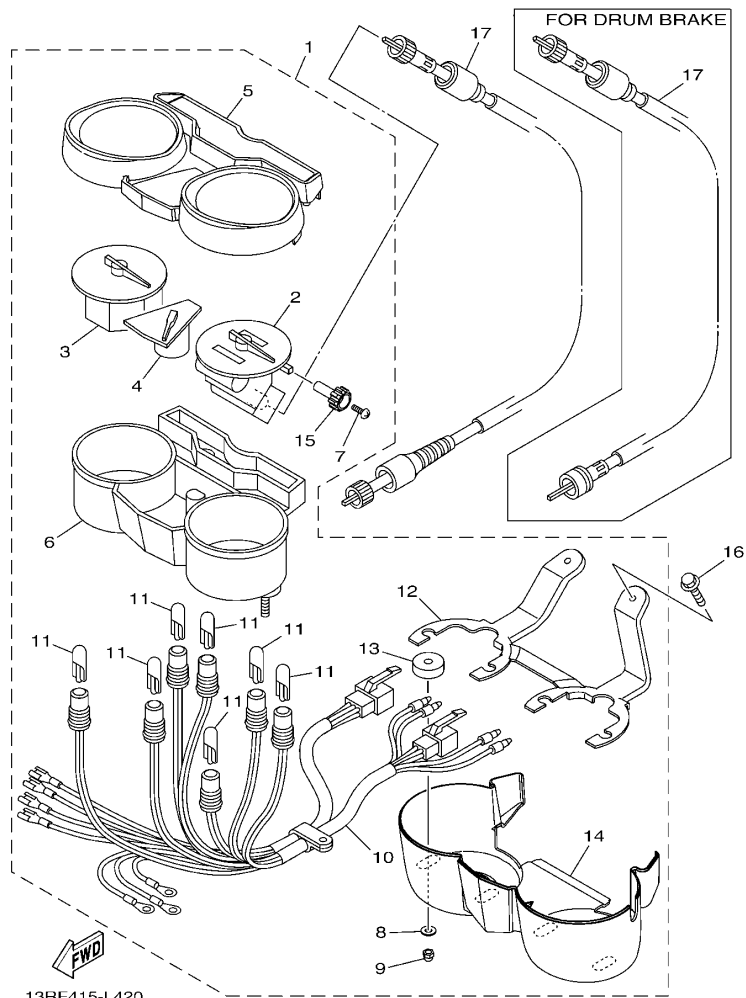

FIG. 40 转向灯 2

FLASHER LIGHT 2

参照 号码	零件号码 PART NO.	零件名称 DESCRIPTION	1BK5	1BK6	1BK7	1BK8	备注 REMARKS
1	1BK-H3310-10	前转向灯组合 1 FRONT FLASHER LIGHT ASSY 1				1 1	
2	4GU-H3311-10	.转向灯灯泡 .BULB, FLASHER (10W)				1 1	
3	1BK-H338B-10	.特制螺钉 .SCREW, SPECIAL				1 1	
4	1BK-H333A-10	.透镜组件 1 .LENS COMP 1				1 1	
5	1BK-H3320-10	前转向灯组合 2 FRONT FLASHER LIGHT ASSY 2				1 1	
6	4GU-H3311-10	.转向灯灯泡 .BULB, FLASHER (10W)				1 1	
7	1BK-H338B-10	.特制螺钉 .SCREW, SPECIAL				1 1	
8	1BK-H334A-10	.透镜组件 2 .LENS COMP 2				1 1	
9	5VL-H3321-00	闪烁灯减震块 1 DAMPER, FLASHER 1				2 2	
10	1BK-H3330-10	后转向灯组合 1 REAR FLASHER LIGHT ASSY 1				1 1	
11	1BK-H334A-10	.透镜组件 2 .LENS COMP 2				1 1	
12	1BK-H338B-10	.特制螺钉 .SCREW, SPECIAL				1 1	
13	4GU-H3311-10	.转向灯灯泡 .BULB, FLASHER (10W)				1 1	
14	1BK-H3340-10	后转向灯组合 2 REAR FLASHER LIGHT ASSY 2				1 1	
15	1BK-H333A-10	.透镜组件 1 .LENS COMP 1				1 1	
16	1BK-H338B-10	.特制螺钉 .SCREW, SPECIAL				1 1	
17	4GU-H3311-10	.转向灯灯泡 .BULB, FLASHER (10W)				1 1	
18	5VL-H3359-01	特制垫圈 WASHER, SPECIAL				2 2	
19	95702-10500	螺母 NUT, FLANGE				4 4	



13RF415-L420

FIG. 41 仪表

METER

参照 号码	零件号码 PART NO.	零件名称 DESCRIPTION	1BK5	1BK6	1BK7	1BK8	备注 REMARKS
1	1BK-H3500-40	仪表组合 METER ASSY	1	1	1	1	
2	1BK-HA251-40	.驱动装置 1 .DRIVE UNIT 1	1	1	1	1	
3	1BK-HA252-40	.驱动装置 2 .DRIVE UNIT 2	1	1	1	1	
4	13R-HA253-00	.驱动装置 3 .DRIVE	1	1	1	1	
5	13R-H353G-00	.上侧箱 .CASE, UPPER	1	1	1	1	
6	13R-H358L-00	.箱组 .CASE UNIT	1	1	1	1	
7	5VL-H353S-00	.旋钮安装螺钉 .SCREW, KNOB FITTING	1	1	1	1	
8	13R-H3524-00	.专用垫圈 .WASHER, SPECIAL	4	4	4	4	
9	1BK-H354P-00	.螺母 .NUT	4	4	4	4	
10	13R-H3509-00	.导线组合 .SOCKET CORD ASSY	1	1	1	1	
11	4FP-H3517-10	.灯泡 .BULB (12V-1.7W)	7	7	7	7	
12	5VL-H350E-00	.支架 .BRACKET	1	1	1	1	
13	5VL-H3543-00	.减震器托架 .DAMPER, BRACKET	4	4	4	4	
14	18C-H353H-00	.下仪表盖 .CASE, UNDER	1	1	1	1	
15	5VL-H357H-00	.回零旋钮 .KNOB	1	1	1	1	
16	95022-06016	凸缘螺栓 BOLT, FLANGE	2	2	2	2	
	5VL-H3550-23	速度计软轴组合 SPEEDOMETER CABLE ASSY	1	1			
	5VL-H3550-12	速度计软轴组合 SPEEDOMETER CABLE ASSY			1	1	

FIG. 42 前大灯

HEADLIGHT

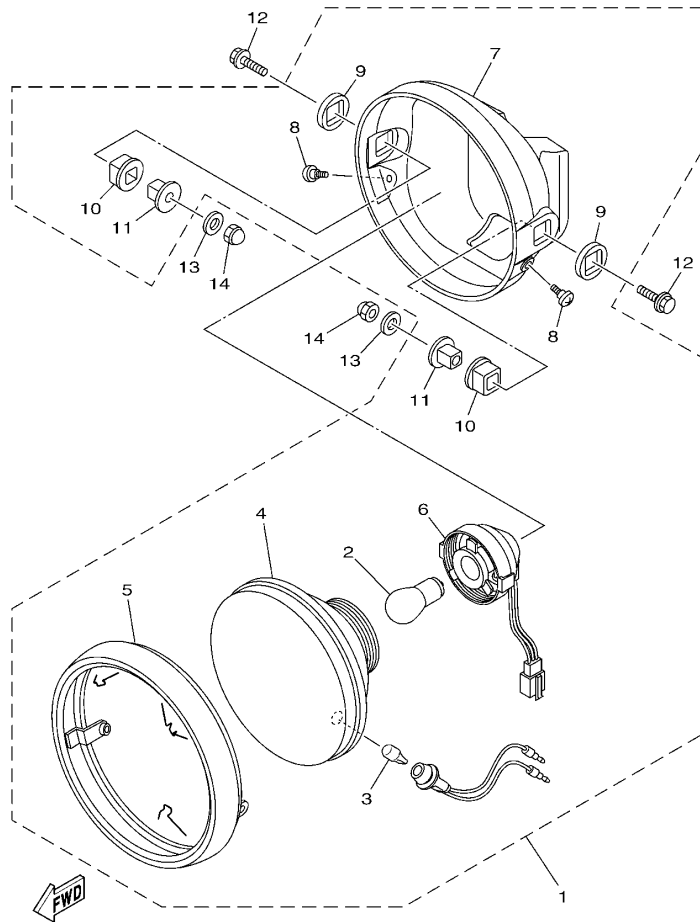

1BK5415-M420

参照 号码	零件号码 PART NO.	零件名称 DESCRIPTION	1BK5	1BK6	1BK7	1BK8	备注 REMARKS
1	5VL-H4300-51	前照灯组合 HEADLIGHT ASSY	1	1	1		
2	13R-H4314-00	.前照灯灯泡 .BULB, HEADLIGHT (12V-35/35W)	1	1	1		
3	4GU-H4347-10	.灯泡 .BULB (12V-5W)	1	1	1		
4	5VL-H4321-50	.镜面 .LENS ASSY	1	1	1		
5	5VL-H4310-50	.前灯灯框 .RIM, HEADLIGHT	1	1	1		
6	5VL-H4375-40	.灯座 .FITTING PLATE, BULB	1	1	1		
7	5VL-H4311-51	.前照灯本 .BODY, HEADLIGHT	1	1	1		
8	1BK-H4526-00	.螺钉 .SCREW	2	2	2		
9	5VL-H4164-40	.衬套 .DAMPER	2	2	2		
10	5VL-H4163-40	.衬套 .DAMPER	2	2	2		
11	5VL-H4145-40	.套管 .COLLAR, BODY FITTING	2	2	2		
12	95023-08030	螺栓 BOLT	2	2	2		
13	90201-08830	平垫圈 WASHER, PLATE	2	2	2		
14	95302-08800	盖形螺母 NUT, CROWN	2	2	2		

FIG. 43 前大灯 2

HEADLIGHT 2

参照 号码	零件号码 PART NO.	零件名称 DESCRIPTION	1BK5	1BK6	1BK7	1BK8	备注 REMARKS
1	5VL-H4310-31	大灯组件 HEADLIGHT UNIT ASSY				1	
2	5VL-H4314-10	.前照灯灯泡 .BULB, HEADLIGHT (12V-35/35W)				1	
3	5VL-H4330-31	.灯体组合 .BODY ASSY				1	
4	4GU-H4347-10	.灯泡 .BULB (12V-5W)				1	
5	5VL-H4359-30	.大灯导线 .CORD, HEADLIGHT				1	
6	5VL-H4378-30	.盖 .CAP				1	
7	95802-06020	凸缘螺栓 BOLT, FLANGE				2	
8	5VL-F1535-01	螺母 1 NUT 1				2	
9	97702-50020	自攻螺钉 SCREW, TAPPING				2	

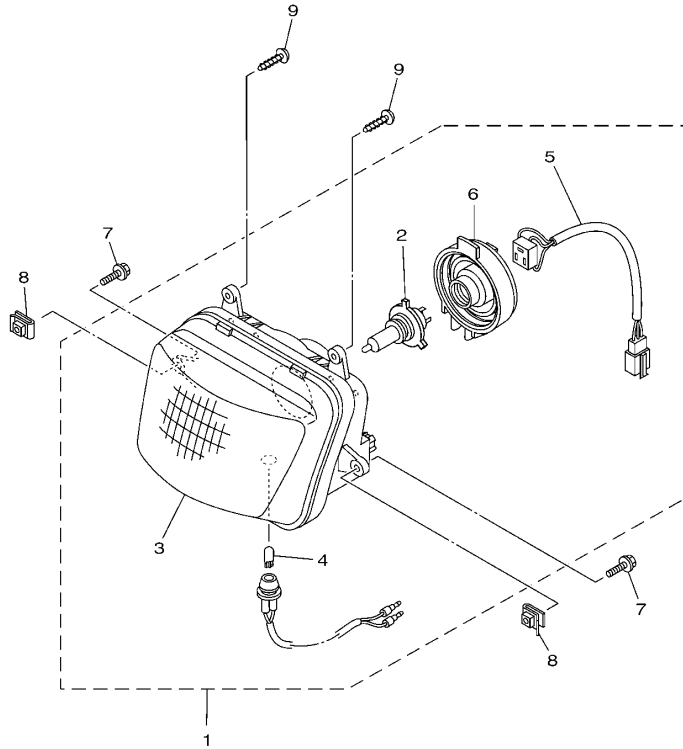

1BK3415-K460

FIG. 44 尾灯

TAILLIGHT

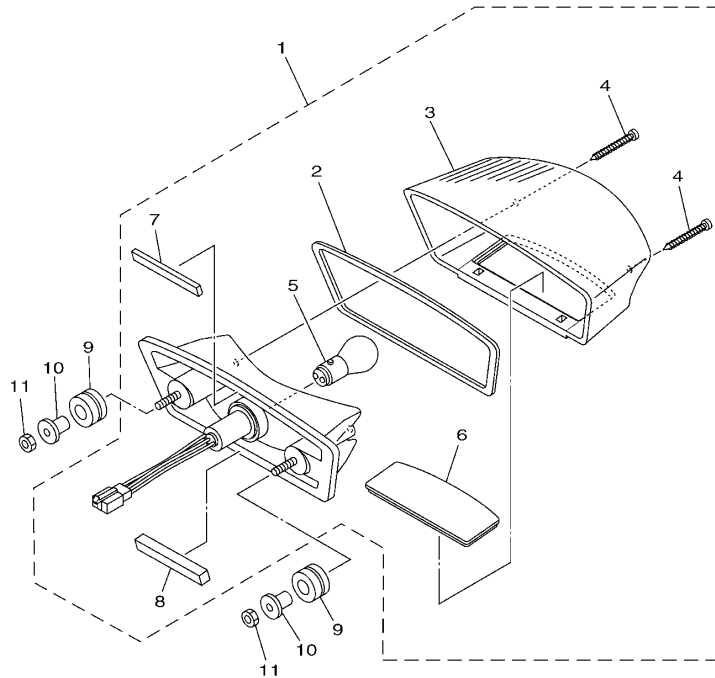

参照 号码	零件号码 PART NO.	零件名称 DESCRIPTION	1BK5	1BK6	1BK7	1BK8	备注 REMARKS
1	1BK-Y8471-00	尾灯装置组合 TAILLIGHT UNIT ASSY	1	1	1	1	
2	1BK-H4704-00	.尾灯衬垫 .GASKET, TAILLIGHT	1	1	1	1	
3	1BK-H4721-00	.尾灯透镜 .LENS, TAILLIGHT	1	1	1	1	
4	1BK-H4724-00	.镜面安装螺钉 .SCREW, LENS FITTING	2	2	2	2	
5	1BK-H4714-00	.灯泡 .BULB (12V-21/5W)	1	1	1	1	
6	1BK-H4543-00	.镜面牌照灯 .LENS, LICENCE LAMP	1	1	1	1	
7	5VL-H4753-00	.减震 .DAMPER	1	1	1	1	
8	5VL-H4736-00	.尾部减震块 1 .DAMPER, TAIL 1	1	1	1	1	
9	90480-14812	橡胶垫 GROMMET	2	2	2	2	
10	90387-06837	轴套 COLLAR	2	2	2	2	
11	95302-06600	螺母 NUT	2	2	2	2	



1BK3415-K480

FIG. 45 手柄开关(鼓刹)

SWITCH & LEVER FOR DRUM BRAKE

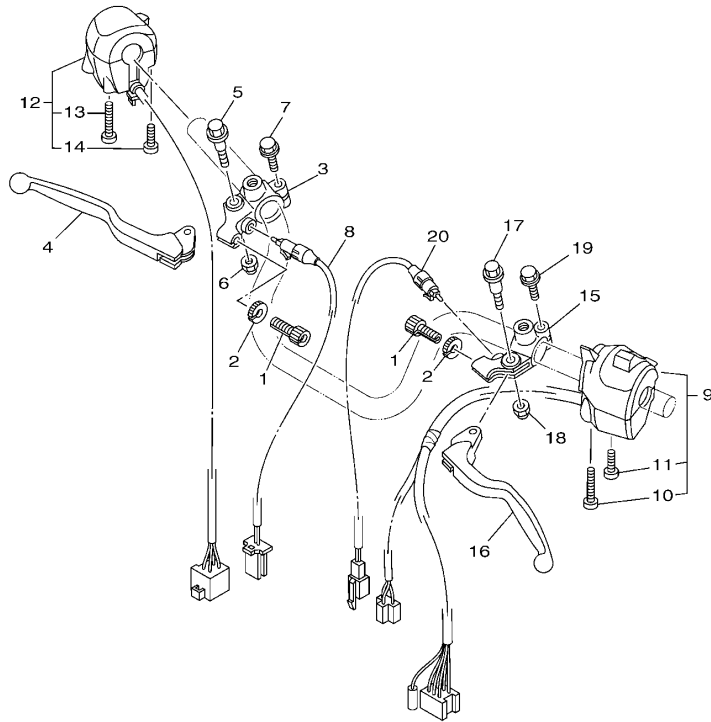

参照 号码	零件号码 PART NO.	零件名称 DESCRIPTION	1BK5	1BK6	1BK7	1BK8	备注 REMARKS
1	90123-08813	螺栓 BOLT	2	2			
2	90179-08862	螺母 NUT	2	2			
3	4FP-H2921-00	手柄座 2 HOLDER, LEVER 2	1	1			
4	5VL-H3922-00	手柄 2 LEVER 2	1	1			
5	90109-06850	螺栓 BOLT	1	1			
6	95602-06100	锁紧螺母 NUT, U	1	1			
7	97522-06525	带垫螺栓 BOLT, WITH WASHER	1	1			
8	5VL-H3980-21	前制动开关组合 FRONT STOP SWITCH ASSY	1	1			
9	1BK-H3973-00	手把开关 3 SWITCH, HANDLE 3	1	1			
10	98507-05045	. 十字螺钉 .SCREW, PAN HEAD	1	1			
11	98507-05025	. 十字螺钉 .SCREW, PAN HEAD	1	1			
12	1SF-H3975-00	手把开关 2 SWITCH, HANDLE 2	1	1			
13	98507-05050	. 十字螺钉 .SCREW, PAN HEAD	1	1			
14	98507-05030	. 十字螺钉 .SCREW, PAN HEAD	1	1			
15	4FP-H2911-00	手柄座 1 HOLDER, LEVER 1	1	1			
16	5VL-H3912-00	手柄 1 LEVER 1	1	1			
17	90109-06850	螺栓 BOLT	1	1			
18	95602-06100	锁紧螺母 NUT, U	1	1			
19	97522-06525	带垫螺栓 BOLT, WITH WASHER	1	1			
20	5VL-H2917-11	开关 SWITCH	1	1			



1BK5415-M450

FIG. 46 手柄开关(碟刹)

SWITCH & LEVER FOR DISK BRAKE

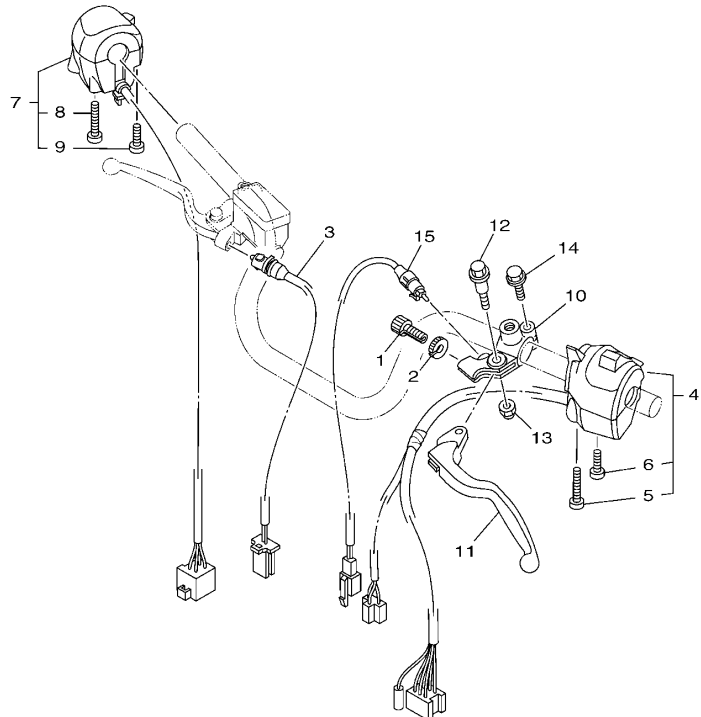

参照 号码	零件号码 PART NO.	零件名称 DESCRIPTION	1BK5	1BK6	1BK7	1BK8	备注 REMARKS
1	90123-08813	螺栓 BOLT			1	1	
2	90179-08862	螺母 NUT			1	1	
3	5VL-H3980-01	前制动开关组合 FRONT STOP SWITCH ASSY			1	1	
4	1BK-H3973-00	手把开关 3 SWITCH, HANDLE 3			1	1	
5	98507-05045	.十字螺钉 .SCREW, PAN HEAD			1	1	
6	98507-05025	.十字螺钉 .SCREW, PAN HEAD			1	1	
7	1SF-H3975-00	手把开关 2 SWITCH, HANDLE 2			1	1	
8	98507-05050	.十字螺钉 .SCREW, PAN HEAD			1	1	
9	98507-05030	.十字螺钉 .SCREW, PAN HEAD			1	1	
10	4FP-H2911-00	手柄座 1 HOLDER, LEVER 1			1	1	
11	5VL-H3912-00	手柄 1 LEVER 1			1	1	
12	90109-06850	螺栓 BOLT			1	1	
13	95602-06100	锁紧螺母 NUT, U			1	1	
14	97522-06525	带垫螺栓 BOLT, WITH WASHER			1	1	
15	5VL-H2917-11	开关 SWITCH			1	1	



1BK5415-M460

FIG. 47 电气系统 1

ELECTRICAL 1

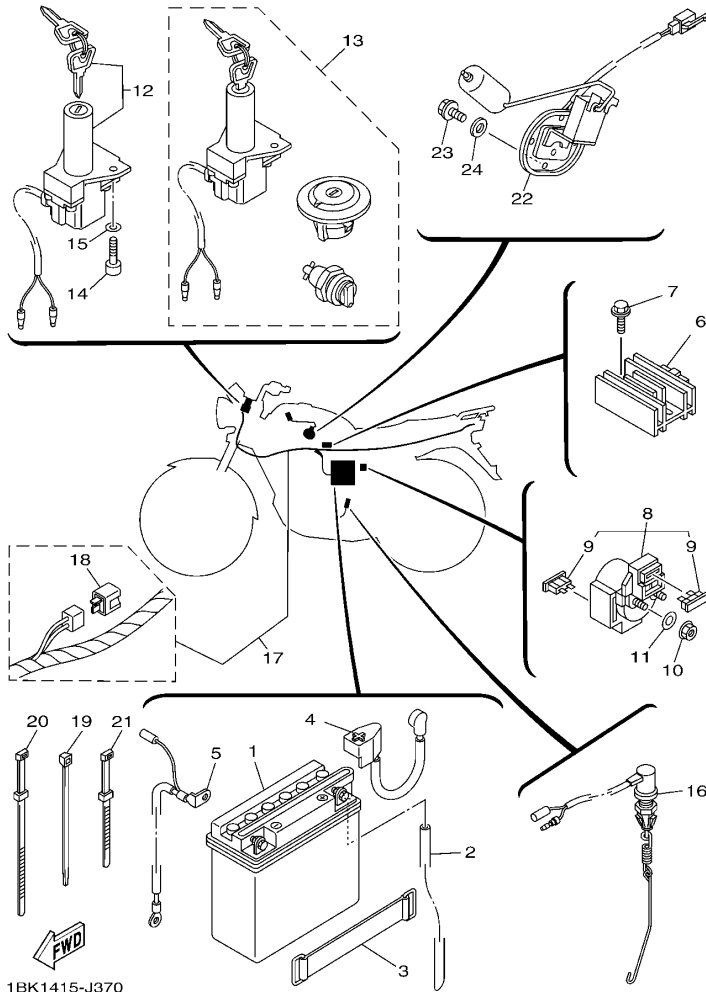

1BK1415-J370

参照 号码	零件号码 PART NO.	零件名称 DESCRIPTION	1BK5	1BK6	1BK7	1BK8	备注 REMARKS
1	1BK-H2100-00	蓄电池组合 (12N5S-3B) BATTERY ASSY (12N5S-3B)	1	1	1	1	
2	90445-08830	软管 HOSE	1	1	1	1	
3	5VL-H2131-01	蓄电池带箍 BAND, BATTERY	1	1	1	1	
4	5VL-H2115-00	正极导线 WIRE, PLUS LEAD	1	1	1	1	
5	5VL-H2116-00	负极导线 WIRE, MINUS LEAD	1	1	1	1	
6	2D0-H1960-10	整流调节器 RECTIFIER & REGULATOR ASSY	1	1	1	1	
7	95802-06020	凸缘螺栓 BOLT, FLANGE	2	2	2	2	
8	5VL-H1940-01	起动机继电器组合 STARTER RELAY ASSY	1	1	1	1	
9	4FP-H2151-00	保险丝 . FUSE (15A)	2	2	2	2	
10	95302-06600	螺母 NUT	2	2	2	2	
11	90201-068C2	平垫圈 WASHER, PLATE	2	2	2	2	
12	1BK-H2501-10	主开关方向锁组合 MAIN SWITCH STEERING LOCK	1	1			
	13R-H2501-10	主开关方向锁组合 MAIN SWITCH STEERING LOCK			1	1	
13	1BK-Y8250-10	锁总成 SWITCH ASSY	1	1			AP AP AP
	13R-Y8250-10	锁总成 SWITCH ASSY			1	1	
14	91312-06020	螺栓 BOLT	2	2	2	2	
15	90201-068C2	平垫圈 WASHER, PLATE	2	2	2	2	
16	3S9-H2530-01	制动开关总成 STOP SWITCH ASSY	1	1	1	1	
17	1BK-H2590-10	电缆总成 WIRE HARNESS ASSY	1	1	1	1	
18	5VL-H1980-10	二极管总成 . DIODE ASSY	1	1	1	1	
19	90464-35820	线夹 CLAMP	1	1	1	3	
20	5VL-H3936-00	开关导线箍带 BAND, SWITCH CORD	3	3	3	3	
21	4TU-H3936-00	开关导线箍带 BAND, SWITCH CORD	2	2	2	2	
22	1BK-H5752-00	燃油表传感装置组合 SENDER UNIT ASSY, FUEL METER	1	1	1	1	
23	95802-06014	凸缘螺栓 BOLT, FLANGE	4	4	4	4	
24	90430-05800	衬垫 GASKET	4	4	4	4	

FIG. 48 电气系统 2

ELECTRICAL 2

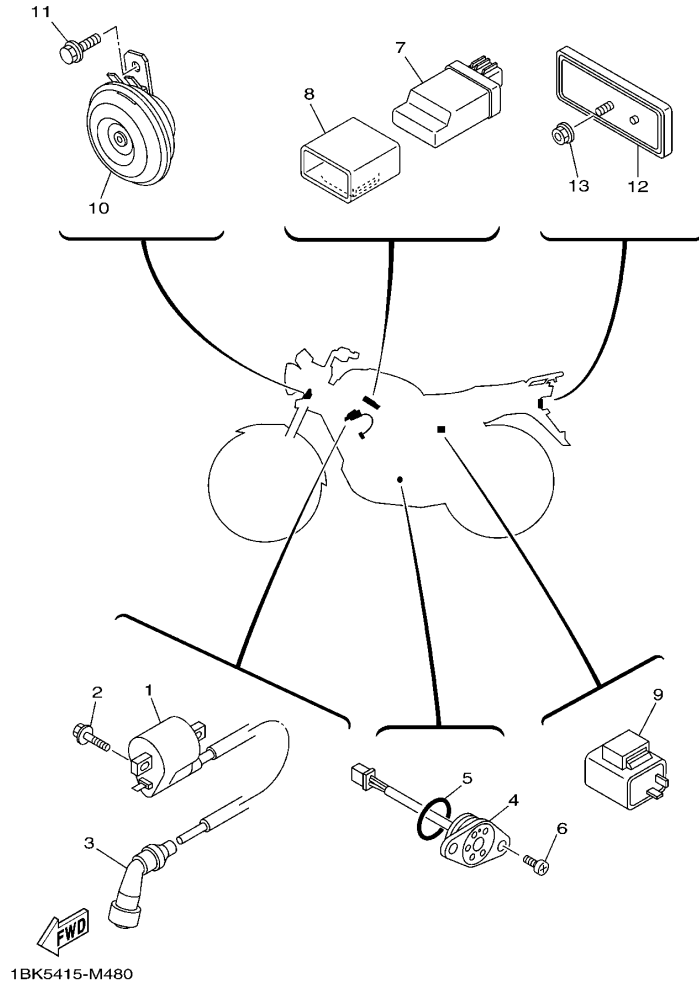

参照 号码	零件号码 PART NO.	零件名称 DESCRIPTION	1BK5	1BK6	1BK7	1BK8	备注 REMARKS
1	1BK-H2310-00	点火线圈组合 IGNITION COIL ASSY	1	1			
	1JP-H2310-00	点火线圈组合 IGNITION COIL ASSY			1	1	
2	95022-06016	凸缘螺栓 BOLT, FLANGE	2	2	2	2	
3	1BK-H2370-00	火花塞帽组合 PLUG CAP ASSY	1	1			
	1JP-H2370-00	火花塞帽组合 PLUG CAP ASSY			1	1	
4	13R-H2540-00	空挡开关组合 NEUTRAL SWITCH ASSY	1	1	1	1	
5	93210-23801	O型环 O-RING	1	1	1	1	
6	90154-05802	夹紧螺钉 SCREW, BINDING	2	2	2	2	
7	1BK-H5540-00	CDI 总成 C.D.I. UNIT ASSY	1	1			
	1JP-H5540-10	CDI 总成 C.D.I. UNIT ASSY			1	1	
8	5VL-H5546-00	箍带 BAND	1	1	1	1	
9	5VL-H3350-21	闪烁继电器组合 FLASHER RELAY ASSY	1	1	1	1	
10	1BK-H3371-10	电喇叭 HORN	1	1	1	1	
11	95822-06012	凸缘螺栓 BOLT, FLANGE	1	1	1	1	
12	4FP-H5130-21	后反射镜组合 REAR REFLECTOR ASSY	1	1	1	1	
13	95702-05500	螺母 NUT, FLANGE	1	1	1	1	

零件号码索引
NUMERICAL INDEX

零件号码 PART NO.	参照 号码	零件号码 PART NO.	参照 号码	零件号码 PART NO.	参照 号码	零件号码 PART NO.	参照 号码	零件号码 PART NO.	参照 号码	零件号码 PART NO.	参照 号码
5YY-14103-00	7 - 18	5VL-E2210-01	4 - 15	1JP-E6150-10	12 - 6	4GU-F1685-00	17 - 8	2D0-F3152-00	23 - 6	2D0-F4183-00	24 - 3
18D-14105-00	7 - 20	5VL-E2213-10	4 - 16	1JP-E6154-00	12 - 7	5VL-F1778-00	18 - 5		23 - 19	4FP-F4183-00	24 - 4
18D-14112-00	7 - 3	5VL-E2231-00	4 - 11	5VL-E6164-10	12 - 17	5VL-F177G-00	18 - 10	2D0-F3157-00	22 - 7	4FP-F4186-01	24 - 5
22F-14139-00	7 - 24	5VL-E2241-00	4 - 12	1JP-E6300-10	12 - 5	2D0-F1780-01	18 - 6		22 - 20	2D0-F4311-00	24 - 11
5P0-14141-13	7 - 6	5VL-E3300-01	5 - 1	1JP-E6321-00	12 - 9	5VL-F1780-01	18 - 6		23 - 7	52C-F4312-00	24 - 19
5P0-14142-17	7 - 22	5VL-E3324-00	5 - 10	1JP-E6324-00	12 - 10	1BK-F2110-00	19 - 1		23 - 20	52C-F4313-00	24 - 20
5HK-14147-00	7 - 10	5VL-E3325-00	5 - 2	1JP-E6333-00	12 - 12	5VL-F2141-01	19 - 3	5VL-F3165-01	20 - 12	52C-F4314-00	24 - 21
49P-14150-00	7 - 23	2D0-E3411-00	5 - 9	1JP-E6337-00	12 - 13	5VL-F2151-10	19 - 6		21 - 12	2D0-F4500-10	24 - 7
353-14186-00	7 - 11	5VL-E3451-00	5 - 11	1JP-E6351-00	12 - 11	5VL-F2210-31	19 - 9	5VL-F3170-10	22 - 5	1BK-F4610-00	24 - 10
5LW-14191-00	7 - 14	18C-E3575-01	6 - 18	5VL-E6357-01	12 - 21	5VL-F2311-00	19 - 7		22 - 18	18C-F4610-01	24 - 10
18C-14196-00	7 - 21	18C-E3586-10	6 - 2	1JP-E6371-00	12 - 8	1BK-F3102-00	22 - 1		23 - 5	1BK-F471K-01-P0	24 - 5
5YY-14197-00	7 - 13	1SF-E410A-00	7 - 16	5VL-E6381-02	12 - 22	1BK-F3102-10	23 - 1		23 - 18	1BK-F471K-01-P1	25 - 7
3G2-14231-22	7 - 9	1BK-E4410-00	6 - 5	5VL-E7121-00	13 - 3	1BK-F3103-00	22 - 14		20 - 15	1BK-F471K-01-P2	25 - 7
18C-14261-00	7 - 7	1BK-E4411-00	6 - 6	5VL-E7131-00	13 - 4	1BK-F3103-10	23 - 14		20 - 15	1BK-F472K-01-P0	25 - 8
18D-14589-10	7 - 4	1BK-E4412-00	6 - 7	5VL-E7141-00	13 - 5	1BK-F3106-00	23 - 2		21 - 15	1BK-F472K-01-P1	25 - 8
18C-1490J-00	7 - 5	2D0-E4417-00	6 - 16	5VL-E7151-00	13 - 2	5VL-F3106-50	22 - 2		20 - 17	1BK-F472K-01-P2	25 - 8
5HK-14985-00	7 - 8	2D0-E4424-00	6 - 15	5VL-E7211-00	13 - 20	1BK-F3107-00	22 - 15		21 - 17	2D0-F4730-11	25 - 1
5LW-14994-00	7 - 15	2D0-E4437-00	6 - 10	5VL-E7221-00	13 - 15	1BK-F3107-10	23 - 15	5VL-F331X-10	22 - 27	4TU-F4741-00	8 - 2
5LW-24411-00	7 - 2	2D0-E443E-00	6 - 14	5VL-E7231-00	13 - 16	1BK-F3110-00	22 - 11		23 - 27		25 - 2
5VL-E1111-11	1 - 1	2D0-E4450-00	6 - 8	5VL-E7241-00	13 - 19		22 - 24	5VL-F3346-10	22 - 29	2D0-F4796-00	25 - 6
5VL-E1111F-00	4 - 5	2D0-E4452-00	6 - 11	5VL-E7251-00	13 - 14		23 - 11		23 - 29	1BK-F4840-00	25 - 4
5VL-E1133-01	1 - 2	1BK-E4453-00	6 - 9	5VL-E7411-00	13 - 1		23 - 24	5VL-F334G-11	20 - 21	5VL-F5111-00	26 - 1
5VL-E1134-01	1 - 3	2D0-E4462-00	6 - 12	5VL-E7421-00	13 - 12	1BK-F3111-00	22 - 12	5VL-F3389-01	20 - 18	1KL-F5118-00	26 - 29
3D9-E113F-00	8 - 11	5VL-E4613-00	8 - 7	3D9-E7456-01	13 - 28		22 - 25		21 - 18		27 - 26
5VL-E1166-00	9 - 4	1SF-E4710-01	8 - 1	5VL-E7471-00	13 - 10		23 - 12	4FP-F3395-10	20 - 20	4GU-F5118-00	28 - 12
4FP-E1167-00	9 - 3	1SF-E4758-01	8 - 3	5VL-E8101-12	15 - 7		23 - 25	4FP-F3411-00	20 - 2	4GU-F511X-01	28 - 10
1BK-E1181-00	1 - 15	13R-E4803-00	8 - 20	5VL-E8110-12	15 - 9	1BK-F3118-00	22 - 9		21 - 2	1BK-F5121-00-33	27 - 5
5VL-E1185-10	1 - 7	5VL-E4815-00	8 - 12	1KL-E8113-00	15 - 10		22 - 22	4FP-F3411-30	22 - 28	1BK-F5121-00-35	26 - 5
5VL-E1186-00	1 - 10	18C-E4873-00	8 - 17	5VL-E8140-00	15 - 1		23 - 9		23 - 28	1BK-F5135-00	26 - 9
1BK-E1310-00	1 - 18	3D9-E4881-00	8 - 14	4FP-E8177-00	15 - 3		23 - 22	1KL-F3412-00	20 - 1		27 - 9
5VL-E1351-10	1 - 19	1BK-E4882-00	8 - 19	1BK-E8185-00	14 - 5	5VL-F3141-50	22 - 8		21 - 1	1KL-F5136-00	26 - 10
5VL-E1422-00	2 - 6	3D9-E4883-00	8 - 22	5VL-E8337-00	15 - 2		22 - 21	4FP-F3412-00	20 - 3		27 - 10
5VL-E1454-00	2 - 8	1SF-E4901-01	7 - 1	2D0-E8511-00	14 - 7		23 - 8		21 - 3	1KL-F5137-01	26 - 30
5VL-E1631-00	2 - 11	5VL-E5191-00	10 - 8	2D0-E8512-00	14 - 8		23 - 21	4GU-F3416-00	20 - 5		27 - 27
5VL-E1633-00	2 - 12	5VL-E5362-00	10 - 17	2D0-E8513-00	14 - 9	4GU-F3144-10	22 - 4		21 - 5	1KL-F5138-00	26 - 11
5VL-E1651-00	2 - 5	1SF-E5411-00	10 - 1	5VL-E8531-00	14 - 10		22 - 17	5VL-F3418-01	20 - 7		27 - 11
5VL-E1681-00	2 - 3	1BK-E5418-10	10 - 10	5VL-E8535-00	14 - 11		23 - 4		21 - 7	1KL-F5149-01	26 - 15
1BK-E2111-00	3 - 1	1BK-E5421-00	10 - 12	1SF-E8541-00	14 - 1		23 - 17	5VL-F341E-00	20 - 4		27 - 15
1SF-E2113-00	3 - 5	5VL-E5441-01	9 - 11	1JD-E8542-00	14 - 2	1BK-F3145-00	22 - 3		21 - 4	4FP-F5155-11	26 - 17
5VL-E2216-01	3 - 4	5VL-E5451-10	10 - 2	1BK-F1110-11	16 - 1		22 - 16	5VL-F3435-00-35	20 - 9		27 - 17
5VL-E2217-01	3 - 7	5VL-E5461-10	10 - 13	1BK-F1316-00	16 - 2		23 - 3		21 - 9	1BK-F5168-00-33	27 - 1
5VL-E2218-00	3 - 6	5VL-E5512-00	11 - 3	5VL-F1317-00	16 - 7		23 - 16	3S9-F3441-00	20 - 13	1BK-F5168-10-33	28 - 1
1BK-E2219-00	3 - 3	5VL-E5517-00	11 - 7	5VL-F1318-00	16 - 8	2D0-F3146-00	22 - 10		21 - 13	5VL-F5181-01	26 - 28
1BK-E22121-00	3 - 2	5VL-E5521-00	11 - 4	5VL-F1518-01	17 - 3		22 - 23	4S0-F4135-00	24 - 18		27 - 25
5VL-E22151-00	3 - 8	5VL-E5532-00	11 - 5	5VL-F1535-01	36 - 9		23 - 10	1BK-F4170-00	24 - 13	5VL-F5181-11	28 - 7
5VL-E22156-00	3 - 10	1BK-E5580-00	11 - 9		43 - 8		23 - 23	2D0-F4176-01	24 - 6	4GU-F5190-12	28 - 8
1BK-E22171-00	4 - 1	5VL-E5598-00	4 - 13	1BK-F1611-00	17 - 6	2D0-F3152-00	22 - 6	1BK-F4180-01	24 - 14	5VL-F5311-00	30 - 1
5VL-E2176-00	4 - 7	1JP-E6111-00	12 - 1	5VL-F1621-00	17 - 12		22 - 19	4FP-F4181-00	24 - 2	1BK-F5321-00-33	31 - 8

零件号码索引
NUMERICAL INDEX

零件号码 PART NO.	参照 号码	零件号码 PART NO.	参照 号码	零件号码 PART NO.	参照 号码	零件号码 PART NO.	参照 号码	零件号码 PART NO.	参照 号码	零件号码 PART NO.	参照 号码
1BK-F5321-00-35	30 - 8	1SF-F5896-00	34 - 3	13R-H1410-00	37 - 2	5VL-H3321-00	40 - 9	1SF-H3975-00	46 - 7	1BK-W2411-01-P0	24 - 1
1BK-F5338-00-33	31 - 5	4S9-F589F-00	34 - 9	1SF-H1410-20	37 - 2	1BK-H3330-00	39 - 12	5VL-H3980-01	46 - 3	1BK-W2411-01-P1	24 - 1
4GU-F533A-01	26 - 22	1SF-F589H-00	34 - 7	1BK-H1450-00	37 - 1	1BK-H3330-10	40 - 10	5VL-H3980-21	45 - 8	1BK-W2411-01-P2	24 - 1
	27 - 22	4S9-F5917-00	29 - 12	1SF-H1450-20	37 - 1	1BK-H3333-00	39 - 4	5VL-H4145-40	42 - 11	5VL-W2533-21	26 - 6
	30 - 16	4S9-F5919-00	29 - 11	1BK-H1800-10	38 - 1		39 - 9	5VL-H4163-40	42 - 10		27 - 6
	31 - 16	1SF-F5921-00	29 - 8	2D0-H1801-00	38 - 2		39 - 15	5VL-H4164-40	42 - 9		30 - 9
4GU-F5351-02	26 - 20	4S9-F5924-01	29 - 13	2D0-H1828-00	38 - 5		39 - 20	5VL-H4300-51	42 - 1		31 - 9
	27 - 20	4S9-F5925-11	29 - 14	1BK-H183G-00	38 - 7	1BK-H333A-10	40 - 4	5VL-H4310-31	43 - 1	1BK-W2835-01-P0	36 - 1
	30 - 12	4S9-F5937-00	29 - 9	5VL-H1940-01	47 - 8		40 - 15	5VL-H4310-50	42 - 5	1BK-W2835-01-P1	36 - 1
	31 - 12	4S9-F5939-00	29 - 10	2D0-H1960-10	47 - 6	1BK-H3340-00	39 - 17	5VL-H4311-51	42 - 7	1BK-W2835-01-P2	36 - 1
5VL-F5355-01	30 - 13	13R-F6111-00	32 - 1	5VL-H1980-10	47 - 18	1BK-H3340-10	40 - 14	13R-H4314-00	42 - 2	5VL-W5304-01	26 - 23
	31 - 13		33 - 1	1BK-H2100-00	47 - 1	1BK-H334A-10	40 - 8	5VL-H4314-10	43 - 2		30 - 25
1KL-F5364-00	30 - 4	1SF-F6240-00	32 - 2	5VL-H2109-00	35 - 16		40 - 11	5VL-H4321-50	42 - 4	1BK-W8381-00	36 - 2
	31 - 4		33 - 2	5VL-H2115-00	47 - 4	5VL-H3350-21	48 - 9	5VL-H4330-31	43 - 3	5VL-Y1153-00	2 - 7
5VL-F5366-00	30 - 17	5VL-F6241-00	32 - 3	5VL-H2116-00	47 - 5	5VL-H3359-01	39 - 22	4GU-H4347-10	42 - 3	5VL-Y1215-00	3 - 9
	31 - 17		33 - 3	5VL-H2131-01	47 - 3		40 - 18		43 - 4	5VL-Y1635-10	12 - 14
5VL-F5371-00	30 - 30	13R-F6280-00	32 - 9	4FP-H2151-00	47 - 9	1BK-H3371-10	48 - 10	5VL-H4359-30	43 - 5	1BK-Y2151-00-P0	17 - 1
	31 - 27		33 - 6	1BK-H2310-00	48 - 1	1BK-H338B-00	39 - 5	5VL-H4375-40	42 - 6	1BK-Y2151-00-P1	17 - 1
5VL-F5377-01	30 - 38	13R-F6290-00	32 - 10	1JP-H2310-00	48 - 1		39 - 10	5VL-H4378-30	43 - 6	1BK-Y2151-00-P2	17 - 1
	31 - 35		33 - 7	1BK-H2370-00	48 - 3		39 - 16	1BK-H4526-00	42 - 8	1BK-Y2171-01-P0	18 - 1
5VL-F5381-01	30 - 35	2D0-F6311-01	32 - 13	1JP-H2370-00	48 - 3		39 - 21	1BK-H4543-00	44 - 6	1BK-Y2171-02-P0	18 - 1
	31 - 32		33 - 8	13R-H2501-10	47 - 12	1BK-H338B-10	40 - 3	1BK-H4704-00	44 - 2	1BK-Y2171-03-P0	18 - 1
5VL-F5386-01	30 - 37	2D0-F6312-01	32 - 15	1BK-H2501-10	47 - 12		40 - 7	1BK-H4714-00	44 - 5	1BK-Y2172-01-P0	18 - 3
	31 - 34		33 - 10	3S9-H2530-01	47 - 16		40 - 12	1BK-H4721-00	44 - 3	1BK-Y2172-02-P0	18 - 3
5VL-F5387-01	30 - 20	1SF-F6331-00	32 - 16	13R-H2540-00	48 - 4		40 - 16	1BK-H4724-00	44 - 4	1BK-Y2172-03-P0	18 - 3
	31 - 20		33 - 11	1BK-H2590-10	47 - 17	1BK-H3500-40	41 - 1	5VL-H4736-00	44 - 8	13R-Y8250-10	47 - 13
5VL-F5388-01	30 - 39	5VL-F6335-11	32 - 4	4FP-H2911-00	45 - 15	13R-H3509-00	41 - 10	5VL-H4753-00	44 - 7	1BK-Y8250-10	47 - 13
	31 - 36		33 - 4		46 - 10	5VL-H350E-00	41 - 12	5VL-H5110-20	22 - 13	1BK-Y8471-00	44 - 1
5VL-F53C0-10	30 - 42	5VL-F6341-11	32 - 6	5VL-H2917-11	45 - 20	4FP-H3517-10	41 - 11		22 - 26	90101-06848	26 - 18
	31 - 39	5VL-F6372-01	32 - 5		46 - 15	13R-H3524-00	41 - 8		23 - 13		27 - 18
5LK-F5412-01	30 - 23		32 - 7	4FP-H2921-00	45 - 3	13R-H353G-00	41 - 5		23 - 26		30 - 14
	31 - 23		33 - 5	1BK-H3310-00	39 - 1	18C-H353H-00	41 - 14	4FP-H5130-21	48 - 12		31 - 14
5VL-F5445-01	30 - 21	1BK-F7111-00	35 - 1	1BK-H3310-10	40 - 1	5VL-H353S-00	41 - 7	1BK-H5540-00	48 - 7	90101-08820	4 - 9
	31 - 21	2D0-F7112-02	35 - 2	4FP-H3311-00	39 - 2	5VL-H3543-00	41 - 13	1JP-H5540-10	48 - 7	90105-08724	1 - 12
1SF-F580U-00	29 - 3	5VL-F7115-01	35 - 3		39 - 7	1BK-H354P-00	41 - 9	5VL-H5546-00	48 - 8	90105-08873	16 - 12
1BK-F582U-00	29 - 1	1SF-F7211-00	35 - 7		39 - 13	5VL-H3550-12	41 - 17	1BK-H5752-00	47 - 22	90105-08874	16 - 4
1SF-F583T-00	34 - 1	5VL-F7231-01	35 - 9		39 - 18	5VL-H3550-23	41 - 17	1BK-HA251-40	41 - 2	90105-088E4	16 - 9
1SF-F5852-00	34 - 6	5VL-F7311-00	35 - 19	4GU-H3311-10	40 - 2	5VL-H357H-00	41 - 15	1BK-HA252-40	41 - 3	90105-088E5	16 - 10
1SF-F5854-00	34 - 4	1SF-F7411-00	35 - 15		40 - 6	13R-H358L-00	41 - 6	13R-HA253-00	41 - 4	90105-088E6	16 - 13
1SF-F585B-00	34 - 5	5VL-F7413-00	35 - 17		40 - 13	5VL-H3912-00	45 - 16	1SF-W0041-00	34 - 2	90105-10831	29 - 15
1SF-F5865-00	34 - 12	47V-F7431-01	35 - 26		40 - 17		46 - 11	4S9-W0045-00	29 - 6	90109-06822	17 - 2
1SF-F5867-00	34 - 11	4FP-F7433-00	35 - 27	1BK-H3312-00	39 - 3	1SF-H3922-00	34 - 8	4S9-W0047-00	29 - 5	90109-06850	45 - 5
4S9-F586F-00	34 - 10	1BK-F7452-00	35 - 23		39 - 8	5VL-H3922-00	45 - 4	4S9-W0048-01	29 - 7		45 - 17
5VL-F5872-11	34 - 13	2D0-F7462-20	35 - 24		39 - 14	4TU-H3936-00	47 - 21	4S9-W0057-00	29 - 4		46 - 12
5VL-F5875-01	34 - 18	5VL-F8100-10	16 - 15		39 - 19	5VL-H3936-00	47 - 20	5VL-W1140-20	2 - 1	90109-08847	30 - 31
5VL-F5876-00	34 - 19	5VL-F811G-01	16 - 16	1BK-H3320-00	39 - 6	1BK-H3973-00	45 - 9	5VL-W1141-00	2 - 2		31 - 28
5VL-F5886-00	34 - 17	5VL-F8215-01	36 - 5	1BK-H3320-10	40 - 5		46 - 4	5VL-W1161-00	2 - 14	90109-08848	30 - 32
5VL-F5887-00	34 - 16	1BK-H1168-00	38 - 4	5VL-H3321-00	39 - 11	1SF-H3975-00	45 - 12	1SF-W1510-00	9 - 1		31 - 29

零件号码索引
NUMERICAL INDEX

零件号码 PART NO.	参照 号码	零件号码 PART NO.	参照 号码	零件号码 PART NO.	参照 号码	零件号码 PART NO.	参照 号码	零件号码 PART NO.	参照 号码	零件号码 PART NO.	参照 号码
90109-08864	30 - 22	90201-068C2	47 - 15	90388-14800	19 - 2	90560-15293	28 - 2	93306-003YS	4 - 2	95022-06016	41 - 16
	31 - 22	90201-07641	5 - 4	90401-10811	34 - 14	91312-05010	13 - 29	93306-054X3	30 - 18		48 - 2
90109-10849	35 - 21	90201-07836	26 - 13	90430-05800	24 - 9	91312-06012	4 - 6		31 - 18	95022-06020	1 - 9
90111-08805	29 - 2		27 - 13		47 - 24	91312-06014	37 - 4	93306-201YD	13 - 8	95022-06025	34 - 21
90119-06811	17 - 9	90201-08326	4 - 8	90430-06817	1 - 6	91312-06016	8 - 13	93306-202XN	2 - 15		38 - 8
	18 - 11	90201-08830	42 - 13		4 - 18	91312-06020	6 - 4	93306-203YT	13 - 9	95022-06030	9 - 7
90119-06869	6 - 17	90201-08840	8 - 10	90430-12227	5 - 8		8 - 8	93306-204XD	13 - 24	95022-06035	10 - 4
	17 - 7	90201-088C3	1 - 13	90445-08830	47 - 2		47 - 14	93306-205YP	2 - 10		10 - 15
	25 - 3	90201-108C7	19 - 10	90450-44804	6 - 1	91312-06025	37 - 3	93306-252XA	30 - 6	95022-06045	9 - 8
	25 - 9		26 - 33	90462-16801	9 - 6	91312-06090	1 - 17		31 - 3		10 - 16
90123-08813	45 - 1		27 - 30	90464-12803	17 - 10	91312-08016	11 - 10	93306-252XH	13 - 26	95022-06050	10 - 5
	46 - 1	90201-108J9	34 - 15	90464-16804	17 - 11	91402-16012	35 - 30	93306-252YY	28 - 4	95022-06055	9 - 9
90149-05800	36 - 3	90201-122H1	2 - 17	90464-35820	47 - 19	91402-20012	30 - 34		30 - 3	95022-08035	20 - 14
90151-06818	14 - 4		12 - 3	90467-07029	24 - 23		31 - 31		31 - 2		21 - 14
90153-06803	1 - 5	90201-14809	19 - 5	90467-09006	24 - 22		35 - 10	93306-301XS	26 - 4	95022-08040	20 - 10
90153-08804	30 - 41	90201-15700	13 - 21	90467-09854	24 - 12	91402-30025	35 - 6		27 - 3		21 - 10
	31 - 38	90201-15815	35 - 5	90467-12828	9 - 5	92012-06012	8 - 21	93310-629Y3	2 - 4	95023-08030	42 - 12
90154-05802	48 - 6	90201-20266	13 - 6	90467-14802	8 - 23	92902-06200	12 - 15	93410-19831	26 - 16	95302-06600	12 - 16
90155-06800	5 - 6		13 - 17	90467-16807	8 - 15		35 - 11		27 - 16		26 - 19
90159-06820	24 - 8	90201-20272	13 - 23	90467-18806	8 - 18	93101-10800	10 - 19	93410-20809	13 - 7		27 - 19
90159-06830	19 - 8	90201-20844	26 - 14	90467-19801	8 - 16	93101-12803	15 - 4		13 - 18		30 - 15
90170-12060	12 - 19		27 - 14	90480-01868	25 - 10	93102-12812	12 - 24	93440-10109	1 - 4		31 - 15
90176-10810	19 - 11	90201-208D4	35 - 28	90480-13018	24 - 15	93102-18804	26 - 3	93450-16812	2 - 13		44 - 11
90176-22802	20 - 11	90201-228F6	18 - 7	90480-13837	18 - 4		27 - 4	93503-16824	12 - 20		47 - 10
	21 - 11	90201-258D7	11 - 8	90480-14812	44 - 9	93102-20812	13 - 25	93604-10837	14 - 6	95302-08800	42 - 14
90179-06826	32 - 12	90202-26142	20 - 8	90480-20M05	8 - 24	93102-20857	28 - 3	93608-30839	15 - 8	95312-08600	30 - 40
	35 - 14		21 - 8	90480-24186	18 - 2	93104-07800	26 - 12	93822-14813	13 - 27		31 - 37
90179-08639	30 - 24	90208-07052	5 - 5	90501-06805	14 - 3		27 - 12	94109-18814	30 - 28	95602-06100	45 - 6
	31 - 24	90215-12211	12 - 18	90501-08803	32 - 8	93104-22802	30 - 7		31 - 25		45 - 18
90179-08830	16 - 6	90240-06806	35 - 29	90501-10806	35 - 12		31 - 6	94127-18845	26 - 26		46 - 13
	16 - 11	90249-12808	32 - 11	90506-12801	26 - 7	93105-47808	26 - 21		27 - 23	95602-12200	19 - 4
	16 - 14		35 - 13		27 - 7		27 - 21		28 - 5	95602-14200	28 - 13
	45 - 2	90280-03017	2 - 16		30 - 10		28 - 9	94209-18801	30 - 29		30 - 36
	46 - 2	90282-05001	12 - 2		31 - 10	93106-26812	30 - 19		31 - 26		31 - 33
90179-10807	16 - 5	90331-07031	13 - 13	90506-15802	26 - 8		31 - 19	94227-18818	26 - 27	95702-05500	36 - 4
90179-12813	12 - 4	90340-12097	5 - 7		27 - 8	93210-11809	2 - 9		27 - 24		48 - 13
90179-12863	2 - 18	90340-14810	10 - 6		30 - 11	93210-14817	10 - 7		28 - 6	95702-08500	30 - 33
90179-25806	20 - 6	90387-06737	24 - 16		31 - 11	93210-14818	26 - 31	94327-18800	26 - 25		31 - 30
	21 - 6	90387-06837	44 - 10	90506-29800	35 - 20		27 - 28		30 - 27	95702-10500	19 - 12
90183-05807	25 - 12	90387-07818	17 - 4	90506-32800	35 - 4	93210-19809	10 - 18	94416-18803	26 - 24		39 - 23
90185-10807	26 - 32		36 - 7	90508-16800	12 - 23	93210-23801	48 - 5	94418-18802	30 - 26		40 - 19
	27 - 29	90387-12840	26 - 34	90508-32801	15 - 5	93210-30801	6 - 3	94568-C1088	4 - 10	95802-06014	47 - 23
	35 - 22		27 - 31	90508-40801	35 - 8	93210-42803	30 - 5	94668-E2001	30 - 43	95802-06016	36 - 8
90201-05802	20 - 23	90387-15803	11 - 1	90520-10812	36 - 12	93210-42807	31 - 7		31 - 40		36 - 10
90201-05803	8 - 5	90387-15809	30 - 2	90520-20808	36 - 6	93210-44812	1 - 11	94700-00869	1 - 14	95802-06020	4 - 14
90201-05804	8 - 6		31 - 1	90520-20809	36 - 11	93210-54807	38 - 3	95022-06016	4 - 17		43 - 7
90201-06850	18 - 9	90387-158K1	28 - 11	90560-12828	26 - 2	93210-79802	1 - 8		24 - 17		47 - 7
90201-068C2	47 - 11	90387-167L5	4 - 3		27 - 2	93306-002YM	4 - 4		34 - 20	95812-08016	25 - 5

零件号码索引
NUMERICAL INDEX

零件号码 PART NO.	参照 号码	零件号码 PART NO.	参照 号码	零件号码 PART NO.	参照 号码	零件号码 PART NO.	参照 号码	零件号码 PART NO.	参照 号码	零件号码 PART NO.	参照 号码
95812-08020	8 - 9										
	35 - 18										
	35 - 25										
95812-10080	16 - 3										
95822-06012	20 - 19										
	21 - 19										
	48 - 11										
95822-06016	17 - 5										
	20 - 16										
	21 - 16										
97002-05012	20 - 22										
97022-06020	15 - 11										
97522-06525	45 - 7										
	45 - 19										
	46 - 14										
97602-06220	6 - 13										
97702-50012	25 - 11										
97702-50020	43 - 9										
98502-05010	32 - 14										
	33 - 9										
98507-04008	7 - 12										
98507-04014	7 - 19										
98507-05008	7 - 17										
98507-05025	45 - 11										
	46 - 6										
98507-05030	45 - 14										
	46 - 9										
98507-05045	45 - 10										
	46 - 5										
98507-05050	45 - 13										
	46 - 8										
98512-06010	10 - 9										
	11 - 6										
	13 - 11										
98902-05008	38 - 6										
98902-06016	10 - 11										
98902-06020	18 - 8										
98980-06012	8 - 4										
99002-05600	5 - 3										
99002-10600	15 - 6										
99009-15400	11 - 2										
	13 - 22										
99009-20500	12 - 25										
99530-10114	1 - 16										
	9 - 2										
	9 - 10										
	10 - 3										
	10 - 14										

雅马哈纯正机油大集结



纯正机油

品质保证! 动力之源!

请经销YAMALUBE纯正 机油!



90793-AC421-T1
90793-AC421-G1
SAE 10W-40 (1L)
高等级/通用



90793-AC432-00
SAE 10W-30 (1L)
通用机油



90793-AC423-T1
90793-AC423-G1
SAE 20W-40 (1L)
跨骑车专用



90793-AC427-T1
90793-AC427-G1
SAE 10W-40 (0.8L)
弯梁车专用



90793-AC426-T1
SAE 5W-30 (1L)
冬季专用/通用



90793-AC434-00
SAE 10W-30 (0.8L)
弯梁车专用



90793-AC425-T1
90793-AC425-G1
SAE 20W-40 (1L)
踏板车专用



90793-AC404
GEAR (0.13L)
齿轮油
踏板车专用

友情提示：磨合期后，建议每1500KM更换一次机油(可根据实际使用状况减少里程数)。并清洗机油滤网。