

翻印必究



SHANGHAI YAMAHA JIANSHE MOTOR MARKETING CO., LTD.

# 零件目录

XA100(1CCB)  
XA100(1CCC)

1CC-F8198-1M-MA

1M1CC-415MA

## 凌鹰100



XA100(1CCB/1CCC)



上海雅马哈建设摩托车销售有限公司

<http://www.yamaha-motor.com.cn/>

第一版 2013年2月



1CCB(手鼓)

代号	颜色
0903	金属黑



代号	颜色
0918	深金属红



代号	颜色
00UG	亮丽褐色



代号	颜色
0776	紫灰金属蓝3



代号	颜色
0233	金属白1



1CCC(脚鼓)

代号	颜色
0903	金属黑



代号	颜色
0918	深金属红



代号	颜色
00UG	亮丽褐色



代号	颜色
0776	紫灰金属蓝3



代号	颜色
0233	金属白1





# 前言

本零件目录记载着封面页所示型号所使用的零件。当您订购更换零件时，请参阅本零件目录并正确指示零件号码和零件名称。

1. 零件目录发行后有变更或附加零件时，将会以雅马哈零件信息通知大家。  
建议您应按照雅马哈零件信息修改本零件目录。

2. 省略记号  
本文中所记载的省略记号的意思如下。

“UR” 需要指定的零件号码。

“UN” 需要数。

“AP” 选购品

“LM” 当地制造（必需于当地订购的零件）

“F#” 车架号（适用的机器号）

“O/S” 超过尺寸

3. 组件中部件的数量

- 组件的销售零件，如下所示，在零件名称的前面加上（.）的记号来表示。
- 每个部件右侧的数字表示各组件单体内该部件的数量。

零件号码	零件名称	数量	备注
2F5 - 83310 - 60	前闪光灯组合	2	
115 - 83311 - 60	. 灯泡 (6V - 18W)	1	

4. 适用的图形颜色表示在“备注”中，如下所示。

零件号码	零件名称	数量	备注
2N4 - 24110 - 00 - X5	燃油箱组件	2	MXR
3J1 - 24240 - 10	. 燃油箱图形	1	适用于 MXR

5. 请注意插图只用于找寻零件号码时参照，并不适用于组装。组装时，请使用适用的维修手册。

6. 在参照号码前的星号（\*）表示其为在第一版后更改的项目。



# 前言

## 7. 适用的系列号码

车架系列号

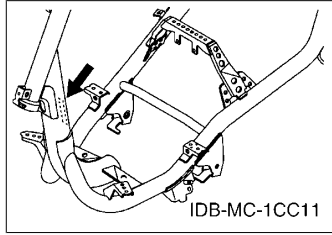

发动机系列号码

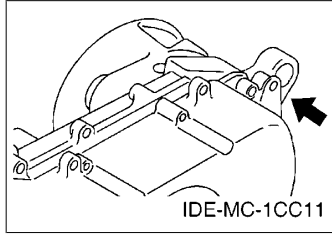

## 8. 适用的颜色记号 (\*标志表示型号颜色。)

省略记号	颜色名称 (英文)	颜色名称	颜色记号
DRMK (*)	DEEP RED METALLIC K	浓红	0918
IPB (*)	IMPERIAL BROWN	棕色	00UG
PPBM3 (*)	PALE PURPLISH BLUE METALLIC 3	发紫浅蓝 3	0776
SL	SILVER	银色	0035
SMX (*)	BLACK METALLIC X	金属黑色	0903
WM1 (*)	WHITE METALLIC 1	金属白	0233

## 9. 适用的初始系列号码

车架系列号

系列号码	数量栏名称	型号记号

发动机系列号码

系列号码	数量栏名称	型号记号

## 型号信息

### 10. 颜色信息

型号代码	颜色类型代码	颜色记号	颜色名称 (英文)	颜色名称	省略记号
1CCB	A	0903	BLACK METALLIC X	金属黑色	SMX
	B	0918	DEEP RED METALLIC K	浓红	DRMK
	C	00UG	IMPERIAL BROWN	棕色	IPB
	D	0776	PALE PURPLISH BLUE METALLIC 3	发紫浅蓝 3	PPBM3
	E	0233	WHITE METALLIC 1	金属白	WM1
1CCC	A	0903	BLACK METALLIC X	金属黑色	SMX
	B	0918	DEEP RED METALLIC K	浓红	DRMK
	C	00UG	IMPERIAL BROWN	棕色	IPB
	D	0776	PALE PURPLISH BLUE METALLIC 3	发紫浅蓝 3	PPBM3
	E	0233	WHITE METALLIC 1	金属白	WM1



# 目录

## 发动机

气缸头.....	1
曲柄·活塞.....	3
凸轮轴·链条.....	4
空气罩&风扇.....	5
油泵.....	6
进气门.....	7
化油器.....	8
排气装置.....	9
曲轴箱.....	10
起动机.....	12
离合器.....	13
传动.....	15

## 车体

车架.....	16
挡泥板.....	17
侧盖.....	18
后悬挂.....	19
前叉.....	20
油箱.....	22
座位.....	24
前轮.....	25
后轮.....	27
操纵手柄·钢索.....	28
搁脚·支架.....	30
搁脚·支架 2.....	32
护腿.....	34
发电机.....	36
起动机.....	37
转向灯.....	38
仪表.....	39
前大灯.....	40
尾灯.....	41
手柄开关·杆.....	42
电气系统 1.....	43
电气系统 2.....	44

## 索引

零件号码索引.....	45
-------------	----

# CONTENTS

## ENGINE

CYLINDER HEAD.....	1
CRANKSHAFT & PISTON.....	3
CAMSHAFT & CHAIN.....	4
AIR SHROUD & FAN.....	5
OIL PUMP.....	6
INTAKE.....	7
CARBURETOR.....	8
EXHAUST.....	9
CRANKCASE.....	10
STARTER.....	12
CLUTCH.....	13
TRANSMISSION.....	15

## CHASSIS

FRAME.....	16
FENDER.....	17
SIDE COVER.....	18
REAR SUSPENSION.....	19
FRONT FORK.....	20
FUEL TANK.....	22
SEAT.....	24
FRONT WHEEL.....	25
REAR WHEEL.....	27
STEERING HANDLE & CABLE.....	28
STAND & FOOTREST.....	30
STAND & FOOTREST 2.....	32
LEG SHIELD.....	34
GENERATOR.....	36
STARTING MOTOR.....	37
FLASHER LIGHT.....	38
METER.....	39
HEADLIGHT.....	40
TAILLIGHT.....	41
HANDLE SWITCH & LEVER.....	42
ELECTRICAL 1.....	43
ELECTRICAL 2.....	44

## INDEX

NUMERICAL INDEX.....	45
----------------------	----

FIG. 1 气缸头

CYLINDER HEAD

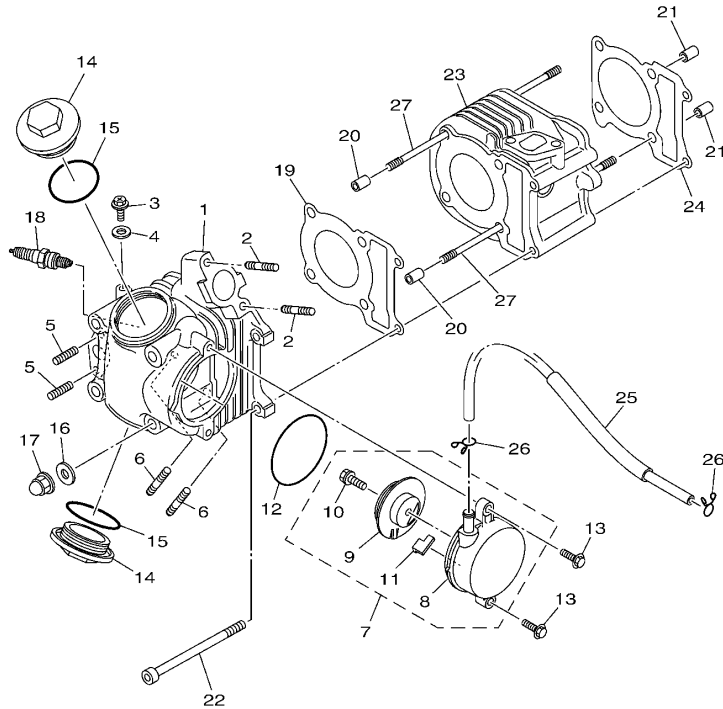

  
1CC7415-M010

参照 号码	零件号码 PART NO.	零件名称 DESCRIPTION	TCB	TC	备注 REMARKS
1	1CC-E1111-10	气缸头 1 HEAD, CYLINDER 1	1		
	1CC-E1111-00	气缸头 1 HEAD, CYLINDER 1		1	
2	1CC-E4651-00	螺栓 BOLT	2	2	
3	90153-06803	六角头螺钉 SCREW, HEXAGON	1	1	
4	90430-06014	衬垫 GASKET	1	1	
5	90113-06804	离合杆螺栓 BOLT, SET	2	2	
6	90116-06820	双头螺栓 BOLT, STUD	2	2	
7	1CC-E1160-01	通气管组合 BREATHER ASSY	1	1	
8	1CC-E1185-00	气缸头侧盖 3 COVER, CYLINDER HEAD SIDE 3	1	1	
9	1CC-E1165-00	通气管面板 PLATE, BREATHER	1	1	
10	97522-06512	带垫螺栓 BOLT, WITH WASHER	1	1	
11	1CC-E1155-00	曲折环式密封圈 SEAL, LABYRINTH	1	1	
12	93210-62802	O型环 O-RING	1	1	
13	95022-06020	凸缘螺栓 BOLT, FLANGE	2	2	
14	4KL-E1186-00	气缸头侧盖 2 COVER, CYLINDER HEAD SIDE 2	2	2	
15	93210-44808	O型环 O-RING	2	2	
16	90201-08827	平垫圈 WASHER, PLATE	4	4	
17	90176-08811	盖型螺母 NUT, CROWN	4	4	
18	94700-00869	火花塞 PLUG SPARK (NGK CR6HSA)	1	1	
19	1CC-E1181-00	气缸头衬垫 1 GASKET, CYLINDER HEAD 1	1	1	
20	91810-14805	定位销 PIN, DOWEL	2	2	
21	91810-14805	定位销 PIN, DOWEL	2	2	
22	91312-06090	螺栓 BOLT	2	2	
23	1CC-E1310-02	气缸 CYLINDER	1	1	
24	1CC-E1351-00	气缸衬垫 GASKET, CYLINDER	1	1	
25	1CC-E4987-00	软管 HOSE	1	1	
26	90467-13804	卡环 CLIP	2	2	

FIG. 1 气缸头

CYLINDER HEAD

参照 号码	零件号码 PART NO.	零件名称 DESCRIPTION	1CCB	1CCC				备注 REMARKS
27	90116-08811	双头螺栓 BOLT, STUD	4	4				

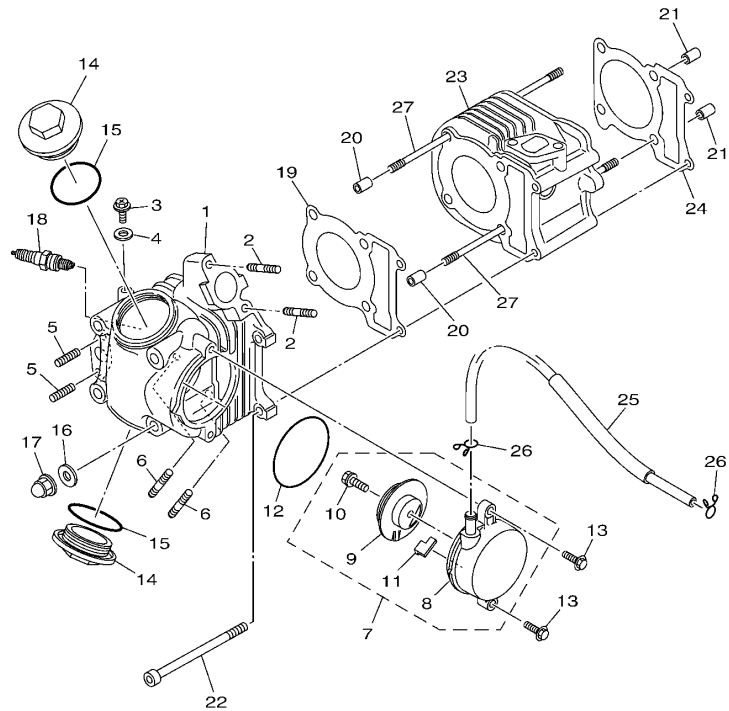

  
1CC7415-M010

FIG. 2 曲柄·活塞

CRANKSHAFT & PISTON

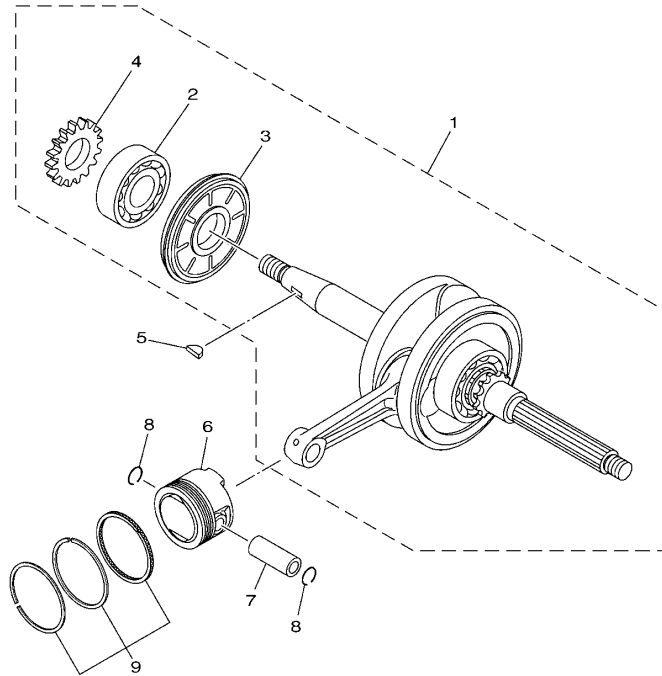

参照 号码	零件号码 PART NO.	零件名称 DESCRIPTION	1CCB	1CCC	备注 REMARKS
1	1CC-E1400-10	曲轴组合 CRANKSHAFT ASSY	1		
	1CC-E1400-00	曲轴组合 CRANKSHAFT ASSY		1	
2	93306-205XY	.轴承 .BEARING	1	1	
3	1CC-E3451-10	.转子过滤器 .FILTER,ROTARY	1		
	1CC-E3451-00	.转子过滤器 .FILTER,ROTARY		1	
4	1CC-E3324-10	.机油泵驱动齿轮 .GEAR, PUMP DRIVE	1		
	1CC-E3324-00	.机油泵驱动齿轮 .GEAR, PUMP DRIVE		1	
5	90280-03045	半圆键 KEY, WOODRUFF	1	1	
6	1CC-E1631-00	活塞 (STD) PISTON (STD)	1	1	
7	1CC-E1633-10	活塞销 PIN, PISTON	1	1	
8	93450-15825	卡环 CIRCLIP	2	2	
9	1CC-E1603-00	活塞环套件 (STD) PISTON RING SET (STD)	1	1	

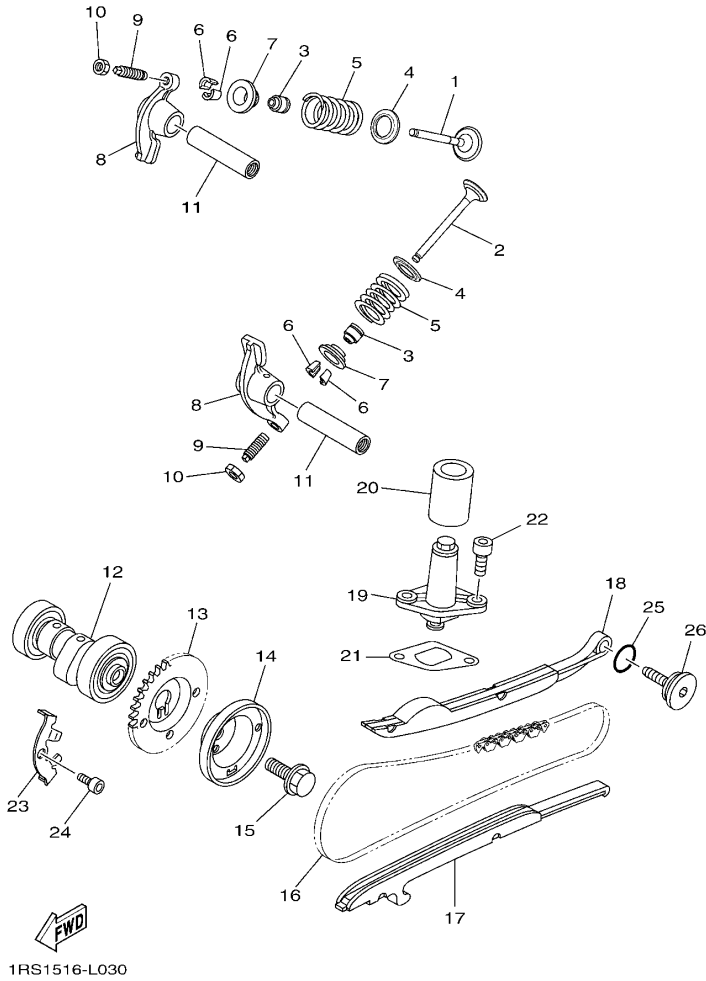

FIG. 3 凸轮轴·链条

CAMSHAFT & CHAIN

参照 号码	零件号码 PART NO.	零件名称 DESCRIPTION	TCB	1CC	备注 REMARKS
1	1CC-E2111-00	进气门 VALVE, INTAKE	1	1	
2	1CC-E2121-00	排气门 VALVE, EXHAUST	1	1	
3	1CC-E2119-00	气门油封 SEAL, VALVE STEM	2	2	
4	1CC-E2116-00	气门弹簧座 SEAT, VALVE SPRING	2	2	
5	1CC-E2113-00	气门内弹簧 SPRING, VALVE INNER	2	2	
6	1CC-E2118-00	气门锁夹 LOCK, VALVE SPRING RETAINER	4	4	
7	1CC-E2117-00	气门弹簧座 RETAINER, VALVE SPRING	2	2	
8	1CC-E2151-00	气门摇臂 ARM, VALVE ROCKER	2	2	
9	1CC-E2159-00	气门调整螺钉 SCREW, VALVE ADJUSTING	2	2	
10	90170-05801	螺母 NUT	2	2	
11	1CC-E2156-00	摇臂轴 2 SHAFT, ROCKER 2	2	2	
12	1CC-E2170-10	凸轮轴组合 1 CAMSHAFT ASSY 1	1		
	1CC-E2170-00	凸轮轴组合 1 CAMSHAFT ASSY 1		1	
13	1CC-E2176-00	链轮 SPROCKET, CAM CHAIN	1	1	
14	1CC-E1145-00	通气管面板 2 PLATE, BREATHER 2	1	1	
15	95812-08016	凸缘螺栓 BOLT, FLANGE	1	1	
16	94568-A2084	链条 CHAIN	1	1	
17	1CC-E2231-00	导向限位板 1 GUIDE, STOPPER 1	1	1	
18	1CC-E2241-00	导向限位板 2 GUIDE, STOPPER 2	1	1	
19	5WY-E2210-10	链条张紧器组合 TENSIONER ASSY, CAM CHAIN	1	1	
20	4KL-E2232-00	减震器 DAMPER	1	1	
21	5MH-E2213-10	张紧器垫片 GASKET, TENSIONER CASE	1	1	
22	91312-06016	螺栓 BOLT	2	2	
23	1CC-E1111F-00	面板 PLATE	1	1	
24	91312-06012	螺栓 BOLT	1	1	
25	93210-15171	O型环 O-RING	1	1	
26	5MH-E2157-01	锁紧螺母 BOLT	1	1	

FIG. 4 空气罩&风扇

AIR SHROUD & FAN

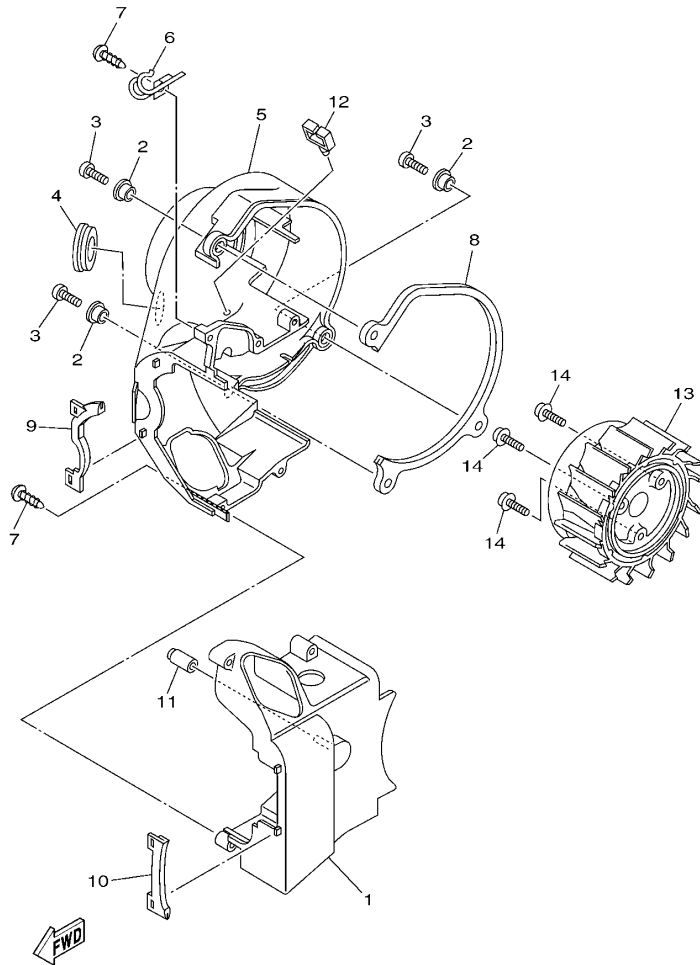

1CC1415-K040

参照 号码	零件号码 PART NO.	零件名称 DESCRIPTION	TCB	TC	CC	备注 REMARKS
1	1CC-E2651-00	气缸空气罩 1 AIR SHROUD, CYLINDER 1	1	1		
2	90387-068K5	轴套 COLLAR	3	3		
3	98502-06020	十字螺钉 SCREW, PAN HEAD	3	3		
4	90480-30800	橡胶垫 GROMMET	1	1		
5	1CC-E2652-00	气缸空气罩 2 AIR SHROUD, CYLINDER 2	1	1		
6	90465-12803	夹箍 CLAMP	1	1		
7	97702-60530	自攻螺钉 SCREW, TAPPING	5	5		
8	1CC-E2658-00	冷却风道避震垫 1 DAMPER, AIR SHROUD 1	1	1		
9	1CC-E2659-00	冷却风道避震垫 2 DAMPER, AIR SHROUD 2	1	1		
10	1CC-E2668-00	冷却风道避震垫 3 DAMPER, AIR SHROUD 3	1	1		
11	1CC-E3569-00	绝缘插头 PLUG, BLIND	1	1		
12	90464-08020	线夹 CLAMP	1	1		
13	1CC-E2611-00	风扇 FAN	1	1		
14	97602-06214	带垫圈大柱头螺钉 SCREW, PAN HEAD WITH WASHER	3	3		

FIG. 5 油泵

OIL PUMP

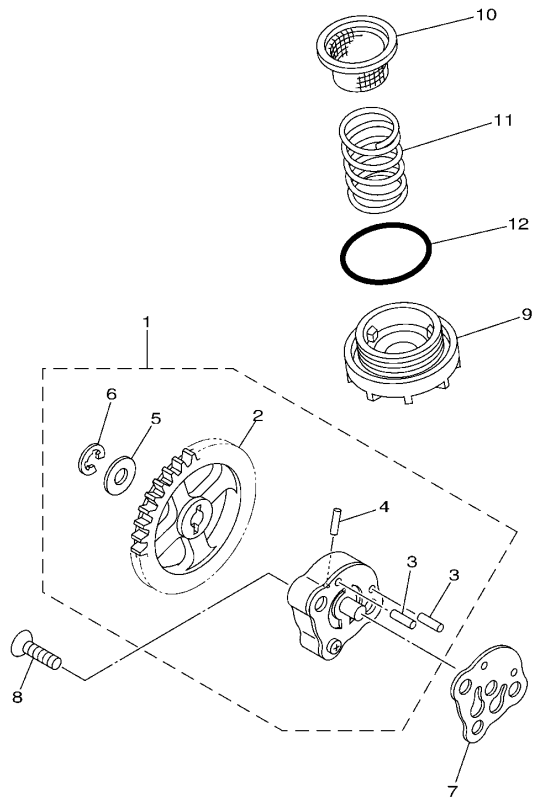

参照 号码	零件号码 PART NO.	零件名称 DESCRIPTION	TCB	CCC			备注 REMARKS
1	1CC-E3300-10	机油泵总成 OIL PUMP ASSY	1	1			
2	1CC-E3325-10	.从动齿轮 .GEAR, PUMP DRIVEN	1	1			
3	1CC-E3362-00	.定位销 1 .ROLLER	2	2			
4	1CC-E3363-00	.定位销 2 .ROLLER	1	1			
5	90201-07811	.平垫圈 .WASHER, PLATE	1	1			
6	99001-05600	.卡环 .CIRCLIP	1	1			
7	5WY-E3475-10	衬垫 GASKET	1	1			
8	98702-06020	平头螺钉 SCREW, FLAT HEAD	2	2			
9	4KL-E5351-10	放油塞 PLUG, DRAIN	1	1			
10	4KL-E3411-01	机油滤网 STRAINER, OIL	1	1			
11	90501-16829	压簧 SPRING, COMPRESSION	1	1			
12	93210-34803	O型环 O-RING	1	1			

  
1CC1415-K050



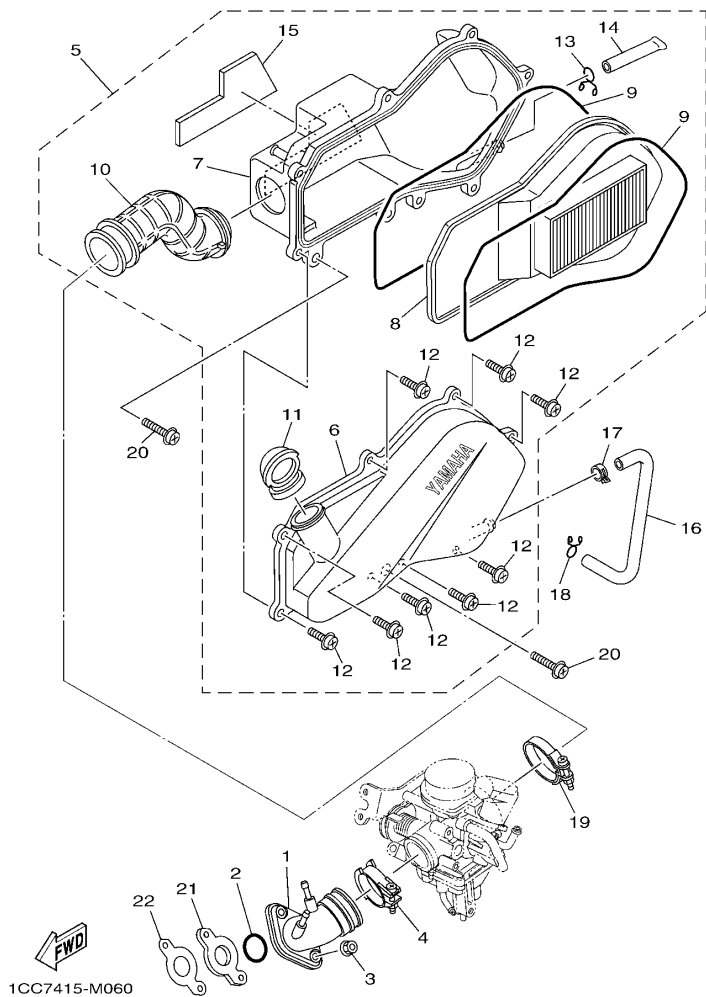
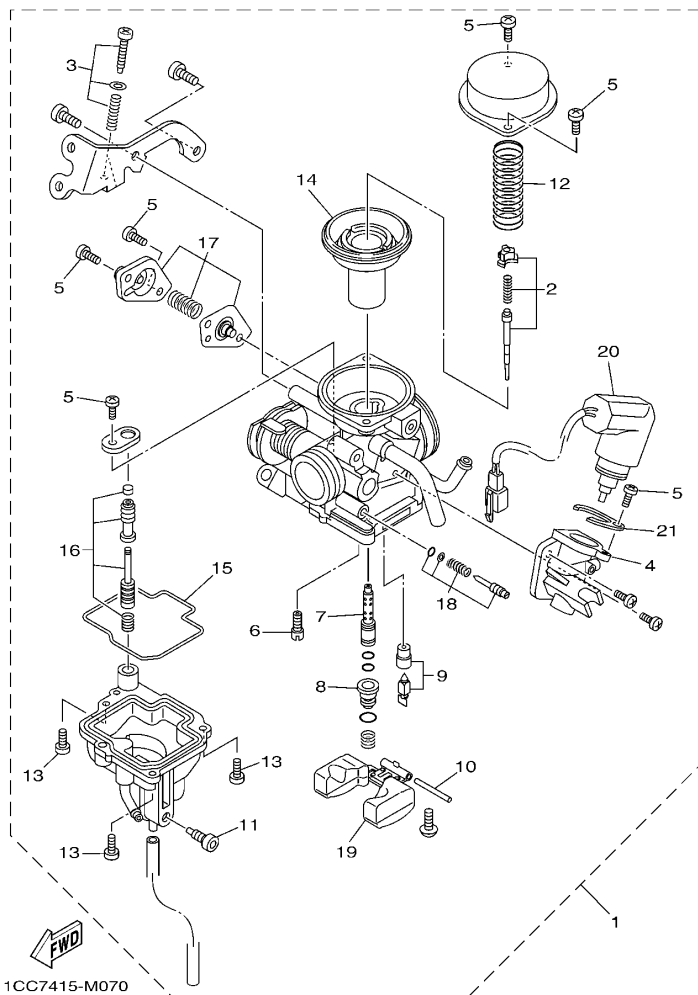

FIG. 6 进气门

INTAKE

参照 号码	零件号码 PART NO.	零件名称 DESCRIPTION	TCCB	TCC		备注 REMARKS
1	1CC-E3585-00	岐管 MANIFOLD	1	1		
2	93210-25806	O型环 O-RING	1	1		
3	95702-06500	螺母 NUT, FLANGE	2	2		
4	1CC-E3575-00	箍带 BAND	1	1		
5	4S0-E4410-03	空气净化器组合 AIR CLEANER ASSY.	1	1		
6	4S0-E4412-01	.空气净化器箱盖 1 .CAP, CLEANER CASE 1	1	1		
7	4S0-E4411-02	.空气净化器箱 1 .CASE, AIR CLEANER 1	1	1		
8	4S0-E4451-01	.空气滤芯 .ELEMENT, AIR CLEANER	1	1		
9	5WG-E4476-00	.密封圈 .SEAL	2	2		
10	4S0-E4453-00	.空气净化器接头 1 .JOINT, AIR CLEANER 1	1	1		
11	4S0-E4437-00	.导管 .DUCT	1	1		
12	97602-06220	.带垫圈大柱头螺钉 .SCREW, PAN HEAD W/WASHER	8	8		
13	90467-12802	.卡环 .CLIP	1	1		
14	5WY-E443E-01	.排水管 .PIPE, DRAIN	1	1		
15	4S0-E4409-00	.减震器 .DAMPER	1	1		
16	4S0-E443G-00	排气管 PIPE, DRAIN 2	1	1		
17	90467-13815	卡环 CLIP	1	1		
18	90467-12802	卡环 CLIP	1	1		
19	90450-45801	软管夹组合 HOSE CLAMP ASSY	1	1		
20	97602-06225	带垫圈大柱头螺钉 SCREW, PAN HEAD WITH WASHER	2	2		
21	1CC-E3595-00	接头 JOINT	1	1		
22	1CC-E3556-00	岐管衬垫 GASKET, MANIFOLD	1	1		



1CC7415-M070

FIG. 7 化油器

CARBURETOR

参照 号码	零件号码 PART NO.	零件名称 DESCRIPTION	TCCB	TCCC	备注 REMARKS
1	1CC-E4301-00	化油器总成 1 CARBURETOR ASSY 1	1	1	
2	5WB-E490J-30	.滚针套件 .NEEDLE SET	1	1	
3	5WB-E490K-10	.止动螺钉套件 .STOP SCREW SET	1	1	
4	5WB-E4283-10	.化油器盖 1 .COVER, CARBURETOR 1	1	1	
5	98501-04008	.十字螺钉 .SCREW, PAN HEAD	6	6	
6	5WB-E4342-16	.低速量孔 (# 32) .JET, PILOT (# 32)	1	1	
7	5WB-E4341-20	.主喷管 .NOZZLE, MAIN	1	1	
8	5WB-E4343-52	.主量孔 (#104) .JET, MAIN (#104)	1	1	
9	5WB-E4390-00	.针阀组合 .NEEDLE VALVE ASSY	1	1	
10	5LB-E4386-00	.浮子销 .PIN, FLOAT	1	1	
11	5WB-E4115-00	.螺旋 .PLUG, SCREW	1	1	
12	5WB-E4286-10	.弹簧 .SPRING	1	1	
13	97601-04014	.带垫十字螺钉 .SCREW, PAN HEAD WITH WASHER	3	3	
14	5WB-E4340-00	.阀组合 .VALVE ASSY	1	1	
15	5WB-E4384-10	.浮子室衬垫 .GASKET, FLOAT CHAMBER	1	1	
16	5WB-E4504-00	.杆套 .ROD SET	1	1	
17	5WB-E490A-10	.隔膜套件 1 .DIAPHRAGM SET 1	1	1	
18	5WB-E4105-10	.混合气调整螺钉组件 .PILOT SCREW SET	1	1	
19	5WB-E4385-10	.浮子 .FLOAT	1	1	
20	5WB-E4370-10	.柱塞起动器组合 .PLUNGER STARTER ASSY	1	1	
21	5WB-E4346-00	.面板 .PLATE	1	1	

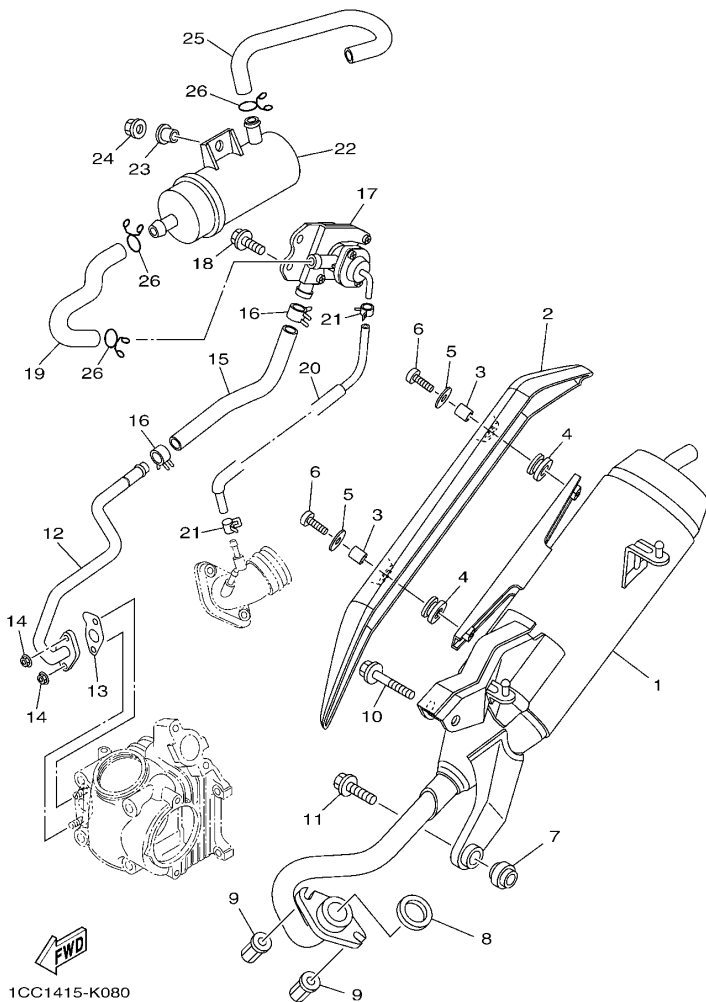
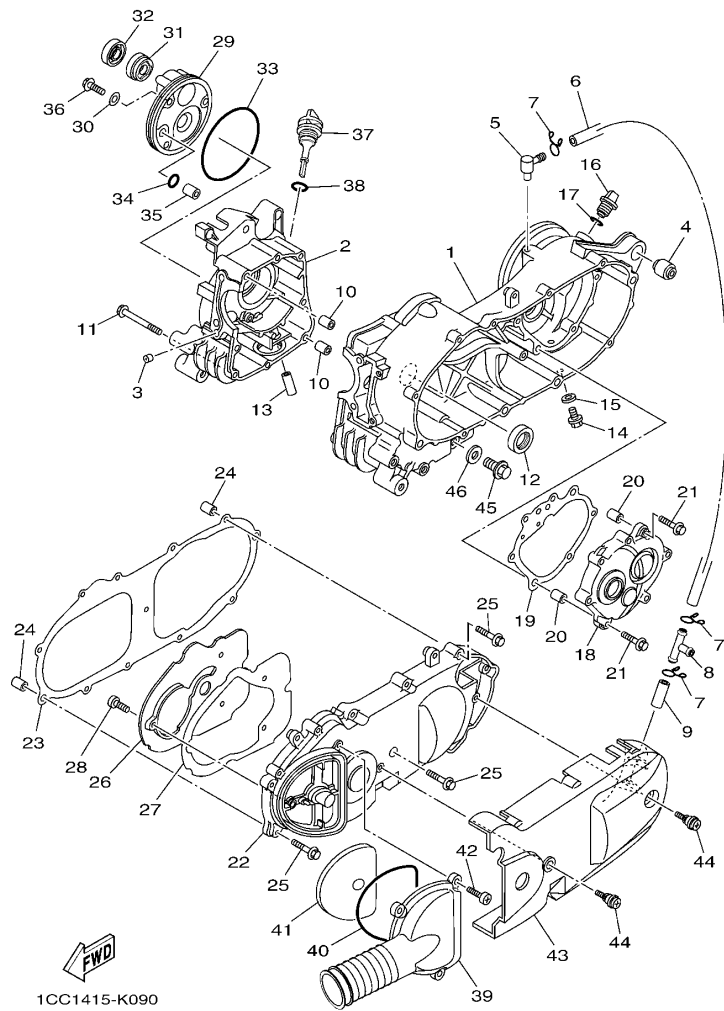

FIG. 8 排气装置

EXHAUST

参照 号码	零件号码 PART NO.	零件名称 DESCRIPTION	TCB	CCC	备注 REMARKS
1	5WY-E4610-90	排气管组合 1 EXHAUST PIPE ASSY 1	1	1	
2	1CC-E4718-00	消音器保护器 1 PROTECTOR, MUFFLER 1	1	1	
3	90387-068F6	轴套 COLLAR	2	2	
4	1CC-E4445-00	固定套 GROMMET	2	2	
5	90201-06814	平垫圈 WASHER, PLATE	2	2	
6	98980-06020	螺钉 SCREW, BIND	2	2	
7	4KL-E4737-00	消音器减震器 DAMPER, MUFFLER	1	1	
8	4KL-E4613-10	排气管衬垫 GASKET, EXHAUST PIPE	1	1	
9	90179-06850	螺母 NUT	2	2	
10	95812-08050	凸缘螺栓 BOLT, FLANGE	1	1	
11	95812-08030	凸缘螺栓 BOLT, FLANGE	1	1	
12	5WY-E4872-30	管 2 PIPE 2	1	1	
13	5WG-E4815-00	衬垫 GASKET	1	1	
14	95702-06500	螺母 NUT, FLANGE	2	2	
15	4S0-E4883-00	弯曲软管 3 HOSE, BEND 3	1	1	
16	90467-16805	卡环 CLIP	2	2	
17	5WB-E4803-11	二次进气系统 AIR INDUCTION SYSTEM ASSY	1	1	
18	95802-06012	凸缘螺栓 BOLT, FLANGE	2	2	
19	4S0-E4884-00	弯曲软管 4 HOSE, BEND 4	1	1	
20	4S0-E3542-10	负压传感软管 1 HOSE, VACUUM SENSING 1	1	1	
21	90467-08070	卡环 CLIP	2	2	
22	5WG-E4806-01	空气滤芯器 AIR FILTER	1	1	
23	90387-068J2	轴套 COLLAR	1	1	
24	95702-06500	螺母 NUT, FLANGE	1	1	
25	4S5-E4885-00	弯曲软管 5 HOSE, BEND 5	1	1	
26	90467-16808	卡环 CLIP	3	3	



1CC1415-K090

FIG. 9 曲轴箱

CRANKCASE

参照 号码	零件号码 PART NO.	零件名称 DESCRIPTION	1CCB	1CCC			备注 REMARKS
1	1CC-E5111-00	曲轴箱 1 CRANKCASE 1	1	1			
2	1CC-E5121-00	曲轴箱 2 CRANKCASE 2	1	1			
3	1CC-E5138-00	喷管 1 NOZZLE 1	1	1			
4	4KL-F2216-00	后减震器衬套 BUSH, REAR SHOCK ABSORBER	1	1			
5	5MH-E5371-00	通气管接头 BREATHER	1	1			
6	1CC-E5373-00	通气管 PIPE, BREATHER	1	1			
7	90467-12802	卡环 CLIP	3	3			
8	90413-12800	轨道 3 WAY 3	1	1			
9	4S0-E5393-00	通气管 2 PIPE, BREATHER 2	1	1			
10	91810-14805	定位销 PIN, DOWEL	2	2			
11	95022-06070	凸缘螺栓 BOLT, FLANGE	8	8			
12	93102-22811	油封 OIL SEAL	1	1			
13	1CC-E3416-00	机油管 1 PIPE, OIL 1	1	1			
14	95812-08016	凸缘螺栓 BOLT, FLANGE	1	1			
15	90430-08119	衬垫 GASKET	1	1			
16	4KL-E5363-00	机油塞 PLUG, OIL	1	1			
17	93210-14815	O型环 O-RING	1	1			
18	1CC-E5421-00	曲轴箱盖 2 COVER, CRANKCASE 2	1	1			
19	1CC-E5461-00	曲轴箱盖衬垫 2 GASKET, CRANKCASE COVER 2	1	1			
20	91810-14805	定位销 PIN, DOWEL	2	2			
21	95022-06030	凸缘螺栓 BOLT, FLANGE	7	7			
22	1CC-E5411-00	曲轴箱盖 1 COVER, CRANKCASE 1	1	1			
23	1CC-E5451-00	曲轴箱盖衬垫 1 GASKET, CRANKCASE COVER 1	1	1			
24	91810-14805	定位销 PIN, DOWEL	2	2			
25	95022-06035	凸缘螺栓 BOLT, FLANGE	12	12			
26	1CC-E5191-00	面板 PLATE	1	1			
27	1CC-E5455-00	衬垫 1 GASKET 1	1	1			

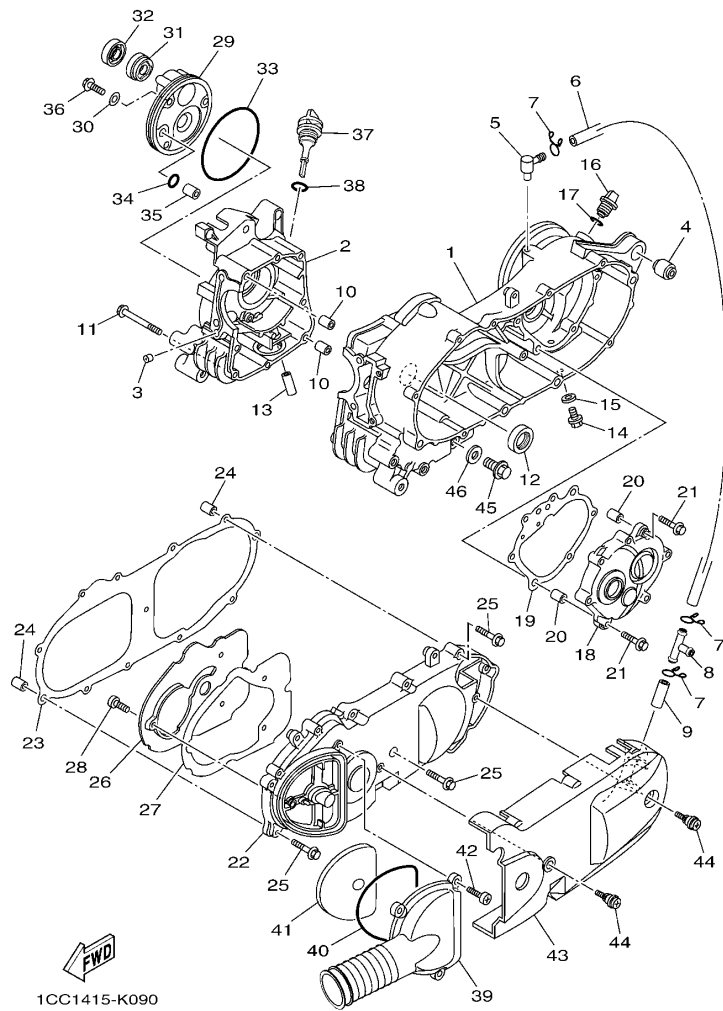
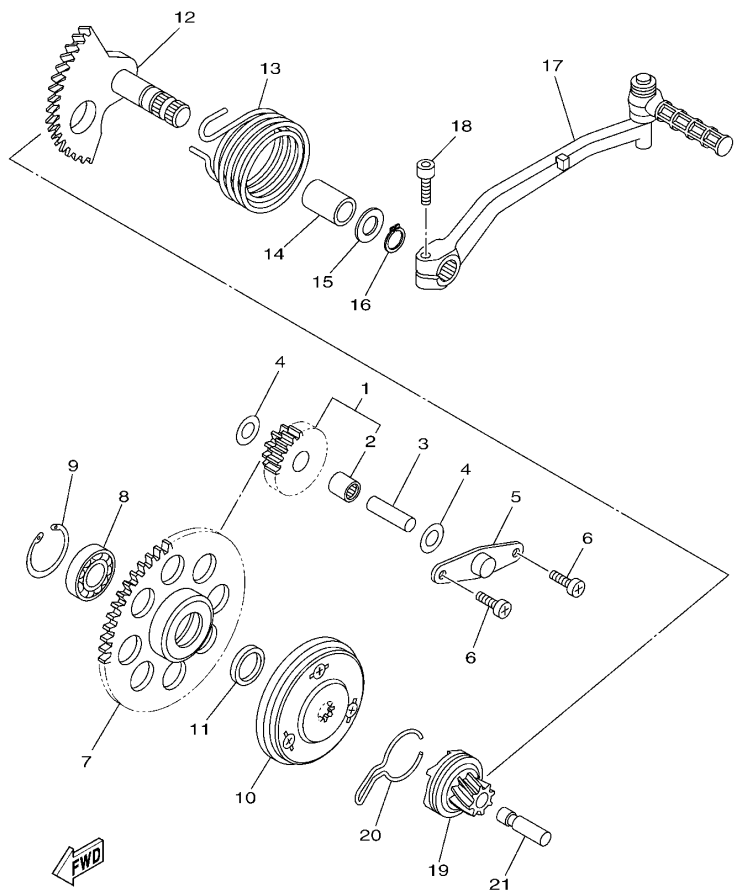

FIG. 9 曲轴箱

CRANKCASE

参照 号码	零件号码 PART NO.	零件名称 DESCRIPTION	1CCB	1CCC	备注 REMARKS
28	98902-06010	十字槽盘头螺钉 SCREW, BIND	3	3	
29	1CC-E5417-00	盖 1 COVER, CAP	1	1	
30	90430-06014	衬垫 GASKET	3	3	
31	93102-19805	油封 OIL SEAL	1	1	
32	93102-19810	油封 OIL SEAL	1	1	
33	93211-02802	O 型环 O-RING	1	1	
34	93210-07809	O 型环 O-RING	1	1	
35	91808-12804	定位销 PIN, DOWEL	1	1	
36	95022-06020	凸缘螺栓 BOLT, FLANGE	3	3	
37	1CC-E5363-10	机油塞 PLUG, OIL	1	1	
38	93210-26812	O 型环 O-RING	1	1	
39	1CC-E5471-00	空气导管 DUCT, AIR	1	1	
40	1CC-E5472-00	空气导管密封圈 SEAL, AIR DUCT	1	1	
41	1CC-E5407-00	滤芯 1 ELEMENT 1	1	1	
42	98902-06020	十字槽盘头螺钉 SCREW, BIND	3	3	
43	1CC-X1543-01	曲轴箱盖 3 COVER, CRANKCASE 3	1	1	
44	1CC-E5481-00	螺栓 1 BOLT 1	2	2	
45	90340-12806	螺塞 PLUG, STRAIGHT SCREW	1	1	
46	90201-12172	平垫圈 WASHER, PLATE	1	1	



1CC1415-K100

FIG. 10 起动机

STARTER

参照 号码	零件号码 PART NO.	零件名称 DESCRIPTION	1CCB	1CCC				备注 REMARKS
1	1CC-E5650-00	中间齿轮组合 IDLE GEAR ASSY	1	1				
2	93317-110Y4	. 轴承 . BEARING	1	1				
3	5WG-E5521-00	轴 1 SHAFT 1	1	1				
4	90201-108A3	平垫圈 WASHER, PLATE	2	2				
5	5MH-E5532-00	惰齿轮面板 PLATE, IDLE GEAR	1	1				
6	98502-06012	十字螺钉 SCREW, PAN HEAD	2	2				
7	1CC-E5524-00	起动机齿轮 WHEEL, STARTER	1	1				
8	93306-003YK	轴承 BEARING	1	1				
9	99009-35700	卡环 CIRCLIP	1	1				
10	1CC-E5570-00	起动离合器组合 STARTER CLUTCH ASSY	1	1				
11	90387-16806	轴套 COLLAR	1	1				
12	1CC-E5601-10	起动机轴组合 KICK SHAFT ASSY	1	1				
13	90508-32804	扭簧 SPRING, TORSION	1	1				
14	90380-15806	固体套管 BUSH, SOLID	1	1				
15	90201-15838	平垫圈 WASHER, PLATE	1	1				
16	99009-15400	卡环 CIRCLIP	1	1				
17	1CC-E5620-00	起动机曲柄组合 KICK CRANK ASSY	1	1				
18	91312-06025	螺栓 BOLT	1	1				
19	1CC-E5630-10	起动机小齿轮组合 KICK PINION ASSY	1	1				
20	1CC-E5673-00	钢夹 CLIP	1	1				
21	1CC-E5659-00	轴 SHAFT	1	1				

FIG. 11 离合器

CLUTCH

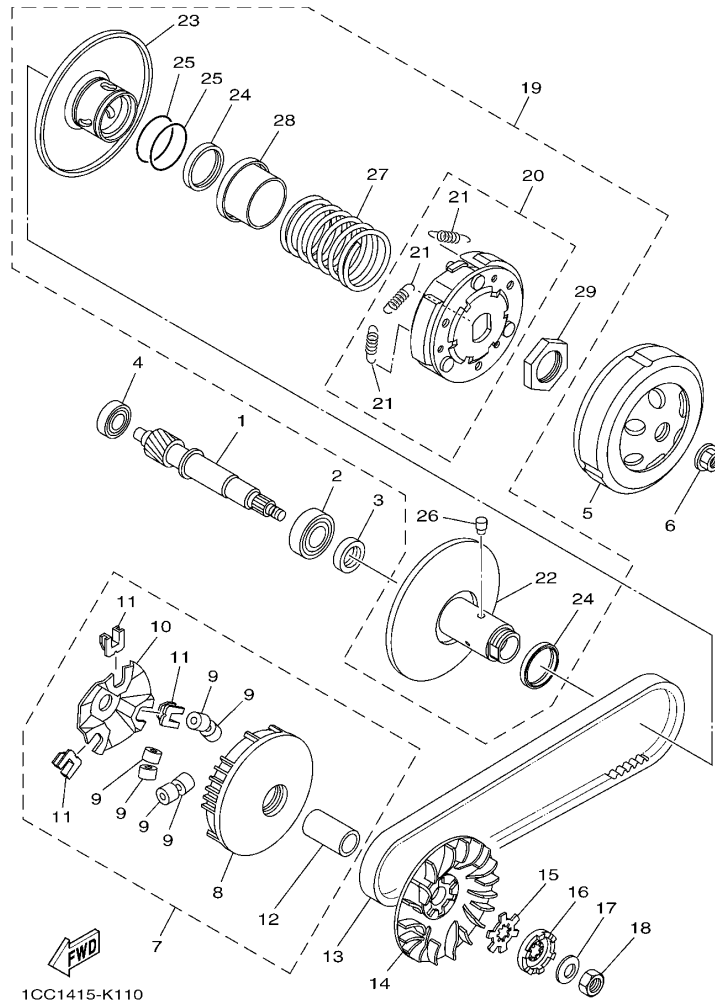

1CC1415-K110

参照 号码	零件号码 PART NO.	零件名称 DESCRIPTION	TCB	1CC		备注 REMARKS
1	1CC-E6111-10	初级驱动齿轮 GEAR, PRIMARY DRIVE	1	1		
2	93306-253Y0	轴承 BEARING	1	1		
3	93102-17808	油封 OIL SEAL	1	1		
4	93306-200X0	轴承 BEARING	1	1		
5	1CC-E6611-01	离合器壳体组合 CLUTCH HOUSING COMP.	1	1		
6	90179-10817	螺母 NUT	1	1		
7	1CC-E7601-00	主槽轮组合 PRIMARY SHEAVE ASSY	1	1		
8	1CC-E7620-00	.主滑轮组合 .PRIMARY SLIDING SHEAVE COMP.	1	1		
9	1CC-E7632-00	.重锤 .WEIGHT	6	6		
10	1CC-E7623-00	.凸轮 .CAM	1	1		
11	1CC-E7653-00	.滑块 .SLIDER	3	3		
12	90387-16816	.轴套 .COLLAR	1	1		
13	1CC-E7641-10	V型皮带 V-BELT	1			
	1CC-E7641-00	V型皮带 V-BELT		1		
14	1CC-E7611-00	主固定槽 SHEAVE, PRIMARY FIXED	1	1		
15	90214-14804	爪形垫圈 WASHER, CLAW	1	1		
16	1CC-E5657-00	单向离合器 CLUTCH, ONEWAY	1	1		
17	90208-12050	弹性挡圈 WASHER, CONICAL SPRING	1	1		
18	95302-12700	螺母 NUT	1	1		
19	1CC-E7602-10	副槽轮组合 SECONDARY SHEAVE ASSY	1	1		
20	1CC-E6620-10	.离合器载架组合 .CLUTCH CARRIER ASSY	1	1		
21	1CC-E6626-10	.离合器重锤弹簧 1 .SPRING, CLUTCH WEIGHT 1	3	3		
22	1CC-E7660-00	.副固定槽轮组合 .SECONDARY FIXED SHEAVE COMP.	1	1		
23	1CC-E7670-00	.副滑轮 .SECONDARY SLIDING SHEAVE	1	1		
24	93109-33803	.油封 .OIL SEAL	2	2		
25	93210-36800	.O型环 .O-RING	2	2		
26	1CC-E7664-00	.导承销 .PIN, GUIDE	2	2		

FIG. 11 离合器

CLUTCH

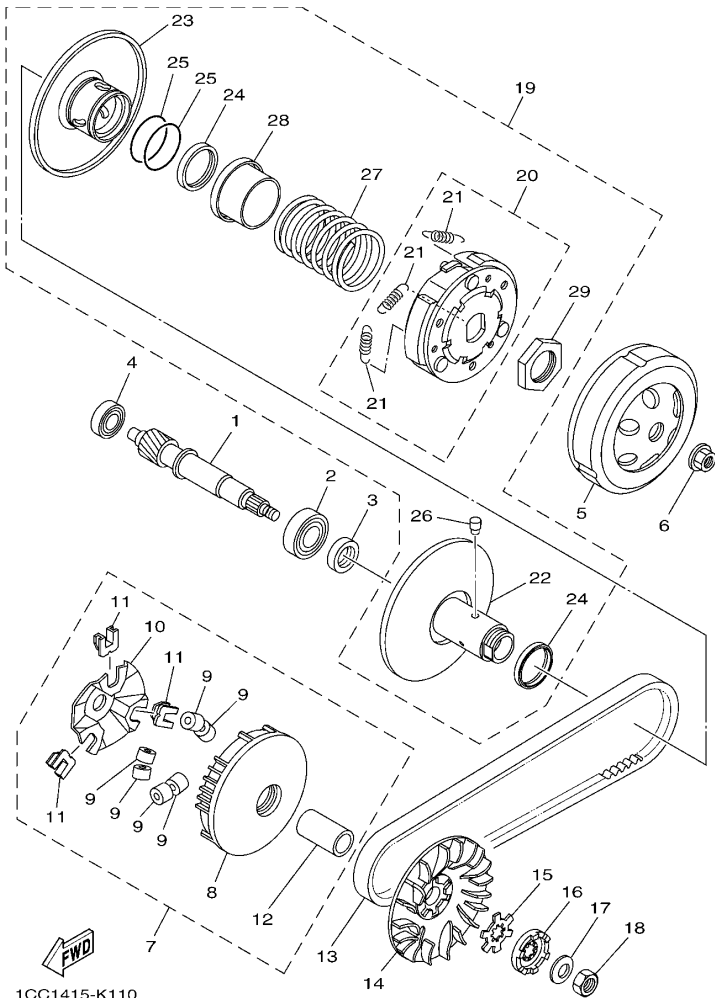

参照 号码	零件号码 PART NO.	零件名称 DESCRIPTION	TCCB	TCCC			备注 REMARKS
27	90501-43804	. 压簧 .SPRING, COMPRESSION	1	1			
28	1CC-E7684-00	. 辅助弹簧座 .SEAT, SECONDARY SPRING	1	1			
29	90170-28802	. 螺母 .NUT	1	1			



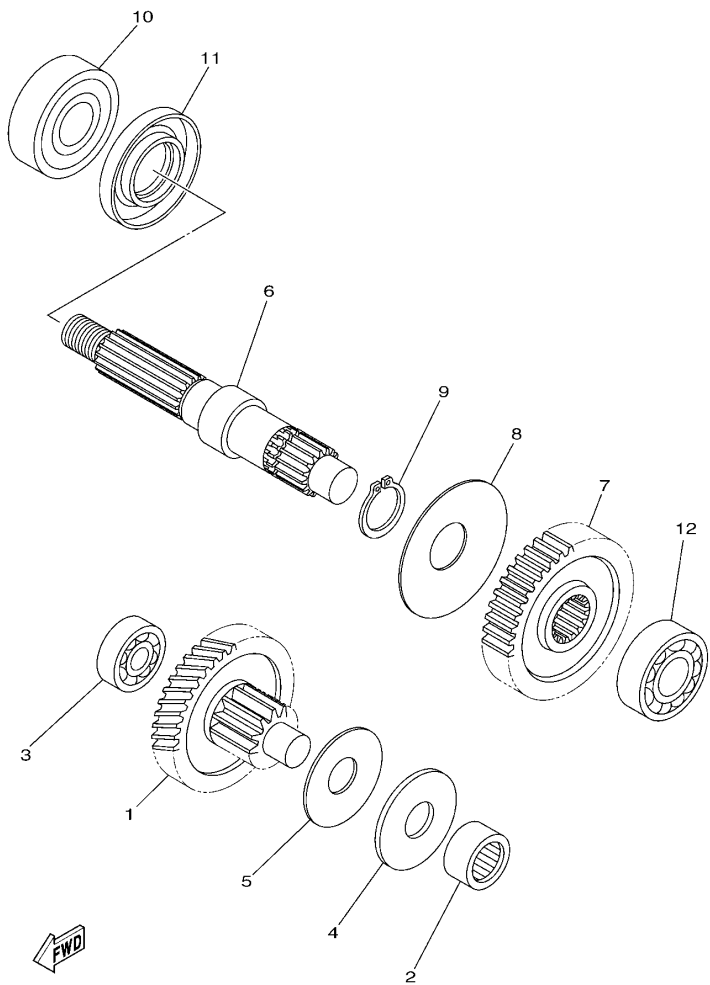

5WYG415-L120

FIG. 12 传动

TRANSMISSION

参照 号码	零件号码 PART NO.	零件名称 DESCRIPTION	TCB	ICC			备注 REMARKS
1	1CC-E7410-10	主轮轴组 MAIN AXLE COMP. (13T/47T)	1	1			
2	93311-315X0	轴承 BEARING	1	1			
3	93306-200X0	轴承 BEARING	1	1			
4	90201-15803	平垫圈 WASHER, PLATE	1	1			
5	90208-15801	弹性挡圈 WASHER, CONICAL SPRING	1	1			
6	1CC-E7421-10	驱动轴 AXLE, DRIVE	1	1			
7	1CC-E7211-10	一档从动齿轮 GEAR, 1ST WHEEL (39T)	1	1			
8	90208-21802	弹性挡圈 WASHER, CONICAL SPRING	1	1			
9	93410-20823	卡环 CIRCLIP	1	1			
10	93306-204XC	轴承 BEARING	1	1			
11	93102-26852	油封 OIL SEAL	1	1			
12	93306-253Y0	轴承 BEARING	1	1			

FIG. 13 车架

FRAME

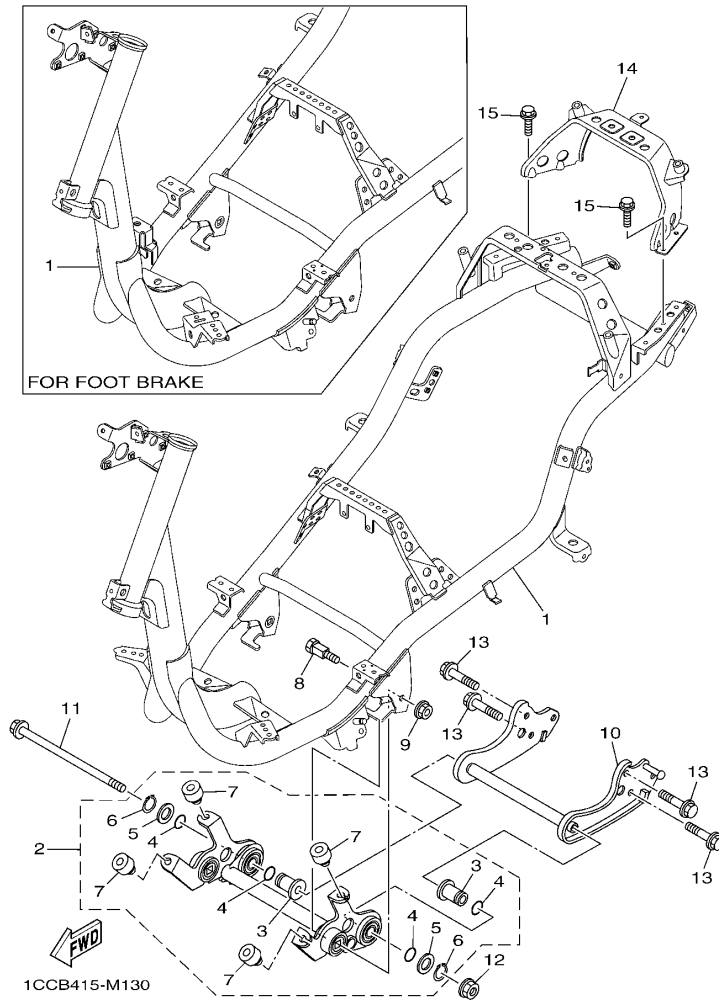

参照 号码	零件号码 PART NO.	零件名称 DESCRIPTION	TCCB	TCCC	备注 REMARKS
1	1CC-F1110-01	车架组合 FRAME COMP.	1		
	1CC-F1110-11	车架组合 FRAME COMP.		1	
2	1CC-X2142-00	发动机托架组合 2 ENGINE BRACKET COMP.2	1	1	
3	5WG-E5317-01	.发动机架衬套 .SPACER, ENGINE MOUNT	2	2	
4	93210-15639	.O型环 .O-RING	4	4	
5	90201-17804	.平垫圈 .WASHER, PLATE	2	2	
6	99009-17400	.卡环 .CIRCLIP	2	2	
7	5WG-F118W-00	.限位板 .STOPPER	4	4	
8	5WG-F1481-01	发动机装配螺栓 1 BOLT, ENGINE MOUNTING 1	2	2	
9	95602-10200	自锁螺母 NUT, U FLANGE	2	2	
10	1CC-F1410-00	发动机托架组合 ENGINE BRACKET COMP.	1	1	
11	5WG-F1482-01	发动机装配螺栓 2 BOLT, ENGINE MOUNTING 2	1	1	
12	95602-10200	自锁螺母 NUT, U FLANGE	1	1	
13	95812-10030	凸缘螺栓 BOLT, FLANGE	4	4	
14	1CC-F116F-00	后支承 STAY, REAR	1	1	
15	95802-06014	凸缘螺栓 BOLT, FLANGE	4	4	

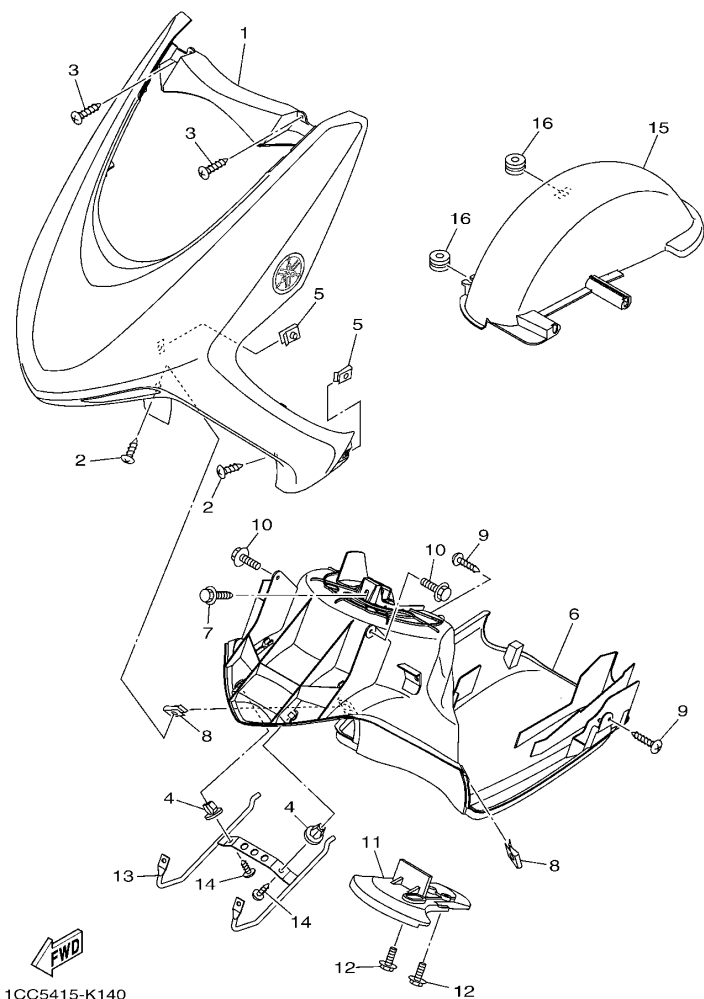

FIG. 14 挡泥板

FENDER

参照 号码	零件号码 PART NO.	零件名称 DESCRIPTION	TCB	CCC	备注 REMARKS
1	1CC-X2150-00-P2	前挡泥板 FRONT FENDER ASSY	1	1	UR 金属黑色车用 UR FOR SMX
	1CC-X2150-00-P4	前挡泥板 FRONT FENDER ASSY	1	1	UR 浓红车用 UR FOR DRMK
	1CC-X2150-00-UG	前挡泥板 FRONT FENDER ASSY	1	1	UR 棕色车用 UR FOR IPB
	1CC-X2150-00-P5	前挡泥板 FRONT FENDER ASSY	1	1	UR 发紫浅蓝 3 车用 UR FOR PPBM3
	1CC-X2150-00-P3	前挡泥板 FRONT FENDER ASSY	1	1	UR 金属白车用 UR FOR WM1
2	97702-50012	自攻螺钉 SCREW, TAPPING	2	2	
3	97702-50016	自攻螺钉 SCREW, TAPPING	2	2	
4	90269-09800	铆钉 RIVET	2	2	
5	90183-05818	弹性螺母 NUT, SPRING	2	2	
6	1CC-F1552-01	内防护板 FENDER, INNER	1	1	
7	90119-068A3	带垫螺栓 BOLT, WITH WASHER	1	1	
8	90183-05818	弹性螺母 NUT, SPRING	2	2	
9	97702-50016	自攻螺钉 SCREW, TAPPING	2	2	
10	90119-05827	带垫螺栓 BOLT, WITH WASHER	2	2	
11	5WG-F1553-00	内防护板 2 FENDER, INNER 2	1	1	
12	90119-06157	带垫螺栓 BOLT, WITH WASHER	2	2	
13	1CC-F1587-00	支架 1 STAY 1	1	1	
14	97702-60016	自攻螺钉 SCREW, TAPPING	2	2	
15	1CC-F1611-00	后挡泥板 FENDER, REAR	1	1	
16	90480-12803	橡胶垫 GROMMET	2	2	

FIG. 15 侧盖

SIDE COVER

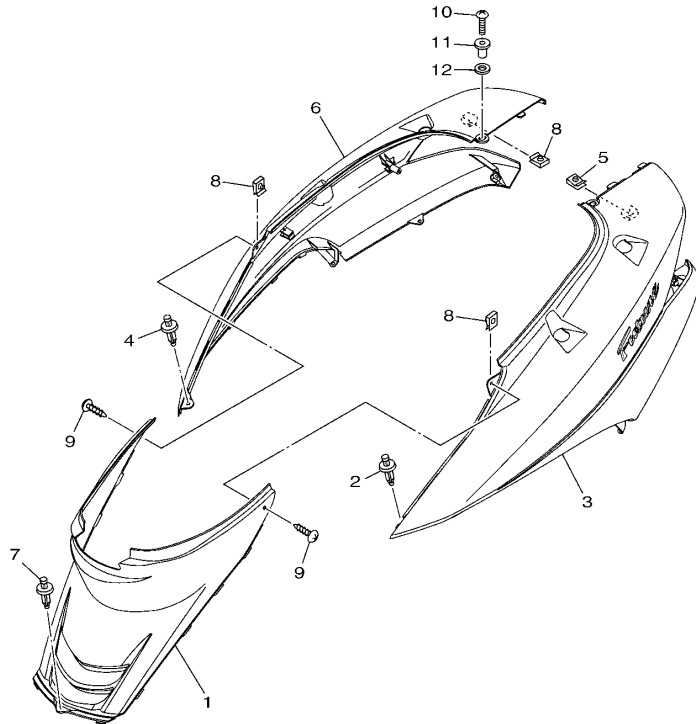

  
1CC7415-M150

参照 号码	零件号码 PART NO.	零件名称 DESCRIPTION	1CCB	1CCC			备注 REMARKS
1	1CC-F1711-00	侧盖 1 COVER, SIDE 1	1	1			
2	90269-06809	铆钉 RIVET	1	1			
3	1CC-X2172-30-P2	侧盖 2 COVER, SIDE 2	1	1			UR 金属黑色车用 UR FOR SMX
	1CC-X2172-30-P4	侧盖 2 COVER, SIDE 2	1	1			UR 浓红车用 UR FOR DRMK
	1CC-X2172-30-UG	侧盖 2 COVER, SIDE 2	1	1			UR 棕色车用 UR FOR IPB
	1CC-X2172-30-P5	侧盖 2 COVER, SIDE 2	1	1			UR 发紫浅蓝 3 车用 UR FOR PPBM3
	1CC-X2172-30-P3	侧盖 2 COVER, SIDE 2	1	1			UR 金属白车用 UR FOR WM1
4	90269-06809	铆钉 RIVET	1	1			
5	90183-05818	弹性螺母 NUT, SPRING	1	1			
6	1CC-X2173-30-P2	侧盖 3 COVER, SIDE 3	1	1			UR 金属黑色车用 UR FOR SMX
	1CC-X2173-30-P4	侧盖 3 COVER, SIDE 3	1	1			UR 浓红车用 UR FOR DRMK
	1CC-X2173-30-UG	侧盖 3 COVER, SIDE 3	1	1			UR 棕色车用 UR FOR IPB
	1CC-X2173-30-P5	侧盖 3 COVER, SIDE 3	1	1			UR 发紫浅蓝 3 车用 UR FOR PPBM3
	1CC-X2173-30-P3	侧盖 3 COVER, SIDE 3	1	1			UR 金属白车用 UR FOR WM1
7	90269-06809	铆钉 RIVET	1	1			
8	90183-05818	弹性螺母 NUT, SPRING	3	3			
9	97702-50012	自攻螺钉 SCREW, TAPPING	2	2			
10	98902-06020	十字槽盘头螺钉 SCREW, BIND	1	1			
11	90387-068H6	轴套 COLLAR	1	1			
12	4S5-F1773-00	固定套 GROMMET	1	1			

FIG. 16 后悬挂

REAR SUSPENSION

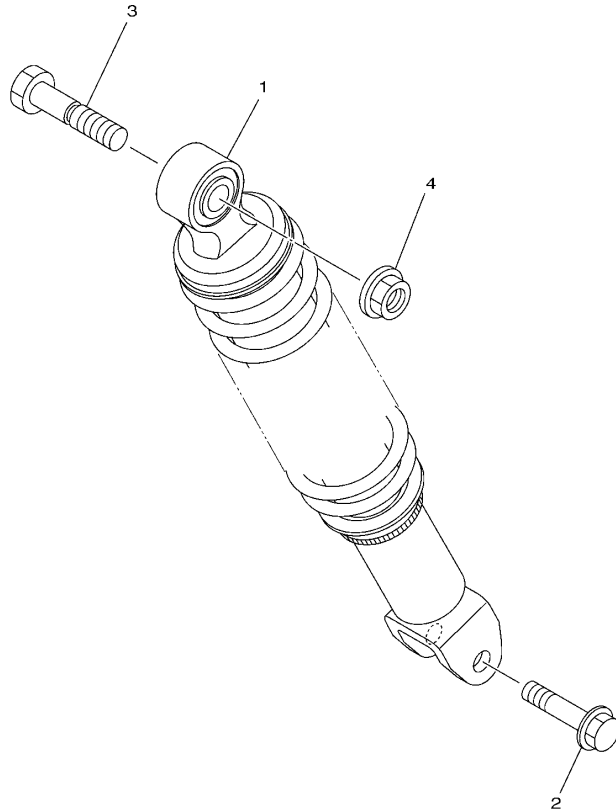

参照 号码	零件号码 PART NO.	零件名称 DESCRIPTION	TCCB	TCCC				备注 REMARKS
1	4S5-F2210-00	后减震器组合 SHOCK ABSORBER ASSY, REAR	1	1				
2	90105-08861	凸缘螺栓 BOLT, FLANGE	1	1				
3	90101-10809	螺栓 BOLT	1	1				
4	95702-10500	螺母 NUT, FLANGE	1	1				

  
1CC1415-K160

FIG. 17 前叉

FRONT FORK

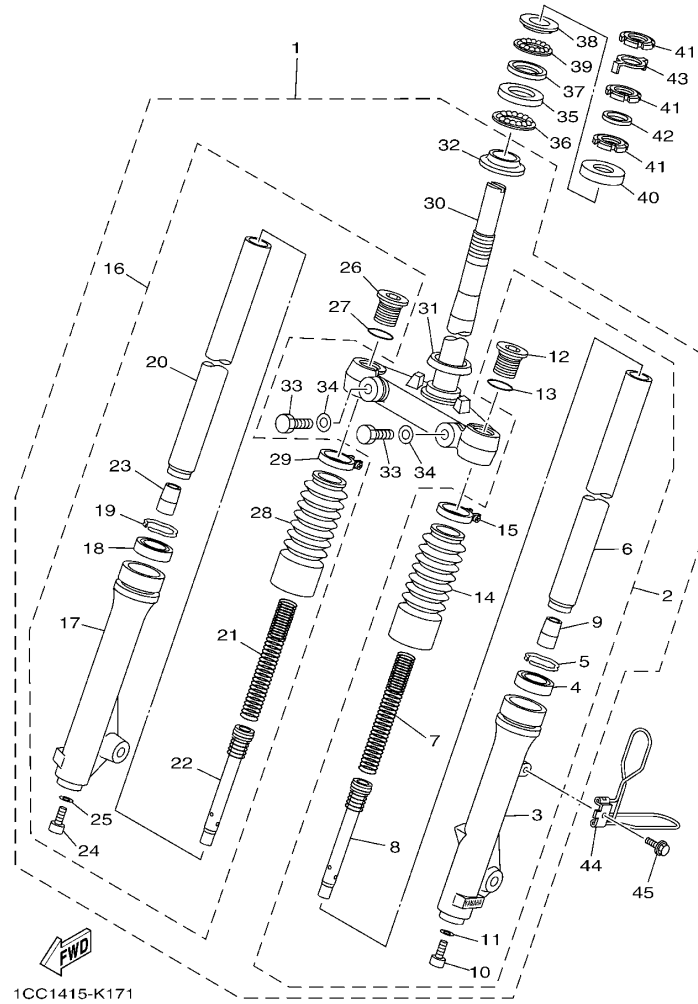

1CC1415-K171

参照 号码	零件号码 PART NO.	零件名称 DESCRIPTION	1CCB	1CCC	备注 REMARKS
1	1CC-F3100-00	前叉组合 FRONT FORK ASSY	1	1	
2	1CC-F3102-00	.前叉组合(左边) .FRONT FORK ASSY (L.H)	1	1	
3	1CC-F3126-00	.外管 1 .TUBE, OUTER (LEFT)	1	1	
4	4GU-F3145-00	.油封 .OIL SEAL	1	1	
5	5AP-F3153-00	.扣环 .RING, SNAP	1	1	
6	5WG-F3110-00	.内管组件 1 .INNER TUBE COMP.1	1	1	
7	5WG-F3141-00	.前叉弹簧 .SPRING, FRONT FORK	1	1	
8	5WG-F3170-00	.柄管缸套 .CYL.COMP.	1	1	
9	4GU-F3173-01	.锥形主轴 .SPINDLE, TAPER	1	1	
10	5LK-F3356-00	.螺栓 2 .BOLT 2	1	1	
11	4TU-F3479-00	.衬垫 .GASKET	1	1	
12	4KL-F3111-00	.顶盖螺栓 .BOLT, CAP	1	1	
13	5AP-F3147-00	.O型环 .O-RING	1	1	
14	4KL-F3191-10	.保护罩 .BOOT	1	1	
15	4KL-F3192-10	.带箍 .BAND	1	1	
16	1CC-F3103-00	.前叉组合(右边) .FRONT FORK ASSY (R.H)	1	1	
17	1CC-F3136-00	.外管 2 .TUBE, OUTER (RIGHT)	1	1	
18	4GU-F3145-00	.油封 .OIL SEAL	1	1	
19	5AP-F3153-00	.扣环 .RING, SNAP	1	1	
20	5WG-F3110-00	.内管组件 1 .INNER TUBE COMP.1	1	1	
21	5WG-F3141-00	.前叉弹簧 .SPRING, FRONT FORK	1	1	
22	5WG-F3170-00	.柄管缸套 .CYL.COMP.	1	1	
23	4GU-F3173-01	.锥形主轴 .SPINDLE, TAPER	1	1	
24	5LK-F3356-00	.螺栓 2 .BOLT 2	1	1	
25	4TU-F3479-00	.衬垫 .GASKET	1	1	
26	4KL-F3111-00	.顶盖螺栓 .BOLT, CAP	1	1	
27	5AP-F3147-00	.O型环 .O-RING	1	1	

FIG. 17 前叉

FRONT FORK

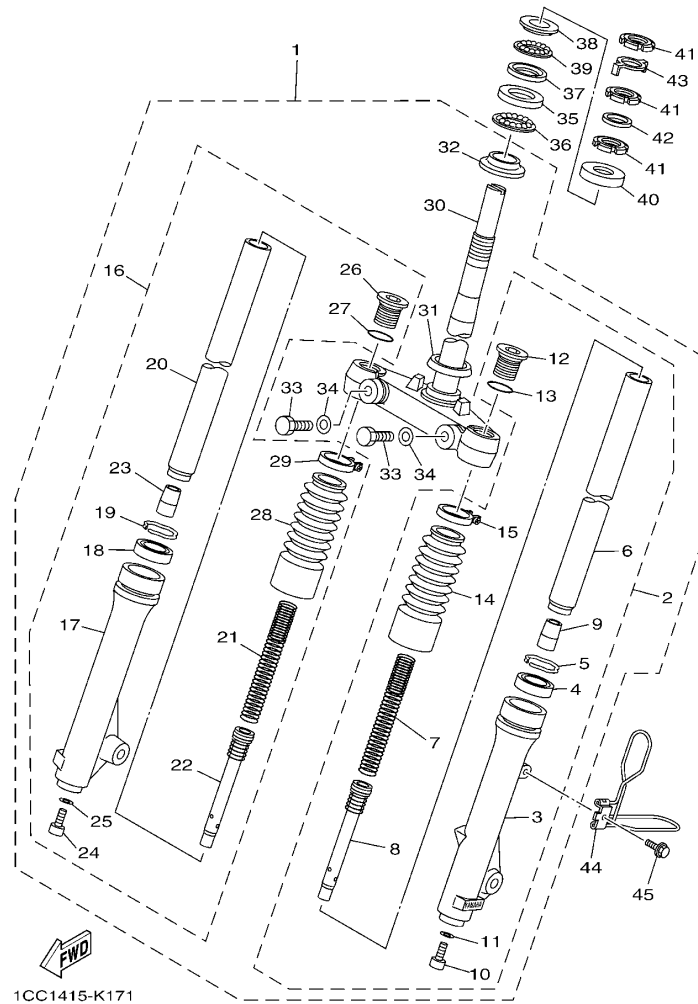

参照 号码	零件号码 PART NO.	零件名称 DESCRIPTION	1CCB	1CCC	备注 REMARKS
28	4KL-F3191-10	. 保护罩 .BOOT	1	1	
29	4KL-F3192-10	. 带箍 .BAND	1	1	
30	1CC-F3340-00	. 底托架组 .UNDER BRACKET COMP.	1	1	
31	4GU-F3462-00	. 方向柱密封圈 .SEAL, DUST	1	1	
32	4FP-F3411-10	. 滚珠座圈 1 .RACE, BALL 1	1	1	
33	4RT-F3346-00	. 螺栓 1 .BOLT 1	2	2	
34	4P7-F3843-00	. 平垫圈 .WASHER, PLAIN	2	2	
35	4KL-F3412-20	. 滚珠座圈 2 RACE, BALL 2	1	1	
36	5WG-F341E-00	. 保持架 RETAINER, BALL BEARING	1	1	
37	4KL-F3412-30	. 滚珠座圈 2 RACE, BALL 2	1	1	
38	4KL-F3411-10	. 滚珠座圈 1 RACE, BALL 1	1	1	
39	5WG-F341E-10	. 保持架 RETAINER, BALL BEARING	1	1	
40	5MH-F3416-01	. 滚珠座圈盖 2 COVER, BALL RACE 2	1	1	
41	90179-25810	. 螺母 NUT	3	3	
42	90202-26142	. 平垫圈 WASHER, PLATE	1	1	
43	5WG-F3418-01	. 专用垫圈 WASHER, SPECIAL	1	1	
44	1CC-F3317-10	. 钢索支架 HOLDER, CABLE	1	1	
45	95802-06012	. 凸缘螺栓 BOLT, FLANGE	1	1	

FIG. 18 油箱

FUEL TANK

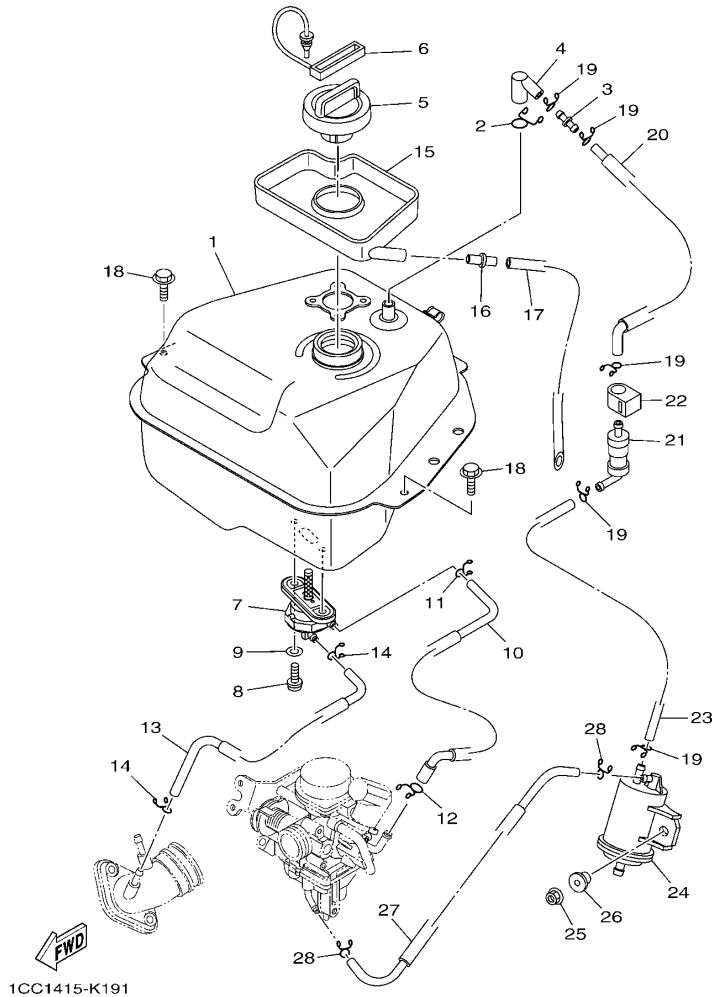

参照 号码	零件号码 PART NO.	零件名称 DESCRIPTION	TCCB	TCCC			备注 REMARKS
1	4S5-F4110-10	油箱组合 FUEL TANK COMP.	1	1			
2	90467-12802	卡环 CLIP	1	1			
3	4S0-F1753-00	连接器轴节 BOSS, CONNECTOR	1	1			
4	4S0-F4112-00	管 PIPE	1	1			
5	4S0-F4610-01	油箱盖总成 CAP ASSY	1	1			
6	5WY-F4633-00	滚珠链 CHAIN, BALL	1	1			
7	5WG-F4500-01	燃油开关组合 1 FUEL COCK ASSY 1	1	1			
8	90149-06108	螺钉 SCREW	2	2			
9	90202-05193	平垫圈 WASHER, PLATE	2	2			
10	4S0-F4311-11	燃油管 1 PIPE, FUEL 1	1	1			
11	90467-09006	卡环 CLIP	1	1			
12	90467-10008	卡环 CLIP	1	1			
13	4S0-F4312-10	管 2 PIPE 2	1	1			
14	90467-08003	卡环 CLIP	2	2			
15	5WG-F414A-00	加油器盖 COVER, FILLER	1	1			
16	5WY-F1753-00	连接器轴节 BOSS, CONNECTOR	1	1			
17	91A11-07048	软管 TUBE, FLEXUBLE	1	1			
18	95802-06014	凸缘螺栓 BOLT, FLANGE	2	2			
19	90467-09006	卡环 CLIP	5	5			
20	1CC-F4313-00	管 3 PIPE 3	1	1			
21	18C-F4180-00	滚动阀组合 ROLL OVER VALVE ASSY	1	1			
22	4S0-F4135-00	夹箍 1 CLAMP 1	1	1			
23	4S0-F4314-00	管 4 PIPE 4	1	1			
24	1CC-F4170-00	过滤缸总成 CANISTER ASSY	1	1			
25	95702-06500	螺母 NUT, FLANGE	1	1			
26	90387-068J2	轴套 COLLAR	1	1			
27	1CC-F4315-00	管 5 PIPE 5	1	1			



FIG. 18 油箱

FUEL TANK

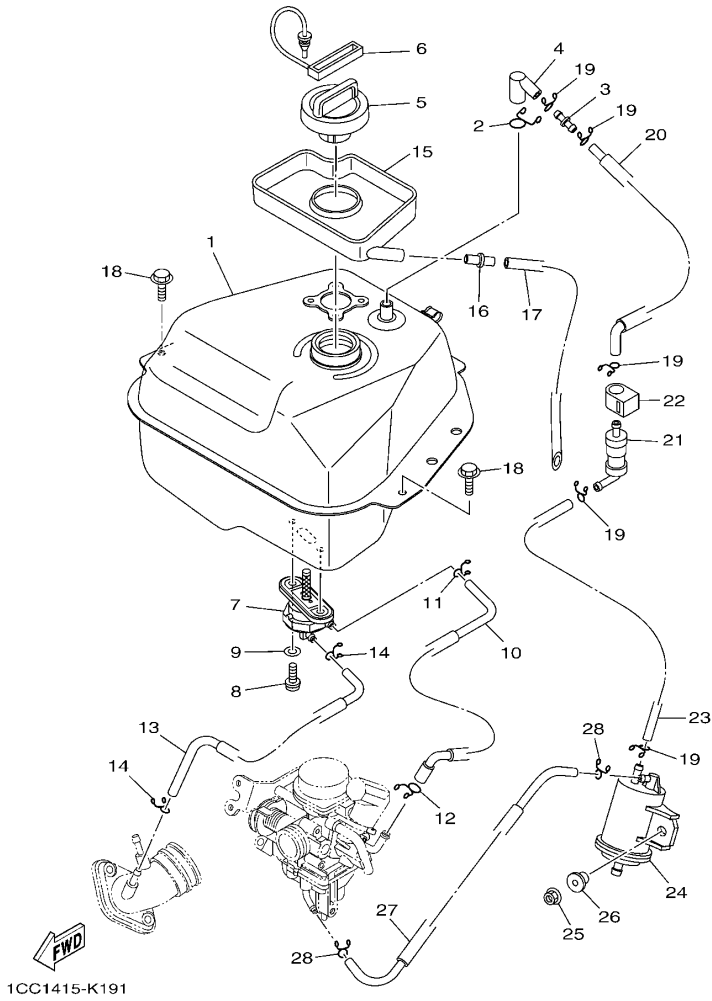

参照 号码	零件号码 PART NO.	零件名称 DESCRIPTION	1CCB	1CCC			备注 REMARKS
28	90467-08003	卡环 CLIP	2	2			

FIG. 19 座位

SEAT

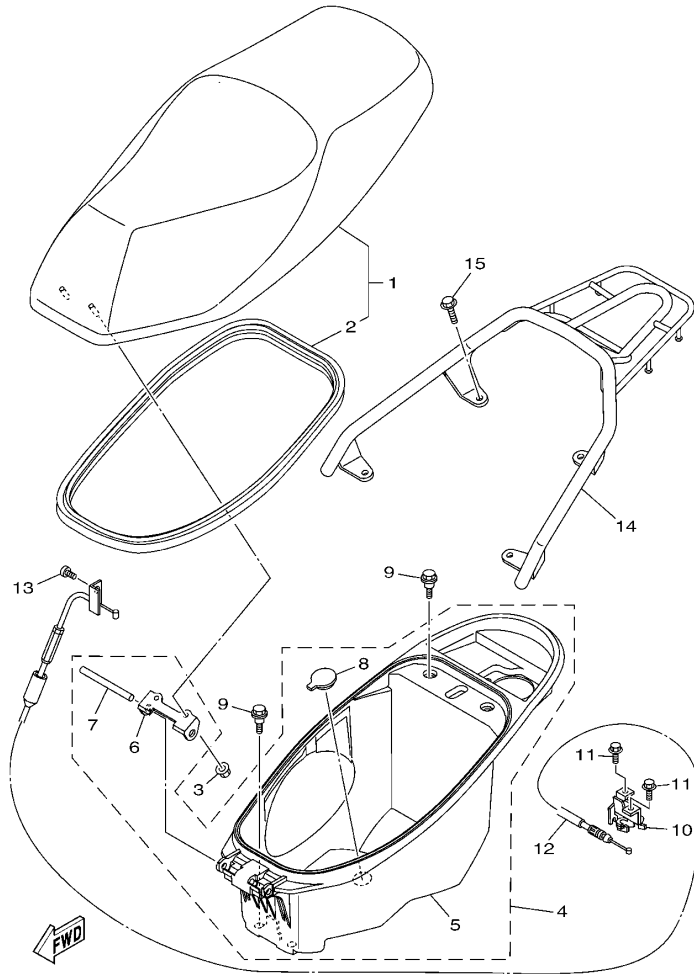

1CCB415-M190

参照 号码	零件号码 PART NO.	零件名称 DESCRIPTION	TCB	CCC			备注 REMARKS
1	1CC-F4730-00	双人座垫组合 DOUBLE SEAT ASSY	1	1			
2	1CC-F475M-00	.密封圈 .SEAL	1	1			
3	95702-06500	螺母 NUT, FLANGE	2	2			
4	1CC-X2473-00	置物箱组装总成 BOX 1 SUB ASSY	1	1			
5	1CC-F473R-00	.箱 1 .BOX 1	1	1			
6	1CC-F4726-00	.座位铰 .HINGE, SEAT	1	1			
7	1CC-F4727-00	.座位装配销 .PIN, SEAT FITTING	1	1			
8	5WY-F4742-00	.塞 .GROMMET	1	1			
9	90109-06822	螺栓 BOLT	4	4			
10	4S5-F4780-01	座位锁装置组合 SEAT LOCK ASSY	1	1			
11	95802-06010	凸缘螺栓 BOLT, FLANGE	2	2			
12	1CC-F478E-00	车座锁钢索 CABLE, SEAT LOCK	1	1			
13	98502-05012	十字螺钉 SCREW, PAN HEAD	1	1			
14	1CC-F4841-10	后载架 CARRIER, FRONT	1	1			
15	90119-08864	带垫螺栓 BOLT, WITH WASHER	4	4			

FIG. 20 前轮

FRONT WHEEL

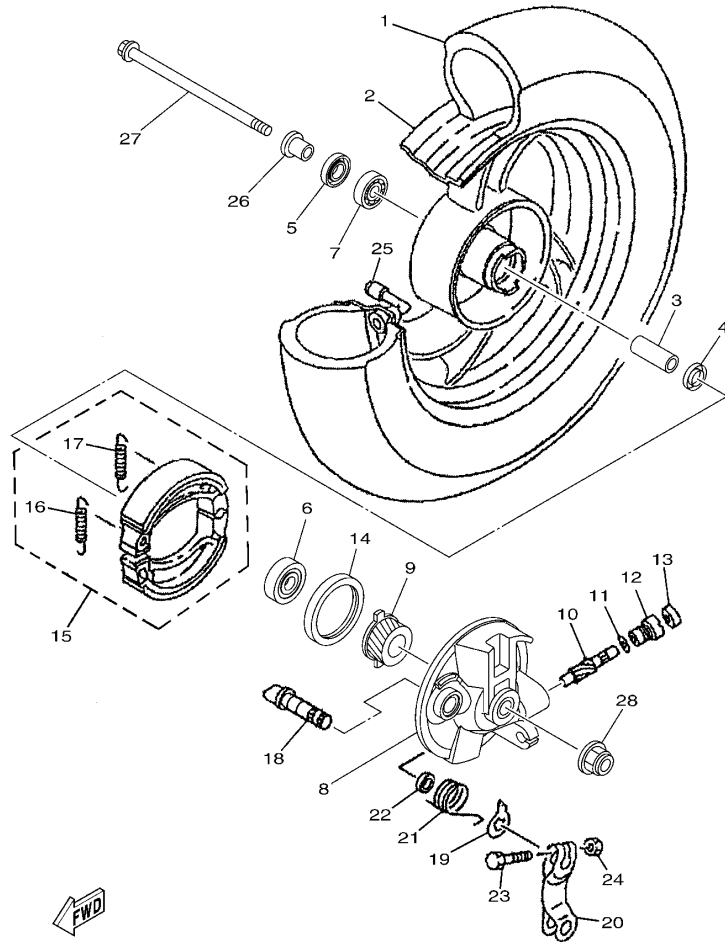

1CCB415-M200

参照 号码	零件号码 PART NO.	零件名称 DESCRIPTION	TCCB	TCCC	备注 REMARKS
1	94110-10810	轮胎 TIRE (100/90-10 C-922 56J TL)	1	1	CHENG SHIN 银色 SL
2	4KL-F5168-30-35	前压铸轮 CAST WHEEL, FRONT	1	1	
3	90560-12138	衬套 SPACER	1	1	
4	5WG-F5315-00	凸缘衬套 FLANGE, SPACER	1	1	
5	93102-17853	油封 OIL SEAL	1	1	
6	93306-301XV	轴承 BEARING	1	1	银色 SL
7	93306-201YA	轴承 BEARING	1	1	
8	4KL-F5121-20-35	前制动盖 PLATE, BRAKE SHOE	1	1	
9	5WG-F5135-00	主驱动齿轮 GEAR, DRIVE	1	1	
10	5WG-F5138-00	仪表齿轮 GEAR, METER	1	1	
11	90201-07076	平垫圈 WASHER, PLATE	1	1	
12	4KL-F5136-00	衬套 BUSH	1	1	
13	93104-07803	油封 OIL SEAL	1	1	
14	93106-47814	油封 OIL SEAL	1	1	
15	5WG-X2534-00	制动蹄块组合 BRAKE SHOE SET	1	1	
16	90506-12001	拉簧 .SPRING, TENSION	1	1	
17	90506-15001	拉簧 .SPRING, TENSION	1	1	
18	4KL-F5151-01	凸轮轴 CAMSHAFT	1	1	
19	4KL-F513A-01	指示器面板 PLATE, INDICATOR	1	1	
20	4KL-F5155-01	制动臂 1 LEVER, CAMSHAFT 1	1	1	
21	90508-26801	扭簧 SPRING, TORSION	1	1	
22	4KL-F5159-00	凸轮轴密封 SEAL, CAMSHAFT	1	1	
23	90101-06046	螺栓 BOLT	1	1	
24	95302-06600	螺母 NUT	1	1	
25	93900-00827	气门嘴 VALVE, RIM	1	1	
26	90387-128M1	轴套 COLLAR	1	1	
27	5WG-F5181-01	前轮轮轴 AXLE, WHEEL	1	1	

FIG. 20 前轮

FRONT WHEEL

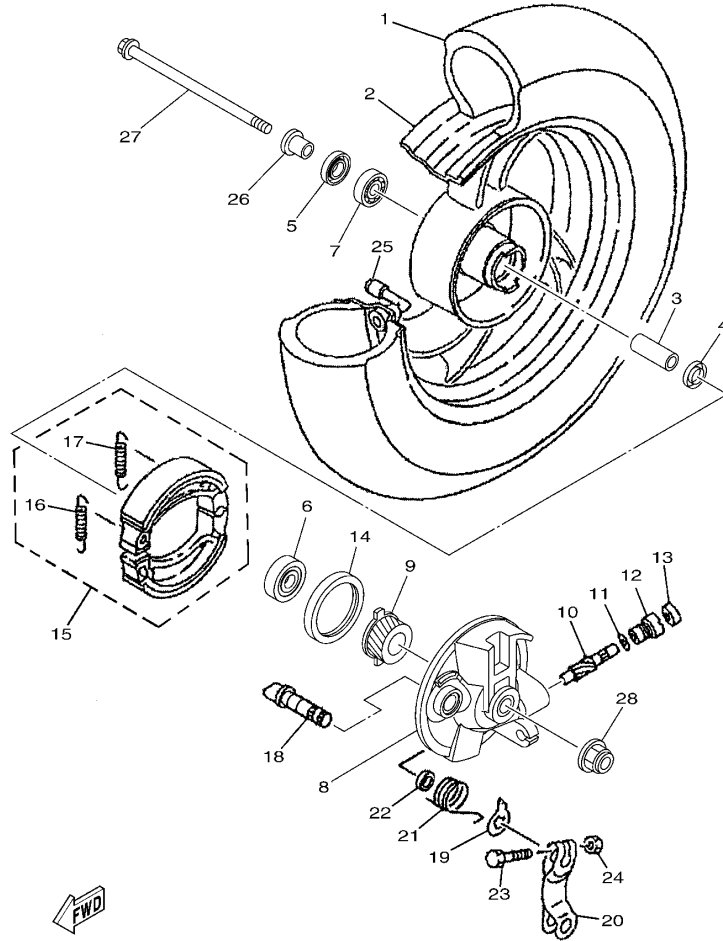

FWD  
1CCB415-M200

参照 号码	零件号码 PART NO.	零件名称 DESCRIPTION	TCCB	TCCC			备注 REMARKS
28	95602-12200	自锁螺母 NUT, SELF-LOCKING	1	1			

FIG. 21 后轮

REAR WHEEL

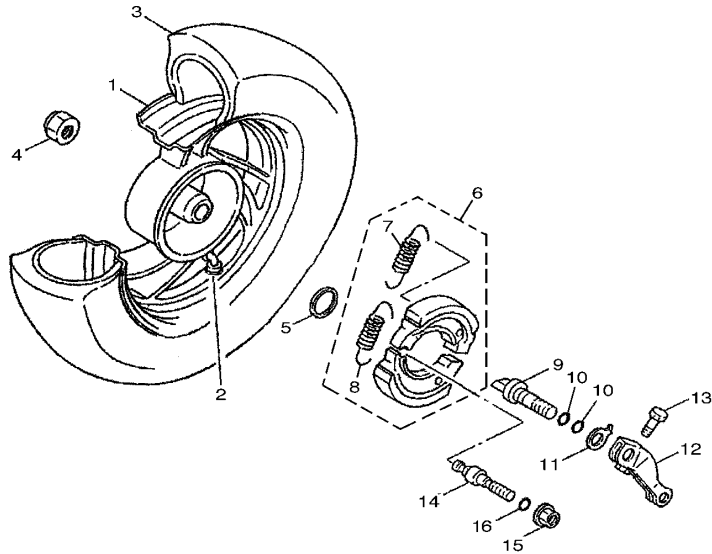

参照 号码	零件号码 PART NO.	零件名称 DESCRIPTION	TCCB	TCCC	备注 REMARKS
1	4KL-F5338-10-35	后压铸轮 CAST WHEEL, REAR	1	1	银色 SL
2	93900-00827	气门嘴 VALVE, RIM	1	1	
3	94110-10811	轮胎 TIRE (100/90-10 C-940 56J TL)	1	1	CHENG SHIN
4	90185-14807	自锁螺母 NUT, SELF-LOCKING	1	1	
5	90201-20819	平垫圈 WASHER, PLATE	1	1	
6	5WG-X2534-00	制动蹄块组合 BRAKE SHOE SET	1	1	
7	90506-12001	拉簧 .SPRING, TENSION	1	1	
8	90506-15001	拉簧 .SPRING, TENSION	1	1	
9	5WY-F5351-01	凸轮轴 CAMSHAFT	1	1	
10	93210-09859	O型环 O-RING	2	2	
11	5WY-F533A-01	指示片 PLATE, INDICATOR	1	1	
12	5WY-F5355-01	制动臂 LEVER, CAMSHAFT	1	1	
13	90101-06046	螺栓 BOLT	1	1	
14	5WG-F5326-01	枢轴 PIN, PIVOT	1	1	
15	95702-10500	螺母 NUT, FLANGE	1	1	
16	93210-07890	O型环 O-RING	1	1	

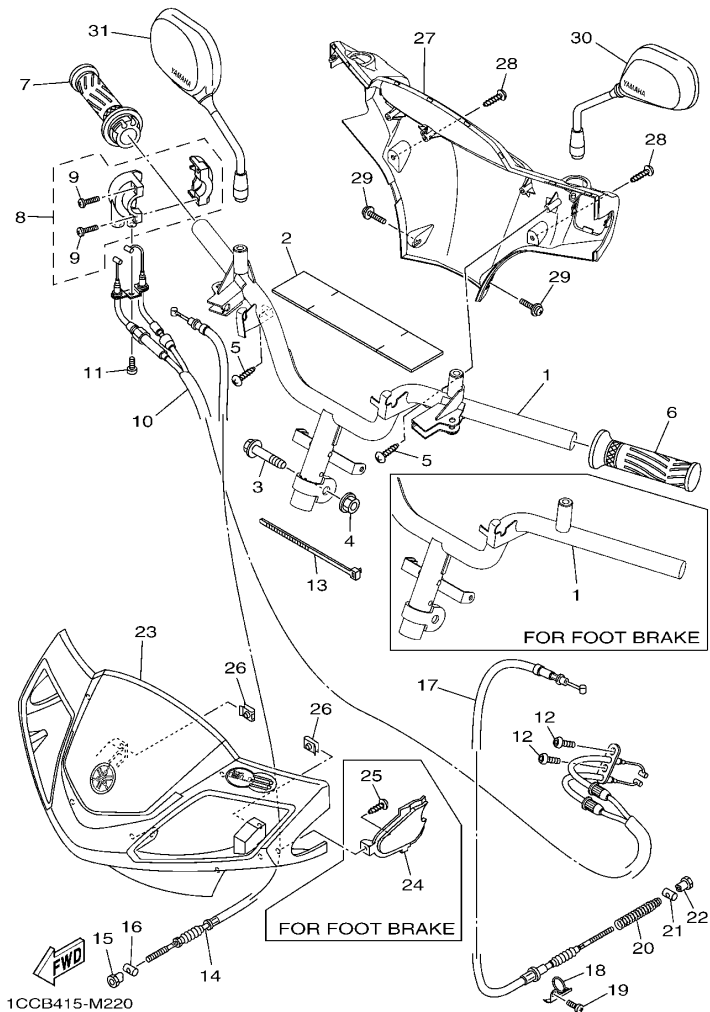

FIG. 22 操纵手柄·钢索

STEERING HANDLE & CABLE

参照 号码	零件号码 PART NO.	零件名称 DESCRIPTION	1CCB	1CCC	备注 REMARKS
1	1CC-F6110-00	手柄组件 HANDLE COMP.	1		
	1CC-F6110-30	手柄组件 HANDLE COMP.		1	
2	5WG-F6113-00	减震器 DAMPER	1	1	
3	90105-10839	凸缘螺栓 BOLT, FLANGE	1	1	
4	95602-10200	自锁螺母 NUT, U FLANGE	1	1	
5	97702-50016	自攻螺钉 SCREW, TAPPING	2	2	
6	1CC-F6241-00	握把 (左边) GRIP	1	1	
7	1CC-F6240-00	握把 (右边) GRIP ASSY	1	1	
8	4P7-F6270-01	钢索连接器盖组合 CAP GRIP ASSY	1	1	
9	98502-05020	十字螺钉 SCREW, PAN HEAD	2	2	
10	5WB-F6301-00	油门钢索组合 THROTTLE CABLE ASSY	1	1	
11	98502-05010	十字螺钉 SCREW, PAN HEAD	1	1	
12	92012-05010	螺钉 BOLT, BUTTON HEAD	2	2	
13	90464-20809	线夹 CLAMP	1	1	
14	1CC-F6341-00	制动拉索 1 WIRE, BRAKE 1	1	1	
15	90179-06843	螺母 NUT	1	1	
16	90249-12806	销 PIN	1	1	
17	1CC-F6351-00	制动器钢索 CABLE, BRAKE	1		
18	4KL-F637G-01	钢索支架 HOLDER, WIRE	1	1	
19	98502-06012	十字螺钉 SCREW, PAN HEAD	1	1	
20	90501-16831	压簧 SPRING, COMPRESSION	1	1	
21	90249-12806	销 PIN	1	1	
22	90179-06843	螺母 NUT	1	1	
23	1CC-X2610-30-P0	手柄杆上侧盖 1 COVER, HANDLEBAR UPPER 1	1	1	UR 金属黑色车用 UR FOR SMX
	1CC-X2610-30-P4	手柄杆上侧盖 1 COVER, HANDLEBAR UPPER 1	1	1	UR 浓红车用 UR FOR DRMK
	1CC-X2610-30-UG	手柄杆上侧盖 1 COVER, HANDLEBAR UPPER 1	1	1	UR 棕色车用 UR FOR IPB
	1CC-X2610-30-P5	手柄杆上侧盖 1 COVER, HANDLEBAR UPPER 1	1	1	UR 发紫浅蓝 3 车用 UR FOR PPBM3

FIG. 22 操纵手柄·钢索

STEERING HANDLE & CABLE

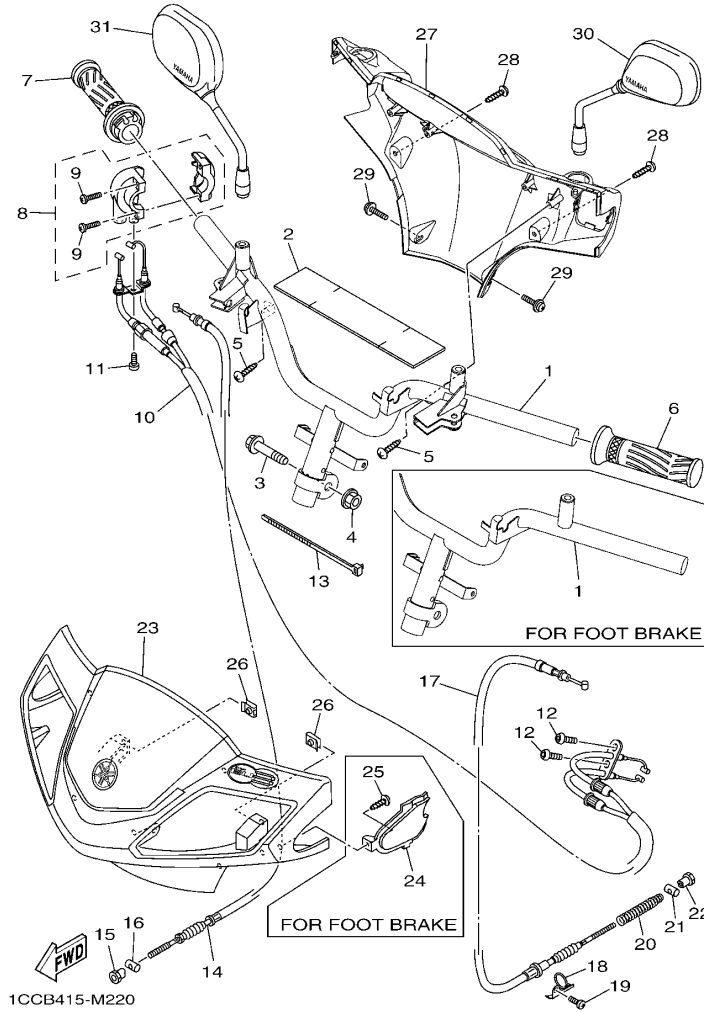

参照 号码	零件号码 PART NO.	零件名称 DESCRIPTION	TCCB	TCCC	备注 REMARKS
23	1CC-X2610-30-P3	手柄杆上侧盖 1 COVER, HANDLEBAR UPPER 1	1	1	UR 金属白车用 UR FOR WM1
24	1CC-F6477-00	盖 COVER		1	
25	97702-50016	自攻螺钉 SCREW, TAPPING		1	
26	90183-05818	弹性螺母 NUT, SPRING	2	2	
27	1CC-F6145-00	手柄杆上侧盖 2 COVER, HAND UPPER 2	1	1	
28	97702-50012	自攻螺钉 SCREW, TAPPING	2	2	
29	97602-05216	带垫圈大柱头螺钉 SCREW, PAN HEAD WITH WASHER	2	2	
30	5WY-F6280-40	后视镜组合 (左边) REAR VIEW MIRROR ASSY (LEFT)	1	1	
31	5WY-F6290-40	后视镜组合 (右边) REAR VIEW MIRROR ASSY (RIGHT)	1	1	

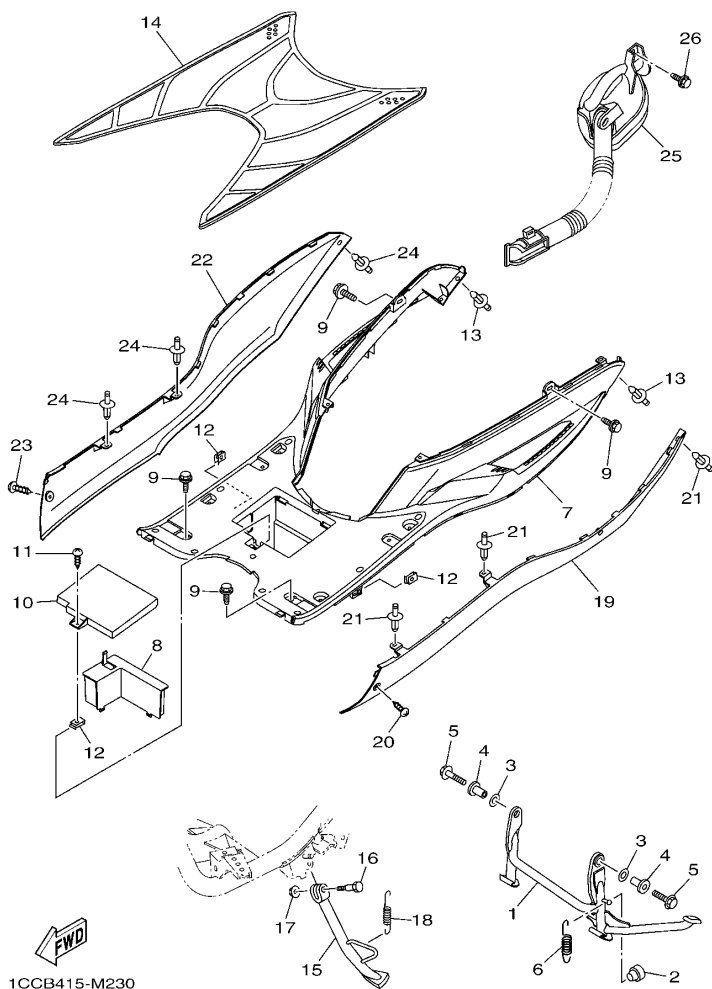

1CCB415-M230

FIG. 23 搁脚·支架

STAND & FOOTREST

参照 号码	零件号码 PART NO.	零件名称 DESCRIPTION	TCCB	TCCC		备注 REMARKS
1	1CC-F7111-10	主支承 STAND, MAIN	1			
2	4KL-F7314-00	限位板 STOPPER	1			
3	90202-15804	平垫圈 WASHER, PLATE	2			
4	5WG-F7113-01	主支承安装 COLLAR, MAIN STAND	2			
5	95812-10035	凸缘螺栓 BOLT, FLANGE	2			
6	90506-35820	拉簧 SPRING, TENSION	1			
7	1CC-F7481-00	搁脚踏板 BOARD, FOOTREST	1			
8	1CC-H252H-00	支架 PLATE, HOLDER	1			
9	90119-06157	带垫螺栓 BOLT, WITH WASHER	6			
10	1CC-H2129-00	蓄电池盖 COVER, BATTERY	1			
11	97702-50012	自攻螺钉 SCREW, TAPPING	1			
12	90183-05818	弹性螺母 NUT, SPRING	3			
13	90269-06809	铆钉 RIVET	2			
14	1CC-F7483-00	衬垫 1 MAT 1	1			
15	4S5-F7311-10	侧支承 STAND, SIDE	1			
16	90109-08836	螺栓 BOLT	1			
17	95602-08200	自锁螺母 NUT, SELF-LOCKING	1			
18	90506-20816	拉簧 SPRING, TENSION	1			
19	1CC-F7482-00-P2	护腿板嵌条 MOLD, FOOTREST	1			UR 金属黑色车用 UR FOR SMX
	1CC-F7482-00-P4	护腿板嵌条 MOLD, FOOTREST	1			UR 浓红车用 UR FOR DRMK
	1CC-F7482-00-UG	护腿板嵌条 MOLD, FOOTREST	1			UR 棕色车用 UR FOR IPB
	1CC-F7482-00-P5	护腿板嵌条 MOLD, FOOTREST	1			UR 发紫浅蓝 3 车用 UR FOR PPBM3
	1CC-F7482-00-P3	护腿板嵌条 MOLD, FOOTREST	1			UR 金属白车用 UR FOR WM1
20	97702-50012	自攻螺钉 SCREW, TAPPING	1			
21	90269-06809	铆钉 RIVET	3			
22	1CC-F7492-00-P2	护腿板嵌条 2 MOLD, FOOTREST 2	1			UR 金属黑色车用 UR FOR SMX
	1CC-F7492-00-P4	护腿板嵌条 2 MOLD, FOOTREST 2	1			UR 浓红车用 UR FOR DRMK



FIG. 23 搁脚·支架

STAND & FOOTREST

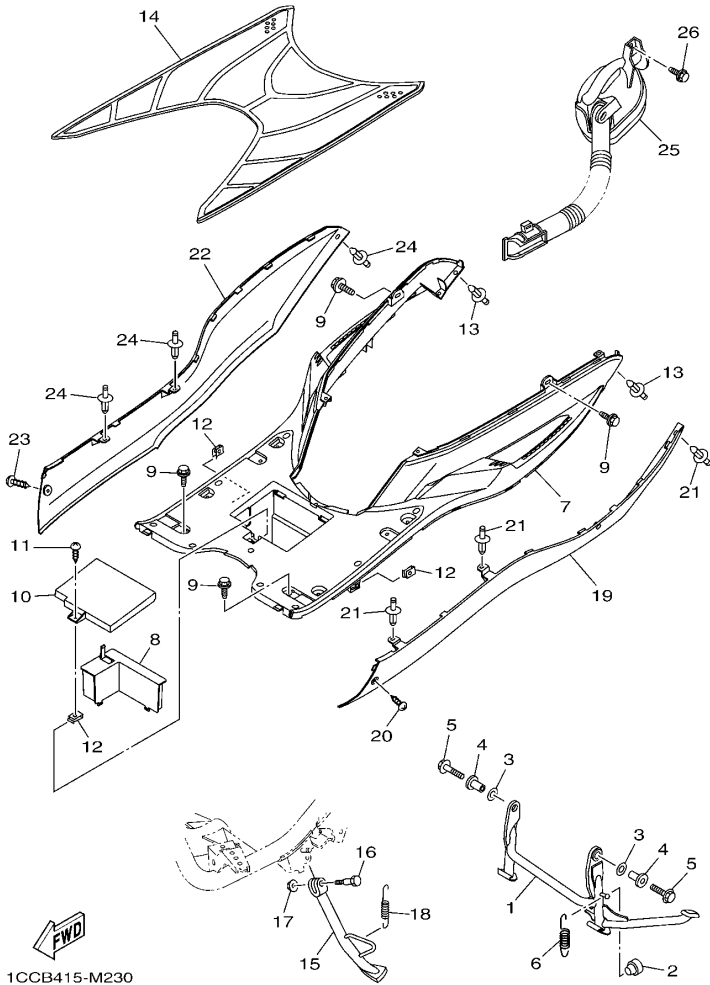

参照 号码	零件号码 PART NO.	零件名称 DESCRIPTION	1CCB	1CCC	备注 REMARKS
22	1CC-F7492-00-UG	护腿板嵌条 2 MOLD, FOOTREST 2	1		UR 棕色车用 UR FOR IPB UR 发紫浅蓝 3 车用 UR FOR PPBM3 UR 金属白车用 UR FOR WM1
	1CC-F7492-00-P5	护腿板嵌条 2 MOLD, FOOTREST 2	1		
	1CC-F7492-00-P3	护腿板嵌条 2 MOLD, FOOTREST 2	1		
23	97702-50012	自攻螺钉 SCREW, TAPPING	1		
24	90269-06809	铆钉 RIVET	3		
25	1CC-F1690-00	防护板 FLAP COMP.	1		
26	90119-06157	带垫螺栓 BOLT, WITH WASHER	1		

FIG. 24 搁脚·支架 2

STAND & FOOTREST 2

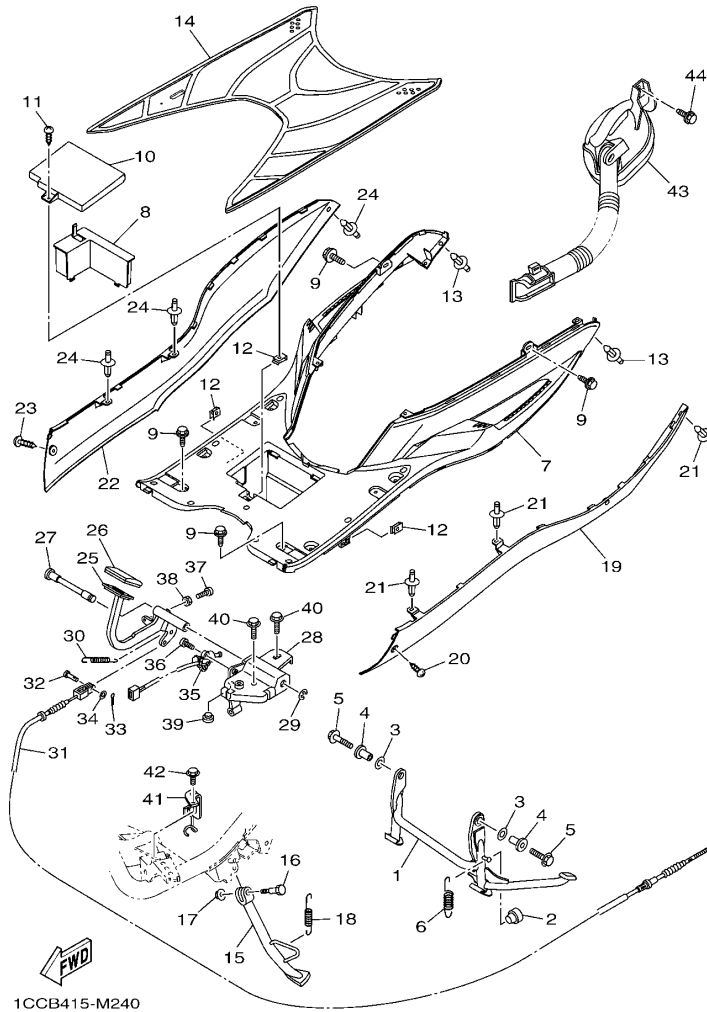

1CCB415-M240

参照 号码	零件号码 PART NO.	零件名称 DESCRIPTION	1CCB	1CCC	备注 REMARKS
1	1CC-F7111-10	主支承 STAND, MAIN		1	
2	4KL-F7314-00	限位板 STOPPER		1	
3	90202-15804	平垫圈 WASHER, PLATE		2	
4	5WG-F7113-01	主支承安装 COLLAR, MAIN STAND		2	
5	95812-10035	凸缘螺栓 BOLT, FLANGE		2	
6	90506-35820	拉簧 SPRING, TENSION		1	
7	1CC-F7481-00	搁脚踏板 BOARD, FOOTREST		1	
8	1CC-H252H-00	支架 PLATE, HOLDER		1	
9	90119-06157	带垫螺栓 BOLT, WITH WASHER		6	
10	1CC-H2129-00	蓄电池盖 COVER, BATTERY		1	
11	97702-50012	自攻螺钉 SCREW, TAPPING		1	
12	90183-05818	弹性螺母 NUT, SPRING		3	
13	90269-06809	铆钉 RIVET		2	
14	1CC-F7483-10	衬垫 1 MAT 1		1	
15	4S5-F7311-10	侧支承 STAND, SIDE		1	
16	90109-08836	螺栓 BOLT		1	
17	95602-08200	自锁螺母 NUT, SELF-LOCKING		1	
18	90506-20816	拉簧 SPRING, TENSION		1	
19	1CC-F7482-00-P2	护腿板嵌条 MOLD, FOOTREST		1	UR 金属黑色车用 UR FOR SMX
	1CC-F7482-00-P4	护腿板嵌条 MOLD, FOOTREST		1	UR 浓红车用 UR FOR DRMK
	1CC-F7482-00-UG	护腿板嵌条 MOLD, FOOTREST		1	UR 棕色车用 UR FOR IPB
	1CC-F7482-00-P5	护腿板嵌条 MOLD, FOOTREST		1	UR 发紫浅蓝 3 车用 UR FOR PPBM3
	1CC-F7482-00-P3	护腿板嵌条 MOLD, FOOTREST		1	UR 金属白车用 UR FOR WM1
20	97702-50012	自攻螺钉 SCREW, TAPPING		1	
21	90269-06809	铆钉 RIVET		3	
22	1CC-F7492-00-P2	护腿板嵌条 2 MOLD, FOOTREST 2		1	UR 金属黑色车用 UR FOR SMX
	1CC-F7492-00-P4	护腿板嵌条 2 MOLD, FOOTREST 2		1	UR 浓红车用 UR FOR DRMK

FIG. 24 搁脚·支架 2

STAND & FOOTREST 2

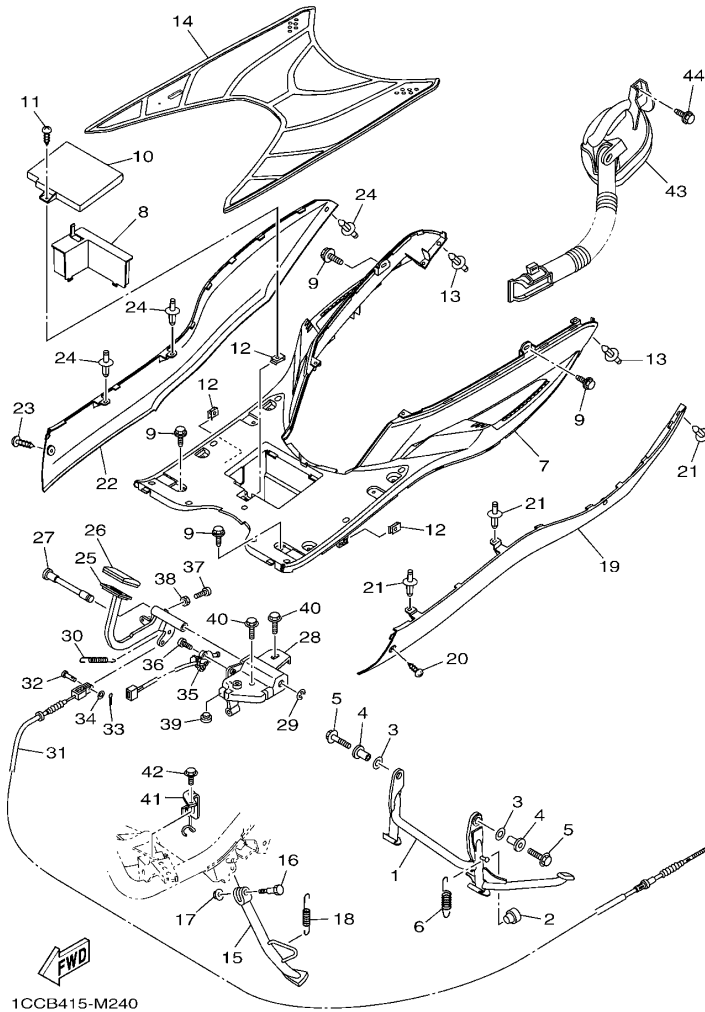

参照 号码	零件号码 PART NO.	零件名称 DESCRIPTION	ICCB	ICCC	备注 REMARKS
22	1CC-F7492-00-UG	护腿板嵌条 2 MOLD, FOOTREST 2		1	UR 棕色车用 UR FOR IPB
	1CC-F7492-00-P5	护腿板嵌条 2 MOLD, FOOTREST 2		1	UR 发紫浅蓝 3 车用 UR FOR PPBM3
	1CC-F7492-00-P3	护腿板嵌条 2 MOLD, FOOTREST 2		1	UR 金属白车用 UR FOR WM1
23	97702-50012	自攻螺钉 SCREW, TAPPING		1	
24	90269-06809	铆钉 RIVET		3	
25	1CC-F7211-00	制动踏板 PEDAL, BRAKE		1	
26	1CC-F7285-00	盖 CAP		1	
27	1CC-F7212-00	制动踏板轴 SHAFT, BRAKE PEDAL		1	
28	1CC-F7263-00	托架 1 BRACKET 1		1	
29	99002-09600	卡环 CLIP		1	
30	90506-14803	拉簧 SPRING, TENSION		1	
31	1CC-F6361-00	制动器钢索 CABLE, BRAKE		1	
32	90240-06804	销 PIN, CLEVIS		1	
33	91402-20012	开口销 PIN, COTTER		1	
34	92902-06200	垫圈 WASHER		1	
35	5MH-H2566-11	开关侧支承 SWITCH, SIDE STAND		1	
36	90157-05029	大柱头螺钉 SCREW, PAN HEAD		2	
37	90154-06004	夹紧螺钉 SCREW, BINDING		1	
38	90170-06020	螺母 NUT		1	
39	5MH-F7114-00	主支承限位板 STOPPER, MAIN STAND		1	
40	95802-10014	凸缘螺栓 BOLT, FLANGE		2	
41	5MH-F637G-01	钢索支架 HOLDER, WIRE		1	
42	95802-06010	凸缘螺栓 BOLT, FLANGE		1	
43	1CC-F1690-00	防护板 FLAP COMP.		1	
44	90119-06157	带垫螺栓 BOLT, WITH WASHER		1	

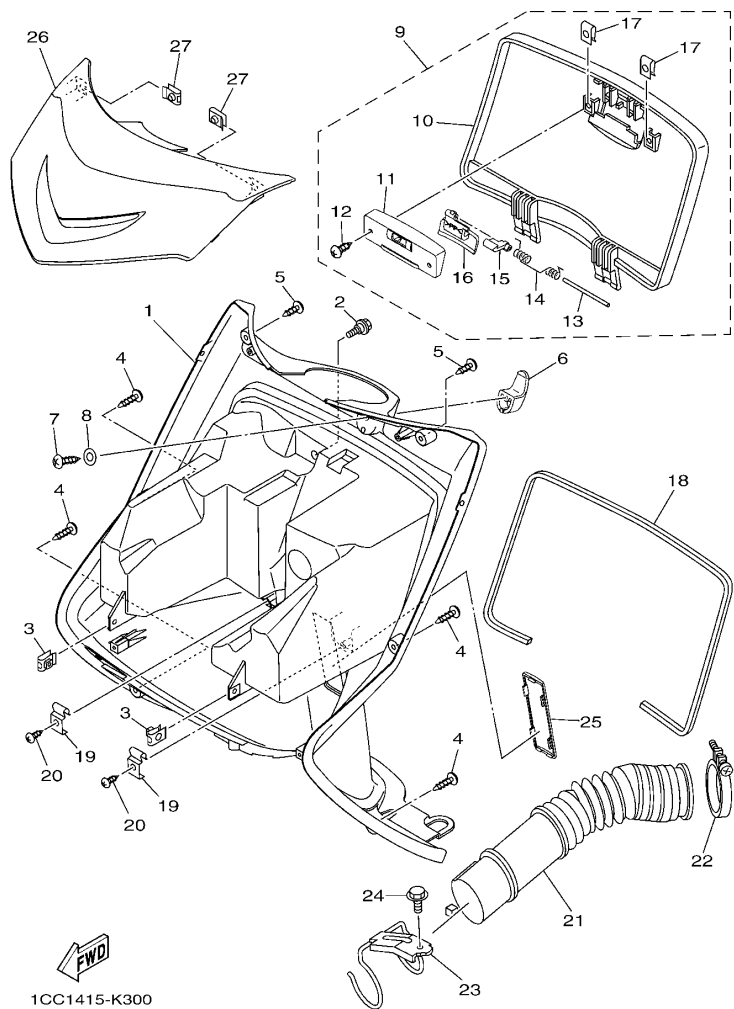

1CC1415-K300

FIG. 25 护腿

LEG SHIELD

参照 号码	零件号码 PART NO.	零件名称 DESCRIPTION	TCCB	TCCC	备注 REMARKS
1	1CC-F8312-00	护腿板 2 LEG SHIELD 2	1		
	1CC-F8312-10	护腿板 2 LEG SHIELD 2		1	
2	90109-06822	螺栓 BOLT	1	1	
3	90183-05819	弹性螺母 NUT, SPRING	2	2	
4	97702-50016	自攻螺钉 SCREW, TAPPING	4	4	
5	97702-50012	自攻螺钉 SCREW, TAPPING	2	2	
6	1CC-F8257-00	钩 1 HOOK 1	1	1	
7	97702-50016	自攻螺钉 SCREW, TAPPING	1	1	
8	90201-06814	平垫圈 WASHER, PLATE	1	1	
9	1CC-F83N0-00	前置物箱盖 LID ASSY	1	1	
10	1CC-F8313-00	.盖 .LID	1	1	
11	1CC-F8365-00	.盖 .COVER	1	1	
12	97702-50010	.自攻螺钉 .SCREW, TAPPING	2	2	
13	93603-70800	.定位销 .PIN, DOWEL	1	1	
14	1CC-F8388-00	.弹簧 .SPRING	1	1	
15	1CC-F8379-00	.挂钩 .HOOK	1	1	
16	1CC-F833B-00	.杠杆 .LEVER, HOLDER	1	1	
17	90183-05807	.弹性螺母 .NUT, SPRING	2	2	
18	90520-05807	减震垫 DAMPER	1	1	
19	1CC-F837F-00	转轴, 铰 HINGE	2	2	
20	97702-40512	自攻螺钉 SCREW, TAPPING	2	2	
21	5WG-F1557-00	空气管道 DUCT, AIR	1	1	
22	5WG-F1823-02	软管夹 CLAMP, HOSE	1	1	
23	5WG-F1161-01	钢索支架 HOLDER, CABLE	1	1	
24	95802-06012	凸缘螺栓 BOLT, FLANGE	1	1	
25	1CC-F8349-01	盖 CAP	1	1	
26	1CC-F8345-00-P0	嵌条 1 MOLE 1	1	1	金属黑色 SMX

FIG. 25 护腿

LEG SHIELD

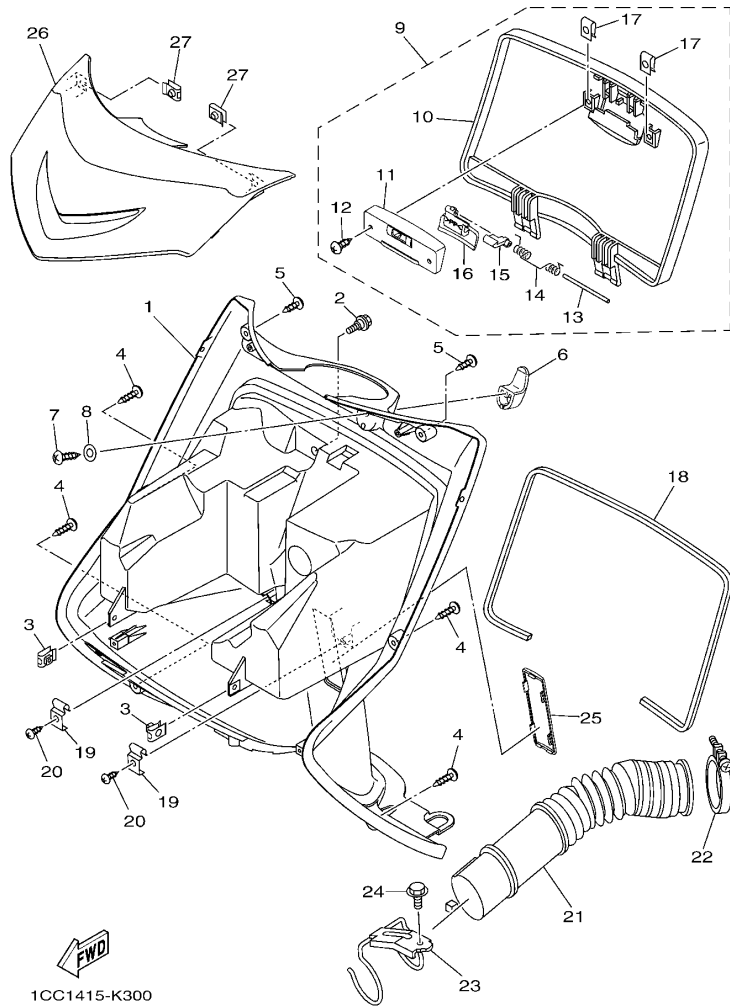

参照 号码	零件号码 PART NO.	零件名称 DESCRIPTION	TCRB	TCCC		备注 REMARKS
27	90183-05818	弹性螺母 NUT, SPRING	2	2		

FIG. 26 发电机

GENERATOR

参照 号码	零件号码 PART NO.	零件名称 DESCRIPTION	TCCB	TCCC				备注 REMARKS
1	5WY-H1450-01	转子组合 ROTOR ASSY	1	1				
2	5WY-H1410-11	定子组合 STATOR ASSY	1	1				
3	98502-06016	十字螺钉 SCREW, PAN HEAD	2	2				
4	90387-12853	轴套 COLLAR	1	1				
5	90170-12181	螺母 NUT	1	1				
6	97602-06225	带垫圈大柱头螺钉 SCREW, PAN HEAD WITH WASHER	3	3				

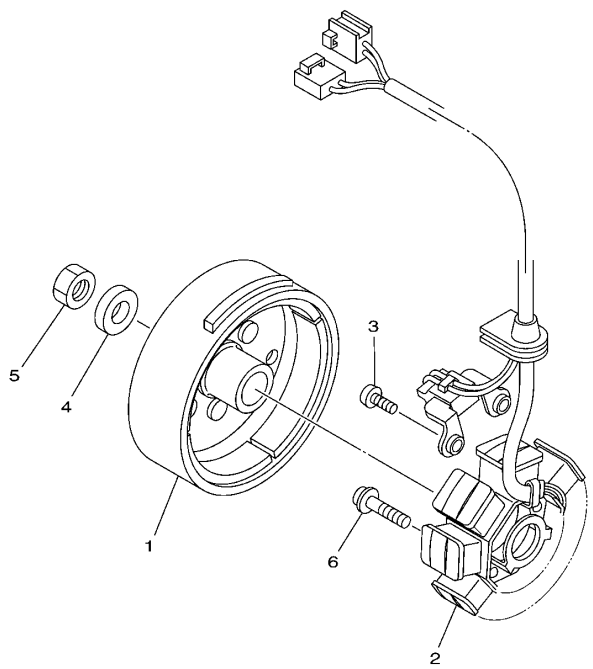

1CC1415-K310

FIG. 27 启动电机

STARTING MOTOR

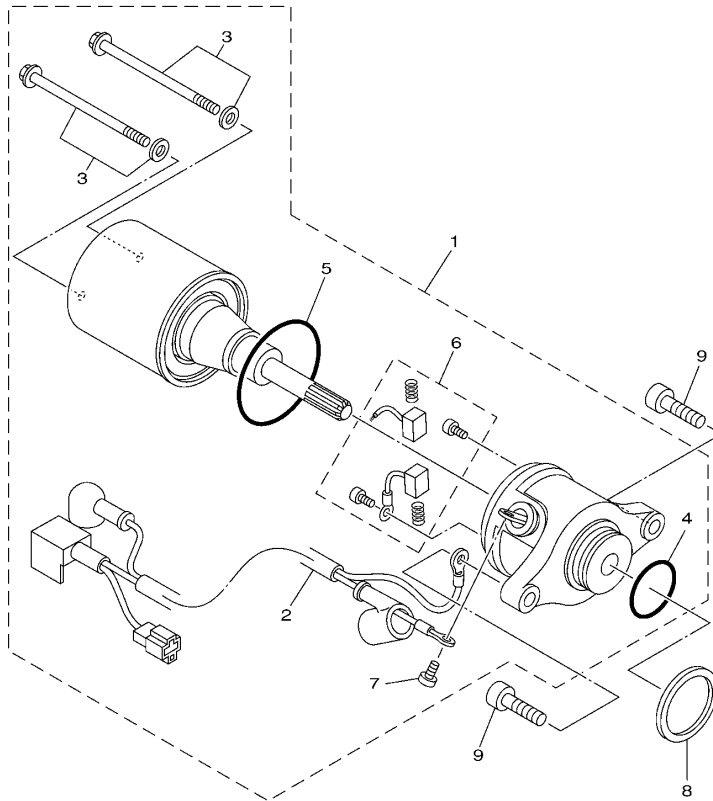

参照 号码	零件号码 PART NO.	零件名称 DESCRIPTION	TCCB	TCCC	备注 REMARKS
1	1CC-H1800-01	启动电机组合 STARTING MOTOR ASSY	1	1	
2	1CC-H183G-00	.导线组件 .CORD COMP.	1	1	
3	5WV-H1828-01	.组合螺钉 .SCREW 2	2	2	
4	93210-23614	.O型环 .O-RING	1	1	
5	93210-44678	.O型环 .O-RING	1	1	
6	4RT-H1801-00	.碳刷组件 .BRUSH SET	1	1	
7	98902-05008	.十字槽盘头螺钉 .SCREW, BIND	1	1	
8	90202-26801	平垫圈 WASHER, PLATE	1	1	
9	91312-06020	螺栓 BOLT	2	2	



1CC1415-K320

FIG. 28 转向灯

FLASHER LIGHT

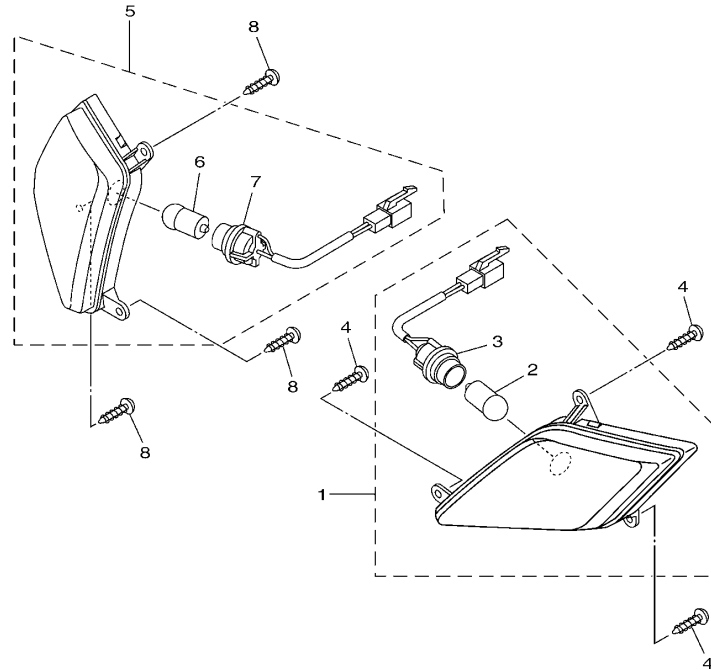

参照 号码	零件号码 PART NO.	零件名称 DESCRIPTION	TCB	ICC		备注 REMARKS
1	1CC-H3310-00	前转向灯组合 1 FRONT FLASHER LIGHT ASSY 1	1	1		
2	1CC-H3311-10	.转向灯灯泡 .BULB, FLASHER (12V-R10W)	1	1		
3	1CC-H331E-00	.缆索组合 .CORD ASSY	1	1		
4	97702-50016	自攻螺钉 SCREW, TAPPING	3	3		
5	1CC-H3320-00	前转向灯组合 2 FRONT FLASHER LIGHT ASSY 2	1	1		
6	1CC-H3311-10	.转向灯灯泡 .BULB, FLASHER (12V-R10W)	1	1		
7	1CC-H332E-00	.缆索组合 .CORD ASSY	1	1		
8	97702-50016	自攻螺钉 SCREW, TAPPING	3	3		

  
 1CC5415-K280



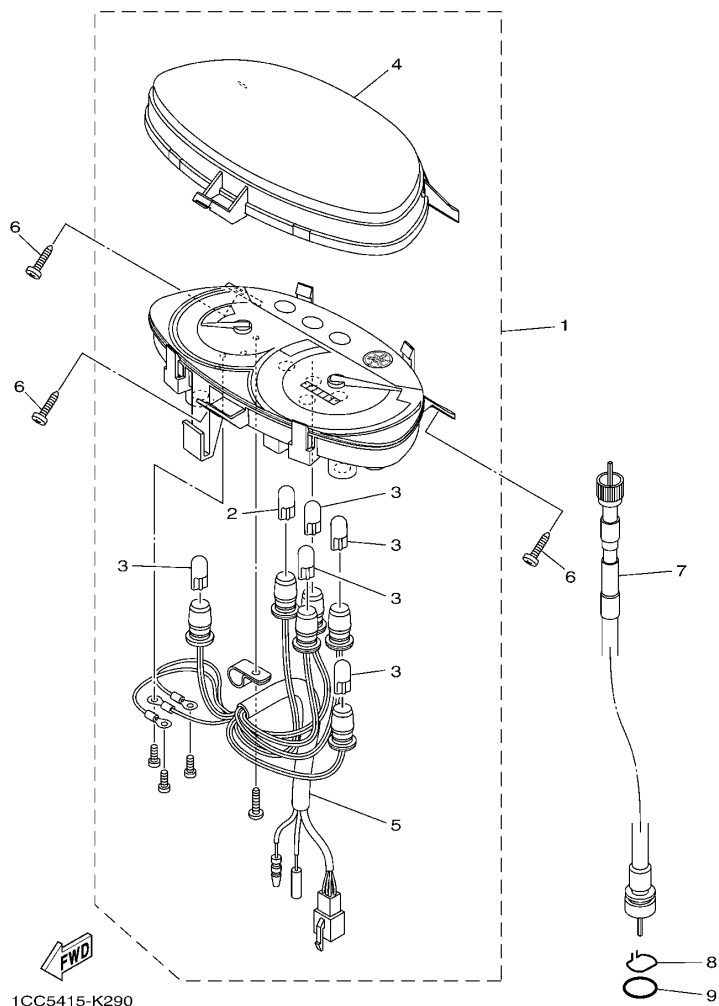

FIG. 29 仪表

METER

参照 号码	零件号码 PART NO.	零件名称 DESCRIPTION	TCCB	TCCC			备注 REMARKS
1	1CC-H3510-20	测速计组合 SPEEDOMETER ASSY	1	1			
2	1CC-H3517-10	. 灯泡 (T10 12V-3.4W) . BULB (T10 12V-3.4W)	1	1			
3	1CC-H3517-00	. 灯泡 (T10 12V-1.7W) . BULB (T10 12V-1.7W)	5	5			
4	1CC-H353K-00	. 玻璃面板 . GLASS PLATE	1	1			
5	1CC-H3509-00	. 导线组合 . SOCKET CORD ASSY	1	1			
6	97702-50016	自攻螺钉 SCREW, TAPPING	3	3			
7	1CC-H3550-00	速度计软轴组合 SPEEDOMETER CABLE ASSY	1	1			
8	4KL-F5137-21	止动环 RING, STOP	1	1			
9	93210-14104	0 型环 O-RING	1	1			

FIG. 30 前大灯

HEADLIGHT

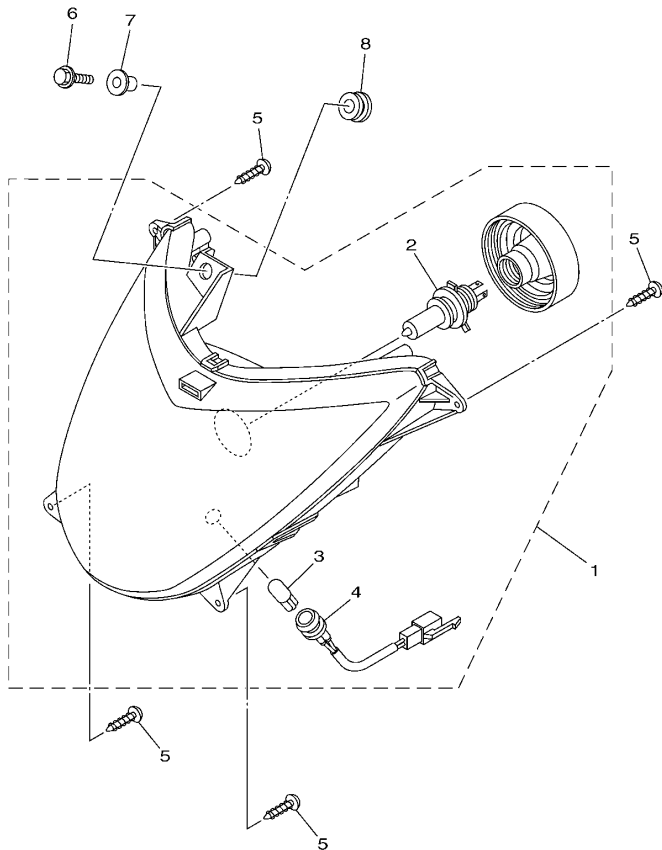

参照 号码	零件号码 PART NO.	零件名称 DESCRIPTION	TCB	CCC			备注 REMARKS
1	1CC-H4310-00	大灯组件 HEADLIGHT UNIT ASSY	1	1			
2	4S5-H4314-00	.前照灯灯泡 (12V-35/35W) .BULB, HEADLIGHT (12V-35/35W)	1	1			
3	1CC-H4347-00	.灯泡 (12V-5W) .BULB (12V-5W)	1	1			
4	1CC-H4312-00	.导线组合 .CORD ASSY	1	1			
5	97702-60020	自攻螺钉 SCREW, TAPPING	4	4			
6	95802-06020	凸缘螺栓 BOLT, FLANGE	1	1			
7	90387-06160	轴套 COLLAR	1	1			
8	90480-13398	橡胶垫 GROMMET	1	1			

 1CC1415-K360

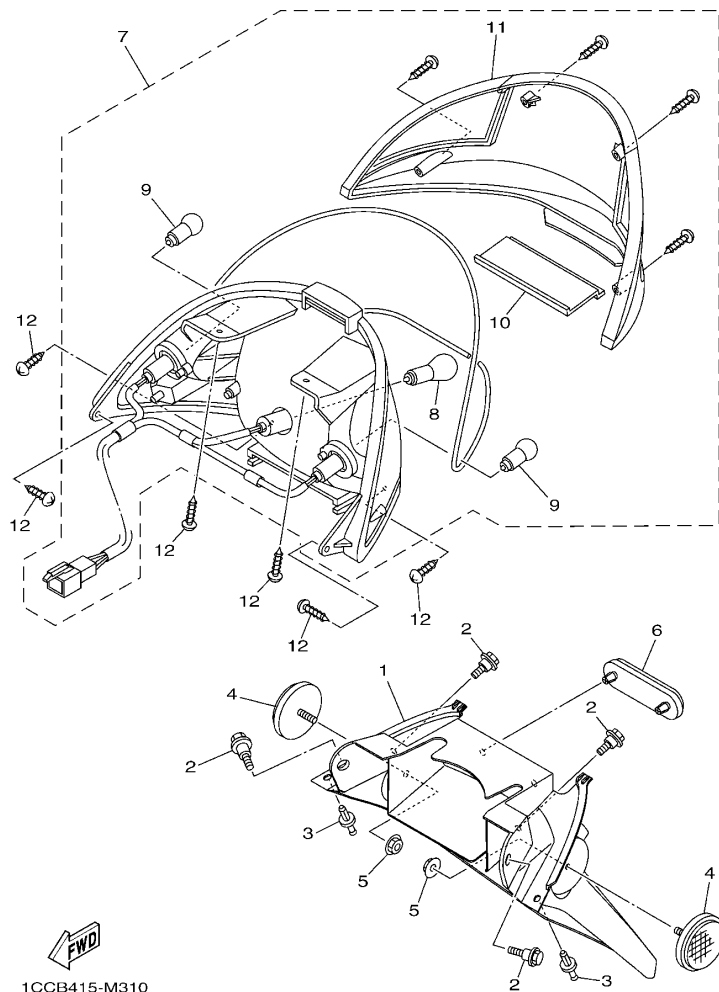

FIG. 31 尾灯

TAILLIGHT

参照 号码	零件号码 PART NO.	零件名称 DESCRIPTION	TCB	CCC	备注 REMARKS
1	1CC-F1685-00	车牌托架 BRACKET, LICENSE	1	1	
2	90109-06822	螺栓 BOLT	4	4	
3	90269-06809	铆钉 RIVET	2	2	
4	4KL-H5131-20	后反射镜 1 REFLECTOR, REAR 1	2	2	
5	95602-05200	自锁螺母 NUT, SELF-LOCKING	2	2	
6	1CC-H5130-00	后反射镜组合 REAR REFLECTOR ASSY	1	1	
7	1CC-H4700-10	尾灯组合 TAILLIGHT ASSY	1	1	
8	4KL-H4714-20	灯泡 (12V-21/5W) .BULB (12V-21/5W)	1	1	
9	1CC-H3311-10	转向灯灯泡 .BULB, FLASHER (12V-R10W)	2	2	
10	1CC-H4743-00	牌照灯镜头 .LENS, LICENCE LIGHT	1	1	
11	1CC-H4540-10	镜面组合 .LENS ASSY	1	1	
12	97702-50016	自攻螺钉 SCREW, TAPPING	6	6	

FIG. 32 手柄开关·杆

HANDLE SWITCH & LEVER

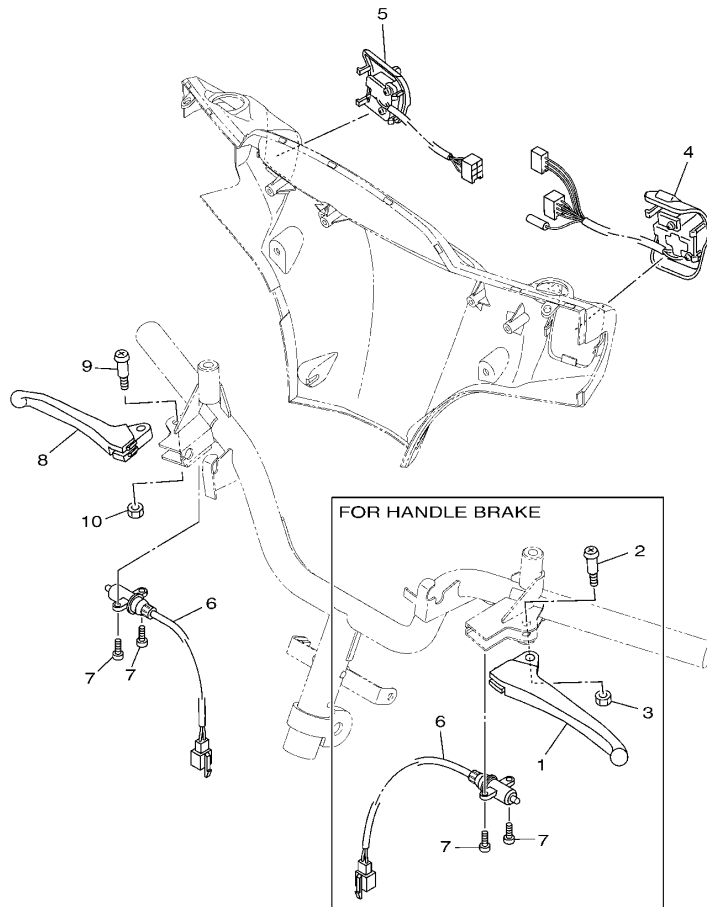

1CC1415-K380

参照 号码	零件号码 PART NO.	零件名称 DESCRIPTION	TCCB	TCCC			备注 REMARKS
1	5WY-H3912-20	手柄 1 LEVER 1	1				
2	90157-05812	大柱头螺钉 SCREW, PAN HEAD	1				
3	95602-05100	锁紧螺母 NUT, U	1				
4	4S0-H3963-01	手把开关 3 (右边) SWITCH, HANDLE 3	1	1			
5	4S0-H3975-01	手把开关 2 SWITCH, HANDLE 2	1	1			
6	1CC-H3980-10	前制动开关组合 FRONT STOP SWITCH ASSY	2	1			
7	98502-03008	十字螺钉 SCREW, PAN HEAD	4	2			
8	5WG-H3922-01	手柄 2 LEVER 2	1	1			
9	90157-05812	大柱头螺钉 SCREW, PAN HEAD	1	1			
10	95602-05100	锁紧螺母 NUT, U	1	1			

FIG. 33 电气系统 1

ELECTRICAL 1

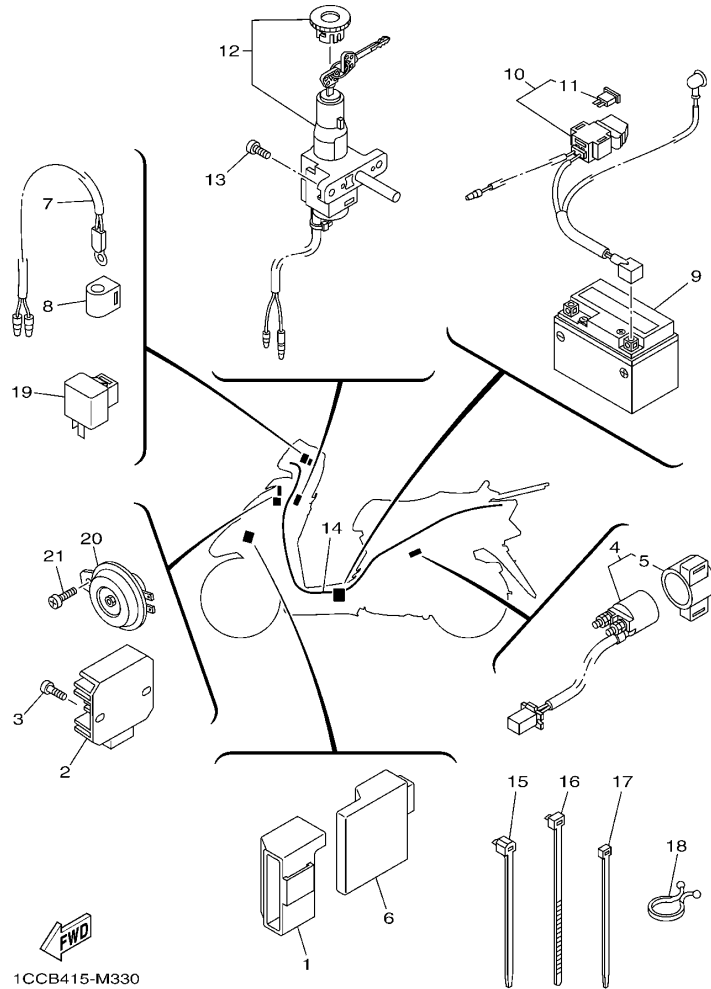

1CCB415-M330

参照 号码	零件号码 PART NO.	零件名称 DESCRIPTION	TCOB	TCOC				备注 REMARKS
1	4S0-H5546-00	箍带 BAND	1	1				
2	5WY-H1960-10	整流调节器 RECTIFIER & REGULATOR ASSY	1	1				
3	98502-06012	十字螺钉 SCREW, PAN HEAD	2	2				
4	5WG-H1940-30	起动机继电器组合 STARTER RELAY ASSY	1	1				
5	5WG-H1952-10	继电器支架 .HOLDER, RELAY	1	1				
6	5WY-H5540-30	CDI 总成 C.D.I. UNIT ASSY	1	1				
7	1CC-H5700-00	温度传感器 THERMISTOR ASSY	1	1				
8	4S0-H3836-00	卡箍 BAND	1	1				
9	5WY-H2100-10	蓄电池组合 (YTX5L-BS) BATTERY ASSY (YTX5L-BS)	1	1				
10	1CC-H2115-00	正极导线 WIRE, PLUS LEAD	1	1				
11	4KL-H2151-10	保险丝 .FUSE (15A-BL)	2	2				
12	1CC-H2501-20	主开关方向锁组合 MAIN SWITCH STEERING LOCK	1	1				
13	98502-06016	十字螺钉 SCREW, PAN HEAD	2	2				
14	1CC-H2590-00	电缆总成 WIRE HARNESS ASSY	1					
	1CC-H2590-10	电缆总成 WIRE HARNESS ASSY		1				
15	90464-12812	线夹 CLAMP	4	4				
16	90464-20809	线夹 CLAMP	1	1				
17	90465-13152	夹箍 CLAMP	1	1				
18	90464-23811	线夹 CLAMP	1	1				
19	5VL-H3350-21	闪烁继电器组合 FLASHER RELAY ASSY	1	1				
20	5WG-H3371-10	电喇叭 HORN	1	1				
21	98502-06010	十字螺钉 SCREW, PAN HEAD	1	1				

FIG. 34 电气系统 2

ELECTRICAL 2

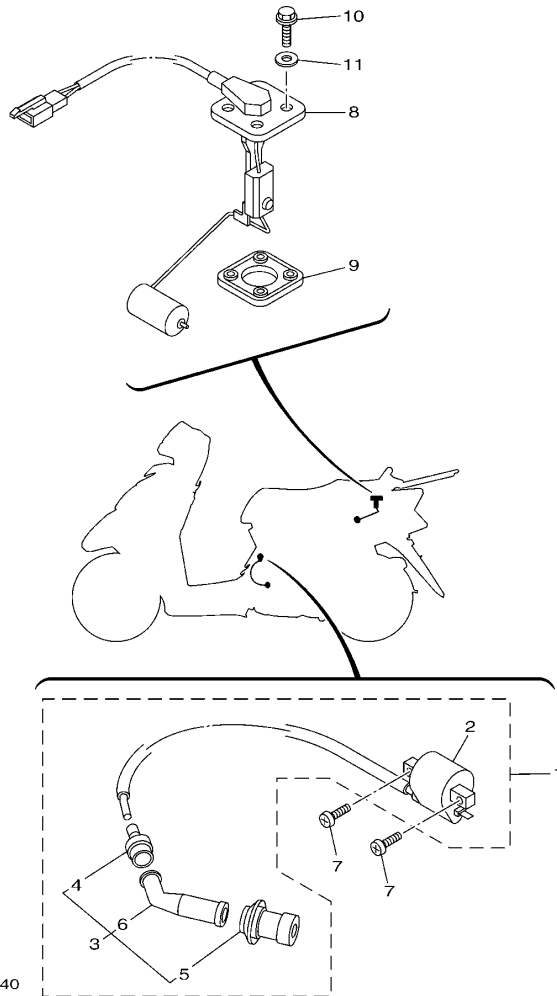

FWD  
1CCB415-M340

参照 号码	零件号码 PART NO.	零件名称 DESCRIPTION	TCCB	TCCC	备注 REMARKS
1	4S0-X8231-30	点火线圈组合 IGN. COIL ASSY.	1	1	
2	4S0-H2310-10	点火线圈组合 IGNITION COIL ASSY	1	1	
3	4S0-H2370-00	火花塞帽组合 PLUG CAP ASSY	1	1	
4	4FP-H2371-00	塞帽 CAP, PLUG	1	1	
5	4KL-H2372-00	塞帽密封 SEAL, PLUG CAP	1	1	
6	4S0-H2373-00	高压绳索密封 SEAL, HIGH TENSION CORD	1	1	
7	98502-06018	十字螺钉 SCREW, PAN HEAD	2	2	
8	4S5-H5752-10	燃油表传感装置组合 SENDER UNIT ASSY, FUEL METER	1	1	
9	4KL-H5753-00	传感器垫圈 GASKET, SENDER UNIT	1	1	
10	90105-05804	凸缘螺栓 BOLT, FLANGE	4	4	
11	90201-053E0	平垫圈 WASHER, PLATE	4	4	

零件号码索引  
NUMERICAL INDEX

零件号码 PART NO.	参照 号码	零件号码 PART NO.	参照 号码	零件号码 PART NO.	参照 号码	零件号码 PART NO.	参照 号码	零件号码 PART NO.	参照 号码	零件号码 PART NO.	参照 号码
1CC-E1111-00	1 - 1	4KL-E3411-01	5 - 10	4S0-E4884-00	8 - 19	1CC-E7620-00	11 - 8	5AP-F3153-00	17 - 5	1CC-F478E-00	19 - 12
1CC-E1111-10	1 - 1	1CC-E3416-00	9 - 13	4S5-E4885-00	8 - 25	1CC-E7623-00	11 - 10	1CC-F4841-10	17 - 19	1CC-F4841-10	19 - 14
1CC-E111F-00	3 - 23	1CC-E3451-00	2 - 3	5WB-E490A-10	7 - 17	1CC-E7632-00	11 - 9	5WG-F3170-00	17 - 8	4KL-F5121-20-35	20 - 8
1CC-E1145-00	3 - 14	1CC-E3451-10	2 - 3	5WB-E490J-30	7 - 2	1CC-E7641-00	11 - 13	1CC-F5135-00	17 - 22	5WG-F5135-00	20 - 9
1CC-E1155-00	1 - 11	5WY-E3475-10	5 - 7	5WB-E490K-10	7 - 3	1CC-E7641-10	11 - 13	4GU-F3173-01	17 - 9	4KL-F5136-00	20 - 12
1CC-E1160-01	1 - 7	4S0-E3542-10	8 - 20	1CC-E4987-00	1 - 25	1CC-E7653-00	11 - 11	1CC-F5138-00	17 - 23	4KL-F5137-21	29 - 8
1CC-E1165-00	1 - 9	1CC-E3556-00	6 - 22	1CC-E5111-00	9 - 1	1CC-E7660-00	11 - 22	4KL-F3191-10	17 - 14	5WG-F5138-00	20 - 10
1CC-E1181-00	1 - 19	1CC-E3569-00	4 - 11	1CC-E5121-00	9 - 2	1CC-E7664-00	11 - 26	4KL-F3192-10	17 - 28	4KL-F513A-01	20 - 19
1CC-E1185-00	1 - 8	1CC-E3575-00	6 - 4	1CC-E5138-00	9 - 3	1CC-E7670-00	11 - 23	1CC-F5151-01	17 - 15	4KL-F5151-01	20 - 18
4KL-E1186-00	1 - 14	1CC-E3585-00	6 - 1	1CC-E5191-00	9 - 26	1CC-E7684-00	11 - 28	1CC-F5155-01	17 - 29	4KL-F5155-01	20 - 20
1CC-E1310-02	1 - 23	1CC-E3595-00	6 - 21	5WG-E5317-01	13 - 3	1CC-F1110-01	13 - 1	1CC-F3317-10	17 - 44	4KL-F5159-00	20 - 22
1CC-E1351-00	1 - 24	5WB-E4105-10	7 - 18	4KL-E5351-10	5 - 9	1CC-F1110-11	13 - 1	1CC-F3340-00	17 - 30	4KL-F5168-30-35	20 - 2
1CC-E1400-00	2 - 1	5WB-E4115-00	7 - 11	4KL-E5363-00	9 - 16	5WG-F1161-01	25 - 23	4RT-F3346-00	17 - 33	5WG-F5181-01	20 - 27
1CC-E1400-10	2 - 1	5WB-E4283-10	7 - 4	1CC-E5363-10	9 - 37	1CC-F116F-00	13 - 14	5LK-F3356-00	17 - 10	5WG-F5315-00	20 - 4
1CC-E1603-00	2 - 9	5WB-E4286-10	7 - 12	5MH-E5371-00	9 - 5	5WG-F118W-00	13 - 7	17 - 24	5WG-F5326-01	21 - 14	
1CC-E1631-00	2 - 6	1CC-E4301-00	7 - 1	1CC-E5373-00	9 - 6	1CC-F1410-00	13 - 10	4FP-F3411-10	17 - 32	4KL-F5338-10-35	21 - 1
1CC-E1633-10	2 - 7	5WB-E4340-00	7 - 14	4S0-E5393-00	9 - 9	5WG-F1481-01	13 - 8	4KL-F3411-10	17 - 38	5WY-F533A-01	21 - 11
1CC-E2111-00	3 - 1	5WB-E4341-20	7 - 7	1CC-E5407-00	9 - 41	5WG-F1482-01	13 - 11	4KL-F3412-20	17 - 35	5WY-F5351-01	21 - 9
1CC-E2113-00	3 - 5	5WB-E4342-16	7 - 6	1CC-E5411-00	9 - 22	1CC-F1552-01	14 - 6	4KL-F3412-30	17 - 37	5WY-F5355-01	21 - 12
1CC-E2116-00	3 - 4	5WB-E4343-52	7 - 8	1CC-E5417-00	9 - 29	5WG-F1553-00	14 - 11	5MH-F3416-01	17 - 40	1CC-F6110-00	22 - 1
1CC-E2117-00	3 - 7	5WB-E4346-00	7 - 21	1CC-E5421-00	9 - 18	5WG-F1557-00	25 - 21	5WG-F3418-01	17 - 43	1CC-F6110-30	22 - 1
1CC-E2118-00	3 - 6	5WB-E4370-10	7 - 20	1CC-E5451-00	9 - 23	1CC-F1587-00	14 - 13	5WG-F341E-00	17 - 36	5WG-F6113-00	22 - 2
1CC-E2119-00	3 - 3	5WB-E4384-10	7 - 15	1CC-E5455-00	9 - 27	1CC-F1611-00	14 - 15	5WG-F341E-10	17 - 39	1CC-F6145-00	22 - 27
1CC-E2121-00	3 - 2	5WB-E4385-10	7 - 19	1CC-E5461-00	9 - 19	1CC-F1685-00	31 - 1	4GU-F3462-00	17 - 31	1CC-F6240-00	22 - 7
1CC-E2151-00	3 - 8	5LB-E4386-00	7 - 10	1CC-E5471-00	9 - 39	1CC-F1690-00	23 - 25	4TU-F3479-00	17 - 11	1CC-F6241-00	22 - 6
1CC-E2156-00	3 - 11	5WB-E4390-00	7 - 9	1CC-E5472-00	9 - 40	1CC-E5481-00	9 - 44	4P7-F6270-01	17 - 25	4P7-F6270-01	22 - 8
5MH-E2157-01	3 - 26	4S0-E4409-00	6 - 15	1CC-E5481-00	9 - 44	1CC-F1711-00	15 - 1	4P7-F3843-00	17 - 34	5WY-F6280-40	22 - 30
1CC-E2159-00	3 - 9	4S0-E4410-03	6 - 5	5WG-E5521-00	10 - 3	4S0-F1753-00	18 - 3	4S5-F4110-10	18 - 1	5WY-F6290-40	22 - 31
1CC-E2170-00	3 - 12	4S0-E4411-02	6 - 7	1CC-E5524-00	10 - 7	5WY-F1753-00	18 - 16	4S0-F4112-00	18 - 4	5WB-F6301-00	22 - 10
1CC-E2170-10	3 - 12	4S0-E4412-01	6 - 6	5MH-E5532-00	10 - 5	4S5-F1773-00	15 - 12	4S0-F4135-00	18 - 22	1CC-F6341-00	22 - 14
1CC-E2176-00	3 - 13	4S0-E4437-00	6 - 11	1CC-E5570-00	10 - 10	5WG-F1823-02	25 - 22	5WG-F414A-00	18 - 15	1CC-F6351-00	22 - 17
5WY-E2210-10	3 - 19	5WY-E443E-01	6 - 14	1CC-E5601-10	10 - 12	4S5-F2210-00	16 - 1	1CC-F4170-00	18 - 24	1CC-F6361-00	24 - 31
5MH-E2213-10	3 - 21	4S0-E443G-00	6 - 16	1CC-E5620-00	10 - 17	4KL-F2216-00	9 - 4	18C-F4180-00	18 - 21	4KL-F637G-01	22 - 18
1CC-E2231-00	3 - 17	1CC-E4445-00	8 - 4	1CC-E5630-10	10 - 19	1CC-F3100-00	17 - 1	4S0-F4311-11	18 - 10	5MH-F637G-01	24 - 41
4KL-E2232-00	3 - 20	4S0-E4451-01	6 - 8	1CC-E5650-00	10 - 1	1CC-F3102-00	17 - 2	4S0-F4312-10	18 - 13	1CC-F6477-00	22 - 24
1CC-E2241-00	3 - 18	4S0-E4453-00	6 - 10	1CC-E5657-00	11 - 16	1CC-F3103-00	17 - 16	1CC-F4313-00	18 - 20	1CC-F7111-10	23 - 1
1CC-E2611-00	4 - 13	5WG-E4476-00	6 - 9	1CC-E5659-00	10 - 21	5WG-F3110-00	17 - 6	4S0-F4314-00	18 - 23	1CC-F7111-10	23 - 1
1CC-E2651-00	4 - 1	5WB-E4504-00	7 - 16	1CC-E5673-00	10 - 20	4KL-F3111-00	17 - 12	1CC-F4315-00	18 - 27	5WG-F7113-01	23 - 4
1CC-E2652-00	4 - 5	5WY-E4610-90	8 - 1	1CC-E6111-10	11 - 1	1CC-E6111-01	11 - 5	5WG-F4500-01	18 - 7	4S0-F4610-01	24 - 4
1CC-E2658-00	4 - 8	4KL-E4613-10	8 - 8	1CC-E6611-01	11 - 5	1CC-F3126-00	17 - 3	4S0-F4610-01	18 - 5	5MH-F7114-00	24 - 39
1CC-E2659-00	4 - 9	1CC-E4651-00	1 - 2	1CC-E6620-10	11 - 20	1CC-F3136-00	17 - 17	5WY-F4633-00	18 - 6	1CC-F7211-00	24 - 25
1CC-E2668-00	4 - 10	1CC-E4718-00	8 - 2	1CC-E6626-10	11 - 21	1CC-F3136-00	17 - 17	1CC-F4726-00	19 - 6	1CC-F7212-00	24 - 27
1CC-E3300-10	5 - 1	4KL-E4737-00	8 - 7	1CC-E7211-10	12 - 7	5WG-F3141-00	17 - 7	1CC-F4727-00	19 - 7	1CC-F7263-00	24 - 28
1CC-E3324-00	2 - 4	5WB-E4803-11	8 - 17	1CC-E7410-10	12 - 1	4GU-F3145-00	17 - 21	1CC-F4730-00	19 - 1	1CC-F7285-00	24 - 26
1CC-E3324-10	2 - 4	5WG-E4806-01	8 - 22	1CC-E7421-10	12 - 6	5AP-F3147-00	17 - 13	1CC-F473R-00	19 - 5	4S5-F7311-10	23 - 15
1CC-E3325-10	5 - 2	5WG-E4815-00	8 - 13	1CC-E7601-00	11 - 7	17 - 18	17 - 18	5WY-F4742-00	19 - 8	1CC-F7311-10	24 - 15
1CC-E3362-00	5 - 3	5WY-E4872-30	8 - 12	1CC-E7602-10	11 - 19	17 - 13	17 - 13	1CC-F475M-00	19 - 2	4KL-F7314-00	23 - 2
1CC-E3363-00	5 - 4	4S0-E4883-00	8 - 15	1CC-E7611-00	11 - 14	17 - 27	17 - 27	4S5-F4780-01	19 - 10	24 - 2	24 - 2

零件号码索引  
NUMERICAL INDEX

零件号码 PART NO.	参照 号码	零件号码 PART NO.	参照 号码	零件号码 PART NO.	参照 号码	零件号码 PART NO.	参照 号码	零件号码 PART NO.	参照 号码	零件号码 PART NO.	参照 号码
1CC-F7481-00	23 - 7	1CC-H2129-00	24 - 10	4KL-H5753-00	34 - 9	90119-08864	19 - 15	90214-14804	11 - 15	90467-12802	9 - 7
	24 - 7	4KL-H2151-10	33 - 11	1CC-X1543-01	9 - 43	90149-06108	18 - 8	90240-06804	24 - 32		18 - 2
1CC-F7482-00-P2	23 - 19	450-H2310-10	34 - 2	1CC-X2142-00	13 - 2	90153-06803	1 - 3	90249-12806	22 - 16	90467-13804	1 - 26
	24 - 19	450-H2370-00	34 - 3	1CC-X2150-00-P2	14 - 1	90154-06004	24 - 37		22 - 21	90467-13815	6 - 17
1CC-F7482-00-P3	23 - 19	4FP-H2371-00	34 - 4	1CC-X2150-00-P3	14 - 1	90157-05029	24 - 36	90269-06809	15 - 2	90467-16805	8 - 16
	24 - 19	4KL-H2372-00	34 - 5	1CC-X2150-00-P4	14 - 1	90157-05812	32 - 2		15 - 4	90467-16808	8 - 26
1CC-F7482-00-P4	23 - 19	450-H2373-00	34 - 6	1CC-X2150-00-P5	14 - 1		32 - 9		15 - 7	90480-12803	14 - 16
	24 - 19	1CC-H2501-20	33 - 12	1CC-X2150-00-UG	14 - 1	90170-05801	3 - 10		23 - 13	90480-13398	30 - 8
1CC-F7482-00-P5	23 - 19	1CC-H252H-00	23 - 8	1CC-X2172-30-P2	15 - 3	90170-06020	24 - 38		23 - 21	90480-30800	4 - 4
	24 - 19		24 - 8	1CC-X2172-30-P3	15 - 3	90170-12181	26 - 5		23 - 24	90501-16829	5 - 11
1CC-F7482-00-UG	23 - 19	5MH-H2566-11	24 - 35	1CC-X2172-30-P4	15 - 3	90170-28802	11 - 29		24 - 13	90501-16831	22 - 20
	24 - 19	1CC-H2590-00	33 - 14	1CC-X2172-30-P5	15 - 3	90176-08811	1 - 17		24 - 21	90501-43804	11 - 27
1CC-F7483-00	23 - 14	1CC-H2590-10	33 - 14	1CC-X2172-30-UG	15 - 3	90179-06843	22 - 15		24 - 24	90506-12001	20 - 16
1CC-F7483-10	24 - 14	1CC-H3310-00	28 - 1	1CC-X2173-30-P2	15 - 6		22 - 22		31 - 3		21 - 7
1CC-F7492-00-P2	23 - 22	1CC-H3311-10	28 - 2	1CC-X2173-30-P3	15 - 6	90179-06850	8 - 9	90269-09800	14 - 4	90506-14803	24 - 30
	24 - 22		28 - 6	1CC-X2173-30-P4	15 - 6	90179-10817	11 - 6	90280-03045	2 - 5	90506-15001	20 - 17
1CC-F7492-00-P3	23 - 22		31 - 9	1CC-X2173-30-P5	15 - 6	90179-25810	17 - 41	90340-12806	9 - 45		21 - 8
	24 - 22	1CC-H331E-00	28 - 3	1CC-X2173-30-UG	15 - 6	90183-05807	25 - 17	90380-15806	10 - 14	90506-20816	23 - 18
1CC-F7492-00-P4	23 - 22	1CC-H3320-00	28 - 5	1CC-X2473-00	19 - 4	90183-05818	14 - 5	90387-06160	30 - 7		24 - 18
	24 - 22	1CC-H332E-00	28 - 7	5WG-X2534-00	20 - 15		14 - 8	90387-068F6	8 - 3	90506-35820	23 - 6
1CC-F7492-00-P5	23 - 22	5VL-H3350-21	33 - 19		21 - 6		15 - 5	90387-068H6	15 - 11		24 - 6
	24 - 22	5WG-H3371-10	33 - 20	1CC-X2610-30-P0	22 - 23		15 - 8	90387-068J2	8 - 23	90508-26801	20 - 21
1CC-F7492-00-UG	23 - 22	1CC-H3509-00	29 - 5	1CC-X2610-30-P3	22 - 23		22 - 26		18 - 26	90508-32804	10 - 13
	24 - 22	1CC-H3510-20	29 - 1	1CC-X2610-30-P4	22 - 23		23 - 12	90387-068K5	4 - 2	90520-05807	25 - 18
1CC-F8257-00	25 - 6	1CC-H3517-00	29 - 3	1CC-X2610-30-P5	22 - 23		24 - 12	90387-12853	26 - 4	90560-12138	20 - 3
1CC-F8312-00	25 - 1	1CC-H3517-10	29 - 2	1CC-X2610-30-UG	22 - 23		25 - 27	90387-128M1	20 - 26	91312-06012	3 - 24
1CC-F8312-10	25 - 1	1CC-H353K-00	29 - 4	4S0-X8231-30	34 - 1	90183-05819	25 - 3	90387-16806	10 - 11	91312-06016	3 - 22
1CC-F8313-00	25 - 10	1CC-H3550-00	29 - 7	90101-06046	20 - 23	90185-14807	21 - 4	90387-16816	11 - 12	91312-06020	27 - 9
1CC-F833B-00	25 - 16	450-H3836-00	33 - 8		21 - 13	90201-053E0	34 - 11	90413-12800	9 - 8	91312-06025	10 - 18
1CC-F8345-00-P0	25 - 26	5WY-H3912-20	32 - 1	90101-10809	16 - 3	90201-06814	8 - 5	90430-06014	1 - 4	91312-06090	1 - 22
	25 - 25	5WG-H3922-01	32 - 8	90105-05804	34 - 10		25 - 8		9 - 30	91402-20012	24 - 33
1CC-F8365-00	25 - 11	450-H3963-01	32 - 4	90105-08861	16 - 2	90201-07076	20 - 11	90430-08119	9 - 15	91808-12804	9 - 35
	25 - 15	450-H3975-01	32 - 5	90105-10839	22 - 3	90201-07811	5 - 5	90450-45801	6 - 19	91810-14805	1 - 20
1CC-F837F-00	25 - 19	1CC-H3980-10	32 - 6	90109-06822	19 - 9	90201-08827	1 - 16	90464-08020	4 - 12		1 - 21
1CC-F8388-00	25 - 14	1CC-H4310-00	30 - 1		25 - 2	90201-108A3	10 - 4	90464-12812	33 - 15		9 - 10
1CC-F83N0-00	25 - 9	1CC-H4312-00	30 - 4		31 - 2	90201-12172	9 - 46	90464-20809	22 - 13		9 - 20
5WY-H1410-11	26 - 2	45S-H4314-00	30 - 2	90109-08836	23 - 16	90201-15803	12 - 4		33 - 16		9 - 24
5WY-H1450-01	26 - 1	1CC-H4347-00	30 - 3		24 - 16	90201-15838	10 - 15	90464-23811	33 - 18	91A11-07048	18 - 17
1CC-H1800-01	27 - 1	1CC-H4540-10	31 - 11	90113-06804	1 - 5	90201-17804	13 - 5	90465-12803	4 - 6	92012-05010	22 - 12
4RT-H1801-00	27 - 6	1CC-H4700-10	31 - 7	90116-06820	1 - 6	90201-20819	21 - 5	90465-13152	33 - 17	92902-06200	24 - 34
5WV-H1828-01	27 - 3	4KL-H4714-20	31 - 8	90116-08811	1 - 27	90202-05193	18 - 9	90467-08003	18 - 14	93102-17808	11 - 3
1CC-H183G-00	27 - 2	1CC-H4743-00	31 - 10	90119-05827	14 - 10	90202-15804	23 - 3		18 - 28	93102-17853	20 - 5
5WG-H1940-30	33 - 4	1CC-H5130-00	31 - 6	90119-06157	14 - 12		24 - 3	90467-08070	8 - 21	93102-19805	9 - 31
5WG-H1952-10	33 - 5	4KL-H5131-20	31 - 4		23 - 9	90202-26142	17 - 42	90467-09006	18 - 11	93102-19810	9 - 32
5WY-H1960-10	33 - 2	5WY-H5540-30	33 - 6		23 - 26	90202-26801	27 - 8		18 - 19	93102-22811	9 - 12
5WY-H2100-10	33 - 9	450-H5546-00	33 - 1		24 - 9	90208-12050	11 - 17	90467-10008	18 - 12	93102-26852	12 - 11
1CC-H2115-00	33 - 10	1CC-H5700-00	33 - 7		24 - 44	90208-15801	12 - 5	90467-12802	6 - 13	93104-07803	20 - 13
1CC-H2129-00	23 - 10	45S-H5752-10	34 - 8	90119-068A3	14 - 7	90208-21802	12 - 8		6 - 18	93106-47814	20 - 14



零件号码索引  
NUMERICAL INDEX

零件号码 PART NO.	参照 号码	零件号码 PART NO.	参照 号码	零件号码 PART NO.	参照 号码	零件号码 PART NO.	参照 号码	零件号码 PART NO.	参照 号码	零件号码 PART NO.	参照 号码
93109-33803	11 - 24	95602-08200	24 - 17	97702-50016	14 - 9						
93210-07809	9 - 34	95602-10200	13 - 9		22 - 5						
93210-07890	21 - 16		13 - 12		22 - 25						
93210-09859	21 - 10		22 - 4		25 - 4						
93210-14104	29 - 9	95602-12200	20 - 28		25 - 7						
93210-14815	9 - 17	95702-06500	6 - 3		28 - 4						
93210-15171	3 - 25		8 - 14		28 - 8						
93210-15639	13 - 4		8 - 24		29 - 6						
93210-23614	27 - 4		18 - 25		31 - 12						
93210-25806	6 - 2		19 - 3	97702-60016	14 - 14						
93210-26812	9 - 38	95702-10500	16 - 4	97702-60020	30 - 5						
93210-34803	5 - 12		21 - 15	97702-60530	4 - 7						
93210-36800	11 - 25	95802-06010	19 - 11	98501-04008	7 - 5						
93210-44678	27 - 5		24 - 42	98502-03008	32 - 7						
93210-44808	1 - 15	95802-06012	8 - 18	98502-05010	22 - 11						
93210-62802	1 - 12		17 - 45	98502-05012	19 - 13						
93211-02802	9 - 33		25 - 24	98502-05020	22 - 9						
93306-003YK	10 - 8	95802-06014	13 - 15	98502-06010	33 - 21						
93306-200X0	11 - 4		18 - 18	98502-06012	10 - 6						
	12 - 3	95802-06020	30 - 6		22 - 19						
93306-201YA	20 - 7	95802-10014	24 - 40		33 - 3						
93306-204XC	12 - 10	95812-08016	3 - 15	98502-06016	26 - 3						
93306-205XY	2 - 2		9 - 14		33 - 13						
93306-253Y0	11 - 2	95812-08030	8 - 11	98502-06018	34 - 7						
	12 - 12	95812-08050	8 - 10	98502-06020	4 - 3						
93306-301XV	20 - 6	95812-10030	13 - 13	98702-06020	5 - 8						
93311-315X0	12 - 2	95812-10035	23 - 5	98902-05008	27 - 7						
93317-110Y4	10 - 2		24 - 5	98902-06010	9 - 28						
93410-20823	12 - 9	97522-06512	1 - 10	98902-06020	9 - 42						
93450-15825	2 - 8	97601-04014	7 - 13		15 - 10						
93603-70800	25 - 13	97602-05216	22 - 29	98980-06020	8 - 6						
93900-00827	20 - 25	97602-06214	4 - 14	99001-05600	5 - 6						
93900-00827	21 - 2	97602-06220	6 - 12	99002-09600	24 - 29						
94110-10810	20 - 1	97602-06225	6 - 20	99009-15400	10 - 16						
94110-10811	21 - 3		26 - 6	99009-17400	13 - 6						
94568-A2084	3 - 16	97702-40512	25 - 20	99009-35700	10 - 9						
94700-00869	1 - 18	97702-50010	25 - 12								
95022-06020	1 - 13	97702-50012	14 - 2								
	9 - 36		15 - 9								
95022-06030	9 - 21		22 - 28								
95022-06035	9 - 25		23 - 11								
95022-06070	9 - 11		23 - 20								
95302-06600	20 - 24		23 - 23								
95302-12700	11 - 18		24 - 11								
95602-05100	32 - 3		24 - 20								
	32 - 10		24 - 23								
95602-05200	31 - 5		25 - 5								
95602-08200	23 - 17	97702-50016	14 - 3								



# 雅马哈纯正机油大集结



## 纯正机油

### 品质保证! 动力之源!

### 请经销YAMALUBE纯正 机油!



90793-AC421-T1  
90793-AC421-G1  
SAE 10W-40 (1L)  
高等级/通用



90793-AC432-00  
SAE 10W-30 (1L)  
通用机油



90793-AC423-T1  
90793-AC423-G1  
SAE 20W-40 (1L)  
跨骑车专用



90793-AC427-T1  
90793-AC427-G1  
SAE 10W-40 (0.8L)  
弯梁车专用



90793-AC426-T1  
SAE 5W-30 (1L)  
冬季专用/通用



90793-AC434-00  
SAE 10W-30 (0.8L)  
弯梁车专用



90793-AC425-T1  
90793-AC425-G1  
SAE 20W-40 (1L)  
踏板车专用



90793-AC404  
GEAR (0.13L)  
齿轮油  
踏板车专用

友情提示：磨合期后，建议每1500KM更换一次机油(可根据实际使用状况减少里程数)。并清洗机油滤网。