

零件目录

PARTS CATALOGUE

LCK125 (BK91) P.R. OF CHINA

LCK125 (BK92) P.R. OF CHINA

前言

本零件目录记载着封面页所示型号所使用的零件。当您订购更换零件时，请参阅本零件目录并正确指示零件号码和零件名称。

1. 零件目录发行后有变更或附加零件时，将会以雅马哈零件信息通知大家。
建议您应按照雅马哈零件信息修改本零件目录。

2. 省略记号

本文中所记载的省略记号的意思如下。

“UR” 需要指定的零件号码。

“UN” 需要数。

“AP” 选购品

“LM” 当地制造（必需于当地订购的零件）

“F#” 车架号（适用的机器号）

“O/S” 超过尺寸

3. 组件中部件的数量

- 组件的销售零件，如下所示，在零件名称的前面加上（.）的记号来表示。
- 每个部件右侧的数字表示各组件单体内该部件的数量。

零件号码	零件名称	数量	备注
2F5 - 83310 - 60	前闪光灯组合	2	
115 - 83311 - 60	. 灯泡 (6V - 18W)	1	

4. 适用的图形颜色表示在“备注”中，如下所示。

零件号码	零件名称	数量	备注
2N4 - 24110 - 00 - X5	燃油箱组件	2	MXR
3J1 - 24240 - 10	. 燃油箱图形	1	适用于MXR

5. 请注意插图只用于找寻零件号码时参照，并不适用于组装。组装时，请使用适用的维修手册。

6. 在参照号码前的星号（*）表示其为在第一版后更改的项目。

前言

7. 适用的系列号码

车架系列号

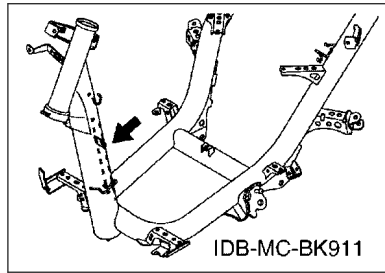

发动机系列号码

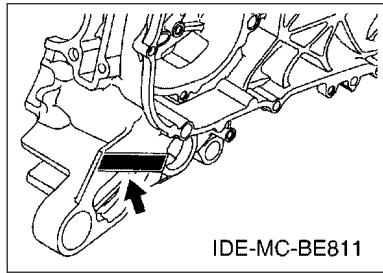

8. 适用的颜色记号 (*标志表示型号颜色。)

省略记号	颜色名称 (英文)	颜色名称	颜色记号
DNPM1	DARK GRAYISH PURPLE METALLIC 1	浅紫灰黑色	0740
IPB(*)	IMPERIAL BROWN	棕色	00UG
MBL2(*)	MAT BLACK 2	无光泽黑	0582
MDNM1	MAT DARK GRAY METALLIC 1	无光泽金属暗灰1	1113
MS1(*)	MAT SILVER 1	无光泽银	1160
NG	NEBURA GOLD	金色	008L
RM7(*)	RED METALLIC 7	金属红色7	1218
SL	SILVER	银色	0035
SMX(*)	BLACK METALLIC X	金属黑色	0903
VPBM9(*)	VIVID PURPLISH BLUE METALLIC 9	金属蓝紫色	1613
WM6(*)	WHITE METALLIC 6	金属白6	1124

9. 适用的初始系列号码

车架系列号

系列号码	数量栏名称	型号记号

发动机系列号码

系列号码	数量栏名称	型号记号

型号信息

10. 颜色信息

型号代码	颜色类型代码	颜色记号	颜色名称 (英文)	颜色名称	省略记号
BK91	A	1160	MAT SILVER 1	无光泽银	MS1
	B	1613	VIVID PURPLISH BLUE METALLIC 9	金属蓝紫色	VPBM9
	C	0903	BLACK METALLIC X	金属黑色	SMX
	D	1218	RED METALLIC 7	金属红色7	RM7
	E	00UG	IMPERIAL BROWN	棕色	IPB
	F	1124	WHITE METALLIC 6	金属白6	WM6
	G	0582	MAT BLACK 2	无光泽黑	MBL2
	H	0903	BLACK METALLIC X	金属黑色	SMX
	J	1218	RED METALLIC 7	金属红色7	RM7
BK92	A	1160	MAT SILVER 1	无光泽银	MS1
	B	1613	VIVID PURPLISH BLUE METALLIC 9	金属蓝紫色	VPBM9
	C	0903	BLACK METALLIC X	金属黑色	SMX
	D	1218	RED METALLIC 7	金属红色7	RM7
	E	00UG	IMPERIAL BROWN	棕色	IPB
	F	0903	BLACK METALLIC X	金属黑色	SMX
	G	1218	RED METALLIC 7	金属红色7	RM7

目录

发动机

气缸.....	1
曲柄·活塞.....	2
阀门.....	3
凸轮轴·链条.....	4
油泵.....	5
空气罩&风扇.....	6
进气门.....	7
排气装置.....	9
曲轴箱.....	10
曲轴箱盖1.....	12
起动机.....	13
离合器.....	14
传动.....	16

车体

车架.....	17
挡泥板.....	18
侧盖.....	19
后悬挂.....	20
操纵系统.....	21
操纵系统2.....	22
前叉(碟刹).....	23
前叉(鼓刹).....	25
油箱.....	27
座位.....	28
前轮(碟刹).....	29
前轮(鼓刹).....	30
前制动器卡钳.....	31
后轮.....	32
操纵手柄·钢索(碟刹).....	33
操纵手柄·钢索(鼓刹).....	35
前主缸.....	37
搁脚·支架.....	38
护腿.....	40
发电机.....	41
起动机.....	42
转向灯.....	43
仪表.....	44
前大灯.....	45

尾灯.....	46
手柄开关(碟刹).....	47
手柄开关(鼓刹).....	48
电气系统1.....	49
电气系统2.....	50

索引

零件号码索引.....	51
-------------	----

CONTENTS

ENGINE

CYLINDER.....	1
CRANKSHAFT & PISTON.....	2
VALVE.....	3
CAMSHAFT & CHAIN.....	4
OIL PUMP.....	5
AIR SHROUD & FAN.....	6
INTAKE.....	7
EXHAUST.....	9
CRANKCASE.....	10
CRANKCASE COVER 1.....	12
STARTER.....	13
CLUTCH.....	14
TRANSMISSION.....	16

CHASSIS

FRAME.....	17
FENDER.....	18
SIDE COVER.....	19
REAR SUSPENSION.....	20
STEERING.....	21
STEERING 2.....	22
FRONT FORK FOR DISK BRAKE.....	23
FRONT FORK FOR DRUM BRAKE.....	25
FUEL TANK.....	27
SEAT.....	28
FRONT WHEEL FOR DISK BRAKE.....	29
FRONT WHEEL FOR DRUM BRAKE.....	30
FRONT BRAKE CALIPER.....	31
REAR WHEEL.....	32
STEERING CABLE FOR DISK BRAKE.....	33
STEERING CABLE FOR DRUM BRAKE.....	35
FRONT MASTER CYLINDER.....	37
STAND & FOOTREST.....	38
LEG SHIELD.....	40
GENERATOR.....	41
STARTING MOTOR.....	42
FLASHER LIGHT.....	43
METER.....	44
HEADLIGHT.....	45

TAILLIGHT.....	46
SWITCH & LEVER FOR DISK BRAKE.....	47
SWITCH & LEVER FOR DRUM BRAKE.....	48
ELECTRICAL 1.....	49
ELECTRICAL 2.....	50

INDEX

NUMERICAL INDEX.....	51
----------------------	----

FIG. 1 气缸

CYLINDER

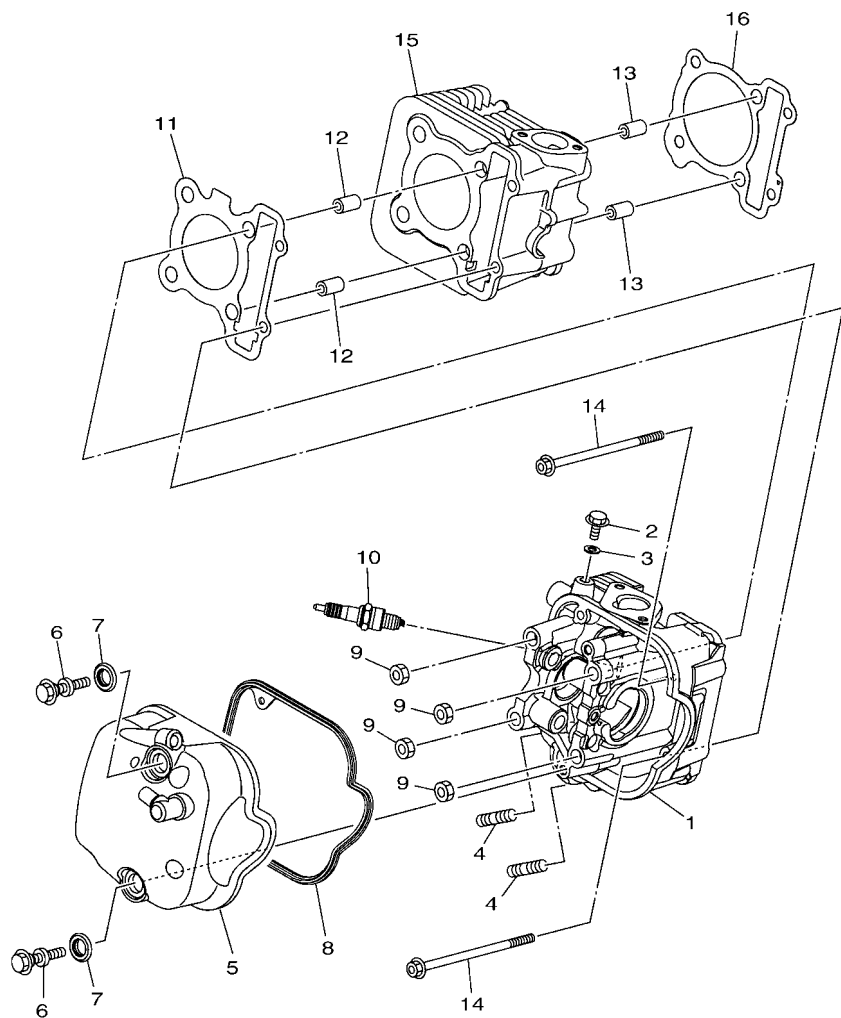

BE81415-S010

参照 号码	零件号码 PART NO.	零件名称 DESCRIPTION	BK91	BK92	备注 REMARKS
1	BE8-E1111-00	气缸头1 HEAD, CYLINDER 1	1	1	
2	95022-06010	凸缘螺栓 BOLT, FLANGE	1	1	
3	90430-06014	衬垫 GASKET	1	1	
4	95612-08618	双头螺栓 BOLT, STUD	2	2	
5	BE8-E1190-00	气缸头盖1 COVER, CYLINDER HEAD 1	1	1	
6	BE8-E119E-00	气缸盖罩螺 BOLT, COVER HEAD	2	2	
7	BE8-E111G-00	橡皮支座1 RUBBER, MOUNT 1	2	2	
8	BE8-E1193-00	气缸盖罩衬垫1 GASKET, HEAD COVER 1	1	1	
9	95302-08600	螺母 NUT, HEXAGON	4	4	
10	94700-00869	火花塞 (NGK CR6HSA) PLUG SPARK (NGK CR6HSA)	1	1	
11	2TS-E1181-00	气缸头垫片1 GASKET, CYLINDER HEAD 1	1	1	
12	99530-10114	定位销 PIN, DOWEL	2	2	
13	99530-10114	定位销 PIN, DOWEL	2	2	
14	90110-06868	六角头插座螺栓 BOLT, HEXAGON SOCKET HEAD	2	2	
15	BE8-E1311-00	气缸1 CYLINDER 1	1	1	
16	BE8-E1351-00	气缸衬垫 GASKET, CYLINDER	1	1	

FIG. 2 曲柄·活塞

CRANKSHAFT & PISTON

参照 号码	零件号码 PART NO.	零件名称 DESCRIPTION	BK91	BK92	备注 REMARKS
1	BE8-X1400-00	曲轴组合 CRANKSHAFT ASSY	1	1	
2	93306-372X7	轴承 BEARING	1	1	
3	BE8-E3324-00	机油泵驱动齿轮 GEAR, PUMP DRIVE	1	1	
4	90280-03045	半圆键 KEY, WOODRUFF	1	1	
5	2BM-E1631-10	活塞 (STD) PISTON (STD)	1	1	
6	BE8-E1633-00	活塞销 PIN, PISTON	1	1	
7	93450-14088	卡环 CIRCLIP	2	2	
8	BE8-X1161-10	活塞环套件 (STD) PISTON RING SET (STD)	1	1	

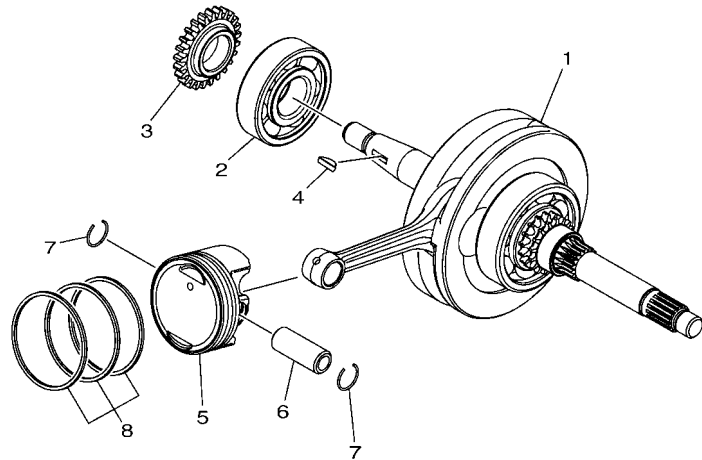

BE81415-S020

FIG. 3 阀门

VALVE

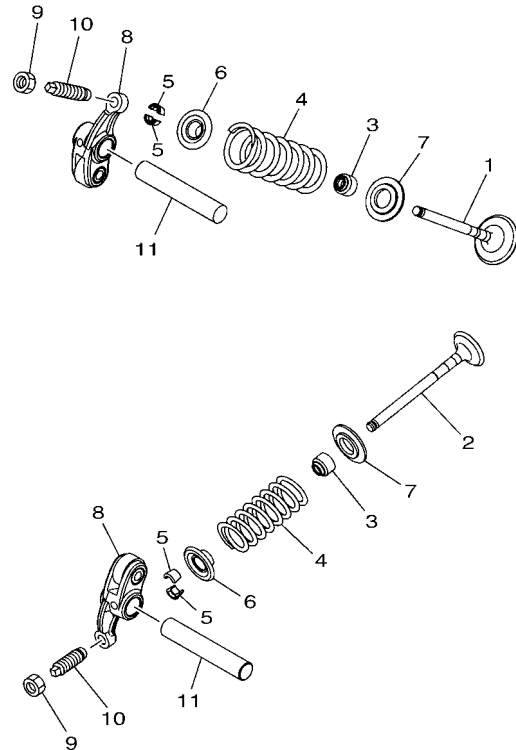

参照 号码	零件号码 PART NO.	零件名称 DESCRIPTION	BK91	BK92	备注 REMARKS
1	BE8-E2111-00	进气门 VALVE, INTAKE	1	1	
2	BE8-E2121-00	排气门 VALVE, EXHAUST	1	1	
3	1DB-E2119-00	气门油封 SEAL, VALVE STEM	2	2	
4	BE8-E2113-00	气门内弹簧 SPRING, VALVE INNER	2	2	
5	4S5-E2118-00	气门锁夹 LOCK, VALVE SPRING RETAINER	4	4	
6	BE8-E2117-00	气门弹簧座 RETAINER, VALVE SPRING	2	2	
7	BE8-E2126-00	气门弹簧座2 SEAT, VALVE SPRING 2	2	2	
8	BE8-E2151-00	气门摇臂 ARM, VALVE ROCKER	2	2	
9	90170-05302	螺母 NUT	2	2	
10	BE8-E2159-00	气门调整螺钉 SCREW, VALVE ADJUSTING	2	2	
11	BE8-E2146-00	摇臂轴 SHAFT, ROCKER	2	2	



2BM1422-P030

FIG. 4 凸轮轴·链条

CAMSHAFT & CHAIN

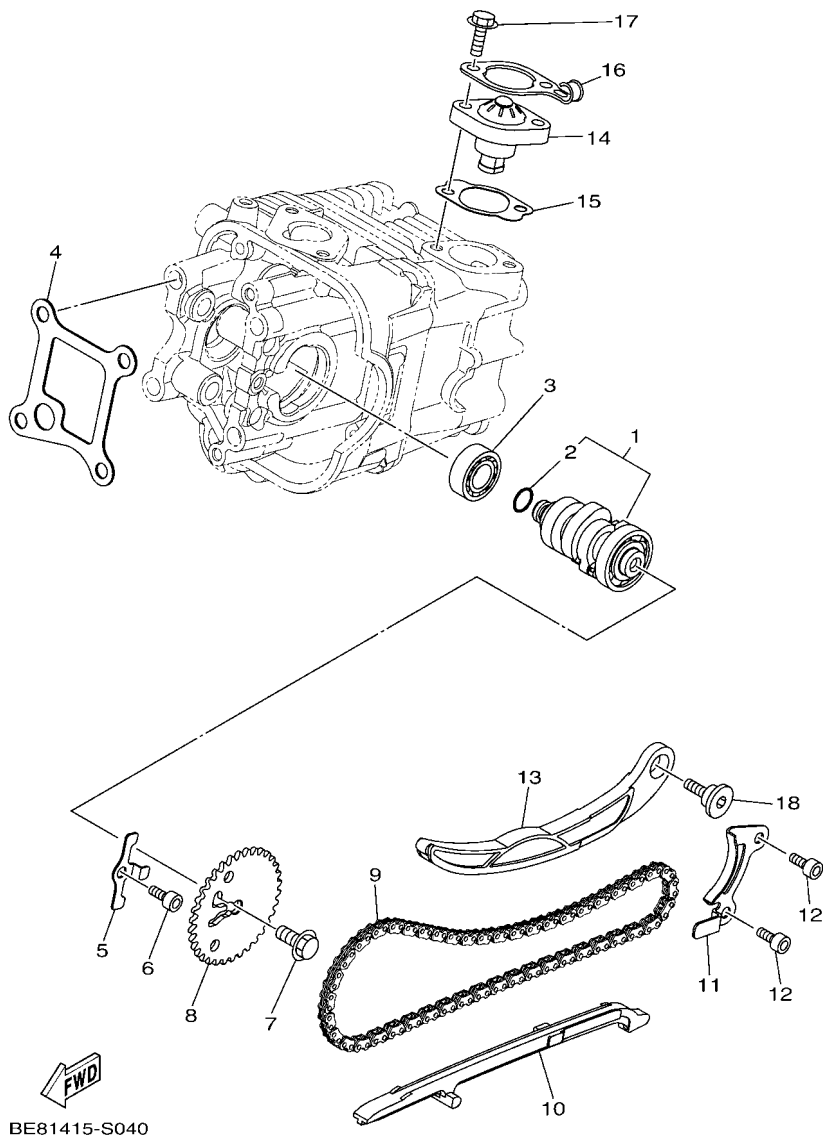

参照 号码	零件号码 PART NO.	零件名称 DESCRIPTION	BK91	BK92	备注 REMARKS
1	BE8-X1217-00	凸轮轴总成 CAMSHAFT ASSY 1	1	1	
2	93210-09859	.O型环 .O-RING	1	1	
3	93306-001YG	轴承 BEARING	1	1	
4	BE8-E111F-00	面板 PLATE	1	1	
5	BE8-E112F-00	面板2 PLATE 2	1	1	
6	91312-06012	螺栓 BOLT	1	1	
7	90105-07801	凸缘螺栓 BOLT, FLANGE	1	1	
8	BE8-E2176-00	链轮 SPROCKET, CAM CHAIN	1	1	
9	94568-J7092	链条 CHAIN	1	1	
10	BE8-E2231-00	导向限位板1 GUIDE, STOPPER 1	1	1	
11	BE8-E2233-00	导向限位板面板1 PLATE, GUIDE STOPPER 1	1	1	
12	91312-06012	螺栓 BOLT	2	2	
13	BE8-E2241-00	导向限位板2 GUIDE, STOPPER 2	1	1	
14	2BM-E2210-00	链条张紧器组合 TENSIONER ASSY, CAM CHAIN	1	1	
15	BE8-E2213-00	张紧器垫片 GASKET, TENSIONER CASE	1	1	
16	BE8-E5118-00	支架 HOLDER	1	1	
17	95022-06020	凸缘螺栓 BOLT, FLANGE	2	2	
18	BE8-E2228-00	螺栓 BOLT	1	1	

FIG. 6 空气罩&风扇

AIR SHROUD & FAN

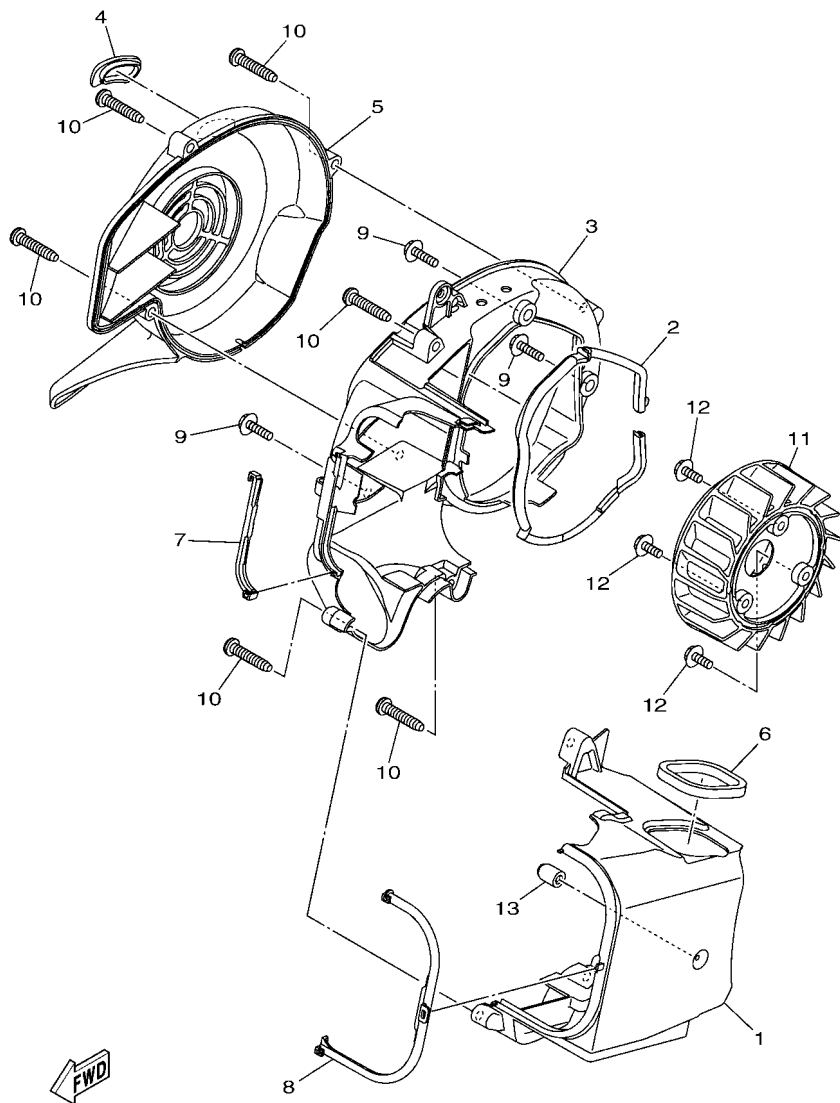

BE81415-S060

参照 号码	零件号码 PART NO.	零件名称 DESCRIPTION	BK91	BK92	备注 REMARKS
1	BE8-E2651-00	气缸空气罩1 AIR SHROUD, CYLINDER 1	1	1	
2	BE8-E2658-00	冷却风道避震垫1 DAMPER, AIR SHROUD 1	1	1	
3	BE8-E2652-00	气缸空气罩2 AIR SHROUD, CYLINDER 2	1	1	
4	BE8-E261C-00	橡胶圈 GROMMET SHROUD 2	1	1	
5	BE8-E2653-00	气缸空气罩3 AIR SHROUD, CYLINDER 3	1	1	
6	90520-05819	面板减震器 DAMPER, PLATE	1	1	
7	BE8-E2659-00	冷却风道避震垫2 DAMPER, AIR SHROUD 2	1	1	
8	BE8-E2668-00	冷却风道避震垫3 DAMPER, AIR SHROUD 3	1	1	
9	95822-06020	凸缘螺栓 BOLT, FLANGE	3	3	
10	97702-60530	自攻螺钉 SCREW, TAPPING	6	6	
11	BE8-E2611-00	风扇 FAN	1	1	
12	95812-06016	凸缘螺栓 BOLT, FLANGE	3	3	
13	BE8-E3569-00	绝缘插头 PLUG, BLIND	1	1	

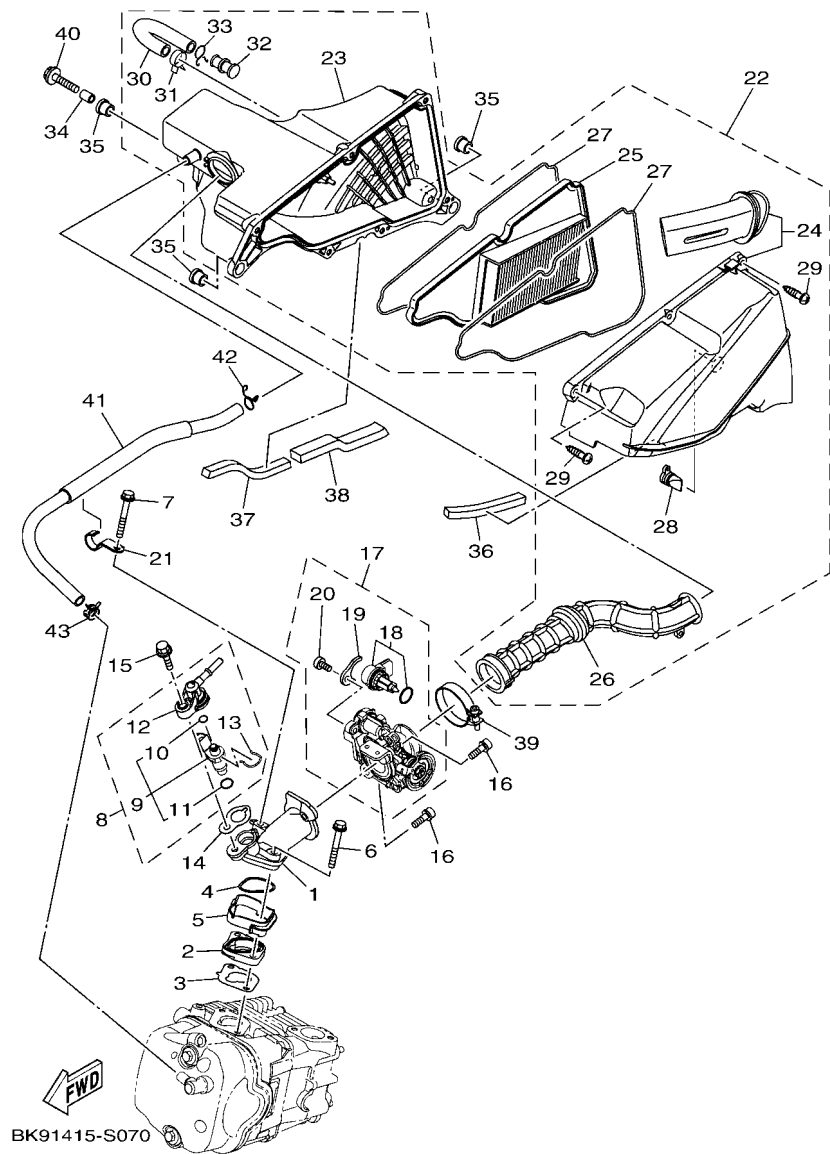

FIG. 7 进气门

INTAKE

参照 号码	零件号码 PART NO.	零件名称 DESCRIPTION	BK91	BK92	备注 REMARKS
1	BE8-E3585-00	岐管 MANIFOLD	1	1	
2	BE8-E3595-00	接头 JOINT	1	1	
3	BE8-E3556-00	岐管衬垫 GASKET, MANIFOLD	1	1	
4	93210-35895	O型环 O-RING	1	1	
5	BE8-E3593-00	风 DAMPER	1	1	
6	95812-06035	凸缘螺栓 BOLT, FLANGE	1	1	
7	95812-06045	凸缘螺栓 BOLT, FLANGE	1	1	
8	2PH-E3770-00	喷射器总成 INJECTOR ASSY	1	1	
9	2PH-E3761-00	喷射器组合 INJECTOR ASSY	1	1	
10	54P-E4147-00	O型环 O-RING	1	1	
11	5CA-E4147-00	O型环 O-RING	1	1	
12	54P-E3938-00	管 PIPE	1	1	
13	54P-E4137-00	钢夹 CLIP	1	1	
14	BE8-E3557-00	衬垫 GASKET	1	1	
15	95812-06025	凸缘螺栓 BOLT, FLANGE	1	1	
16	90110-06846	六角头插座螺栓 BOLT, HEXAGON SOCKET HEAD	2	2	
17	BE8-E3750-00	节气门本体组合 THROTTLE BODY ASSY	1	1	
18	2TD-H5801-00	步进电机 STEPPING MOTOR	1	1	
19	54P-E4243-00	面板 PLATE	1	1	
20	98502-06012	十字螺钉 SCREW, PAN HEAD	1	1	
21	BE8-E4146-00	面板 PLATE	1	1	
22	BE8-E4410-00	空气净化器组合 AIR CLEANER ASSY.	1	1	
23	BE8-E4411-00	空气净化器箱1 CASE, AIR CLEANER 1	1	1	
24	BE8-WE412-00	空气净化器箱盖1 CAP, CLEANER CASE 1	1	1	
25	BE8-E4450-00	空气净化器滤芯组合 ELEMENT ASSY, AIR CLEANER	1	1	
26	BE8-E4453-00	空气净化器接头1 JOINT, AIR CLEANER 1	1	1	
27	BE8-E4452-00	密封垫 SEAL	2	2	

FIG. 7 进气门

INTAKE

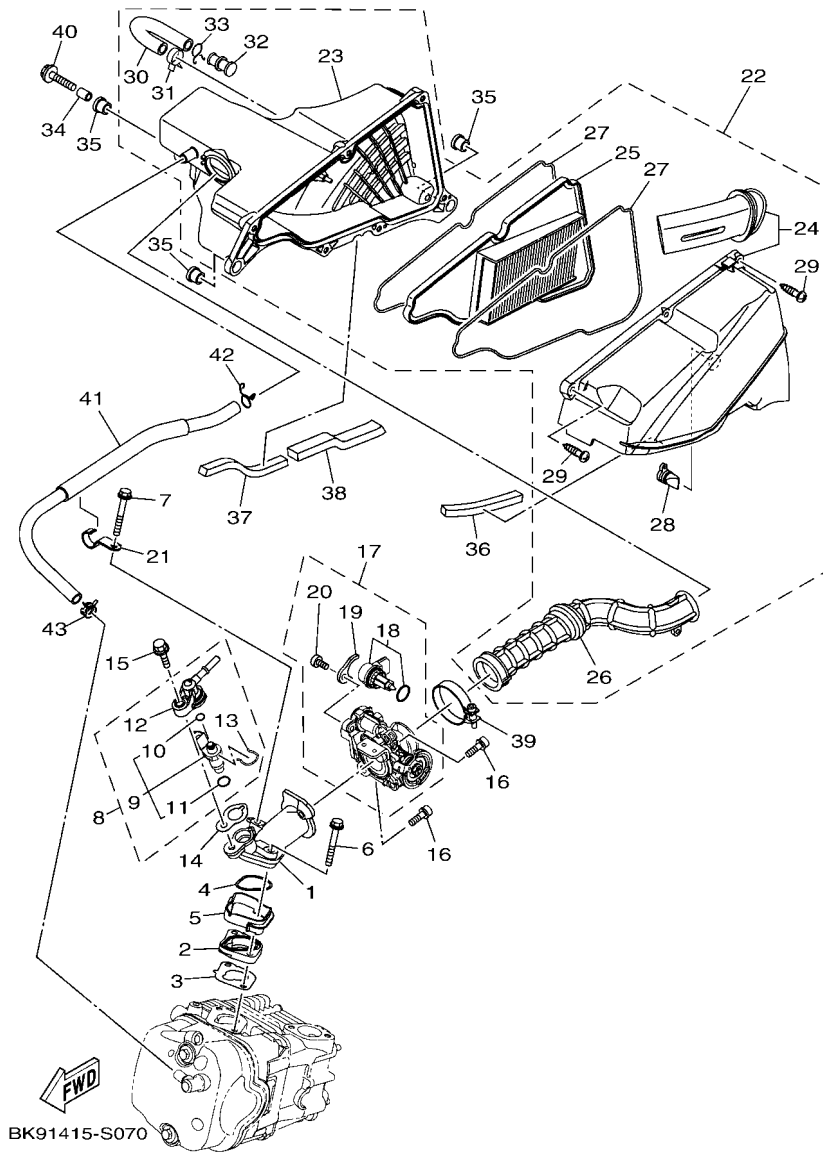

参照 号码	零件号码 PART NO.	零件名称 DESCRIPTION	BK91	BK92	备注 REMARKS
28	BE8-E443G-00	.排气管 .PIPE, DRAIN 2	1	1	
29	97707-50025	.自攻螺钉 .SCREW, TAPPING	6	6	
30	BE8-E443E-00	.排水管 .PIPE, DRAIN	1	1	
31	90467-12804	.卡环 .CLIP	1	1	
32	90338-13800	.塞 .PLUG	1	1	
33	90467-11800	.卡环 .CLIP	1	1	
34	90387-064W3	轴套 COLLAR	1	1	
35	90480-13013	橡胶垫 GROMMET	3	3	
36	90520-10811	面板减震器 DAMPER, PLATE	1	1	
37	90520-10825	面板减震器 DAMPER, PLATE	1	1	
38	90520-15004	面板减震器 DAMPER, PLATE	1	1	
39	90450-46803	软管夹组合 HOSE CLAMP ASSY	1	1	
40	95812-06025	凸缘螺栓 BOLT, FLANGE	1	1	
41	BE8-E1166-00	通气管1 PIPE, BREATHER 1	1	1	
42	90467-13042	卡环 CLIP	1	1	
43	90467-13813	卡环 CLIP	1	1	

FIG. 9 曲轴箱

CRANKCASE

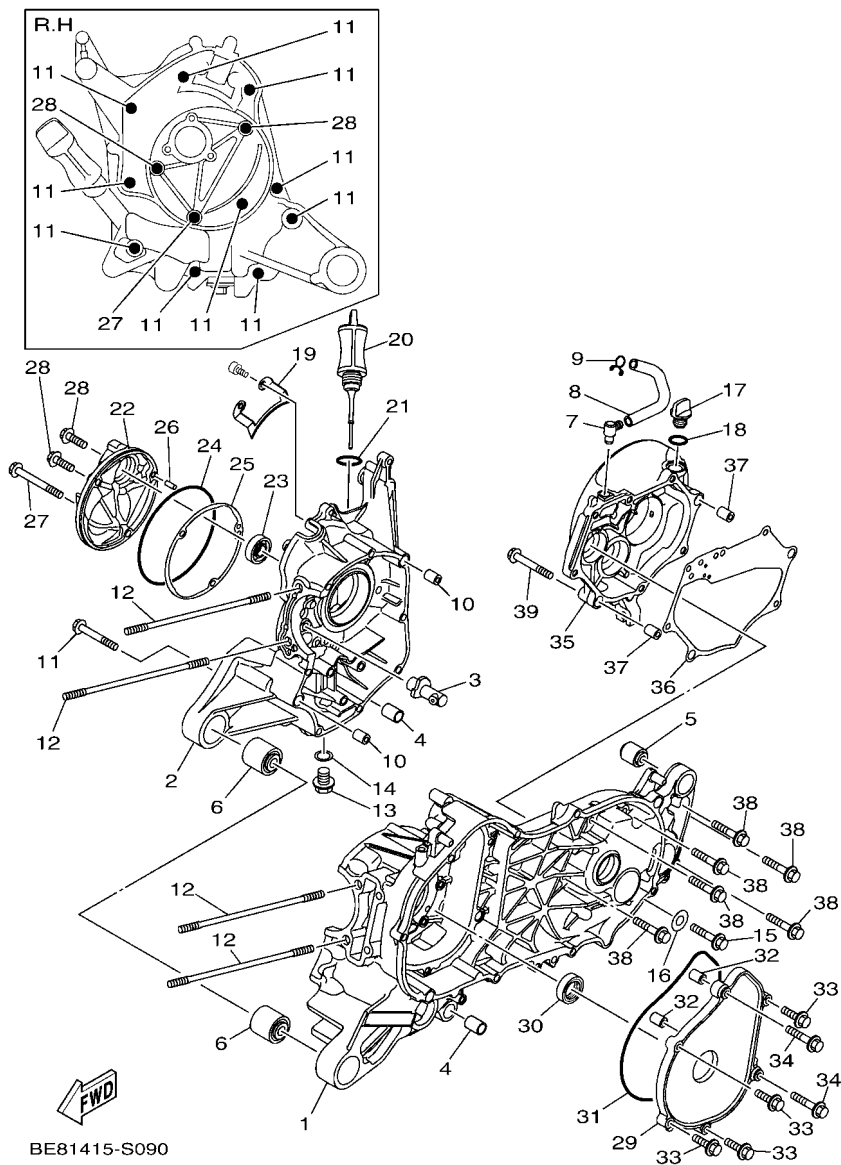

参照 号码	零件号码 PART NO.	零件名称 DESCRIPTION	BK91	BK92	备注 REMARKS
1	BE8-E5111-00	曲轴箱1 CRANKCASE 1	1	1	
2	BE8-E5121-00	曲轴箱2 CRANKCASE 2	1	1	
3	BE8-E5155-00	喷头3 NOZZLE 3	1	1	
4	BE8-F7121-00	制动轴 BUSH	2	2	
5	90388-08803	减震垫 DAMPER	1	1	
6	90388-10817	减震垫 DAMPER	2	2	
7	BE8-E5346-00	通气孔1 BREATHER 1	1	1	
8	BE8-E5373-00	通气管 PIPE, BREATHER	1	1	
9	90467-10008	卡环 CLIP	1	1	
10	99530-10114	定位销 PIN, DOWEL	2	2	
11	95022-06060	凸缘螺栓 BOLT, FLANGE	10	10	
12	BE8-E1391-00	双头螺栓1 BOLT, STUD 1	4	4	
13	90340-12806	螺塞 PLUG, STRAIGHT SCREW	1	1	
14	90201-12172	平垫圈 WASHER, PLATE	1	1	
15	95812-06040	凸缘螺栓 BOLT, FLANGE	1	1	
16	90430-06014	衬垫 GASKET	1	1	
17	4KL-E5363-00	机油塞 PLUG, OIL	1	1	
18	93210-14104	O型环 O-RING	1	1	
19	BE8-E5113-00	面板 PLATE	1	1	
20	BE8-E5362-00	油标塞 PLUG, OIL LEVEL	1	1	
21	5WG-E3769-00	O型环 O-RING	1	1	
22	BE8-E5417-00	盖 1 COVER, CAP	1	1	
23	93102-19820	油封 OIL SEAL	1	1	
24	93211-07805	O型环 O-RING	1	1	
25	BE8-E5453-00	化油器盖衬垫 GASKET	1	1	
26	99480-05010	销 PIN	1	1	
27	95022-06070	凸缘螺栓 BOLT, FLANGE	1	1	

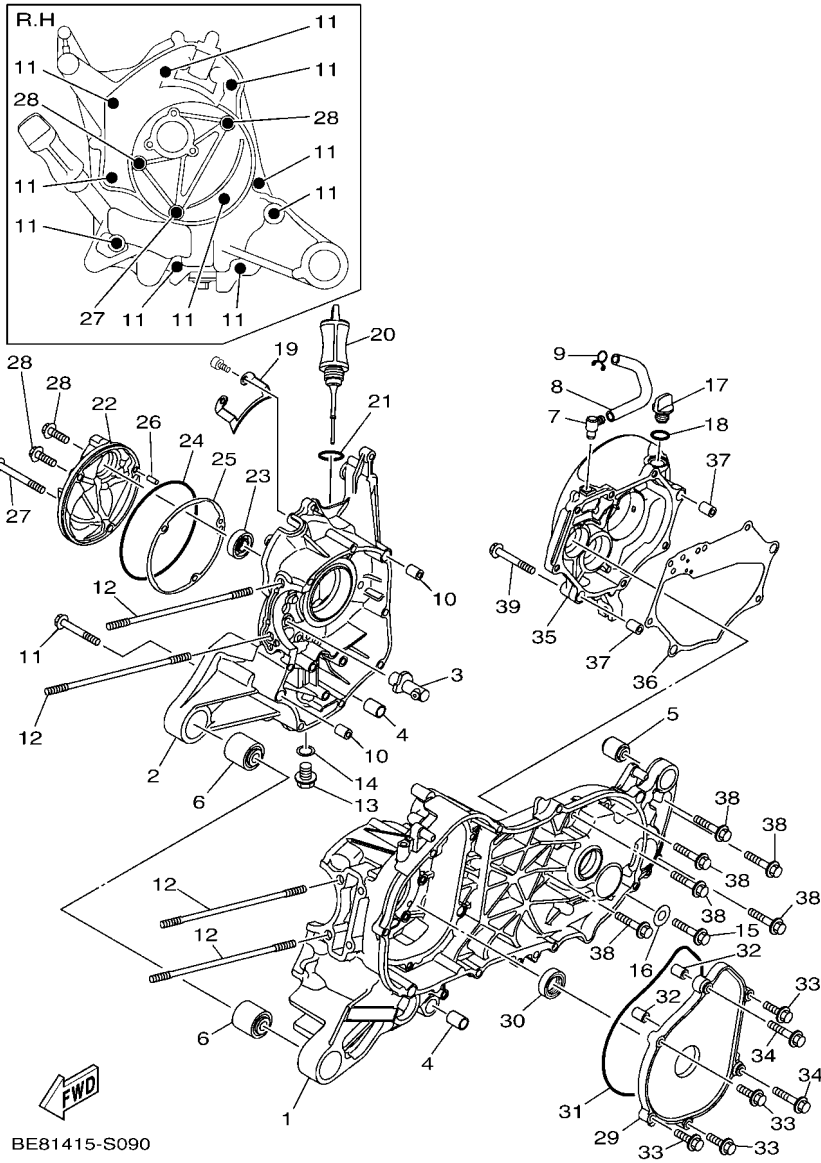

FIG. 9 曲轴箱

CRANKCASE

参照 号码	零件号码 PART NO.	零件名称 DESCRIPTION	BK91	BK92	备注 REMARKS
28	95022-06020	凸缘螺栓 BOLT, FLANGE	2	2	
29	BE8-E5423-00	化油器盖2 COVER 2	1	1	
30	93102-25823	油封 OIL SEAL	1	1	
31	93211-47800	O 型环 O-RING	1	1	
32	99530-10114	定位销 PIN, DOWEL	2	2	
33	95022-06025	凸缘螺栓 BOLT, FLANGE	4	4	
34	95022-06035	凸缘螺栓 BOLT, FLANGE	2	2	
35	BE8-E5421-00	曲轴箱盖2 COVER, CRANKCASE 2	1	1	
36	BE8-E5461-00	曲轴箱盖衬垫2 GASKET, CRANKCASE COVER 2	1	1	
37	99530-10114	定位销 PIN, DOWEL	2	2	
38	95022-06035	凸缘螺栓 BOLT, FLANGE	6	6	
39	95022-06045	凸缘螺栓 BOLT, FLANGE	1	1	

FIG. 10 曲轴箱盖1

CRANKCASE COVER 1

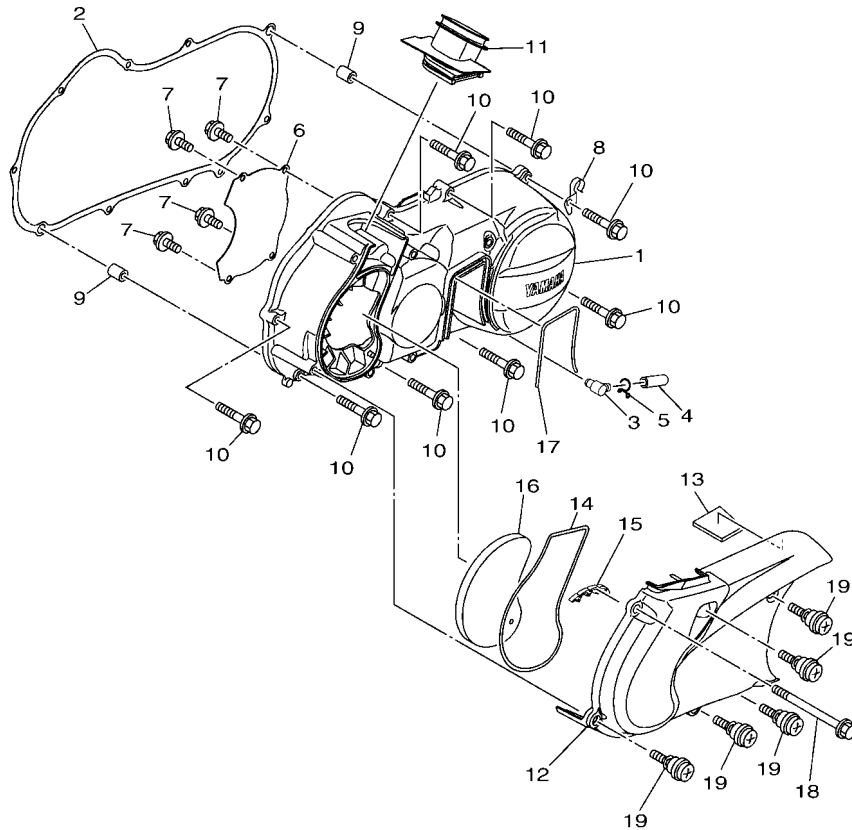

BE81415-S100

参照 号码	零件号码 PART NO.	零件名称 DESCRIPTION	BK91	BK92	备注 REMARKS
1	BE8-E5411-00	曲轴箱盖1 COVER, CRANKCASE 1	1	1	
2	BE8-E5451-00	曲轴箱盖衬垫1 GASKET, CRANKCASE COVER 1	1	1	
3	BE8-E5346-00	通气孔1 BREATHER 1	1	1	
4	BE8-E443H-00	排流管 PIPE, DRAIN 3	1	1	
5	90467-110A3	卡环 CLIP	1	1	
6	BE8-E5191-00	面板 PLATE	1	1	
7	95022-06010	凸缘螺栓 BOLT, FLANGE	4	4	
8	90462-10822	夹箍 CLAMP	1	1	
9	99530-10114	定位销 PIN, DOWEL	2	2	
10	95022-06035	凸缘螺栓 BOLT, FLANGE	8	8	
11	BE8-E5473-00	空气导管 DUCT, AIR	1	1	
12	BE8-E5333-00	盖 COVER	1	1	
13	2TD-E5316-00	减震器1 DAMPER 1	1	1	
14	BE8-E5472-00	空气导管密封圈 SEAL, AIR DUCT	1	1	
15	BE8-E5495-00	保护件密封圈1 SEAL, PROTECTOR 1	1	1	
16	BE8-E5407-00	滤芯1 ELEMENT 1	1	1	
17	BE8-E5474-00	空气导管密封 SEAL, AIR DUCT	1	1	
18	95822-06090	凸缘螺栓 BOLT, FLANGE	1	1	
19	1CC-E5481-00	螺栓1 BOLT 1	5	5	

FIG. 11 起动器

STARTER

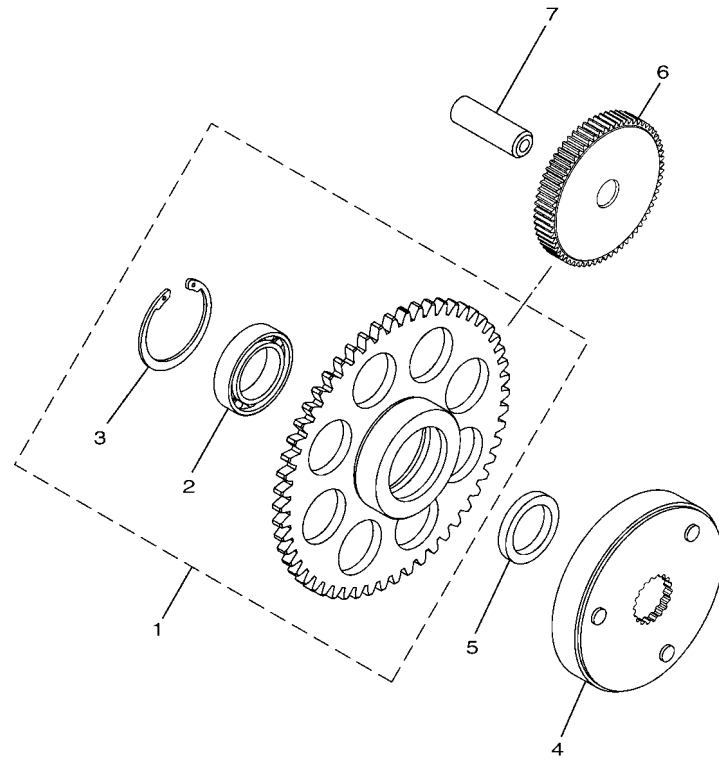

参照 号码	零件号码 PART NO.	零件名称 DESCRIPTION	BK91	BK92	备注 REMARKS
1	BE8-E5520-00	起动轮组合 STARTER WHEEL ASSY	1	1	
2	2XC-E5693-00	.轴承 .BEARING	1	1	
3	93450-32837	.卡环 .CIRCLIP	1	1	
4	BE8-E5570-00	起动离合器组合 STARTER CLUTCH ASSY	1	1	
5	BE8-E5598-00	衬套 COLLAR	1	1	
6	BE8-E5512-00	惰齿轮1 GEAR, IDLER 1	1	1	
7	BE8-E5521-00	轴1 SHAFT 1	1	1	



BE81415-S110

FIG. 12 离合器

CLUTCH

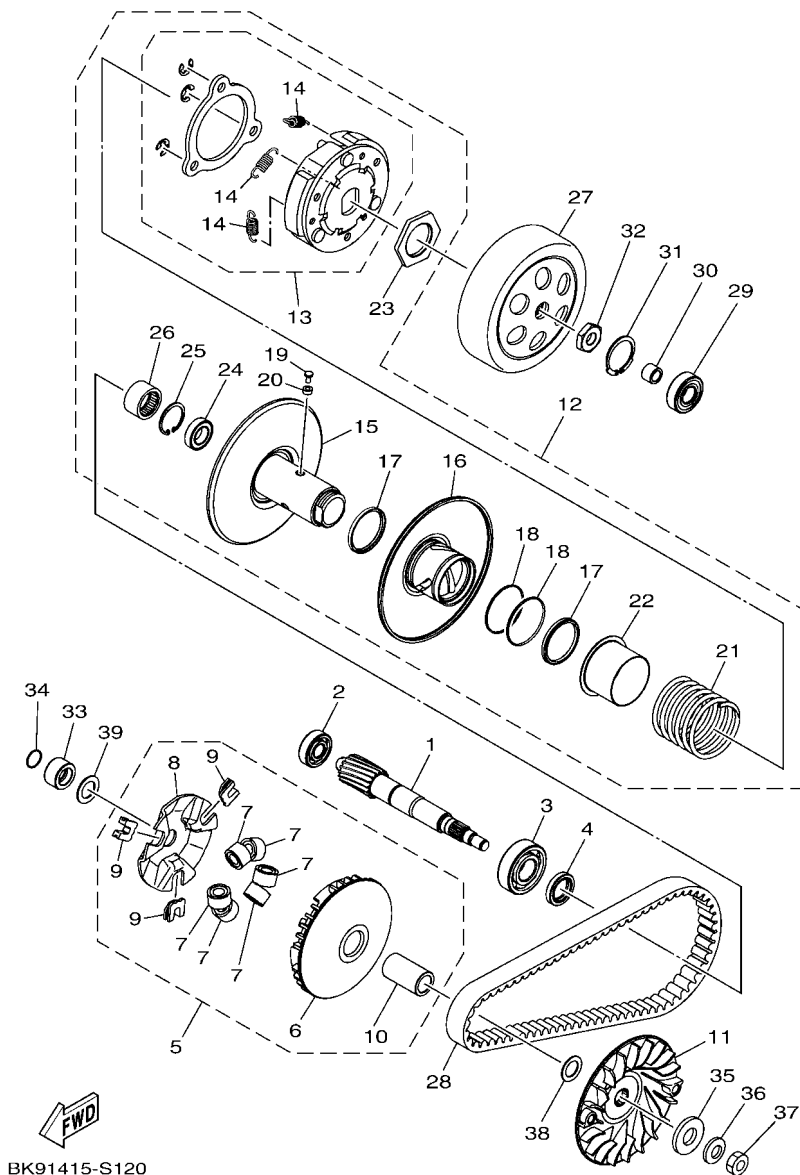

BK91415-S120

参照 号码	零件号码 PART NO.	零件名称 DESCRIPTION	BK91	BK92	备注 REMARKS
1	BK9-E6111-00	初级驱动齿轮 GEAR, PRIMARY DRIVE	1	1	
2	93306-201YS	轴承 BEARING	1	1	
3	93306-204XX	轴承 BEARING	1	1	
4	93102-20817	油封 OIL SEAL	1	1	
5	BE8-E7601-00	主槽轮组合 PRIMARY SHEAVE ASSY	1	1	
6	BE8-E7620-00	主滑轮组合 PRIMARY SLIDING SHEAVE COMP.	1	1	
7	BE8-E7632-00	重锤 WEIGHT	6	6	
8	BE8-E7623-00	凸轮 CAM	1	1	
9	4KL-E7653-20	滑块 SLIDER	3	3	
10	BE8-E7674-00	导向 COLLAR, GUIDE	1	1	
11	BE8-E7611-00	主固定槽 SHEAVE, PRIMARY FIXED	1	1	
12	BE8-E7602-00	副槽轮组合 SECONDARY SHEAVE ASSY	1	1	
13	BE8-E6620-00	离合器载架组合 CLUTCH CARRIER ASSY	1	1	
14	BE8-E6626-00	离合器重锤弹簧1 SPRING, CLUTCH WEIGHT 1	3	3	
15	BE8-E7660-00	副固定槽轮组合 SECONDARY FIXED SHEAVE COMP.	1	1	
16	BE8-E7670-00	副滑轮 SECONDARY SLIDING SHEAVE	1	1	
17	BE8-E7465-00	毡密封 SEAL	2	2	
18	BE8-E7465-10	毡密封 SEAL	2	2	
19	BE8-E7664-00	导承销 PIN, GUIDE	3	3	
20	BE8-E7674-10	导向 COLLAR, GUIDE	3	3	
21	BE8-E7683-00	辅助弹簧 SPRING, SECONDARY	1	1	
22	BE8-E7684-00	辅助弹簧座 SEAT, SECONDARY SPRING	1	1	
23	BE8-E7668-00	螺母 NUT	1	1	
24	BE8-E7678-00	轴承 BEARING	1	1	
25	BE8-E5744-00	开口簧 CIRCLIP	1	1	
26	BE8-E7678-10	轴承 BEARING	1	1	
27	BE8-E6611-00	离合器壳体组合 CLUTCH HOUSING COMP.	1	1	

FIG. 12 离合器

CLUTCH

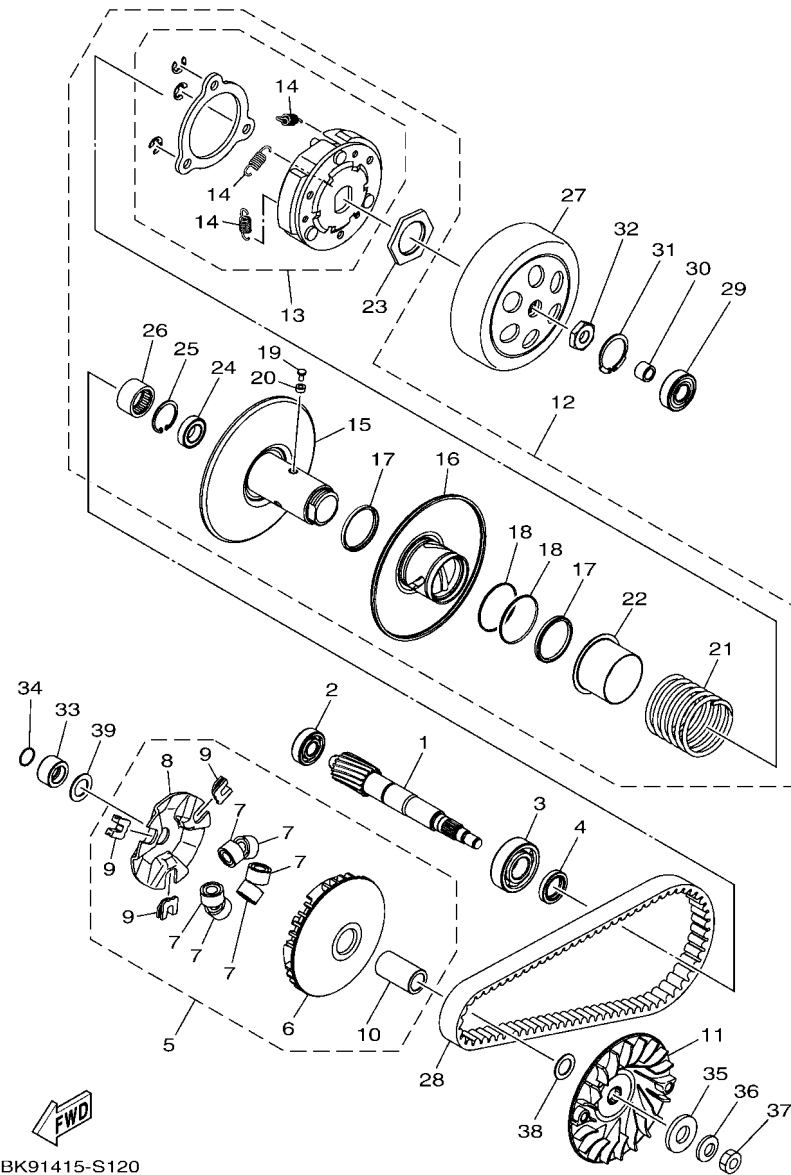

BK91415-S120

参照 号码	零件号码 PART NO.	零件名称 DESCRIPTION	BK91	BK92	备注 REMARKS
28	BE8-E7641-00	V型皮带 V-BELT	1	1	
29	933A6-202Y0	轴承 BEARING	1	1	
30	90380-10802	固体套管 BUSH, SOLID	1	1	
31	99009-35700	卡环 CIRCLIP	1	1	
32	90170-12802	螺母 NUT	1	1	
33	BE8-E7645-00	安装 COLLAR	1	1	
34	93210-16807	O型环 O-RING	1	1	
35	90201-165H4	平垫圈 WASHER, PLATE	1	1	
36	90208-12809	弹性挡圈 WASHER, CONICAL SPRING	1	1	
37	90170-12800	螺母 NUT	1	1	
38	90201-15848	平垫圈 WASHER, PLATE	1	1	
39	90201-16816	平垫圈 WASHER, PLATE	1	1	

FIG. 13 传动

TRANSMISSION

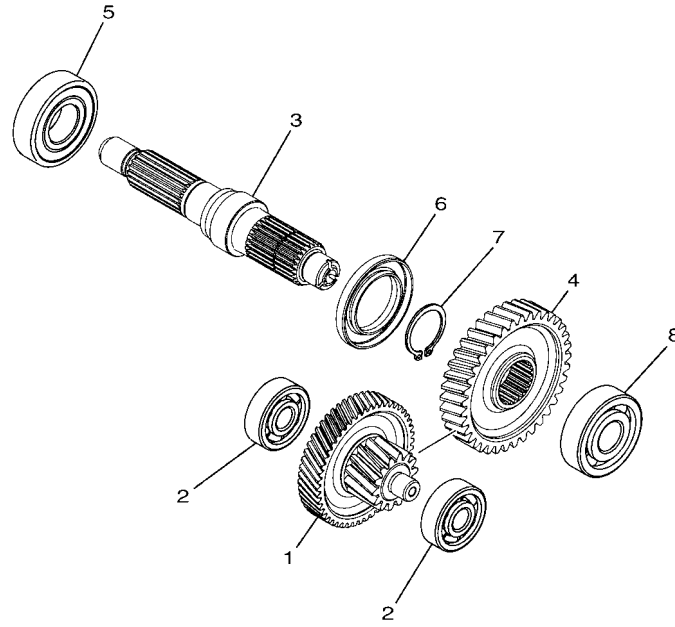

参照 号码	零件号码 PART NO.	零件名称 DESCRIPTION	BK91	BK92	备注 REMARKS
1	BK9-E7410-00	主轮轴组 MAIN AXLE COMP. (15T/50T)	1	1	
2	93306-351Y8	轴承 BEARING	2	2	
3	BE8-E7421-00	驱动轴 AXLE, DRIVE	1	1	
4	BE8-E7211-00	一档从动齿轮 GEAR, 1ST WHEEL (36T)	1	1	
5	93306-272YB	轴承 BEARING	1	1	
6	93102-32810	油封 OIL SEAL	1	1	
7	99009-25400	卡环 CIRCLIP	1	1	
8	93306-303YU	轴承 BEARING	1	1	



2BM1422-P130

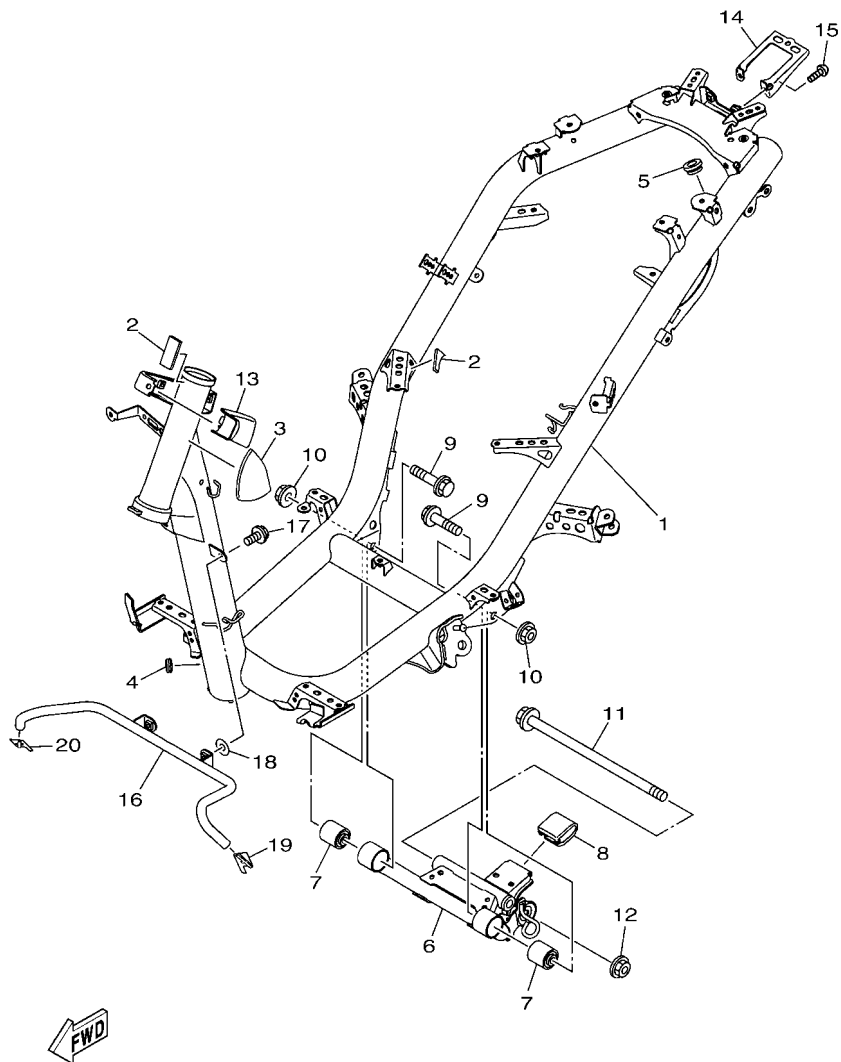

BK91415-S140

FIG. 14 车架

FRAME

参照 号码	零件号码 PART NO.	零件名称 DESCRIPTION	BK91	BK92	备注 REMARKS
1	BK9-F1110-00	车架组合 FRAME COMP.	1	1	
2	90520-02823	面板减震器 DAMPER, PLATE	2	2	
3	90520-02829	面板减震器 DAMPER, PLATE	1	1	
4	90480-12237	橡胶垫 GROMMET	1	1	
5	90480-16804	橡胶垫 GROMMET	1	1	
6	BE8-F1410-00	发动机托架组合 ENGINE BRACKET COMP.	1	1	
7	90388-10817	减震垫 DAMPER	2	2	
8	BK9-F7114-00	主支承限位板 STOPPER, MAIN STAND	1	1	
9	90105-10210	凸缘螺栓 BOLT, FLANGE	2	2	
10	95602-10200	自锁螺母 NUT, S/L FLANGE	2	2	
11	BE8-F2141-00	后臂转轴 SHAFT, PIVOT	1	1	
12	95602-10200	自锁螺母 NUT, S/L FLANGE	1	1	
13	BK9-F834V-00	保护件1 PROTECTOR 1	1	1	
14	BK9-F1640-00	后支承组 REAR STAY COMP.	1	1	
15	91312-06012	螺栓 BOLT	2	2	
16	BK9-F116B-00	托架 BRKT.	1	1	
17	95802-06012	凸缘螺栓 BOLT, FLANGE	2	2	
18	90201-062G3	平垫圈 WASHER, PLATE	2	2	
19	BK9-F191B-00	板1 PLATE 1	1	1	
20	BK9-F191C-00	板2 PLATE 2	1	1	

FIG. 15 挡泥板

FENDER

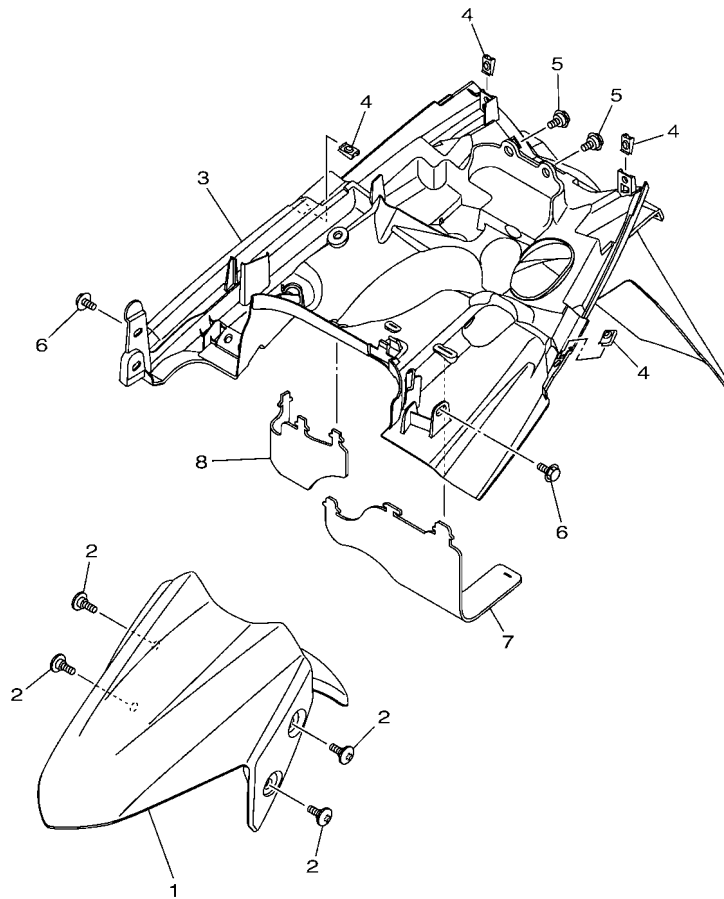

参照 号码	零件号码 PART NO.	零件名称 DESCRIPTION	BK91	BK92	备注 REMARKS
1	BK9-F1511-00-P0	前挡泥板 FENDER, FRONT	1	1	A车用 FOR A
	BK9-F1511-00-P1	前挡泥板 FENDER, FRONT	1	1	B车用 FOR B
	BK9-F1511-00-P2	前挡泥板 FENDER, FRONT	1	1	C, F (BK92), H车用 FOR C, F(BK92), H
	BK9-F1511-00-P3	前挡泥板 FENDER, FRONT	1	1	D, G (BK92), J车用 FOR D, G(BK92), J
	BK9-F1511-00-UG	前挡泥板 FENDER, FRONT	1	1	E车用 FOR E
	BK9-F1511-00-P4	前挡泥板 FENDER, FRONT	1		F (BK91) 车用 FOR F(BK91)
	BK9-F1511-00-P5	前挡泥板 FENDER, FRONT	1		G (BK91) 车用 FOR G(BK91)
2	90154-06807	夹紧螺钉 SCREW, BINDING	4	4	
3	BK9-F1611-00	后挡泥板 FENDER, REAR	1	1	
4	90183-05818	弹性螺母 NUT, SPRING	4	4	
5	90109-06202	螺栓 BOLT	2	2	
6	90119-06155	带垫螺栓 BOLT, WITH WASHER	2	2	
7	BK9-F1621-00	挡板 FLAP	1	1	
8	BK9-F1691-00	挡板 FLAP	1	1	



BK91415-S150

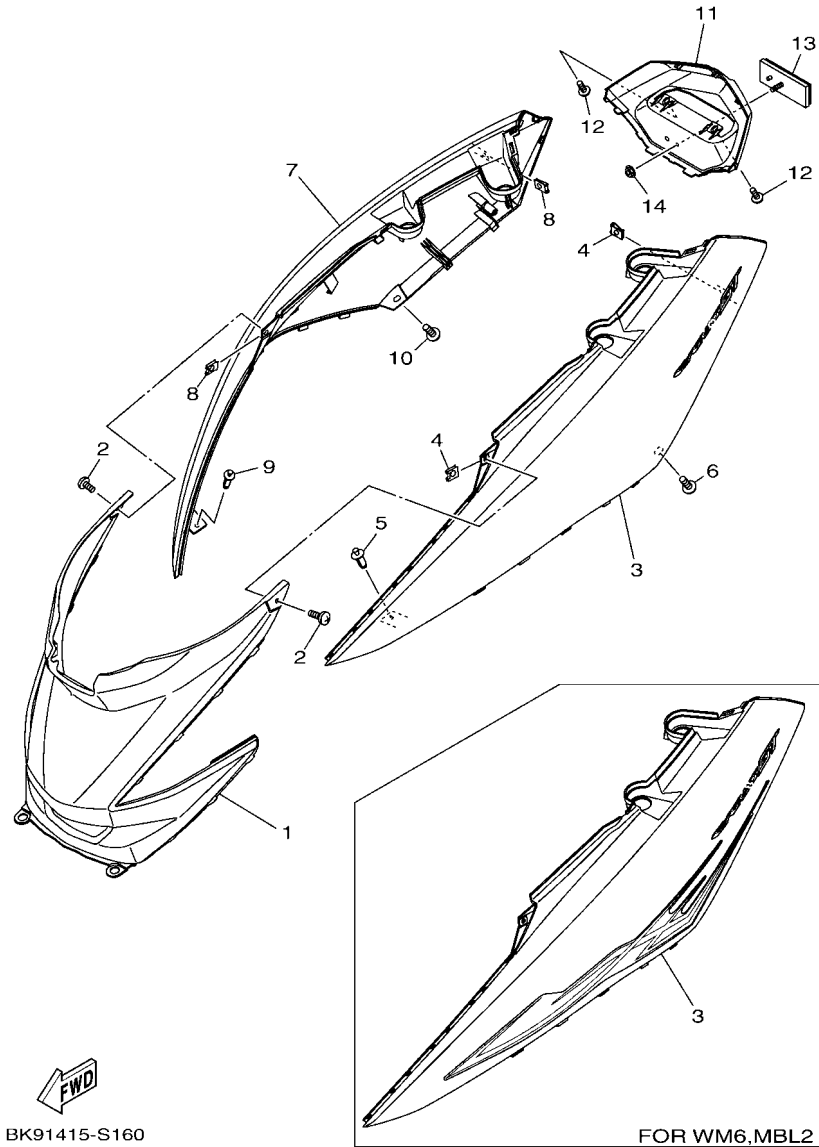

BK91415-S160

FIG. 16 侧盖

SIDE COVER

参照 号码	零件号码 PART NO.	零件名称 DESCRIPTION	BK91	BK92	备注 REMARKS
1	BK9-F1711-00	侧盖1 COVER, SIDE 1	1	1	A, B, F, G, H, J车用 FOR A,B,F,G,H,J
	BK9-F1711-10	侧盖1 COVER, SIDE 1	1	1	C, D, E车用 FOR C,D,E
2	97707-50012	自攻螺钉 SCREW, TRUSS HEAD TAPPING	2	2	
3	BK9-W2172-00-P0	侧盖2 SIDE COVER 2	1	1	A车用 FOR A
	BK9-W2172-00-P1	侧盖2 SIDE COVER 2	1	1	B车用 FOR B
	BK9-W2172-00-P2	侧盖2 SIDE COVER 2	1	1	C, F (BK92), H车用 FOR C,F(BK92),H
	BK9-W2172-00-P3	侧盖2 SIDE COVER 2	1	1	D, G (BK92), J车用 FOR D,G(BK92),J
	BK9-W2172-00-UG	侧盖2 SIDE COVER 2	1	1	E车用 FOR E
	BK9-W2172-00-P4	侧盖2 SIDE COVER 2	1		F (BK91) 车用 FOR F(BK91)
	BK9-W2172-00-P5	侧盖2 SIDE COVER 2	1		G (BK91) 车用 FOR G(BK91)
4	90183-05818	弹性螺母 NUT, SPRING	2	2	
5	90269-06809	铆钉 RIVET	1	1	
6	97707-50016	自攻螺钉 SCREW, TRUSS HEAD TAPPING	1	1	
7	BK9-W2173-00-P0	侧盖3 SIDE COVER 3	1	1	A车用 FOR A
	BK9-W2173-00-P1	侧盖3 SIDE COVER 3	1	1	B车用 FOR B
	BK9-W2173-00-P2	侧盖3 SIDE COVER 3	1	1	C, F (BK92), H车用 FOR C,F(BK92),H
	BK9-W2173-00-P3	侧盖3 SIDE COVER 3	1	1	D, G (BK92), J车用 FOR D,G(BK92),J
	BK9-W2173-00-UG	侧盖3 SIDE COVER 3	1	1	E车用 FOR E
	BK9-W2173-00-P4	侧盖3 SIDE COVER 3	1		F (BK91) 车用 FOR F(BK91)
	BK9-W2173-00-P5	侧盖3 SIDE COVER 3	1		G (BK91) 车用 FOR G(BK91)
8	90183-05818	弹性螺母 NUT, SPRING	2	2	
9	90269-06809	铆钉 RIVET	1	1	
10	97707-50016	自攻螺钉 SCREW, TRUSS HEAD TAPPING	1	1	
11	BK9-W217F-00	侧面盖5 COVER, SIDE 5	1	1	
12	97707-50012	自攻螺钉 SCREW, TRUSS HEAD TAPPING	2	2	
13	4P7-H5130-20	后反射镜组合 REAR REFLECTOR ASSY	1	1	
14	95602-05200	自锁螺母 NUT, SELF-LOCKING	1	1	

FIG. 18 操纵系统

STEERING

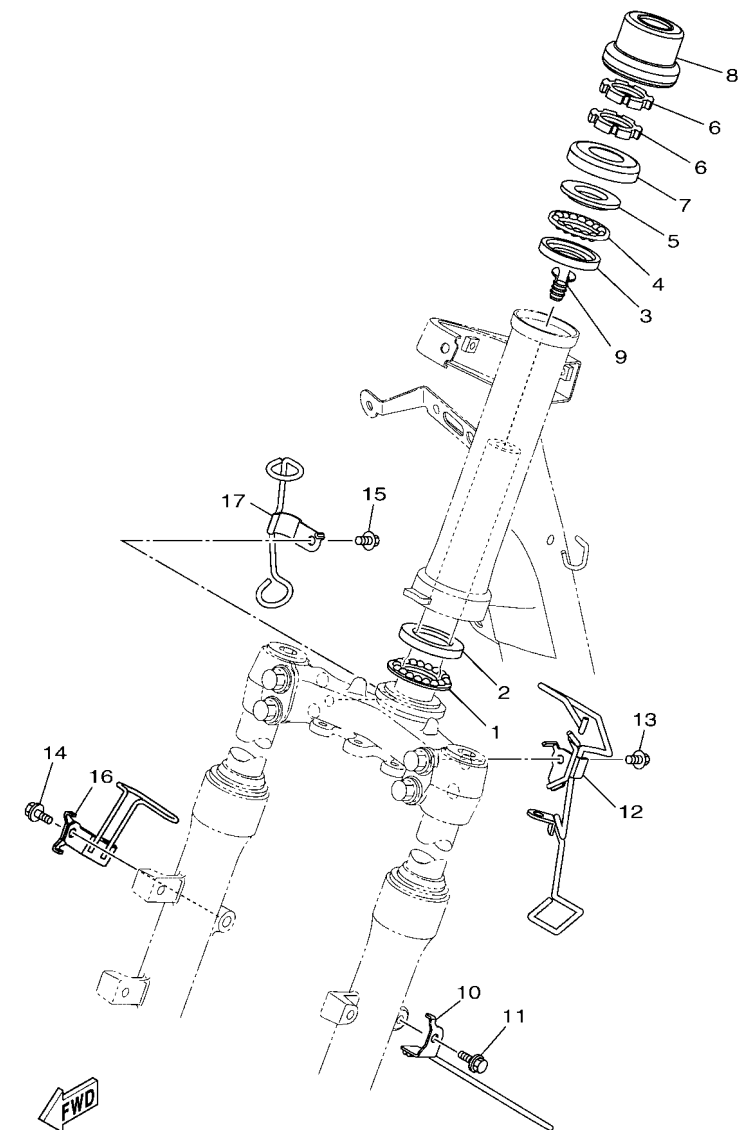

BK91415-S180

参照 号码	零件号码 PART NO.	零件名称 DESCRIPTION	BK91	BK92	备注 REMARKS
1	5WG-F341E-00	保持架 RETAINER, BALL BEARING	1		
2	4KL-F3412-20	轴承座圈2 RACE, BALL 2	1		
3	4KL-F3412-30	轴承座圈2 RACE, BALL 2	1		
4	5WG-F341E-10	保持架 RETAINER, BALL BEARING	1		
5	4KL-F3411-10	轴承座圈1 RACE, BALL 1	1		
6	90179-25812	螺母 NUT	2		
7	5MH-F3416-01	滚珠座圈盖2 COVER, BALL RACE 2	1		
8	BK9-F3415-00	滚珠座圈盖1 COVER, BALL RACE 1	1		
9	BK9-F312G-00	孔塞 PLUG	1		
10	BK9-F3317-00	钢索支架 HOLDER, CABLE	1		
11	95022-06012	凸缘螺栓 BOLT, FLANGE	1		
12	BK9-F3857-00	锁紧垫 HOLDER	1		
13	95022-06012	凸缘螺栓 BOLT, FLANGE	1		
14	95022-06012	凸缘螺栓 BOLT, FLANGE	1		
15	95022-06012	凸缘螺栓 BOLT, FLANGE	1		
16	BK9-F5875-00	制动软管支架1 HOLDER, BRAKE HOSE 1	1		
17	BK9-F5887-00	制动软管支架 HOLDER, BRAKE HOSE	1		

FIG. 19 操纵系统2

STEERING 2

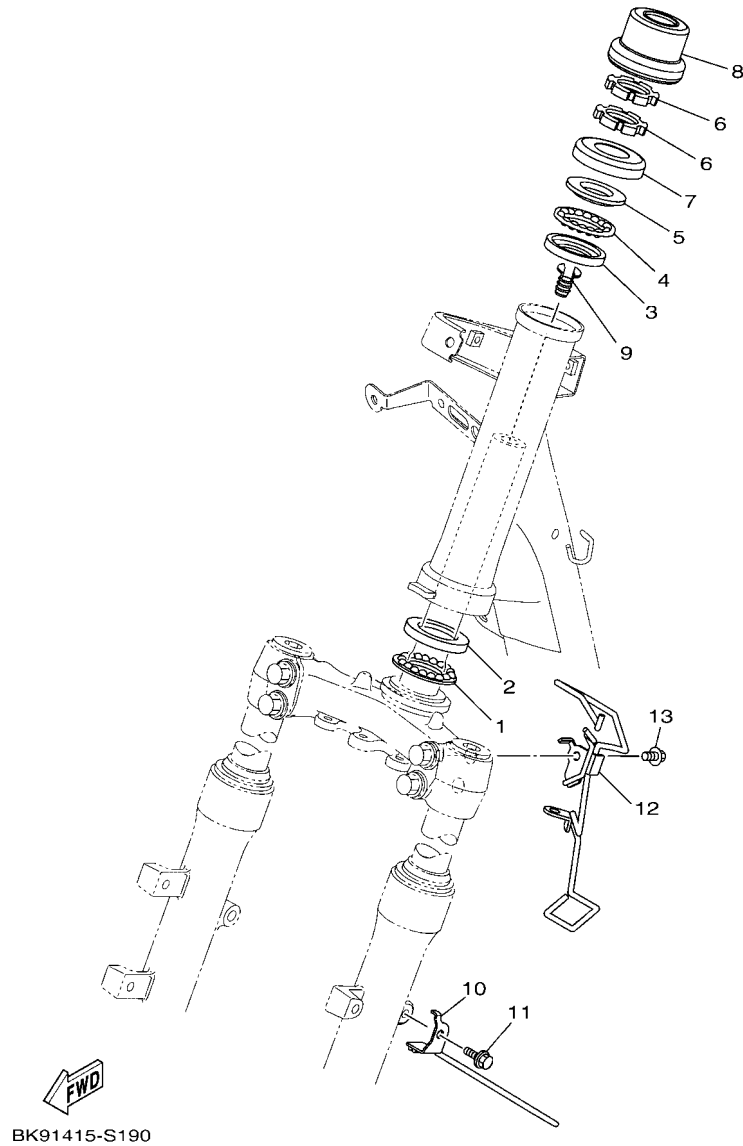

BK91415-S190

参照 号码	零件号码 PART NO.	零件名称 DESCRIPTION	BK91	BK92	备注 REMARKS
1	5WG-F341E-00	保持架 RETAINER, BALL BEARING		1	
2	4KL-F3412-20	轴承座圈2 RACE, BALL 2		1	
3	4KL-F3412-30	轴承座圈2 RACE, BALL 2		1	
4	5WG-F341E-10	保持架 RETAINER, BALL BEARING		1	
5	4KL-F3411-10	轴承座圈1 RACE, BALL 1		1	
6	90179-25812	螺母 NUT		2	
7	5MH-F3416-01	滚珠座圈盖2 COVER, BALL RACE 2		1	
8	BK9-F3415-00	滚珠座圈盖1 COVER, BALL RACE 1		1	
9	BK9-F312G-00	孔塞 PLUG		1	
10	BK9-F3317-00	钢索支架 HOLDER, CABLE		1	
11	95022-06012	凸缘螺栓 BOLT, FLANGE		1	
12	BK9-F3857-00	锁紧垫 HOLDER		1	
13	95022-06012	凸缘螺栓 BOLT, FLANGE		1	

FIG. 20 前叉(碟刹)

FRONT FORK FOR DISK BRAKE

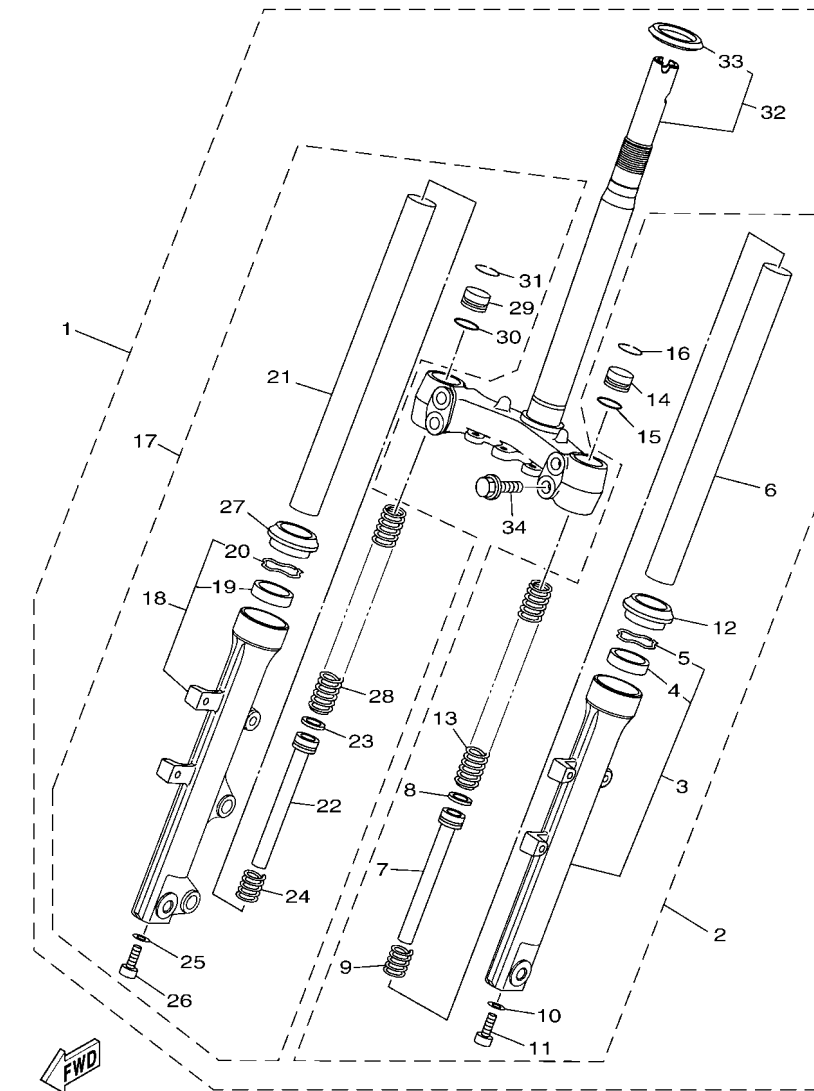

BK91415-S200

参照 号码	零件号码 PART NO.	零件名称 DESCRIPTION	BK91	BK92	备注 REMARKS
1	BK9-F3100-00	前叉组合 FRONT FORK ASSY	1		
2	BK9-F3102-00	.前叉组合(左边) .FRONT FORK ASSY (L.H)	1		
3	BK9-F3106-00	.外管组件(左边) .OUTER TUBE COMP.	1		
4	BE8-F3145-00	...油封 ...OIL SEAL	1		
5	4RT-F3153-00	...扣环 ...RING, SNAP	1		
6	BE8-F3110-00	.内管组件1 .INNER TUBE COMP.1	1		
7	BE8-F3171-00	.前叉气缸组 .PISTON, FRONT FORK	1		
8	1FP-F3157-00	.前叉活塞环 .RING, PISTON	1		
9	49P-F3151-00	.回弹弹簧 .SPRING, REBOUND	1		
10	1FP-F3479-00	.衬垫 .GASKET	1		
11	1FP-F3356-00	.螺栓2 .BOLT 2	1		
12	BE8-F3144-00	.防尘罩 .SEAL, DUST	1		
13	BE8-F3141-00	.前叉弹簧 .SPRING, FRONT FORK	1		
14	1FP-F3111-00	.顶盖螺栓 .BOLT, CAP	1		
15	1FP-F3147-00	.O型环 .O-RING	1		
16	1FP-F3183-00	.开口簧环, 卡 .CIRCLIP	1		
17	BK9-F3103-00	.前叉组合(右边) .FRONT FORK ASSY (R.H)	1		
18	BK9-F3107-00	.外管组件(右边) .OUTER TUBE COMP.	1		
19	BE8-F3145-00	...油封 ...OIL SEAL	1		
20	4RT-F3153-00	...扣环 ...RING, SNAP	1		
21	BE8-F3110-00	.内管组件1 .INNER TUBE COMP.1	1		
22	BE8-F3171-00	.前叉气缸组 .PISTON, FRONT FORK	1		
23	1FP-F3157-00	.前叉活塞环 .RING, PISTON	1		
24	49P-F3151-00	.回弹弹簧 .SPRING, REBOUND	1		
25	1FP-F3479-00	.衬垫 .GASKET	1		
26	1FP-F3356-00	.螺栓2 .BOLT 2	1		
27	BE8-F3144-00	.防尘罩 .SEAL, DUST	1		

FIG. 21 前叉(鼓刹)

FRONT FORK FOR DRUM BRAKE

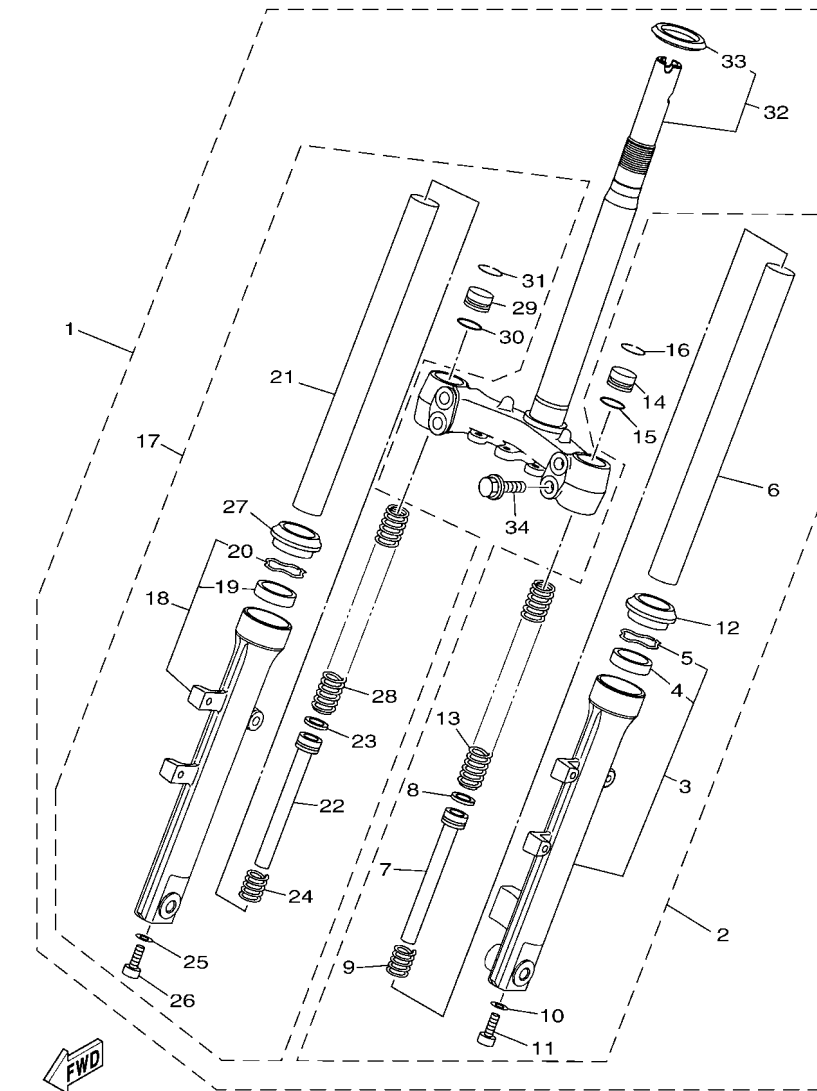

BK91415-S210

参照 号码	零件号码 PART NO.	零件名称 DESCRIPTION	BK91	BK92	备注 REMARKS
1	BK9-F3100-10	前叉组合 FRONT FORK ASSY		1	
2	BK9-F3102-10	.前叉组合(左边) .FRONT FORK ASSY (L.H)		1	
3	BK9-F3106-10	.外管组件(左边) .OUTER TUBE COMP.		1	
4	BE8-F3145-00	...油封 ...OIL SEAL		1	
5	4RT-F3153-00	...扣环 ...RING, SNAP		1	
6	BE8-F3110-00	.内管组件1 .INNER TUBE COMP.1		1	
7	BE8-F3171-00	.前叉气缸组 .PISTON, FRONT FORK		1	
8	1FP-F3157-00	.前叉活塞环 .RING, PISTON		1	
9	49P-F3151-00	.回弹弹簧 .SPRING, REBOUND		1	
10	1FP-F3479-00	.衬垫 .GASKET		1	
11	1FP-F3356-00	.螺栓2 .BOLT 2		1	
12	BE8-F3144-00	.防尘罩 .SEAL, DUST		1	
13	BE8-F3141-00	.前叉弹簧 .SPRING, FRONT FORK		1	
14	1FP-F3111-00	.顶盖螺栓 .BOLT, CAP		1	
15	1FP-F3147-00	.O型环 .O-RING		1	
16	1FP-F3183-00	.开口簧环, 卡 .CIRCLIP		1	
17	BK9-F3103-10	.前叉组合(右边) .FRONT FORK ASSY (R.H)		1	
18	BK9-F3107-10	.外管组件(右边) .OUTER TUBE COMP.		1	
19	BE8-F3145-00	...油封 ...OIL SEAL		1	
20	4RT-F3153-00	...扣环 ...RING, SNAP		1	
21	BE8-F3110-00	.内管组件1 .INNER TUBE COMP.1		1	
22	BE8-F3171-00	.前叉气缸组 .PISTON, FRONT FORK		1	
23	1FP-F3157-00	.前叉活塞环 .RING, PISTON		1	
24	49P-F3151-00	.回弹弹簧 .SPRING, REBOUND		1	
25	1FP-F3479-00	.衬垫 .GASKET		1	
26	1FP-F3356-00	.螺栓2 .BOLT 2		1	
27	BE8-F3144-00	.防尘罩 .SEAL, DUST		1	

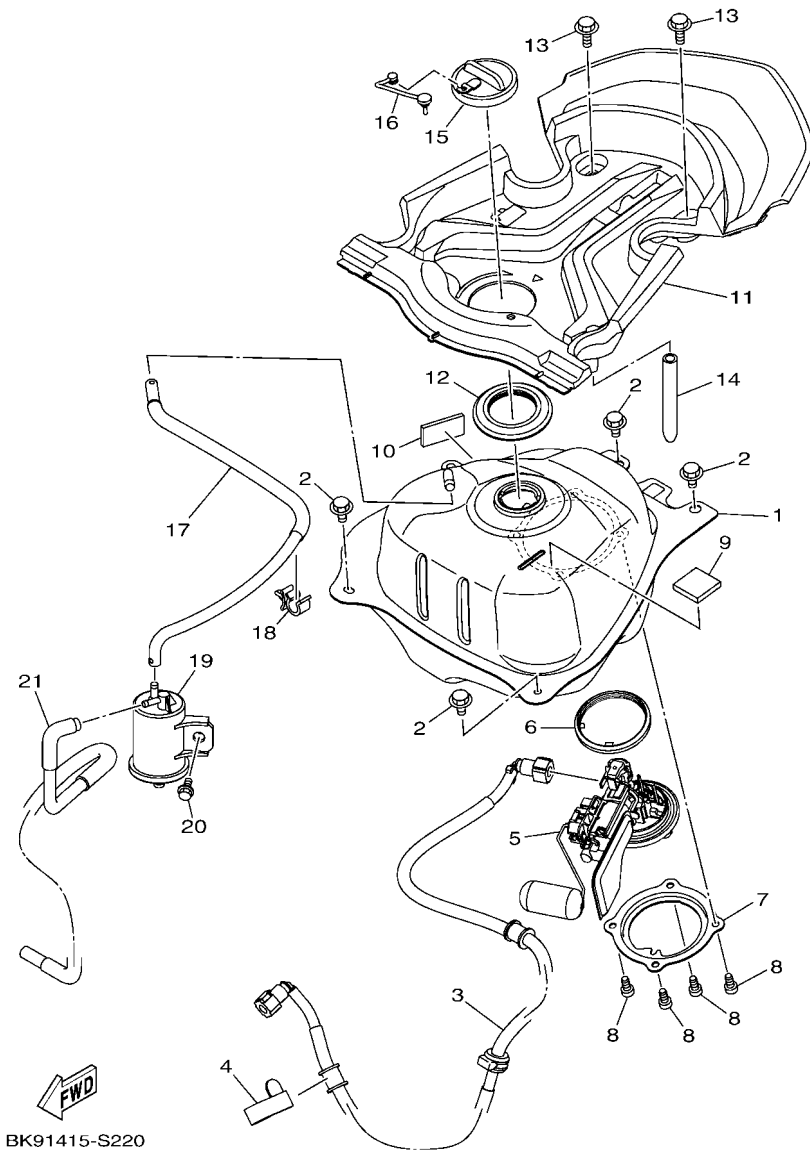

BK91415-S220

FIG. 22 油箱

FUEL TANK

参照 号码	零件号码 PART NO.	零件名称 DESCRIPTION	BK91	BK92	备注 REMARKS
1	BK9-F4110-00	油箱组合 FUEL TANK COMP.	1	1	
2	90119-06155	带垫螺栓 BOLT, WITH WASHER	4	4	
3	BE8-E3971-00	燃油管1 PIPE, FUEL 1	1	1	
4	90464-15806	线夹 CLAMP	1	1	
5	2PH-E3907-00	油泵组合 FUEL PUMP COMP.	1	1	
6	1DB-F414G-01	密封圈 SEAL	1	1	
7	BK9-F4491-00	燃油泵托架 BRACKET, FUEL PUMP	1	1	
8	91312-05010	螺栓 BOLT	4	4	
9	90520-02806	面板减震器 DAMPER, PLATE	1	1	
10	90520-02823	面板减震器 DAMPER, PLATE	1	1	
11	BK9-F41B1-00	侧盖缓冲垫 COVER, TANK	1	1	
12	BK9-F414E-00	密封 SEAL 2	1	1	
13	90119-068B7	带垫螺栓 BOLT, WITH WASHER	2	2	
14	91A11-07008	软管 TUBE, FLEXIBLE	1	1	
15	BE8-F4610-00	油箱盖总成 CAP ASSY	1	1	
16	BK9-F4633-00	滚珠链 CHAIN, BALL	1	1	
17	BK9-F4313-00	管3 PIPE 3	1	1	
18	90464-09805	线夹 CLAMP	1	1	
19	BE8-F4170-00	过滤缸总成 CANISTER ASSY	1	1	
20	90109-06202	螺栓 BOLT	1	1	
21	BK9-F4314-00	管4 PIPE 4	1	1	

FIG. 23 座位

SEAT

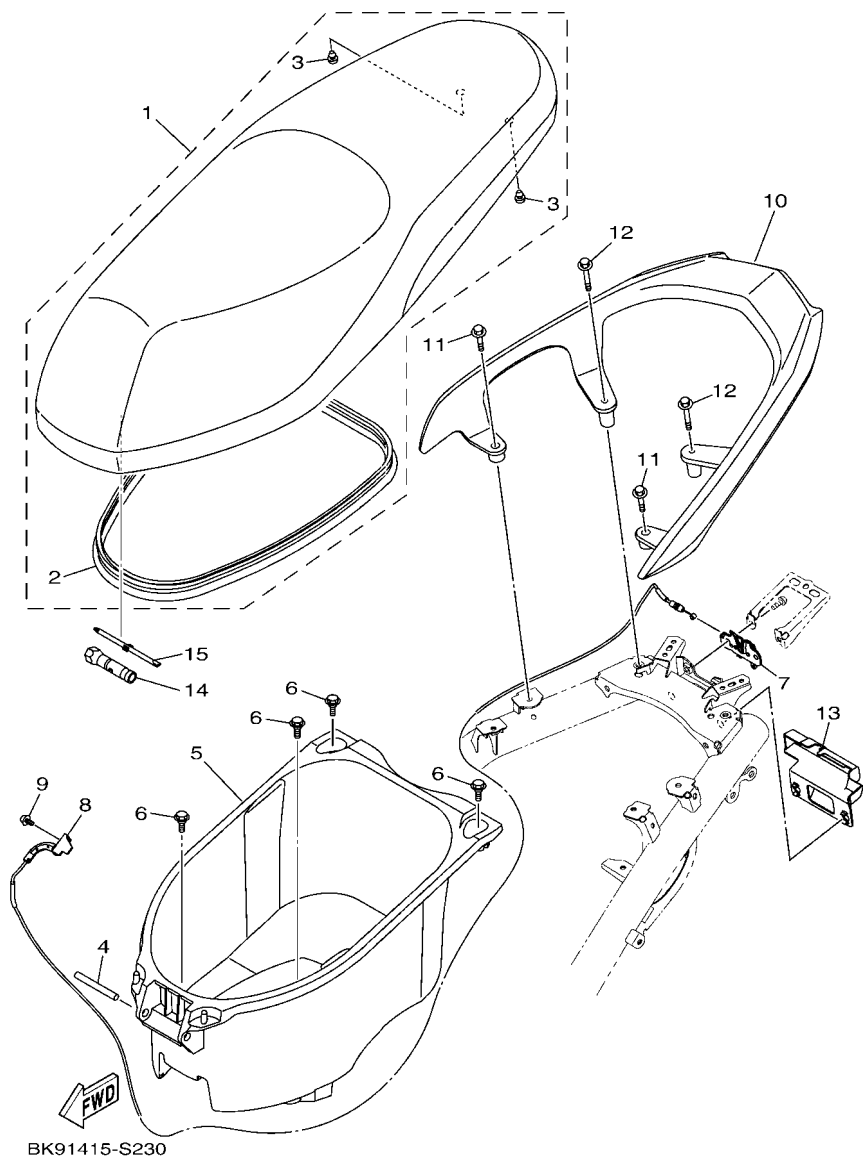

参照 号码	零件号码 PART NO.	零件名称 DESCRIPTION	BK91	BK92	备注 REMARKS
1	BK9-F4730-00	双人座垫组合 DOUBLE SEAT ASSY	1	1	A, B, F (BK92) . G, H, J 车用 FOR A ,B,F(BK92),G,H,J C, D, E 车用 FOR C,D,E F (BK91) 车用 FOR F(BK91)
	BK9-F4730-10	双人座垫组合 DOUBLE SEAT ASSY	1	1	
	BK9-F4730-20	双人座垫组合 DOUBLE SEAT ASSY	1		
2	BK9-F475M-00	. 密封圈 .SEAL	1	1	
3	BK9-F4741-00	. 缓冲座 .PAD, SEAT	2	2	
4	BK9-F472T-00	座位装配销 PIN, SEAT FITTING	1	1	
5	BK9-F473R-00	箱1 BOX 1	1	1	
6	90109-06202	螺栓 BOLT	4	4	
7	BE8-F4780-00	座位锁装置组合 SEAT LOCK ASSY	1	1	
8	BE8-F478E-00	车座锁钢索 CABLE, SEAT LOCK	1	1	
9	97602-05212	带垫圈大柱头螺钉 SCREW, PAN HEAD WITH WASHER	1	1	
10	BK9-F4773-00-P0	后货架组合 HANDLE, SEAT	1	1	A 车用 FOR A B 车用 FOR B C, F (BK92) . H 车用 FOR C,F(BK92),H D, G (BK92) . J 车用 FOR D,G(BK92),J
	BK9-F4773-00-P1	后货架组合 HANDLE, SEAT	1	1	
	BK9-F4773-00-P2	后货架组合 HANDLE, SEAT	1	1	
	BK9-F4773-00-P3	后货架组合 HANDLE, SEAT	1	1	
	BK9-F4773-00-UG	后货架组合 HANDLE, SEAT	1	1	E 车用 FOR E F (BK91) 车用 FOR F(BK91) G (BK91) 车用 FOR G(BK91)
	BK9-F4773-00-8L	后货架组合 HANDLE, SEAT	1		
	BK9-F4773-00-P4	后货架组合 HANDLE, SEAT	1		
11	90119-068C6	带垫螺栓 BOLT, WITH WASHER	2	2	
12	90119-068C7	带垫螺栓 BOLT, WITH WASHER	2	2	
13	BK9-F472T-00	座垫锁盖 COVER, SEAT LOCK	1	1	
14	BE8-F814F-00	火花塞盒 BOX, SPARK PLUG	1	1	
15	5AP-F8152-00	驱动器, 起子 DRIVER	1	1	

FIG. 24 前轮(碟刹)

FRONT WHEEL FOR DISK BRAKE

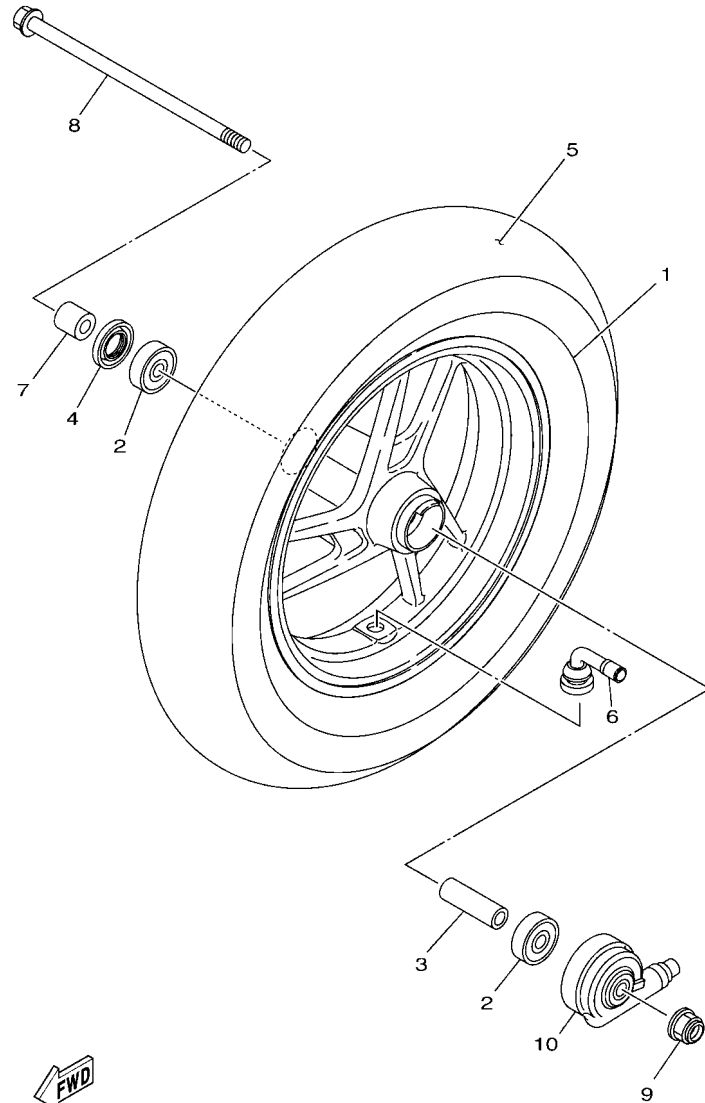

BE81415-S240

参照 号码	零件号码 PART NO.	零件名称 DESCRIPTION	BK91	BK92	备注 REMARKS
1	BE8-F5168-00-35	前压铸轮 CAST WHEEL, FRONT	1		A, B车用 FOR A,B
	BE8-F5168-00-P0	前压铸轮 CAST WHEEL, FRONT	1		C, D, E, G, H, J车用 FOR C,D,E,G,H,J
	BE8-F5168-00-8L	前压铸轮 CAST WHEEL, FRONT	1		F车用 FOR F
2	93306-300YG	轴承 BEARING	2		
3	90387-10841	轴套 COLLAR	1		
4	93106-20813	油封 OIL SEAL	1		
5	94110-10821	轮胎 (100/90-10 C922 56J TL) TIRE (100/90-10 C922 56J TL)	1		CHENG SHIN CHENG SHIN
6	93900-00827	气门嘴 VALVE, RIM	1		
7	90387-10845	轴套 COLLAR	1		
8	BE8-F2141-00	后臂转轴 SHAFT, PIVOT	1		
9	95602-10200	自锁螺母 NUT, S/L FLANGE	1		
10	BK9-F5190-00	齿轮装置组合 GEAR UNIT ASSY	1		

FIG. 25 前轮(鼓刹)

FRONT WHEEL FOR DRUM BRAKE

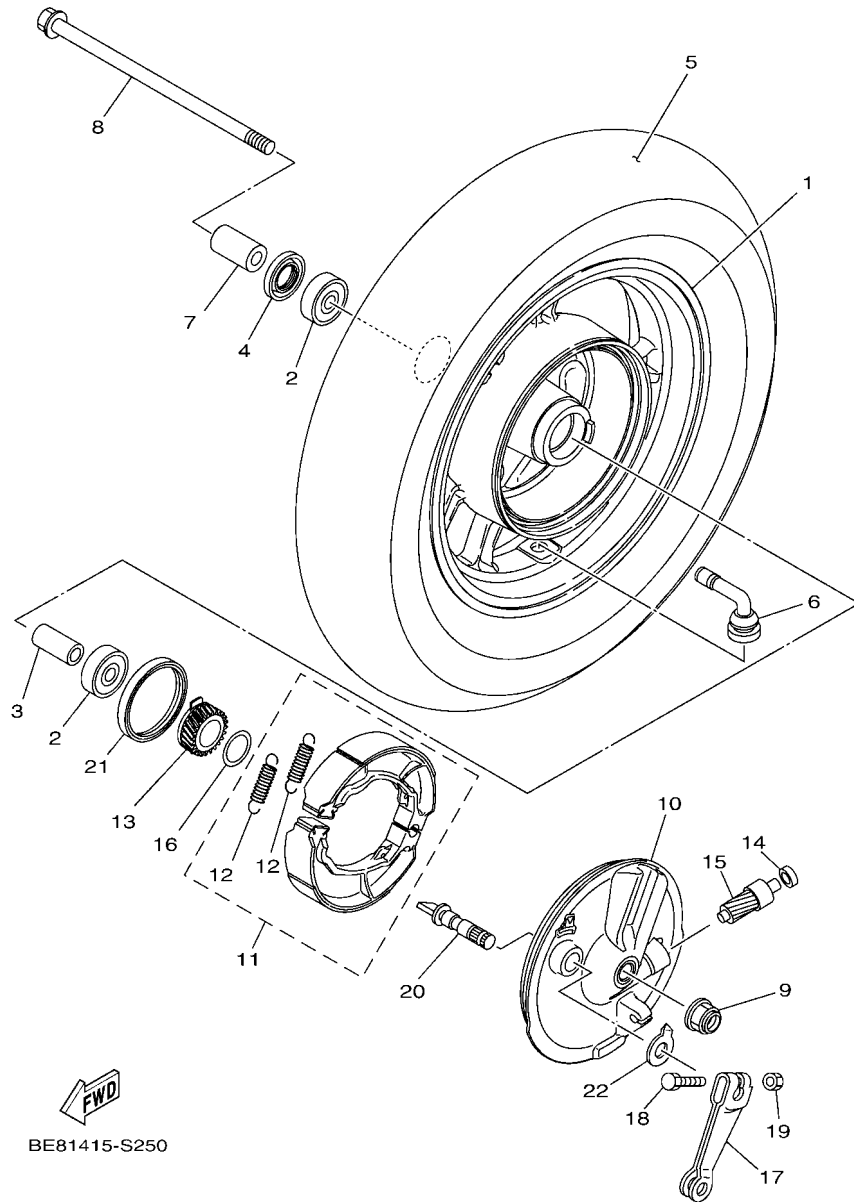

参照 号码	零件号码 PART NO.	零件名称 DESCRIPTION	BK91	BK92	备注 REMARKS
1	BE8-F5168-10-35	前压铸轮 CAST WHEEL, FRONT		1	UR A, B车用 UR FOR A, B
	BE8-F5168-10-P0	前压铸轮 CAST WHEEL, FRONT		1	UR C, D, E, F, G车用 UR FOR C, D, E, F, G
2	93306-300YG	轴承 BEARING		2	
3	90387-10846	轴套 COLLAR		1	
4	93106-20813	油封 OIL SEAL		1	
5	94110-10821	轮胎 (100/90-10 C922 56J TL) TIRE (100/90-10 C922 56J TL)		1	CHENG SHIN CHENG SHIN
6	93900-00827	气门嘴 VALVE, RIM		1	
7	90387-10847	轴套 COLLAR		1	
8	BE8-F2141-00	后臂转轴 SHAFT, PIVOT		1	
9	95602-10200	自锁螺母 NUT, S/L FLANGE		1	
10	BE8-F5121-00-35	前制动盖 PLATE, BRAKE SHOE		1	UR A, B车用 UR FOR A, B
	BE8-F5121-00-P0	前制动盖 PLATE, BRAKE SHOE		1	UR C, D, E, F, G车用 UR FOR C, D, E, F, G
11	BE8-W253A-00	制动蹄块套件 BRAKE SHOE KIT		1	
12	90506-15803	.拉簧 .SPRING, TENSION		2	
13	BK9-F5135-00	主驱动齿轮 GEAR, DRIVE		1	
14	BE8-F5136-00	衬套 BUSH		1	
15	BK9-F5138-00	仪表齿轮 GEAR, METER		1	
16	90201-20823	平垫圈 WASHER, PLATE		1	
17	BE8-F5155-00	制动臂1 LEVER, CAMSHAFT 1		1	
18	90101-06046	螺栓 BOLT		1	
19	95302-06600	螺母 NUT, HEXAGON		1	
20	BE8-F5151-00	凸轮轴 CAMSHAFT		1	
21	93105-47801	油封 OIL SEAL		1	
22	4KL-F513A-01	指示器面板 PLATE, INDICATOR		1	

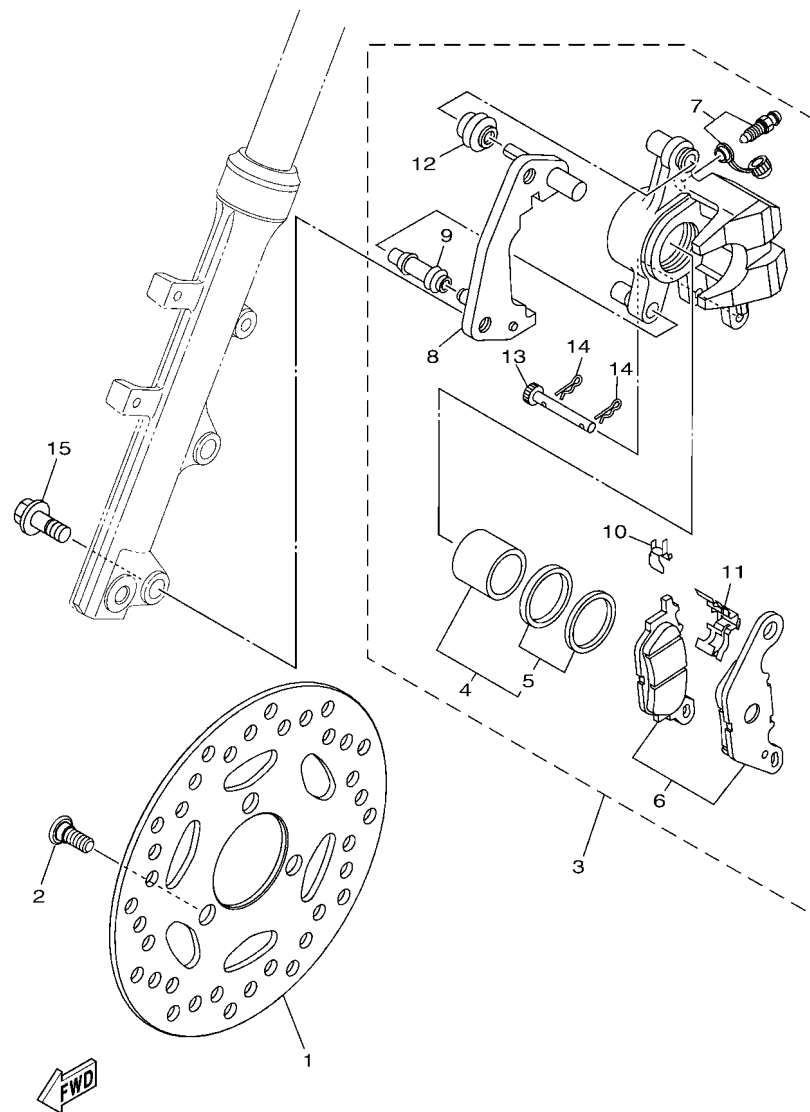

BK91415-S260

FIG. 26 前制动器卡钳

FRONT BRAKE CALIPER

参照 号码	零件号码 PART NO.	零件名称 DESCRIPTION	BK91	BK92	备注 REMARKS
1	BE8-F582U-00	制动盘(右边) DISK, BRAKE (RIGHT)	1		
2	90109-08232	螺栓 BOLT	3		
3	BE8-F580U-10	制动器卡钳组合(右边) CALIPER ASSY (RIGHT)	1		
4	4S5-W0057-00	卡钳活塞组合 PISTON ASSY, CALIPER	1		
5	4S5-W0047-00	卡钳密封套件 CALIPER SEAL KIT	1		
6	4S5-W0045-00	刹车片组合 BRAKE PAD KIT	1		
7	4S5-W0048-01	带孔螺钉套件 BLEED SCREW KIT	1		
8	4S9-F5921-01	固定架 BRACKET, SUPPORT	1		
9	4S5-F5937-00	衬套 BOOT 2	1		
10	4S5-F5939-00	扣片 CLIP, PAD	1		
11	4S5-F5919-00	弹簧 SUPPORT, PAD	1		
12	4S5-F5917-00	防尘套 BOOT, CALIPER	1		
13	4S5-F5924-01	刹车片销 PIN, PAD	1		
14	4S5-F5925-00	卡环 CLIP	2		
15	90105-10831	凸缘螺栓 BOLT, FLANGE	2		

FIG. 27 后轮

REAR WHEEL

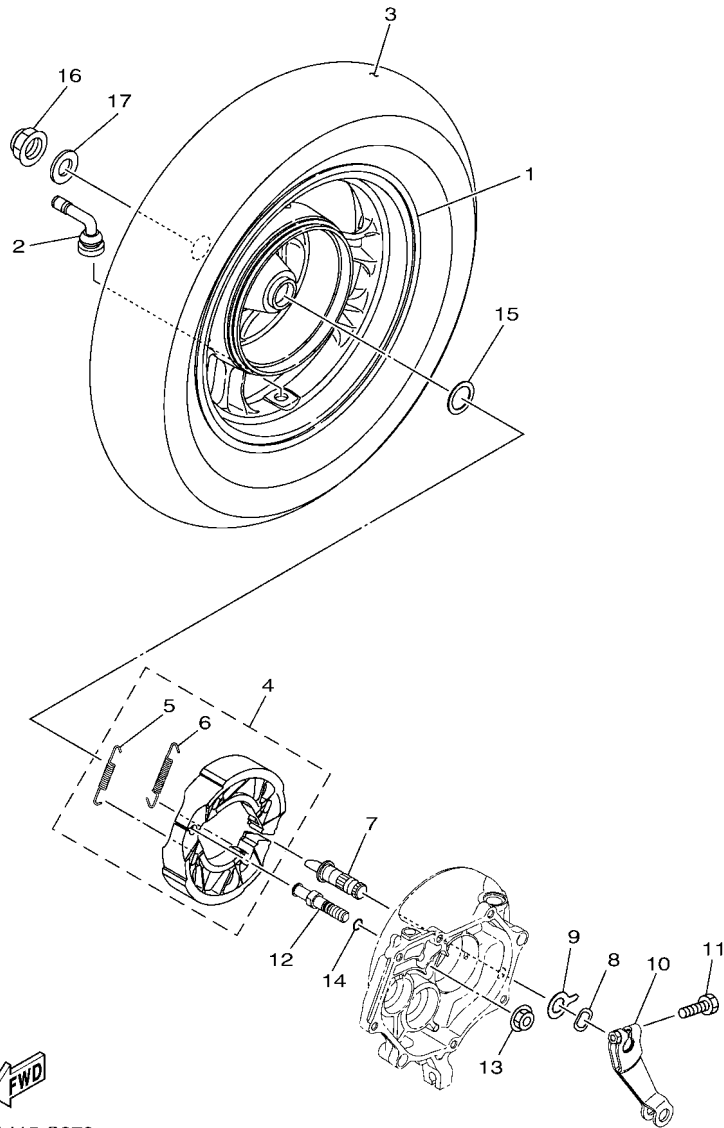

BE81415-S270

参照 号码	零件号码 PART NO.	零件名称 DESCRIPTION	BK91	BK92	备注 REMARKS
1	BE8-F5338-00-35	后压铸轮 CAST WHEEL, REAR	1	1	A, B车用 FOR A,B C, D, E, F (BK92), G, H车用 FOR C, D, E, F (BK92), G, H F (BK91) 车用 FOR F (BK91)
	BE8-F5338-00-P0	后压铸轮 CAST WHEEL, REAR	1	1	
	BE8-F5338-00-8L	后压铸轮 CAST WHEEL, REAR	1		
2	93900-00827	气门嘴 VALVE, RIM	1	1	
3	94110-10822	轮胎 (100/90-10 C940 56J TL) TIRE (100/90-10 C940 56J TL)	1	1	CHENG SHIN CHENG SHIN
4	BE8-Y2530-00	后制动蹄块组合 REAR BRAKE SHOE ASSY	1	1	
5	90506-15802	.拉簧 .SPRING, TENSION	1	1	
6	90506-12801	.拉簧 .SPRING, TENSION	1	1	
7	BE8-F5351-00	凸轮轴 CAMSHAFT	1	1	
8	90206-14802	波形垫圈 WASHER, WAVE	1	1	
9	BE8-F533A-00	指示片 PLATE, INDICATOR	1	1	
10	BE8-F5355-00	制动臂 1 LEVER, CAMSHAFT	1	1	
11	90101-06046	螺栓 BOLT	1	1	
12	BE8-F5326-00	枢轴 PIN, PIVOT	1	1	
13	95702-10500	螺母 NUT, FLANGE	1	1	
14	93210-07890	O型环 O-RING	1	1	
15	90201-220J8	平垫圈 WASHER, PLATE	1	1	
16	90185-16800	自锁螺母 NUT, SELF-LOCKING	1	1	
17	90201-16811	平垫圈 WASHER, PLATE	1	1	

FIG. 28 操纵手柄·钢索(碟刹)

STEERING CABLE FOR DISK BRAKE

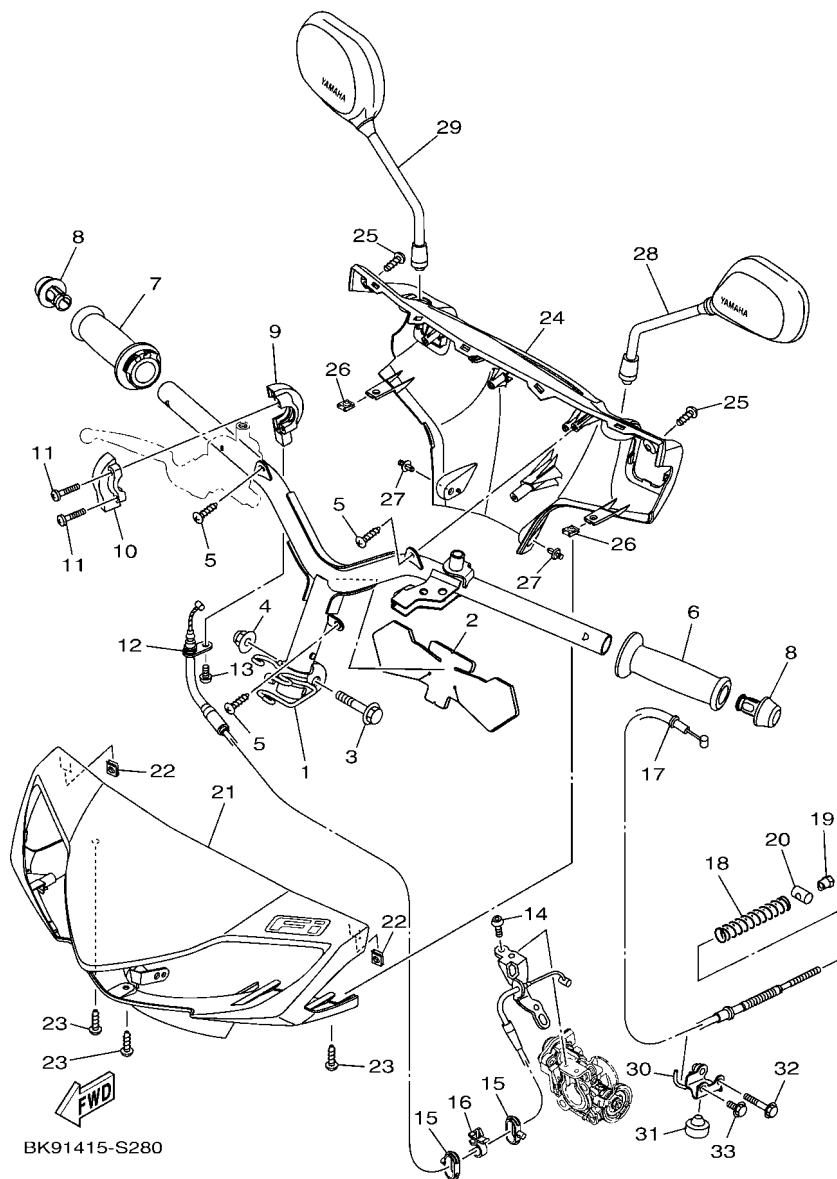

BK91415-S280

参照 号码	零件号码 PART NO.	零件名称 DESCRIPTION	BK91	BK92	备注 REMARKS
1	BK9-F6110-00	手把组件 HANDLE COMP.	1		
2	BK9-F6113-00	减震垫 DAMPER	1		
3	90105-10295	凸缘螺栓 BOLT, FLANGE	1		
4	90185-10011	自锁螺母 NUT, SELF-LOCKING	1		
5	97702-50016	自攻螺钉 SCREW, TAPPING	3		
6	BE8-F6241-00	握把(左边) GRIP	1		A, B, F, G, H, J车用 FOR A,B,F,G,H,J
	BK9-F6241-00	握把(左边) GRIP	1		C, D, E车用 FOR C,D,E
7	BE8-F6240-00	握把(右边) GRIP ASSY	1		A, B, F, G, H, J车用 FOR A,B,F,G,H,J
	BK9-F6240-00	握把(右边) GRIP ASSY	1		C, D, E车用 FOR C,D,E
8	BE8-F6246-00	握柄端 END, GRIP	2		
9	BE8-F6281-00	握把上侧盖 CAP, GRIP UPPER	1		
10	BE8-F6282-00	握把下侧盖 CAP, GRIP UNDER	1		
11	98502-05025	十字螺钉 SCREW, PAN HEAD	2		
12	BK9-F6311-00	节气门拉索1 CABLE, THROTTLE 1	1		
13	92012-05016	螺钉 BOLT, BUTTON HEAD	1		
14	92012-05010	螺钉 BOLT, BUTTON HEAD	2		
15	90464-10803	线夹 CLAMP	2		
16	90464-09805	线夹 CLAMP	1		
17	BK9-F6351-00	制动器钢索 CABLE, BRAKE	1		
18	90501-16003	压簧 SPRING, COMPRESSION	1		
19	90179-06835	螺母 NUT	1		
20	90249-12806	销 PIN	1		
21	BK9-W2614-00-P0	手把盖总成 PROTECTOR, HANDLEBAR	1		UR A车用 UR FOR A
	BK9-W2614-00-P1	手把盖总成 PROTECTOR, HANDLEBAR	1		UR B车用 UR FOR B
	BK9-W2614-00-P2	手把盖总成 PROTECTOR, HANDLEBAR	1		UR C, H车用 UR FOR C,H
	BK9-W2614-00-P3	手把盖总成 PROTECTOR, HANDLEBAR	1		UR D, J车用 UR FOR D,J
	BK9-W2614-00-UG	手把盖总成 PROTECTOR, HANDLEBAR	1		UR E车用 UR FOR E

FIG. 28 操纵手柄·钢索(碟刹)

STEERING CABLE FOR DISK BRAKE

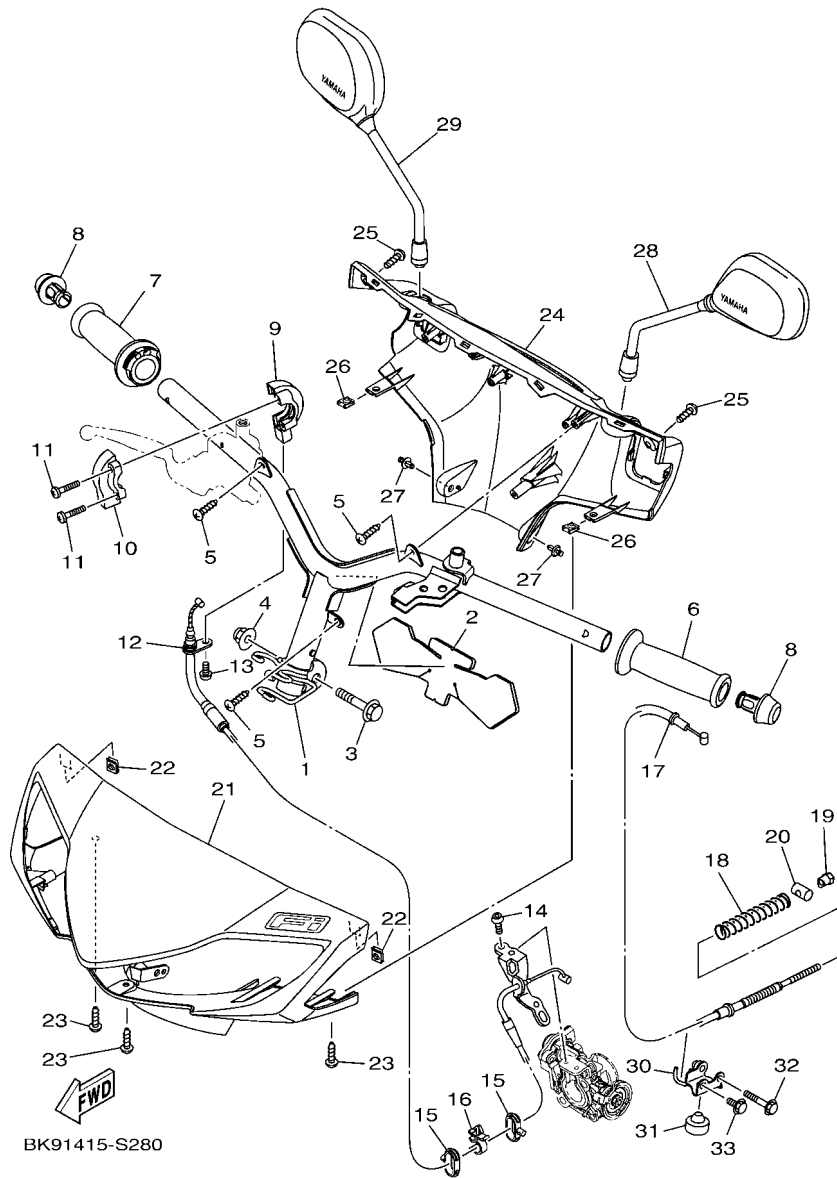

参照 号码	零件号码 PART NO.	零件名称 DESCRIPTION	BK91	BK92	备注 REMARKS
21	BK9-W2614-00-P4	手把盖总成 PROTECTOR, HANDLEBAR	1		UR F车用 UR FOR F
	BK9-W2614-00-P5	手把盖总成 PROTECTOR, HANDLEBAR	1		UR G车用 UR FOR G
22	90183-05818	弹性螺母 NUT, SPRING	2		
23	97702-50012	自攻螺钉 SCREW, TAPPING	3		
24	BK9-F6145-00	手把杆上侧盖2 COVER, HANDLE UPPER 2	1		A, B, F, G, H, J车用 FOR A,B,F,G,H,J
	BK9-F6145-10	手把杆上侧盖2 COVER, HANDLE UPPER 2	1		C, D, E车用 FOR C,D,E
25	90160-05803	圆形自攻螺钉 SCREW, ROUND TAPPING	2		
26	90183-05818	弹性螺母 NUT, SPRING	2		
27	90269-06809	铆钉 RIVET	2		
28	BE8-F6280-00	后视镜组合(左边) REAR VIEW MIRROR ASSY (LEFT)	1		
29	BE8-F6290-00	后视镜组合(右边) REAR VIEW MIRROR ASSY (RIGHT)	1		
30	BE8-F637G-00	钢索支架 HOLDER, WIRE	1		
31	BE8-F1439-00	主停车架限位板 STOPPER, MAIN STAND	1		
32	95022-06035	凸缘螺栓 BOLT, FLANGE	1		
33	95022-06014	凸缘螺栓 BOLT, FLANGE	1		

FIG. 29 操纵手柄·钢索(鼓刹)

STEERING CABLE FOR DRUM BRAKE

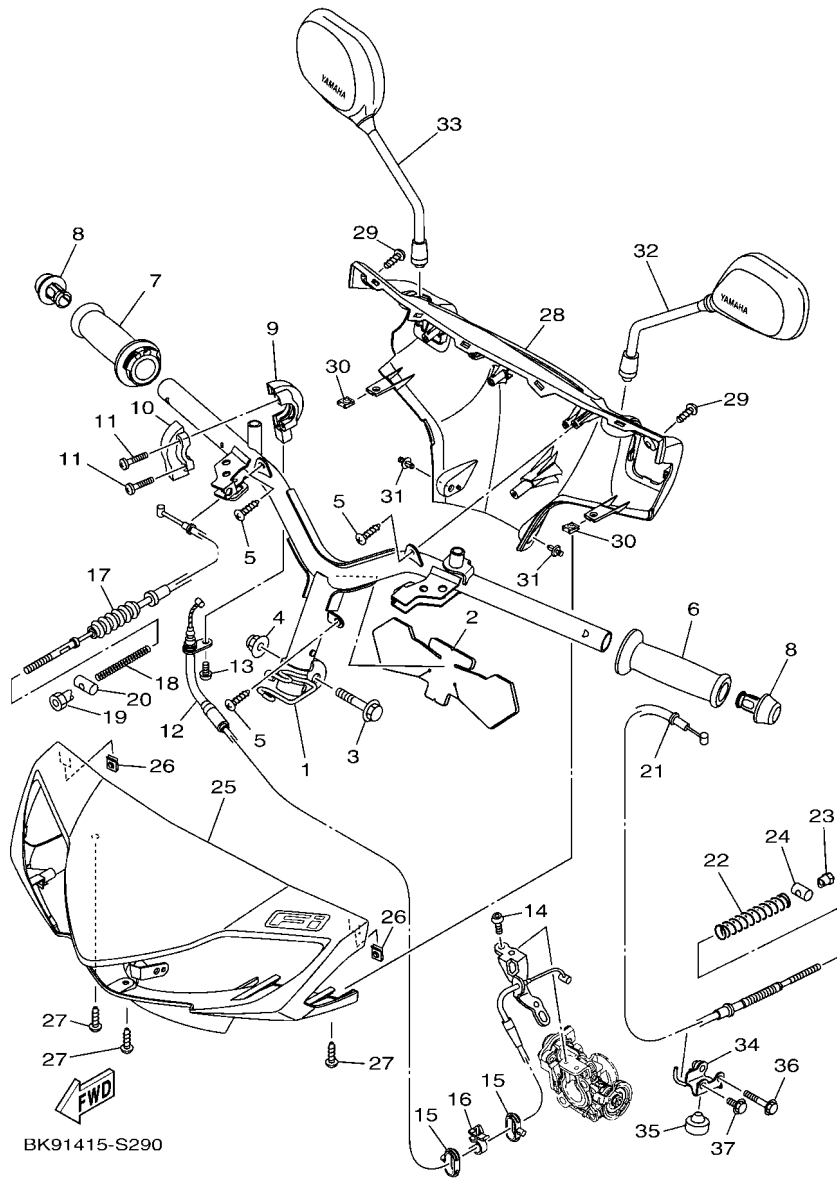

BK91415-S290

参照 号码	零件号码 PART NO.	零件名称 DESCRIPTION	BK91	BK92	备注 REMARKS
1	BK9-F6110-10	手柄组件 HANDLE COMP.		1	
2	BK9-F6113-00	减震垫 DAMPER		1	
3	90105-10295	凸缘螺栓 BOLT, FLANGE		1	
4	90185-10011	自锁螺母 NUT, SELF-LOCKING		1	
5	97702-50016	自攻螺钉 SCREW, TAPPING		3	
6	BE8-F6241-00	握把(左边) GRIP		1	UR A, B, F, G车用 UR FOR A,B,F,G
	BK9-F6241-00	握把(左边) GRIP		1	UR C, D, E车用 UR FOR C,D,E
7	BE8-F6240-00	握把(右边) GRIP ASSY		1	UR A, B, F, G车用 UR FOR A,B,F,G
	BK9-F6240-00	握把(右边) GRIP ASSY		1	UR C, D, E车用 UR FOR C,D,E
8	BE8-F6246-00	握柄端 END, GRIP		2	
9	BE8-F6281-00	握把上侧盖 CAP, GRIP UPPER		1	
10	BE8-F6282-00	握把下侧盖 CAP, GRIP UNDER		1	
11	98502-05025	十字螺钉 SCREW, PAN HEAD		2	
12	BK9-F6311-00	节气门拉索1 CABLE, THROTTLE 1		1	
13	92012-05016	螺钉 BOLT, BUTTON HEAD		1	
14	92012-05010	螺钉 BOLT, BUTTON HEAD		2	
15	90464-10803	线夹 CLAMP		2	
16	90464-09805	线夹 CLAMP		1	
17	BK9-F6341-00	制动拉索1 WIRE, BRAKE 1		1	
18	90501-10814	压簧 SPRING, COMPRESSION		1	
19	90179-06835	螺母 NUT		1	
20	90249-12806	销 PIN		1	
21	BK9-F6351-00	制动器钢索 CABLE, BRAKE		1	
22	90501-16003	压簧 SPRING, COMPRESSION		1	
23	90179-06835	螺母 NUT		1	
24	90249-12806	销 PIN		1	
25	BK9-W2614-00-P0	手柄盖总成 PROTECTOR, HANDLEBAR		1	UR A车用 UR FOR A

FIG. 29 操纵手柄·钢索(鼓刹)

STEERING CABLE FOR DRUM BRAKE

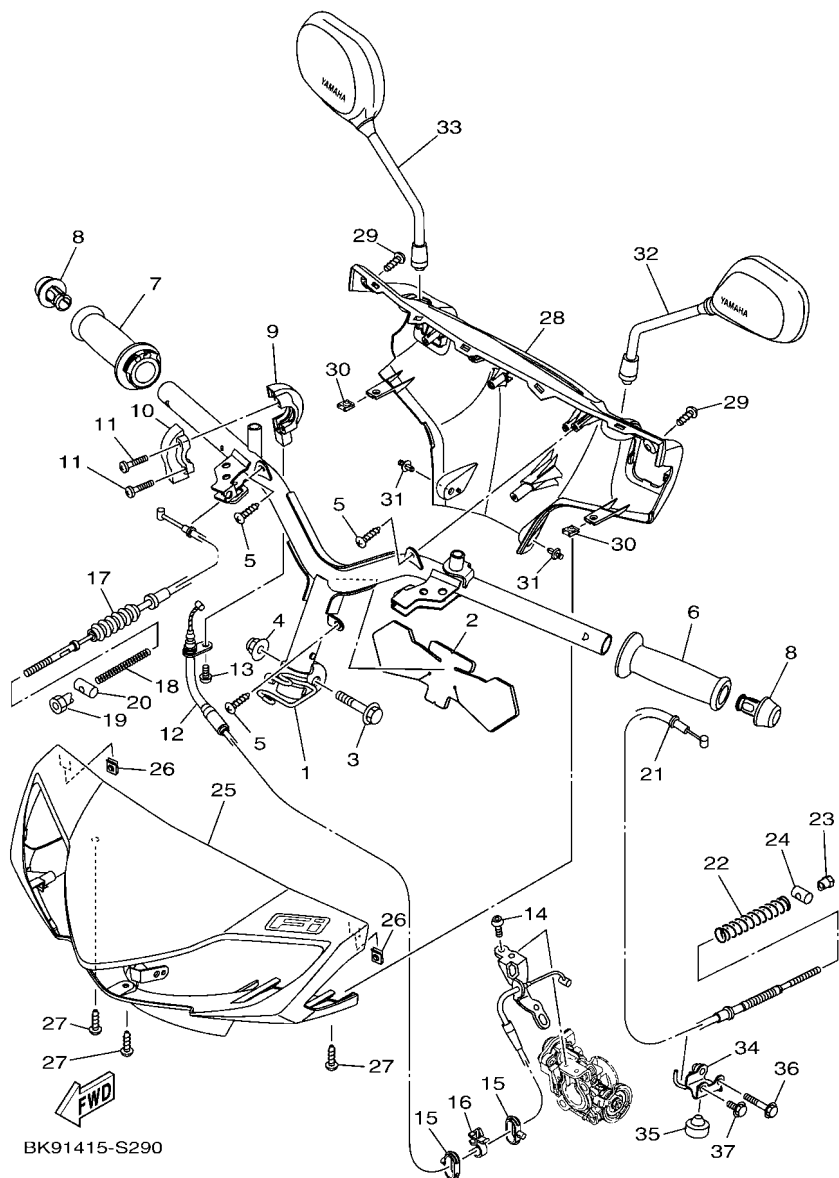

参照 号码	零件号码 PART NO.	零件名称 DESCRIPTION	BK91	BK92	备注 REMARKS
25	BK9-W2614-00-P1	手把盖总成 PROTECTOR, HANDLEBAR		1	UR B车用 UR FOR B
	BK9-W2614-00-P2	手把盖总成 PROTECTOR, HANDLEBAR		1	UR C, F车用 UR FOR C, F
	BK9-W2614-00-P3	手把盖总成 PROTECTOR, HANDLEBAR		1	UR D, G车用 UR FOR D, G
	BK9-W2614-00-UG	手把盖总成 PROTECTOR, HANDLEBAR		1	UR E车用 UR FOR E
26	90183-05818	弹性螺母 NUT, SPRING		2	
27	97702-50012	自攻螺钉 SCREW, TAPPING		3	
28	BK9-F6145-00	手把杆上侧盖2 COVER, HANDLE UPPER 2		1	UR A, B, F, G车用 UR FOR A, B, F, G
	BK9-F6145-10	手把杆上侧盖2 COVER, HANDLE UPPER 2		1	UR C, D, E车用 UR FOR C, D, E
29	90160-05803	圆形自攻螺钉 SCREW, ROUND TAPPING		2	
30	90183-05818	弹性螺母 NUT, SPRING		2	
31	90269-06809	铆钉 RIVET		2	
32	BE8-F6280-00	后视镜组合(左边) REAR VIEW MIRROR ASSY (LEFT)		1	
33	BE8-F6290-00	后视镜组合(右边) REAR VIEW MIRROR ASSY (RIGHT)		1	
34	BE8-F637G-00	钢索支架 HOLDER, WIRE		1	
35	BE8-F1439-00	主停车架限位板 STOPPER, MAIN STAND		1	
36	95022-06035	凸缘螺栓 BOLT, FLANGE		1	
37	95022-06014	凸缘螺栓 BOLT, FLANGE		1	

FIG. 30 前主缸

FRONT MASTER CYLINDER

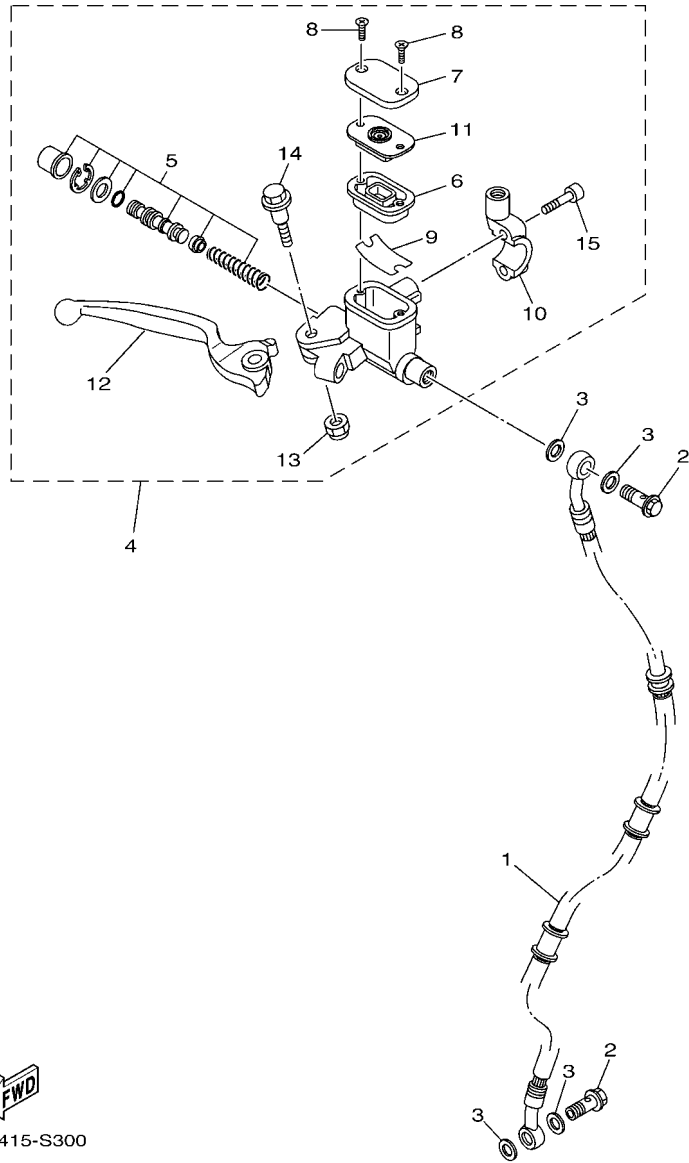

参照 号码	零件号码 PART NO.	零件名称 DESCRIPTION	BK91	BK92	备注 REMARKS
1	BK9-F5872-00	制动软管1 HOSE, BRAKE 1	1		
2	90401-10823	螺栓 BOLT, UNION	2		
3	90201-10118	平垫圈 WASHER, PLATE	4		
4	4S9-F583T-01	前主缸组合 MASTER CYLINDER ASSY	1		
5	4S9-W0041-01	前主缸套件 CYLINDER KIT, MASTER	1		
6	4S9-F5854-00	油箱隔膜 DIAPHRAGM, RESERVOIR	1		
7	4S9-F5852-00	油杯盖 CAP, RESERVOIR	1		
8	4KL-F589H-01	螺钉 SCREW	2		
9	4KL-F5896-00	储油箱面板 PLATE, RESERVOIR	1		
10	4S9-F5867-00	主缸托架 BRACKET, MASTER CYLINDER	1		
11	4S9-F5855-00	隔膜衬套 BUSH, DIAPHRAGM	1		
12	4S9-H3922-00	手柄2 LEVER 2	1		
13	3D9-F586F-01	手柄螺帽 NUT, U	1		
14	3D9-F589F-01	手柄螺栓 BOLT, LEVER	1		
15	91312-06025	螺栓 BOLT, HEXAGON SOCKET HEAD	2		



BE81415-S300

FIG. 31 搁脚·支架

STAND & FOOTREST

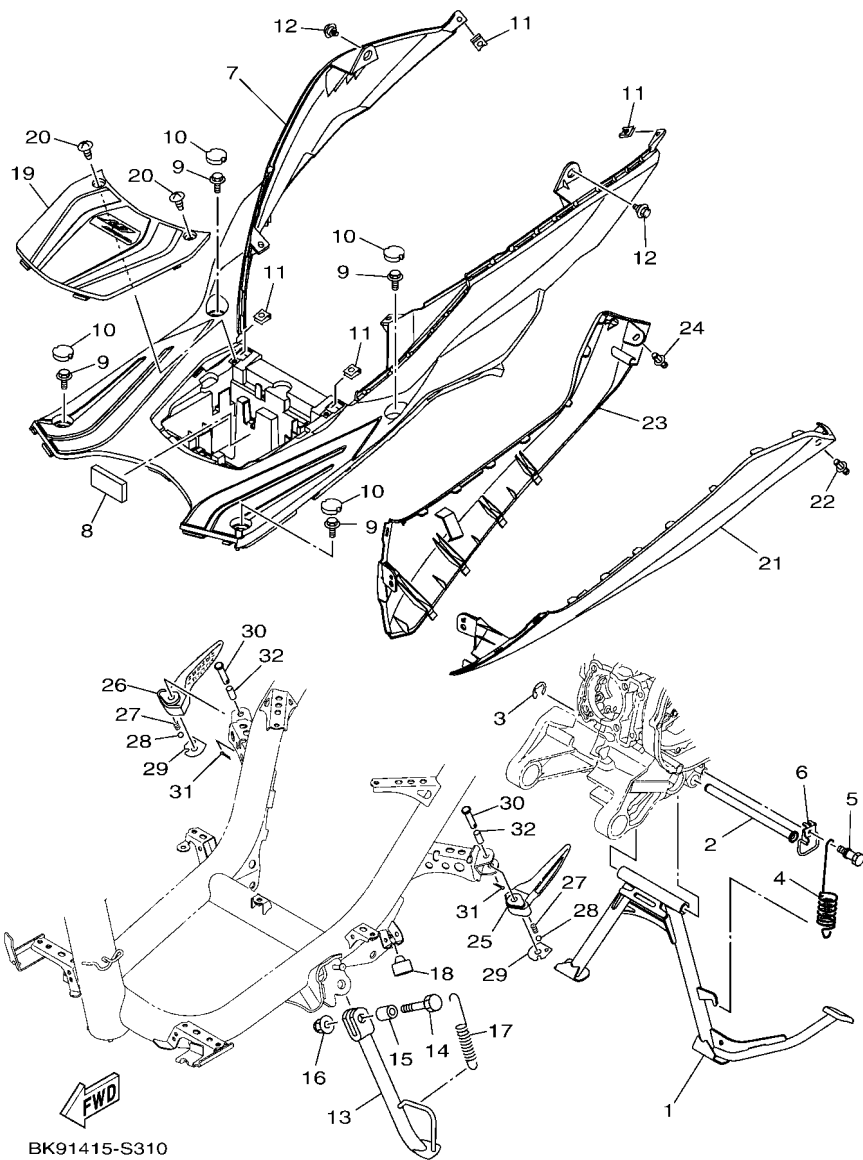

BK91415-S310

参照 号码	零件号码 PART NO.	零件名称 DESCRIPTION	BK91	BK92	备注 REMARKS
1	BK9-F7111-00	主支承 STAND, MAIN	1	1	
2	BK9-F7112-00	主支承轴 SHAFT, MAIN STAND	1	1	
3	99002-09600	卡环 CIRCLIP	1	1	
4	90506-32812	拉簧 SPRING, TENSION	1	1	
5	BE8-F7254-00	挂钩 HOOK	1	1	
6	BK9-F7267-00	导线 GUIDE, WIRE	1	1	
7	BK9-F7481-00	搁脚踏板 BOARD, FOOTREST	1	1	A, B, F, G, H, J车用 FOR A,B,F,G,H,J
	BK9-F7481-10	搁脚踏板 BOARD, FOOTREST	1	1	C, D, E车用 FOR C,D,E
8	90520-08813	面板减震器 DAMPER, PLATE	1	1	
9	90119-06869	带垫螺栓 BOLT, WITH WASHER	4	4	
10	BK9-F7475-00	盖1 CAP 1	4	4	A, B, F, G, H, J车用 FOR A,B,F,G,H,J
	BK9-F7475-10	盖1 CAP 1	4	4	C, D, E车用 FOR C,D,E
11	90183-05818	弹性螺母 NUT, SPRING	2	2	
12	90109-06202	螺栓 BOLT	2	2	
13	BK9-F7311-00	侧支承 STAND, SIDE	1	1	
14	90101-08829	螺栓 BOLT	1	1	
15	90387-08820	轴套 COLLAR	1	1	
16	95602-08200	自锁螺母 NUT, U FLANGE	1	1	
17	90506-20829	拉簧 SPRING, TENSION	1	1	
18	BK9-F6257-00	限位板 STOPPER	1	1	
19	BK9-H2129-00	蓄电池盖 COVER, BATTERY	1	1	A, B, F, G, H, J车用 FOR A,B,F,G,H,J
	BK9-H2129-10	蓄电池盖 COVER, BATTERY	1	1	C, D, E车用 FOR C,D,E
20	97707-50012	自攻螺钉 SCREW, TRUSS HEAD TAPPING	2	2	
21	BK9-F171L-00-P0	侧盖嵌条1 MOLE, SIDE COVER 1	1	1	A车用 FOR A
	BK9-F171L-00-P1	侧盖嵌条1 MOLE, SIDE COVER 1	1	1	B车用 FOR B
	BK9-F171L-00-P2	侧盖嵌条1 MOLE, SIDE COVER 1	1	1	C, F (BK92), H车用 FOR C,F(BK92),H
	BK9-F171L-00-P3	侧盖嵌条1 MOLE, SIDE COVER 1	1	1	D, G (BK92), J车用 FOR D,G(BK92),J

FIG. 31 搁脚·支架

STAND & FOOTREST

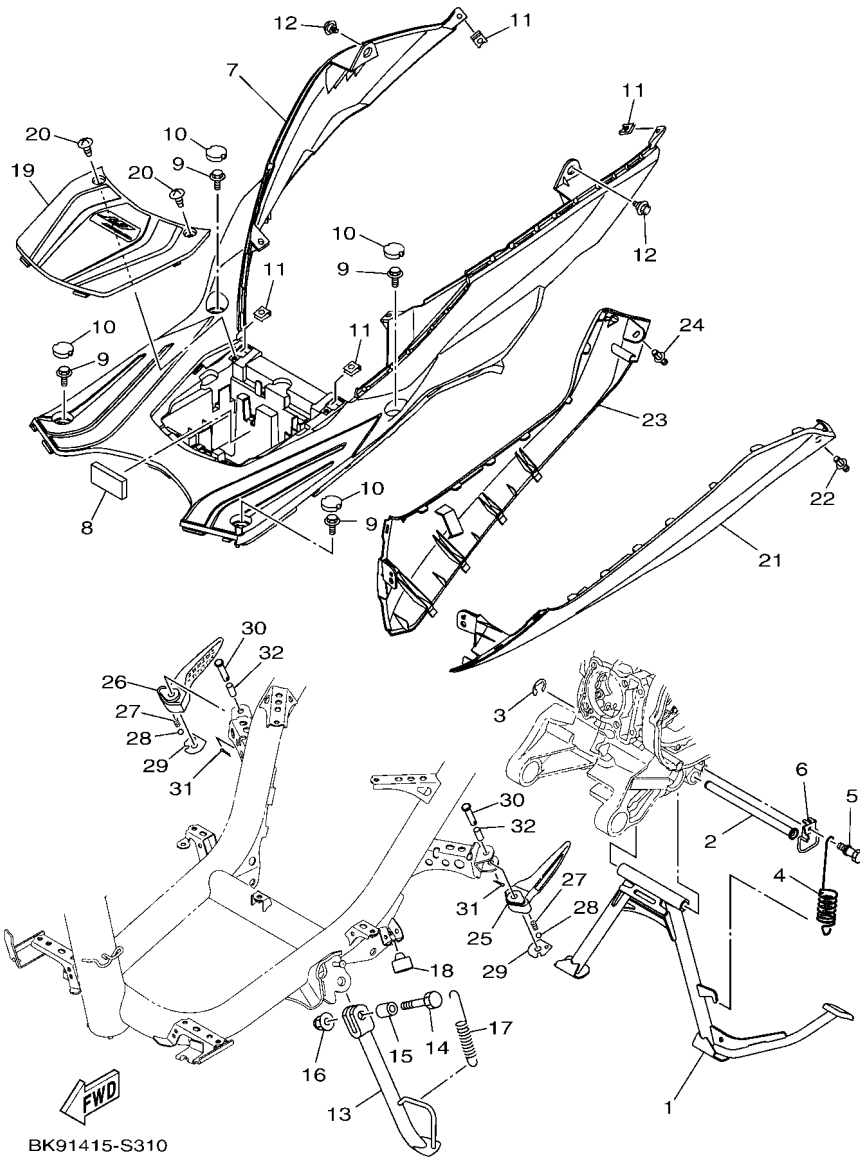

BK91415-S310

参照 号码	零件号码 PART NO.	零件名称 DESCRIPTION	BK91	BK92	备注 REMARKS
21	BK9-F171L-00-UG	侧盖嵌条1 MOLE, SIDE COVER 1	1	1	E车用 FOR E
	BK9-F171L-00-P4	侧盖嵌条1 MOLE, SIDE COVER 1	1		F (BK91) 车用 FOR F(BK91)
	BK9-F171L-00-P5	侧盖嵌条1 MOLE, SIDE COVER 1	1		G (BK91) 车用 FOR G(BK91)
22	90269-06809	铆钉 RIVET	1	1	
23	BK9-F171M-00-P0	侧盖嵌条2 MOLE, SIDE COVER 2	1	1	A车用 FOR A
	BK9-F171M-00-P1	侧盖嵌条2 MOLE, SIDE COVER 2	1	1	B车用 FOR B
	BK9-F171M-00-P2	侧盖嵌条2 MOLE, SIDE COVER 2	1	1	C, F (BK92), H车用 FOR C,F(BK92),H
	BK9-F171M-00-P3	侧盖嵌条2 MOLE, SIDE COVER 2	1	1	D, G (BK92), J车用 FOR D,G(BK92),J
	BK9-F171M-00-UG	侧盖嵌条2 MOLE, SIDE COVER 2	1	1	E车用 FOR E
	BK9-F171M-00-P4	侧盖嵌条2 MOLE, SIDE COVER 2	1		F (BK91) 车用 FOR F(BK91)
	BK9-F171M-00-P5	侧盖嵌条2 MOLE, SIDE COVER 2	1		G (BK91) 车用 FOR G(BK91)
24	90269-06809	铆钉 RIVET	1	1	
25	BK9-F7431-00	后搁脚板1 FOOTREST, REAR 1	1	1	
26	BK9-F7441-00	后搁脚板2 FOOTREST, REAR 2	1	1	
27	90501-12743	压簧 SPRING, COMPRESSION	2	2	
28	93501-04805	滚珠 BALL	2	2	
29	BK9-F7437-00	特制垫片 WASHER, SPECIAL	2	2	
30	91702-06038	叉杆销 PIN, CLEVIS	2	2	
31	91402-20012	开口销 PIN, COTTER	2	2	
32	90387-064H8	轴套 COLLAR	2	2	

FIG. 32 护腿

LEG SHIELD

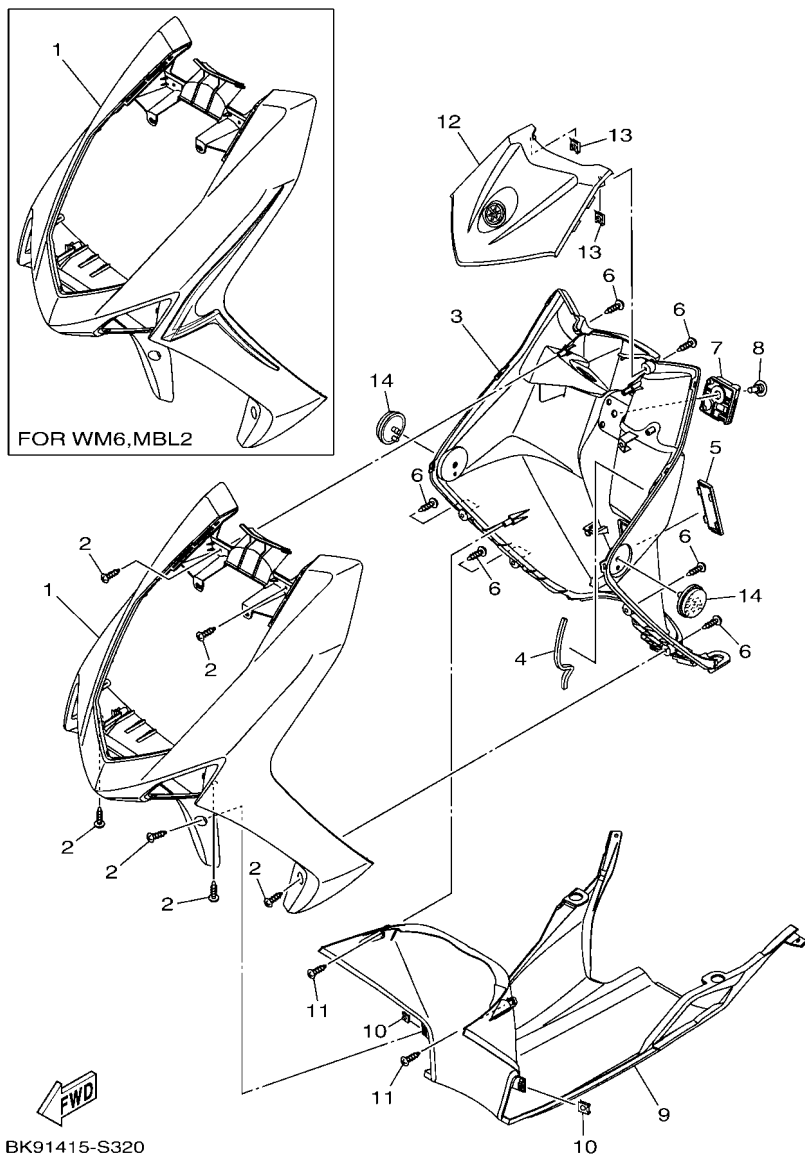

BK91415-S320

参照 号码	零件号 PART NO.	零件名称 DESCRIPTION	BK91	BK92	备注 REMARKS
1	BK9-F8311-00-P0	护腿板1 LEG SHIELD 1	1	1	A车用 FOR A
	BK9-F8311-00-P1	护腿板1 LEG SHIELD 1	1	1	B车用 FOR B
	BK9-F8311-00-P2	护腿板1 LEG SHIELD 1	1	1	C, F (BK92), H车用 FOR C, F (BK92), H
	BK9-F8311-00-P3	护腿板1 LEG SHIELD 1	1	1	D, G (BK92), J车用 FOR D, G (BK92), J
	BK9-F8311-00-UG	护腿板1 LEG SHIELD 1	1	1	E车用 FOR E
	BK9-W2831-00-P4	护腿板1 LEG SHIELD 1	1		F (BK91) 车用 FOR F (BK91)
	BK9-W2831-00-P5	护腿板1 LEG SHIELD 1	1		G (BK91) 车用 FOR G (BK91)
2	97702-50016	自攻螺钉 SCREW, TAPPING	6	6	
3	BK9-W2830-00	护腿罩板总成 LEG SHIELD SET	1	1	A, B, F, G, H, J车用 FOR A, B, F, G, H, J
	BK9-W2830-10	护腿罩板总成 LEG SHIELD SET	1	1	C, D, E车用 FOR C, D, E
4	90520-10825	面板减震器 DAMPER, PLATE	1	1	
5	BK9-F8349-00	盖 CAP	1	1	A, B, F, G, H, J车用 FOR A, B, F, G, H, J
	BK9-F8349-10	盖 CAP	1	1	C, D, E车用 FOR C, D, E
6	97707-50016	自攻螺钉 SCREW, TRUSS HEAD TAPPING	6	6	
7	BE8-F8379-00	挂钩 HOOK	1	1	A, B, F, G, H, J车用 FOR A, B, F, G, H, J
	BK9-F8379-00	挂钩 HOOK	1	1	C, D, E车用 FOR C, D, E
8	90109-06265	螺栓 BOLT	1	1	
9	BK9-F1552-00	内防护板 FENDER, INNER	1	1	
10	90183-05818	弹性螺母 NUT, SPRING	2	2	
11	97702-50016	自攻螺钉 SCREW, TAPPING	2	2	
12	BK9-W2834-00-P0	嵌条1 MOLE 1	1	1	UR A, B, C, F, H车用 UR FOR A, B, C, F, H
	BK9-W2834-00-P1	嵌条1 MOLE 1	1	1	UR D, G, J车用 UR FOR D, G, J
	BK9-W2834-00-UG	嵌条1 MOLE 1	1	1	UR E车用 UR FOR E
	BK9-W2834-00-P2	嵌条1 MOLE 1	1		UR F车用 UR FOR F
	BK9-W2834-00-P3	嵌条1 MOLE 1	1		UR G车用 UR FOR G
13	90183-05818	弹性螺母 NUT, SPRING	2	2	
14	4S5-H5131-00	后反射镜1 REFLECTOR, REAR 1	2	2	

FIG. 34 起动电机

STARTING MOTOR

参照 号码	零件号码 PART NO.	零件名称 DESCRIPTION	BK91	BK92	备注 REMARKS
1	BE8-H1890-00	起动电机 MOTOR ASSY	1	1	
2	BE8-H1801-00	.碳刷组件 .BRUSH SET	1	1	
3	4S9-H1834-00	.环 .RING	1	1	
4	1JD-H1828-00	.组合螺钉 .SCREW SET	2	2	
5	91312-06020	螺栓 BOLT	2	2	
6	93210-29811	O型环 O-RING	1	1	
7	98902-05008	十字槽盘头螺钉 SCREW, BIND	1	1	

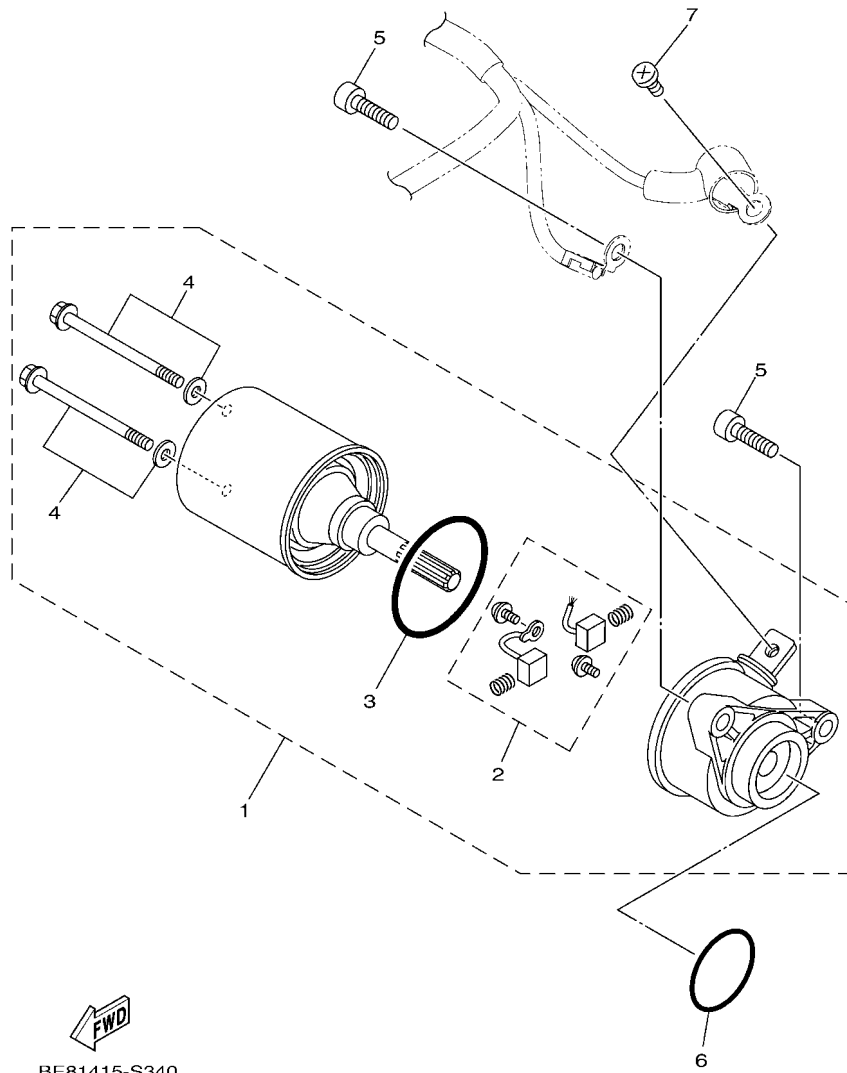

BE81415-S340

FIG. 35 转向灯

FLASHER LIGHT

参照 号码	零件号码 PART NO.	零件名称 DESCRIPTION	BK91	BK92	备注 REMARKS
1	BK9-H3301-00	前闪烁器组合1 FRONT FLASHER LIGHT ASSY 1	1	1	
2	4S5-H3311-00	.转向灯灯泡 .BULB, FLASHER (12V-10W)	2	2	
3	BK9-H331E-00	.缆索组合 .CORD ASSY	1	1	
4	97702-50016	自攻螺钉 SCREW, TAPPING	5	5	
5	90183-05818	弹性螺母 NUT, SPRING	1	1	

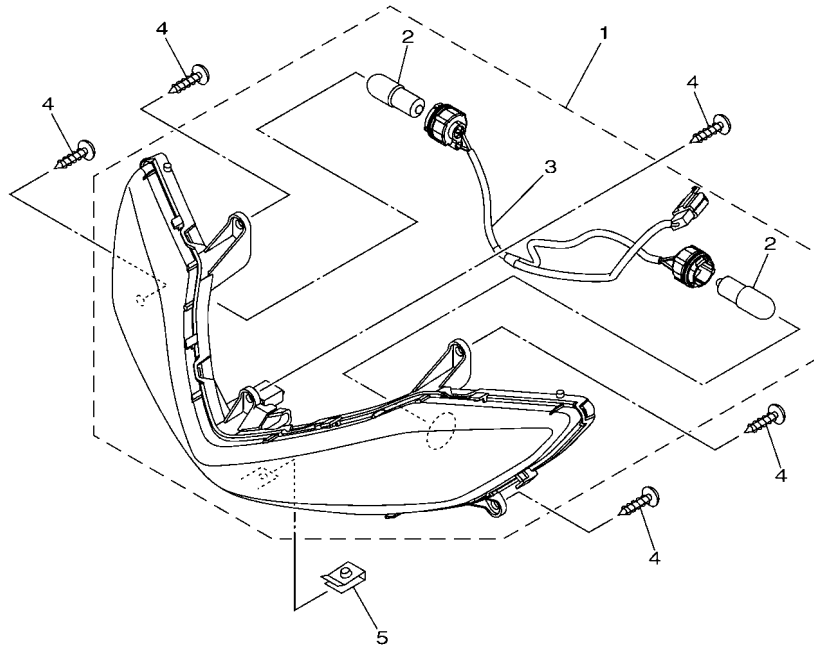

 BK91415-S350

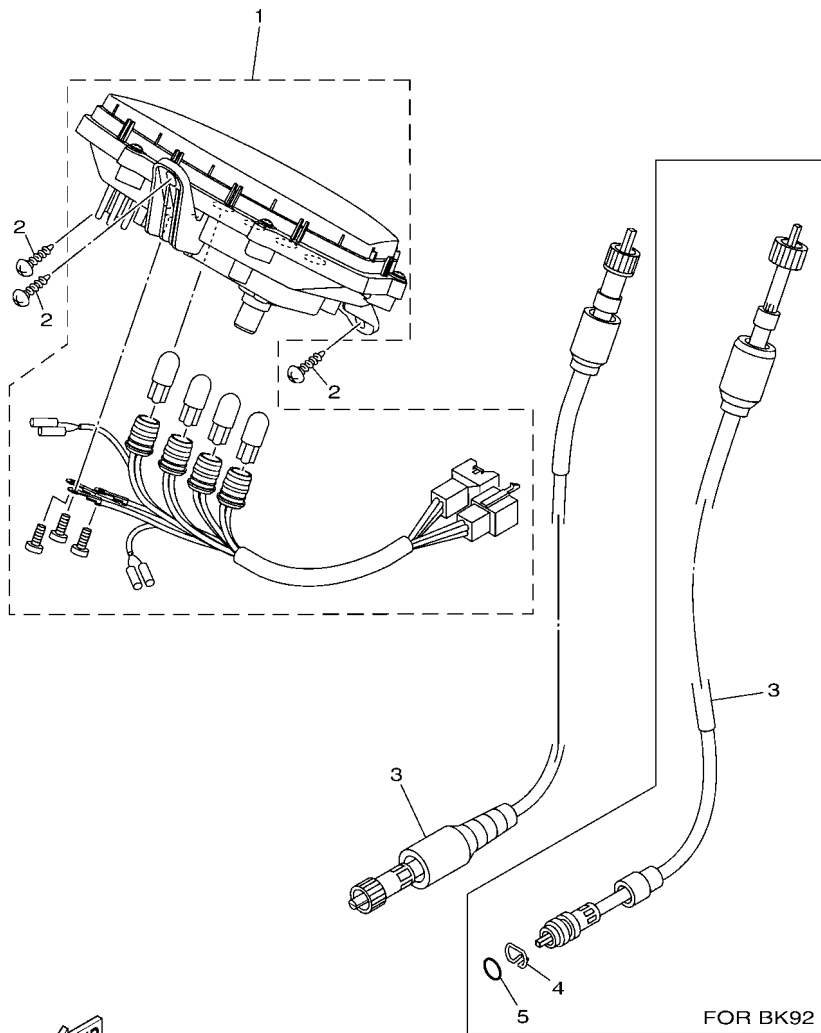

BK91415-S360

FIG. 36 仪表

METER

参照 号码	零件号码 PART NO.	零件名称 DESCRIPTION	BK91	BK92	备注 REMARKS
1	BK9-H3510-00	测速计组合 SPEEDOMETER ASSY	1	1	A, B, C, D, E, H, J车用 FOR A,B,C,D,E,H,J F, G车用 FOR F,G
	BK9-H3510-10	测速计组合 SPEEDOMETER ASSY	1		
2	97702-50016	自攻螺钉 SCREW, TAPPING	3	3	
3	BK9-H3550-00	速度计软轴组合 SPEEDOMETER CABLE ASSY	1		
	BK9-H3550-10	速度计软轴组合 SPEEDOMETER CABLE ASSY		1	
4	1JD-F5137-10	止动环 RING, STOP		1	
5	93210-10801	O型环 O-RING		1	

FIG. 37 前大灯

HEADLIGHT

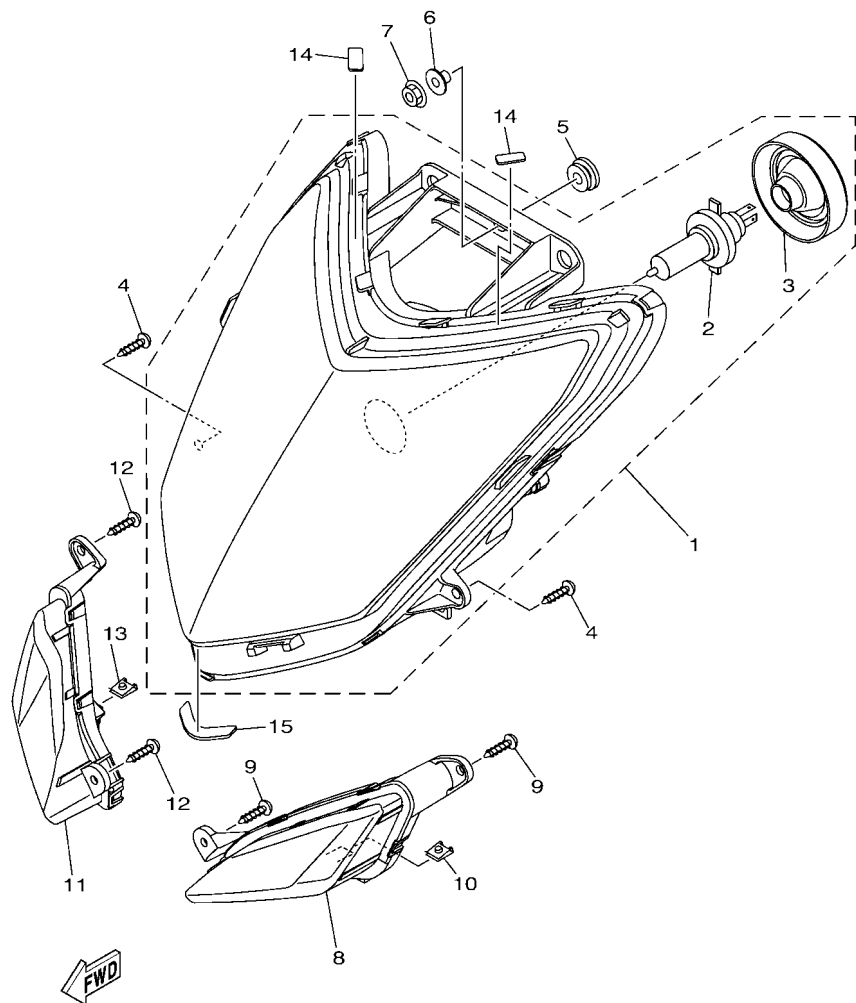

BK91415-S370

参照 号码	零件号码 PART NO.	零件名称 DESCRIPTION	BK91	BK92	备注 REMARKS
1	BK9-H4310-00	大灯组件 HEADLIGHT UNIT ASSY	1	1	
2	4S5-H4314-00	.前照灯灯泡 (12V-35/35W) .BULB, HEADLIGHT (12V-35/35W)	1	1	
3	BK9-H4378-00	.盖 .CAP	1	1	
4	97702-60020	自攻螺钉 SCREW, TAPPING	2	2	
5	90480-13398	橡胶垫 GROMMET	1	1	
6	90387-06160	轴套 COLLAR	1	1	
7	95702-06500	螺母 NUT, FLANGE	1	1	
8	BK9-H4301-00	导向灯组合1 PILOT LIGHT ASSY 1	1	1	
9	97702-50016	自攻螺钉 SCREW, TAPPING	2	2	
10	90183-05818	弹性螺母 NUT, SPRING	1	1	
11	BK9-H4302-00	导向灯组合2 PILOT LIGHT ASSY 2	1	1	
12	97702-50016	自攻螺钉 SCREW, TAPPING	2	2	
13	90183-05818	弹性螺母 NUT, SPRING	1	1	
14	BK9-F8371-00	减震垫 DAMPER	2	2	
15	BK9-F8372-00	避震垫 DAMPER	1	1	

FIG. 38 尾灯

TAILLIGHT

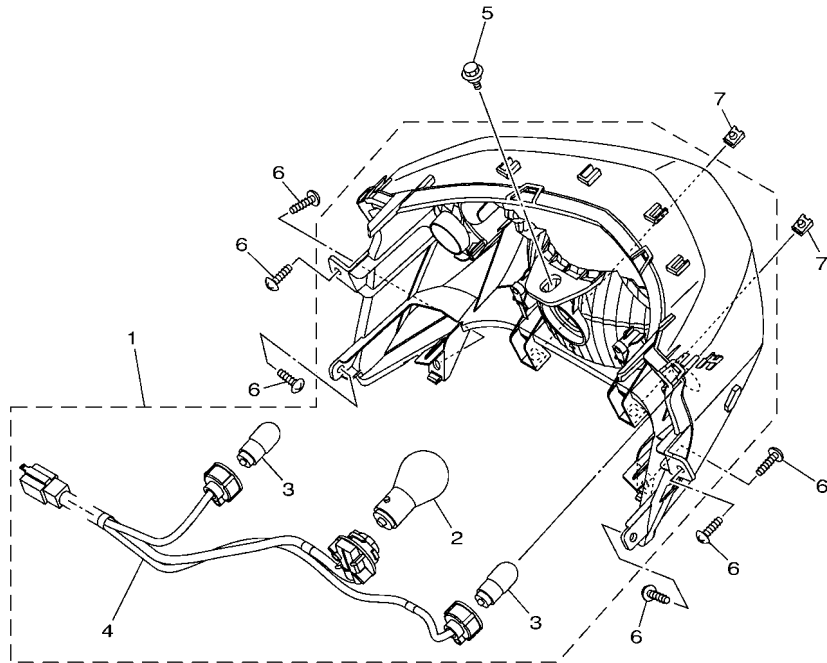

参照 号码	零件号码 PART NO.	零件名称 DESCRIPTION	BK91	BK92	备注 REMARKS
1	BK9-H4700-00	尾灯组合 TAILLIGHT ASSY	1	1	
2	4S5-H4714-00	.灯泡 .BULB (12V-21/5W)	1	1	
3	4S5-H3311-00	.转向灯灯泡 .BULB, FLASHER (12V-10W)	2	2	
4	BK9-H4717-00	.尾灯缆索 .CORD, TAILLIGHT	1	1	
5	90109-06172	螺栓 BOLT	1	1	
6	97702-50016	自攻螺钉 SCREW, TAPPING	6	6	
7	90183-05818	弹性螺母 NUT, SPRING	2	2	



BK91415-S380

FIG. 39 手柄开关(碟刹)

SWITCH & LEVER FOR DISK BRAKE

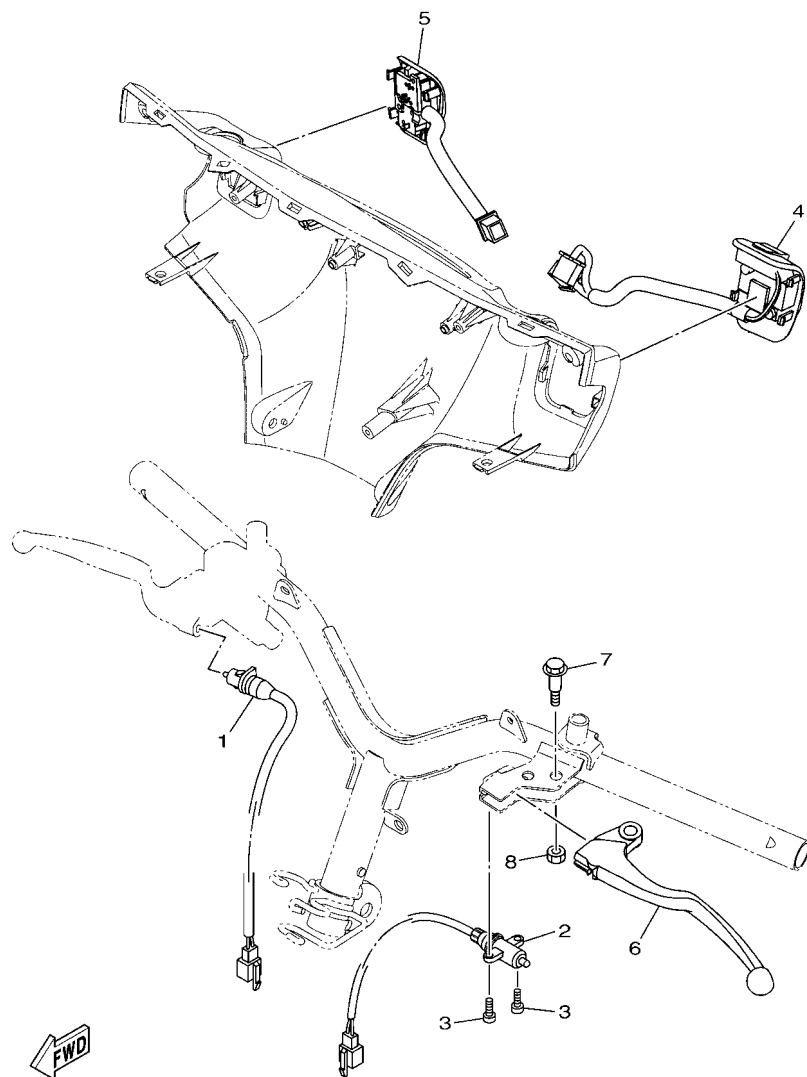

BK91415-S390

参照 号码	零件号码 PART NO.	零件名称 DESCRIPTION	BK91	BK92	备注 REMARKS
1	5MH-H3980-11	前制动开关组合 FRONT STOP SWITCH ASSY	1		
2	BE8-H3980-00	前制动开关组合 FRONT STOP SWITCH ASSY	1		
3	98502-03008	十字螺钉 SCREW, PAN HEAD	2		
4	BE8-H3963-00	手把开关3 SWITCH, HANDLE 3	1		
5	BE8-H3975-00	手把开关2 SWITCH, HANDLE 2	1		
6	BE8-H3912-00	手柄1 LEVER 1	1		
7	90109-06883	螺栓 BOLT	1		
8	95602-06100	锁紧螺母 NUT, S/L	1		

FIG. 41 电气系统1

ELECTRICAL 1

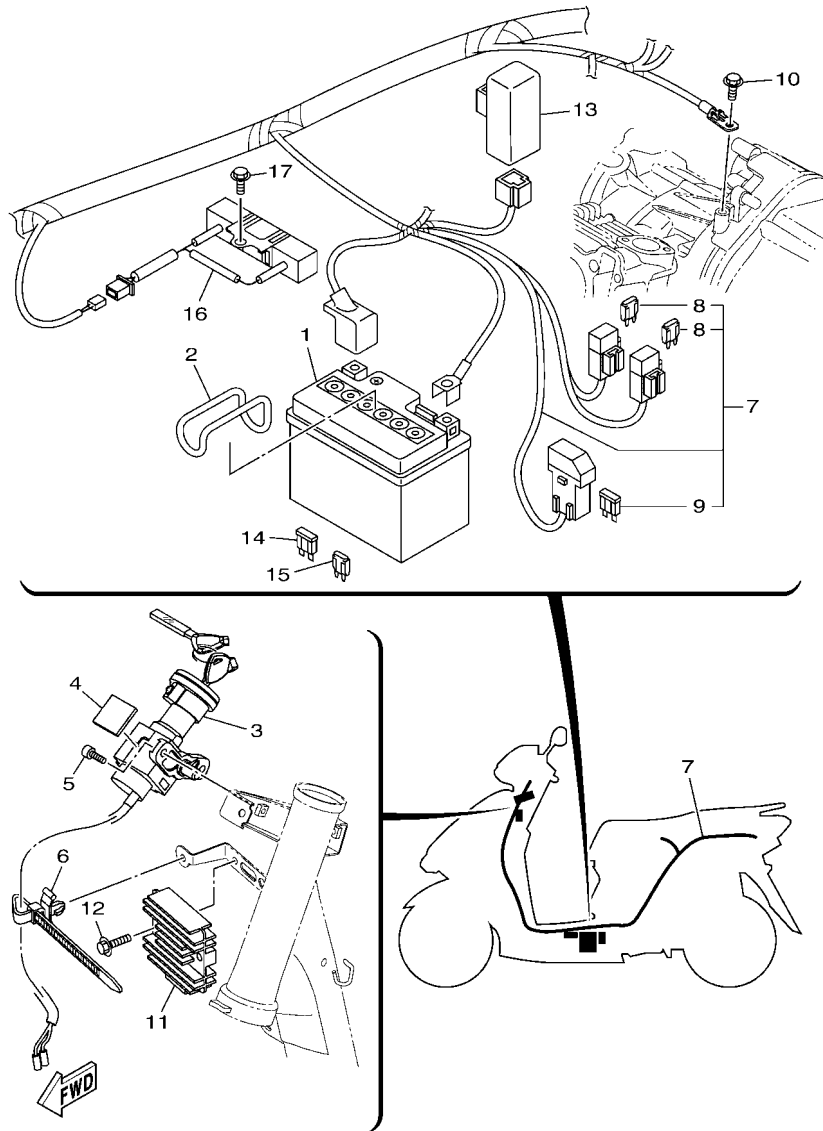

BK91415-S410

参照 号码	零件号码 PART NO.	零件名称 DESCRIPTION	BK91	BK92	备注 REMARKS
1	5WY-H2100-10	蓄电池组合 (YTX5L-BS) BATTERY ASSY (YTX5L-BS)	1	1	
2	BK9-H2131-00	蓄电池带箍 BAND, BATTERY	1	1	
3	BE8-H252E-00	主开关盖 MAIN SWITCH COMP.	1	1	
4	90520-02806	面板减震器 DAMPER, PLATE	1	1	
5	98507-06016	十字螺钉 SCREW, PAN HEAD	2	2	
6	90464-12813	线夹 CLAMP	1	1	
7	BK9-H2590-00	电缆总成 WIRE HARNESS ASSY	1	1	
8	BE8-H2151-00	. 保险丝 . FUSE (7.5A)	2	2	
9	BE8-H2151-10	. 保险丝 . FUSE (15A)	1	1	
10	95022-06012	凸缘螺栓 BOLT, FLANGE	1	1	
11	2GS-H1960-00	整流调节器 RECTIFIER & REGULATOR ASSY	1	1	
12	90105-068B5	凸缘螺栓 BOLT, FLANGE	2	2	
13	4S9-H1940-00	起动继电器组合 STARTER RELAY ASSY	1	1	
14	BE8-H2151-10	保险丝 FUSE (15A)	1	1	
15	BE8-H2151-00	保险丝 FUSE (7.5A)	1	1	
16	BE8-H5370-00	电阻组合 RESISTOR ASSY	1	1	
17	95022-06010	凸缘螺栓 BOLT, FLANGE	1	1	

FIG. 42 电气系统2

ELECTRICAL 2

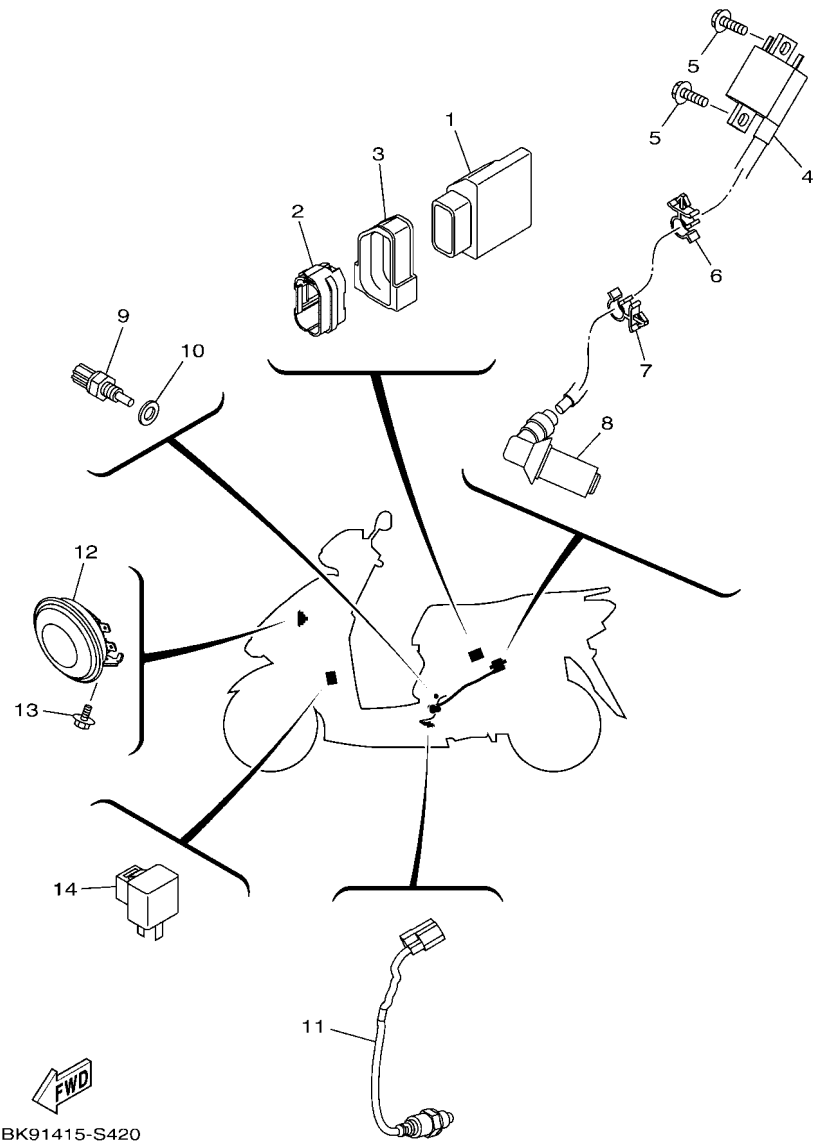

BK91415-S420

参照 号码	零件号码 PART NO.	零件名称 DESCRIPTION	BK91	BK92	备注 REMARKS
1	BE8-H591A-01	发动机控制装置组合 ENGINE CONTROL UNIT ASSY	1	1	
2	BK9-H1128-00	夹箍 CLAMP	1	1	
3	BK9-H5546-00	箍带 BAND	1	1	
4	BE8-H2310-00	点火线圈组合 IGNITION COIL ASSY	1	1	
5	95022-06020	凸缘螺栓 BOLT, FLANGE	2	2	
6	90464-09805	线夹 CLAMP	1	1	
7	90464-09805	线夹 CLAMP	1	1	
8	BE8-H2370-00	火花塞帽组合 PLUG CAP ASSY	1	1	
9	2SB-H3591-00	温控器组 THERMO UNIT	1	1	
10	90430-10200	衬垫 GASKET	1	1	
11	2BM-H592A-10	氧气传感器 SENSOR, OXYGEN	1	1	
12	BE8-H3371-00	电喇叭 HORN	1	1	
13	95022-06010	凸缘螺栓 BOLT, FLANGE	1	1	
14	5VL-H3350-21	闪烁继电器组合 FLASHER RELAY ASSY	1	1	

零件号码索引
NUMERICAL INDEX

零件号码 PART NO.	参照 号码	零件号码 PART NO.	参照 号码	零件号码 PART NO.	参照 号码	零件号码 PART NO.	参照 号码	零件号码 PART NO.	参照 号码	零件号码 PART NO.	参照 号码
BE8-E1111-00	1 - 1	BE8-E3595-00	7 - 2	BE8-E5474-00	10 - 17	BK9-F1511-00-P5	15 - 1	BK9-F312G-00	19 - 9	4TU-F3411-00	21 - 33
BE8-E111F-00	4 - 4	BE8-E3750-00	7 - 17	1CC-E5481-00	10 - 19	BK9-F1511-00-UG	15 - 1	BE8-F3141-00	20 - 13	4KL-F3411-10	18 - 5
BE8-E111G-00	1 - 7	2PH-E3761-00	7 - 9	BE8-E5495-00	10 - 15	BK9-F1552-00	32 - 9		20 - 28		19 - 5
BE8-E112F-00	4 - 5	5WG-E3769-00	9 - 21	BE8-E5512-00	11 - 6	BK9-F1611-00	15 - 3		21 - 13	4KL-F3412-20	18 - 2
BE8-E1166-00	7 - 41	2PH-E3770-00	7 - 8	BE8-E5520-00	11 - 1	BK9-F1621-00	15 - 7		21 - 28		19 - 2
2TS-E1181-00	1 - 11	2PH-E3907-00	22 - 5	BE8-E5521-00	11 - 7	BK9-F1640-00	14 - 14	BE8-F3144-00	20 - 12	4KL-F3412-30	18 - 3
BE8-E1190-00	1 - 5	54P-E3938-00	7 - 12	BE8-E5570-00	11 - 4	BK9-F1691-00	15 - 8		20 - 27		19 - 3
BE8-E1193-00	1 - 8	BE8-E3971-00	22 - 3	BE8-E5598-00	11 - 5	BK9-F1711-00	16 - 1		21 - 12	BK9-F3415-00	18 - 8
BE8-E119E-00	1 - 6	54P-E4137-00	7 - 13	2XC-E5693-00	11 - 2	BK9-F1711-10	16 - 1		21 - 27		19 - 8
BE8-E1311-00	1 - 15	BE8-E4146-00	7 - 21	BE8-E5744-00	12 - 25	BK9-F171L-00-P0	31 - 21	BE8-F3145-00	20 - 4	5MH-F3416-01	18 - 7
BE8-E1351-00	1 - 16	54P-E4147-00	7 - 10	BK9-E6111-00	12 - 1	BK9-F171L-00-P1	31 - 21		20 - 19		19 - 7
BE8-E1391-00	9 - 12	5CA-E4147-00	7 - 11	BE8-E6611-00	12 - 27	BK9-F171L-00-P2	31 - 21		21 - 4	5WG-F341E-00	18 - 1
2BM-E1631-10	2 - 5	54P-E4243-00	7 - 19	BE8-E6620-00	12 - 13	BK9-F171L-00-P3	31 - 21		21 - 19		19 - 1
BE8-E1633-00	2 - 6	BE8-E4410-00	7 - 22	BE8-E6626-00	12 - 14	BK9-F171L-00-P4	31 - 21	1FP-F3147-00	20 - 15	5WG-F341E-10	18 - 4
BE8-E2111-00	3 - 1	BE8-E4411-00	7 - 23	BE8-E7211-00	13 - 4	BK9-F171L-00-P5	31 - 21		20 - 30		19 - 4
BE8-E2113-00	3 - 4	BE8-E443E-00	7 - 30	BK9-E7410-00	13 - 1	BK9-F171L-00-UG	31 - 21		21 - 15	1FP-F3479-00	20 - 10
BE8-E2117-00	3 - 6	BE8-E443G-00	7 - 28	BE8-E7421-00	13 - 3	BK9-F171M-00-P0	31 - 23		21 - 30		20 - 25
4S5-E2118-00	3 - 5	BE8-E443H-00	10 - 4	BE8-E7465-00	12 - 17	BK9-F171M-00-P1	31 - 23	49P-F3151-00	20 - 9		21 - 10
1DB-E2119-00	3 - 3	BE8-E4450-00	7 - 25	BE8-E7465-10	12 - 18	BK9-F171M-00-P2	31 - 23		20 - 24		21 - 25
BE8-E2121-00	3 - 2	BE8-E4452-00	7 - 27	BE8-E7601-00	12 - 5	BK9-F171M-00-P3	31 - 23		21 - 9	BK9-F3857-00	18 - 12
BE8-E2126-00	3 - 7	BE8-E4453-00	7 - 26	BE8-E7602-00	12 - 12	BK9-F171M-00-P4	31 - 23		21 - 24		19 - 12
BE8-E2146-00	3 - 11	BE8-E4613-00	8 - 5	BE8-E7611-00	12 - 11	BK9-F171M-00-P5	31 - 23	4RT-F3153-00	20 - 5	BK9-F4110-00	22 - 1
BE8-E2151-00	3 - 8	BK9-E4711-00	8 - 2	BE8-E7620-00	12 - 6	BK9-F171M-00-UG	31 - 23		20 - 20	BK9-F414E-00	22 - 2
BE8-E2159-00	3 - 10	BE8-E4718-00	8 - 3	BE8-E7623-00	12 - 8	BK9-F191B-00	14 - 19		21 - 5	1DB-F414G-01	22 - 6
BE8-E2176-00	4 - 8	BE8-E5111-00	9 - 1	BE8-E7632-00	12 - 7	BK9-F191C-00	14 - 20		21 - 20	BE8-F4170-00	22 - 19
2BM-E2210-00	4 - 14	BE8-E5113-00	9 - 19	BE8-E7641-00	12 - 28	BE8-F2141-00	14 - 11	1FP-F3157-00	20 - 8	BK9-F41B1-00	22 - 11
BE8-E2213-00	4 - 15	BE8-E5118-00	4 - 16	BE8-E7645-00	12 - 33				20 - 23	BK9-F4313-00	22 - 17
BE8-E2228-00	4 - 18	BE8-E5121-00	9 - 2	4KL-E7653-20	12 - 9				21 - 8	BK9-F4314-00	22 - 21
BE8-E2231-00	4 - 10	BE8-E5155-00	9 - 3	BE8-E7660-00	12 - 15	BE8-F2210-00	17 - 1		21 - 23	BK9-F4491-00	22 - 7
BE8-E2233-00	4 - 11	BE8-E5191-00	10 - 6	BE8-E7664-00	12 - 19	BK9-F3100-00	20 - 1	BE8-F3171-00	20 - 7	BE8-F4610-00	22 - 15
BE8-E2241-00	4 - 13	2TD-E5316-00	10 - 13	BE8-E7668-00	12 - 23	BK9-F3100-10	21 - 1		20 - 22	BK9-F4633-00	22 - 16
BE8-E2611-00	6 - 11	BE8-E5333-00	10 - 12	BE8-E7670-00	12 - 16	BK9-F3102-00	20 - 2		21 - 7	BK9-F4727-00	23 - 4
BE8-E261C-00	6 - 4	BE8-E5346-00	9 - 7	BE8-E7674-00	12 - 10	BK9-F3102-10	21 - 2		21 - 22	BK9-F472T-00	23 - 13
BE8-E2651-00	6 - 1		10 - 3	BE8-E7674-10	12 - 20	BK9-F3103-00	20 - 17	1FP-F3183-00	20 - 16	BK9-F4730-00	23 - 1
BE8-E2652-00	6 - 3	BE8-E5351-00	5 - 4	BE8-E7678-00	12 - 24	BK9-F3103-10	21 - 17		20 - 31	BK9-F4730-10	23 - 1
BE8-E2653-00	6 - 5	BE8-E5362-00	9 - 20	BE8-E7678-10	12 - 26	BK9-F3106-00	20 - 3		21 - 16	BK9-F4730-20	23 - 1
BE8-E2658-00	6 - 2	4KL-E5363-00	9 - 17	BE8-E7683-00	12 - 21	BK9-F3106-10	21 - 3		21 - 31	BK9-F473R-00	23 - 5
BE8-E2659-00	6 - 7	BE8-E5373-00	9 - 8	BE8-E7684-00	12 - 22	BK9-F3107-00	20 - 18	BK9-F3317-00	18 - 10	BK9-F4741-00	23 - 3
BE8-E2668-00	6 - 8	BE8-E5407-00	10 - 16	BK9-F1110-00	14 - 1	BK9-F3107-10	21 - 18		19 - 10	BK9-F475M-00	23 - 2
BE8-E3300-00	5 - 1	BE8-E5411-00	10 - 1	BK9-F116B-00	14 - 16	BE8-F3110-00	20 - 6	BE8-F3340-00	20 - 32	BK9-F4773-00-8L	23 - 10
BE8-E3324-00	2 - 3	BE8-E5417-00	9 - 22	BE8-F1410-00	14 - 6		20 - 21	BE8-F3340-10	21 - 32	BK9-F4773-00-P0	23 - 10
BE8-E3411-00	5 - 5	BE8-E5421-00	9 - 35	BE8-F1439-00	28 - 31		21 - 6	1FP-F3346-00	20 - 34	BK9-F4773-00-P1	23 - 10
BE8-E3475-00	5 - 2	BE8-E5423-00	9 - 29		29 - 35		21 - 21		21 - 34	BK9-F4773-00-P2	23 - 10
BE8-E3556-00	7 - 3	BE8-E5451-00	10 - 2	BK9-F1511-00-P0	15 - 1	1FP-F3111-00	20 - 14	1FP-F3356-00	20 - 11	BK9-F4773-00-P3	23 - 10
BE8-E3557-00	7 - 14	BE8-E5453-00	9 - 25	BK9-F1511-00-P1	15 - 1		20 - 29		20 - 26	BK9-F4773-00-P4	23 - 10
BE8-E3569-00	6 - 13	BE8-E5461-00	9 - 36	BK9-F1511-00-P2	15 - 1		21 - 14		21 - 11	BK9-F4773-00-UG	23 - 10
BE8-E3585-00	7 - 1	BE8-E5472-00	10 - 14	BK9-F1511-00-P3	15 - 1		21 - 29		21 - 26	BE8-F4780-00	23 - 7
BE8-E3593-00	7 - 5	BE8-E5473-00	10 - 11	BK9-F1511-00-P4	15 - 1	BK9-F312G-00	18 - 9	4TU-F3411-00	20 - 33	BE8-F478E-00	23 - 8

零件号码索引
NUMERICAL INDEX

零件号码 PART NO.	参照 号码	零件号码 PART NO.	参照 号码	零件号码 PART NO.	参照 号码	零件号码 PART NO.	参照 号码	零件号码 PART NO.	参照 号码	零件号码 PART NO.	参照 号码
BE8-F5121-00-35	25 - 10	BK9-F6145-00	29 - 28	BK9-F8311-00-P3	32 - 1	BE8-H3975-00	40 - 5	BK9-W2614-00-P4	28 - 21	90154-06807	15 - 2
BE8-F5121-00-P0	25 - 10	BK9-F6145-10	28 - 24	BK9-F8311-00-UG	32 - 1	BE8-H3980-00	39 - 2	BK9-W2614-00-P5	28 - 21	90160-05803	28 - 25
BK9-F5135-00	25 - 13		29 - 28	BK9-F8349-00	32 - 5		40 - 1	BK9-W2614-00-UG	28 - 21		29 - 29
BE8-F5136-00	25 - 14	BE8-F6240-00	28 - 7	BK9-F8349-10	32 - 5	5MH-H3980-11	39 - 1		29 - 25	90170-05302	3 - 9
1JD-F5137-10	36 - 4		29 - 7	BK9-F834V-00	14 - 13	BK9-H4301-00	37 - 8	BK9-W2830-00	32 - 3	90170-12800	12 - 37
BK9-F5138-00	25 - 15	BK9-F6240-00	28 - 7	BK9-F8371-00	37 - 14	BK9-H4302-00	37 - 11	BK9-W2830-10	32 - 3	90170-12802	12 - 32
4KL-F513A-01	25 - 22		29 - 7	BK9-F8372-00	37 - 15	BK9-H4310-00	37 - 1	BK9-W2831-00-P4	32 - 1	90179-06835	28 - 19
BE8-F5151-00	25 - 20	BE8-F6241-00	28 - 6	BE8-F8379-00	32 - 7	4S5-H4314-00	37 - 2	BK9-W2831-00-P5	32 - 1		29 - 19
BE8-F5155-00	25 - 17		29 - 6	BK9-F8379-00	32 - 7	BK9-H4378-00	37 - 3	BK9-W2834-00-P0	32 - 12		29 - 23
BE8-F5168-00-35	24 - 1	BK9-F6241-00	28 - 6	BK9-H1128-00	42 - 2	BK9-H4700-00	38 - 1	BK9-W2834-00-P1	32 - 12	90179-12004	33 - 6
BE8-F5168-00-8L	24 - 1		29 - 6	BE8-H1410-00	33 - 2	4S5-H4714-00	38 - 2	BK9-W2834-00-P2	32 - 12	90179-25812	18 - 6
BE8-F5168-00-P0	24 - 1	BE8-F6246-00	28 - 8	BE8-H1450-00	33 - 1	BK9-H4717-00	38 - 4	BK9-W2834-00-P3	32 - 12		19 - 6
BE8-F5168-10-35	25 - 1		29 - 8	BE8-H1801-00	34 - 2	4P7-H5130-20	16 - 13	BK9-W2834-00-UG	32 - 12	90183-05818	15 - 4
BE8-F5168-10-P0	25 - 1	BK9-F6257-00	31 - 18	1JD-H1828-00	34 - 4	4S5-H5131-00	32 - 14	BE8-WE412-00	7 - 24		16 - 4
BK9-F5190-00	24 - 10	BE8-F6280-00	28 - 28	4S9-H1834-00	34 - 3	BE8-H5370-00	41 - 16	BE8-X1161-10	2 - 8		16 - 8
BE8-F5326-00	27 - 12		29 - 32	BE8-H1890-00	34 - 1	BK9-H5546-00	42 - 3	BE8-X1217-00	4 - 1		28 - 22
BE8-F5338-00-35	27 - 1	BE8-F6281-00	28 - 9	4S9-H1940-00	41 - 13	2TD-H5801-00	7 - 18	BE8-X1400-00	2 - 1		28 - 26
BE8-F5338-00-8L	27 - 1		29 - 9	2GS-H1960-00	41 - 11	BE8-H591A-01	42 - 1	BK9-Y1471-00	8 - 1		29 - 26
BE8-F5338-00-P0	27 - 1	BE8-F6282-00	28 - 10	5WY-H2100-10	41 - 1	2BM-H592A-10	42 - 11	BE8-Y2530-00	27 - 4		29 - 30
BE8-F533A-00	27 - 9		29 - 10	BK9-H2129-00	31 - 19	4S9-W0041-01	30 - 5	90101-06046	25 - 18		31 - 11
BE8-F5351-00	27 - 7	BE8-F6290-00	28 - 29	BK9-H2129-10	31 - 19	4S5-W0045-00	26 - 6		27 - 11		32 - 10
BE8-F5355-00	27 - 10		29 - 33	BK9-H2131-00	41 - 2	4S5-W0047-00	26 - 5	90101-08829	31 - 14		32 - 13
BE8-F580U-10	26 - 3	BK9-F6311-00	28 - 12	BE8-H2151-00	41 - 8	4S5-W0048-01	26 - 7	90105-068B5	41 - 12		35 - 5
BE8-F582U-00	26 - 1		29 - 12		41 - 15	4S5-W0057-00	26 - 4	90105-07801	4 - 7		37 - 10
4S9-F583T-01	30 - 4	BK9-F6341-00	29 - 17	BE8-H2151-10	41 - 9	BK9-W2172-00-P0	16 - 3	90105-088E8	17 - 2		37 - 13
4S9-F5852-00	30 - 7	BK9-F6351-00	28 - 17		41 - 14	BK9-W2172-00-P1	16 - 3		17 - 4		38 - 7
4S9-F5854-00	30 - 6		29 - 21	BE8-H2310-00	42 - 4	BK9-W2172-00-P2	16 - 3	90105-10210	14 - 9	90185-10011	28 - 4
4S9-F5855-00	30 - 11	BE8-F637G-00	28 - 30	BE8-H2370-00	42 - 8	BK9-W2172-00-P3	16 - 3	90105-10295	28 - 3		29 - 4
4S9-F5867-00	30 - 10		29 - 34	BE8-H252E-00	41 - 3	BK9-W2172-00-P4	16 - 3		29 - 3	90185-16800	27 - 16
3D9-F586F-01	30 - 13	BK9-F7111-00	31 - 1	BK9-H2590-00	41 - 7	BK9-W2172-00-P5	16 - 3	90105-10831	26 - 15	90201-062G3	14 - 18
BK9-F5872-00	30 - 1	BK9-F7112-00	31 - 2	BK9-H3301-00	35 - 1	BK9-W2172-00-UG	16 - 3	90109-06172	38 - 5	90201-10118	30 - 3
BK9-F5875-00	18 - 16	BK9-F7114-00	14 - 8	4S5-H3311-00	35 - 2	BK9-W2173-00-P0	16 - 7	90109-06202	15 - 5	90201-12172	9 - 14
BK9-F5887-00	18 - 17	BE8-F7121-00	9 - 4		38 - 3	BK9-W2173-00-P1	16 - 7		22 - 20	90201-12823	33 - 5
4KL-F5896-00	30 - 9	BE8-F7254-00	31 - 5	BK9-H331E-00	35 - 3	BK9-W2173-00-P2	16 - 7		23 - 6	90201-15848	12 - 38
3D9-F589F-01	30 - 14	BK9-F7267-00	31 - 6	5VL-H3350-21	42 - 14	BK9-W2173-00-P3	16 - 7		31 - 12	90201-165H4	12 - 35
4KL-F589H-01	30 - 8	BK9-F7311-00	31 - 13	BE8-H3371-00	42 - 12	BK9-W2173-00-P4	16 - 7	90109-06265	32 - 8	90201-16811	27 - 17
4S5-F5917-00	26 - 12	BK9-F7431-00	31 - 25	BK9-H3510-00	36 - 1	BK9-W2173-00-P5	16 - 7	90109-06883	39 - 7	90201-16816	12 - 39
4S5-F5919-00	26 - 11	BK9-F7437-00	31 - 29	BK9-H3510-10	36 - 1	BK9-W2173-00-UG	16 - 7		40 - 7	90201-20823	25 - 16
4S9-F5921-01	26 - 8	BK9-F7441-00	31 - 26	BK9-H3550-00	36 - 3	BK9-W217F-00	16 - 11	90109-08232	26 - 2	90201-220J8	27 - 15
4S5-F5924-01	26 - 13	BK9-F7475-00	31 - 10	BK9-H3550-10	36 - 3	BE8-W253A-00	25 - 11	90110-06846	7 - 16	90206-14802	27 - 8
4S5-F5925-00	26 - 14	BK9-F7475-10	31 - 10	2SB-H3591-00	42 - 9	BK9-W2614-00-P0	28 - 21	90110-06868	1 - 14	90208-12809	12 - 36
4S5-F5937-00	26 - 9	BK9-F7481-00	31 - 7	BE8-H3912-00	39 - 6		29 - 25	90111-06807	8 - 4	90249-12806	28 - 20
4S5-F5939-00	26 - 10	BK9-F7481-10	31 - 7		40 - 6	BK9-W2614-00-P1	28 - 21	90119-06155	15 - 6		29 - 20
BK9-F6110-00	28 - 1	BE8-F814F-00	23 - 14	4S9-H3922-00	30 - 12		29 - 25		22 - 2		29 - 24
BK9-F6110-10	29 - 1	5AP-F8152-00	23 - 15	BE8-H3922-00	40 - 3	BK9-W2614-00-P2	28 - 21	90119-06869	31 - 9	90269-06809	16 - 5
BK9-F6113-00	28 - 2	BK9-F8311-00-P0	32 - 1	BE8-H3963-00	39 - 4		29 - 25	90119-068B7	22 - 13		16 - 9
	29 - 2	BK9-F8311-00-P1	32 - 1		40 - 4	BK9-W2614-00-P3	28 - 21	90119-068C6	23 - 11		28 - 27
BK9-F6145-00	28 - 24	BK9-F8311-00-P2	32 - 1	BE8-H3975-00	39 - 5		29 - 25	90119-068C7	23 - 12		29 - 31

零件号码索引
NUMERICAL INDEX

零件号码 PART NO.	参照 号码	零件号码 PART NO.	参照 号码	零件号码 PART NO.	参照 号码	零件号码 PART NO.	参照 号码	零件号码 PART NO.	参照 号码	零件号码 PART NO.	参照 号码
90269-06809	31 - 22	90506-15802	27 - 5	93306-201YS	12 - 2	95602-05200	16 - 14	98502-06012	7 - 20		
	31 - 24	90506-15803	25 - 12	93306-204XX	12 - 3	95602-06100	39 - 8	98507-06016	41 - 5		
90280-03045	2 - 4	90506-20829	31 - 17	93306-272YB	13 - 5		40 - 8	98902-05008	34 - 7		
90338-13800	7 - 32	90506-32812	31 - 4	93306-300YG	24 - 2	95602-08200	31 - 16	99002-09600	31 - 3		
90340-12806	9 - 13	90520-02806	22 - 9		25 - 2	95602-10200	14 - 10	99009-25400	13 - 7		
90380-10802	12 - 30		41 - 4	93306-303YU	13 - 8		14 - 12	99009-35700	12 - 31		
90387-06160	37 - 6	90520-02823	14 - 2	93306-351Y8	13 - 2		24 - 9	99480-05010	9 - 26		
90387-064H8	31 - 32		22 - 10	93306-372X7	2 - 2		25 - 9	99530-10114	1 - 12		
90387-064W3	7 - 34	90520-02829	14 - 3	933A6-202Y0	12 - 29	95612-08618	1 - 4		1 - 13		
90387-08820	31 - 15	90520-05819	6 - 6	93450-14088	2 - 7	95702-06500	37 - 7		9 - 10		
90387-10841	24 - 3	90520-08813	31 - 8	93450-32837	11 - 3	95702-08500	8 - 6		9 - 32		
90387-10845	24 - 7	90520-10811	7 - 36	93501-04805	31 - 28	95702-10500	27 - 13		9 - 37		
90387-10846	25 - 3	90520-10825	7 - 37	93900-00827	24 - 6	95802-06012	14 - 17		10 - 9		
90387-10847	25 - 7		32 - 4		25 - 6	95812-06016	6 - 12				
90388-08803	9 - 5	90520-15004	7 - 38		27 - 2	95812-06025	7 - 15				
90388-10817	9 - 6	91312-05010	22 - 8	94110-10821	24 - 5		7 - 40				
	14 - 7	91312-06012	4 - 6		25 - 5	95812-06035	7 - 6				
90401-10823	30 - 2		4 - 12	94110-10822	27 - 3	95812-06040	9 - 15				
90430-06014	1 - 3		14 - 15	94568-J7092	4 - 9	95812-06045	7 - 7				
	9 - 16	91312-06016	33 - 3	94700-00869	1 - 10	95812-08055	8 - 7				
90430-10200	42 - 10		33 - 4	95022-06010	1 - 2	95822-06020	6 - 9				
90450-46803	7 - 39	91312-06020	34 - 5		10 - 7	95822-06090	10 - 18				
90462-10822	10 - 8	91312-06025	30 - 15		41 - 17	97602-05212	23 - 9				
90464-09805	22 - 18	91402-20012	31 - 31		42 - 13	97702-50012	28 - 23				
	28 - 16	91702-06038	31 - 30	95022-06012	18 - 11		29 - 27				
	29 - 16	91A11-07008	22 - 14		18 - 13	97702-50016	28 - 5				
	42 - 6	92012-05010	28 - 14		18 - 14		29 - 5				
	42 - 7		29 - 14		18 - 15		32 - 2				
90464-10803	28 - 15	92012-05016	28 - 13		19 - 11		32 - 11				
	29 - 15		29 - 13		19 - 13		35 - 4				
	41 - 6	93102-19820	9 - 23		41 - 10		36 - 2				
90464-15806	22 - 4	93102-20817	12 - 4	95022-06014	28 - 33		37 - 9				
	9 - 9	93102-25823	9 - 30		29 - 37		37 - 12				
90467-110A3	10 - 5	93102-32810	13 - 6	95022-06020	4 - 17		38 - 6				
90467-11800	7 - 33	93105-47801	25 - 21		9 - 28	97702-60020	37 - 4				
90467-12804	7 - 31	93106-20813	24 - 4		42 - 5	97702-60530	6 - 10				
90467-13042	7 - 42		25 - 4	95022-06025	9 - 33	97707-50012	16 - 2				
90467-13813	7 - 43	93210-07890	27 - 14	95022-06035	9 - 34		16 - 12				
90480-12237	14 - 4	93210-09859	4 - 2		9 - 38		31 - 20				
90480-13013	7 - 35	93210-10801	36 - 5		10 - 10	97707-50016	16 - 6				
90480-13398	37 - 5	93210-14104	9 - 18		28 - 32		16 - 10				
90480-16804	14 - 5	93210-16807	12 - 34		29 - 36		32 - 6				
90501-10814	29 - 18	93210-29800	5 - 7	95022-06045	9 - 39	97707-50025	7 - 29				
90501-12743	31 - 27	93210-29811	34 - 6	95022-06060	9 - 11	98502-03008	39 - 3				
90501-16003	28 - 18	93210-35895	7 - 4	95022-06070	9 - 27		40 - 2				
	29 - 22	93211-07805	9 - 24	95302-06600	25 - 19	98502-05020	5 - 3				
90501-16004	5 - 6	93211-47800	9 - 31	95302-08600	1 - 9	98502-05025	28 - 11				
90506-12801	27 - 6	93306-001YG	4 - 3		17 - 3		29 - 11				