

翻印必究



上海雅马哈建设摩托车销售有限公司

<http://www.yamaha-motor.com.cn/>

第一版 2013年6月



SHANGHAI YAMAHA JIANSHE MOTOR MARKETING CO., LTD.

零件目录

XC100 (2JP1)

2JP-F8198-1M-M1

1M2JP-415M1



XC100 (2JP1)



2JP1 (手鼓)

代号	颜色
0903	金属黑



2JP1 (手鼓)

代号	颜色
0918	深金属红



2JP1 (手鼓)

代号	颜色
00UG	香槟金



2JP1 (手鼓)

代号	颜色
0776	浅蓝



前言

本零件目录记载着封面页所示型号所使用的零件。当您订购更换零件时，请参阅本零件目录并正确指示零件号码和零件名称。

1. 零件目录发行后有变更或附加零件时，将会以雅马哈零件信息通知大家。
建议您应按照雅马哈零件信息修改本零件目录。

2. 省略记号

本文中所记载的省略记号的意思如下。

“UR” 需要指定的零件号码。

“UN” 需要数。

“AP” 选购品

“LM” 当地制造（必需于当地订购的零件）

“F#” 车架号（适用的机器号）

“O/S” 超过尺寸

3. 组件中部件的数量

- 组件的销售零件，如下所示，在零件名称的前面加上（.）的记号来表示。
- 每个部件右侧的数字表示各组件单体内该部件的数量。

零件号码	零件名称	数量	备注
2F5 - 83310 - 60	前闪光灯组合	2	
115 - 83311 - 60	. 灯泡 (6V - 18W)	1	

4. 适用的图形颜色表示在“备注”中，如下所示。

零件号码	零件名称	数量	备注
2N4 - 24110 - 00 - X5	燃油箱组件	2	MXR
3J1 - 24240 - 10	. 燃油箱图形	1	适用于 MXR

5. 请注意插图只用于找寻零件号码时参照，并不适用于组装。组装时，请使用适用的维修手册。

6. 在参照号码前的星号（*）表示其为在第一版后更改的项目。

前言

7. 适用的系列号码

车架系列号

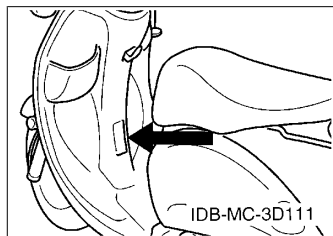

发动机系列号码

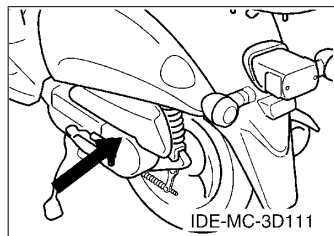

8. 适用的颜色记号 (*标志表示型号颜色。)

省略记号	颜色名称 (英文)	颜色名称	颜色记号
DRMK (*)	DEEP RED METALLIC K	浓红	0918
IPB (*)	IMPERIAL BROWN	棕色	00UG
PPBM3 (*)	PALE PURPLISH BLUE METALLIC 3	发紫浅蓝 3	0776
SMX (*)	BLACK METALLIC X	金属黑色	0903
YB	YAMAHA BLACK	雅马哈黑色	0033

9. 适用的初始系列号码

车架系列号

系列号码	数量栏名称	型号记号

发动机系列号码

系列号码	数量栏名称	型号记号

目录

发动机

气缸头.....	1
曲柄·活塞.....	2
凸轮轴·链条.....	3
空气罩&风扇.....	4
油泵.....	5
进气门.....	6
化油器.....	7
排气装置.....	8
曲轴箱.....	9
起动机.....	11
离合器.....	12
传动.....	13

车体

车架.....	14
挡泥板.....	15
侧盖.....	16
后臂·悬挂.....	17
前叉(鼓刹).....	18
油箱.....	20
座位.....	22
前轮(鼓刹).....	23
后轮.....	25
操纵手柄 钢索(鼓刹).....	26
搁脚·支架.....	27
护腿.....	28
导流罩 1.....	29
发电机.....	30
起动机.....	31
转向灯.....	32
仪表.....	33
前大灯.....	34
尾灯.....	35
手柄开关(鼓刹).....	36
电气系统 1.....	37

索引

零件号码索引.....	38
-------------	----

CONTENTS

ENGINE

CYLINDER HEAD.....	1
CRANKSHAFT & PISTON.....	2
CAMSHAFT & CHAIN.....	3
AIR SHROUD & FAN.....	4
OIL PUMP.....	5
INTAKE.....	6
CARBURETOR.....	7
EXHAUST.....	8
CRANKCASE.....	9
STARTER.....	11
CLUTCH.....	12
TRANSMISSION.....	13

CHASSIS

FRAME.....	14
FENDER.....	15
SIDE COVER.....	16
REAR ARM & SUSPENSION.....	17
FRONT FORK FOR DRUM BRAKE.....	18
FUEL TANK.....	20
SEAT.....	22
FRONT WHEEL FOR DRUM BRAKE.....	23
REAR WHEEL.....	25
STEERING CABLE FOR DRUM BRAKE.....	26
STAND & FOOTREST.....	27
LEG SHIELD.....	28
COWLING 1.....	29
GENERATOR.....	30
STARTING MOTOR.....	31
FLASHER LIGHT.....	32
METER.....	33
HEADLIGHT.....	34
TAILLIGHT.....	35
SWITCH & LEVER FOR DRUM BRAKE.....	36
ELECTRICAL 1.....	37

INDEX

NUMERICAL INDEX.....	38
----------------------	----

FIG. 1 气缸头

CYLINDER HEAD

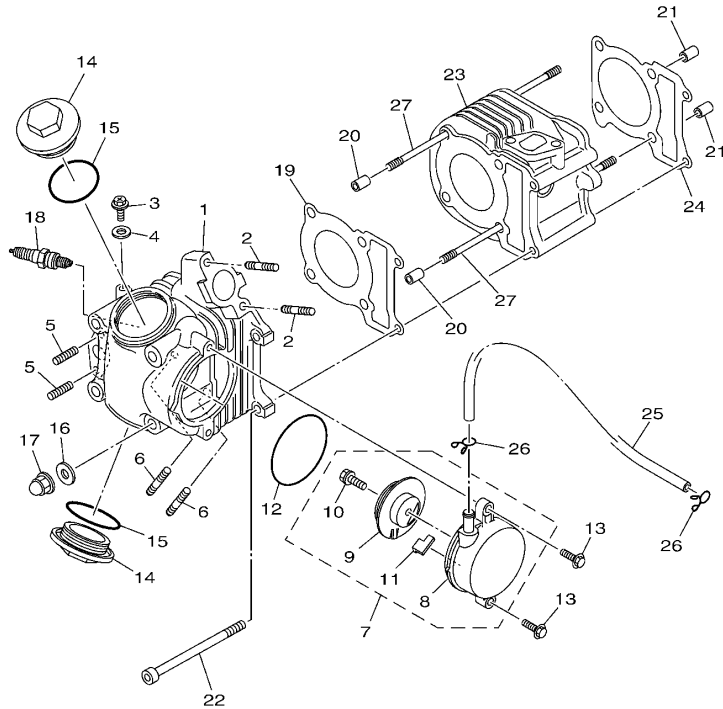



2JP1415-M010

参照 号码	零件号码 PART NO.	零件名称 DESCRIPTION	2/P1				备注 REMARKS
1	5WB-E1111-20	气缸头 1 HEAD, CYLINDER 1	1				
2	5WB-E4651-01	螺栓 BOLT	2				
3	90153-06806	六角头螺钉 SCREW, HEXAGON	1				
4	90430-06800	衬垫 GASKET	1				
5	90113-06804	离合杆螺栓 BOLT, SET	2				
6	90116-06820	双头螺栓 BOLT, STUD	2				
7	5WB-E1160-02	通气管组合 BREATHER ASSY	1				
8	5WB-E1185-01	气缸头侧盖 3 COVER, CYLINDER HEAD SIDE 3	1				
9	5WB-E1165-01	通气管面板 PLATE, BREATHER	1				
10	97522-06512	带垫螺栓 BOLT, WITH WASHER	1				
11	5WB-E1155-00	曲折环式密封圈 SEAL, LABYRINTH	1				
12	93210-62802	O型环 O-RING	1				
13	95022-06020	凸缘螺栓 BOLT, FLANGE	2				
14	5WB-E1186-00	气缸头侧盖 2 COVER, CYLINDER HEAD SIDE 2	2				
15	93210-44807	O型环 O-RING	2				
16	90201-08827	平垫圈 WASHER, PLATE	4				
17	90176-08812	盖型螺母 NUT, CROWN	4				
18	94700-00869	火花塞 PLUG SPARK (NGK CR6HSA)	1				
19	5WB-E1181-00	气缸头衬垫 1 GASKET, CYLINDER HEAD 1	1				
20	91810-14805	定位销 PIN, DOWEL	2				
21	91810-14805	定位销 PIN, DOWEL	2				
22	91312-06090	螺栓 BOLT	2				
23	5WB-E1310-01	气缸 CYLINDER	1				
24	5WB-E1351-10	气缸衬垫 GASKET, CYLINDER	1				
25	90445-14805	软管 HOSE	1				
26	90467-13804	卡环 CLIP	2				
27	90116-08811	双头螺栓 BOLT, STUD	4				

FIG. 2 曲柄·活塞

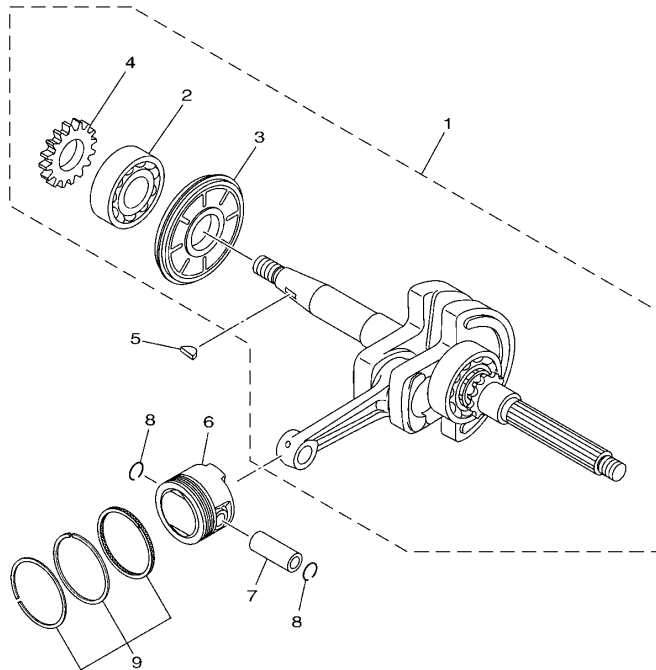
CRANKSHAFT & PISTON



参照 号码	零件号码 PART NO.	零件名称 DESCRIPTION	2, P1				备注 REMARKS
1	5WB-E1400-01	曲轴组合 CRANKSHAFT ASSY	1				
2	93306-205XL	. 轴承 . BEARING	1				
3	5WB-E3451-00	. 转子过滤器 . FILTER, ROTARY	1				
4	5WB-E3324-00	. 机油泵驱动齿轮 . GEAR, PUMP DRIVE	1				
5	90280-03801	半圆键 KEY, WOODRUFF	1				
6	5WB-E1631-00	活塞 (STD) PISTON (STD)	1				
7	5WB-E1633-00	活塞销 PIN, PISTON	1				
8	93450-15825	卡环 CIRCLIP	2				
9	5WB-E1603-00	活塞环套件 (STD) PISTON RING SET (STD)	1				

5WY3415-C020

FIG. 3 凸轮轴·链条

CAMSHAFT & CHAIN

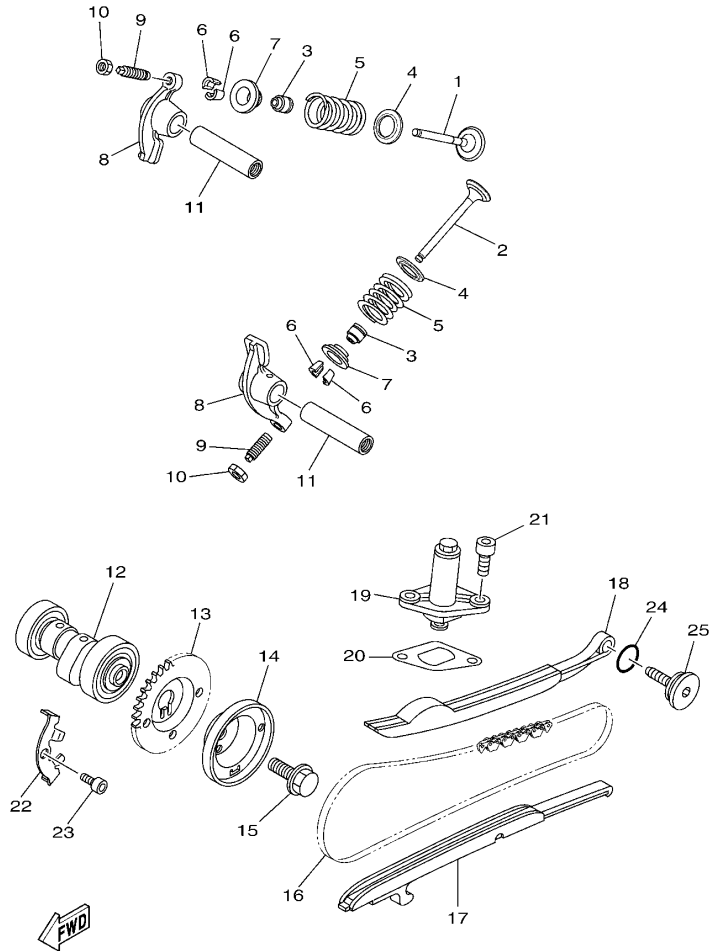

2JP1415-M030

参照 号码	零件号码 PART NO.	零件名称 DESCRIPTION	2, P1				备注 REMARKS
1	5WB-E2111-00	进气门 VALVE, INTAKE	1				
2	5WB-E2121-00	排气门 VALVE, EXHAUST	1				
3	5WB-E2119-00	气门油封 SEAL, VALVE STEM	2				
4	5WB-E2116-00	气门弹簧座 SEAT, VALVE SPRING	2				
5	5WB-E2113-00	气门内弹簧 SPRING, VALVE INNER	2				
6	5WB-E2118-00	气门锁夹 LOCK, VALVE SPRING RETAINER	4				
7	5WB-E2117-00	气门弹簧座 RETAINER, VALVE SPRING	2				
8	5WB-E2151-00	气门摇臂 ARM, VALVE ROCKER	2				
9	5WB-E2159-00	气门调整螺钉 SCREW, VALVE ADJUSTING	2				
10	90170-05801	螺母 NUT	2				
11	5WB-E2156-00	摇臂轴 2 SHAFT, ROCKER 2	2				
12	5WB-E2170-00	凸轮轴组合 1 CAMSHAFT ASSY 1	1				
13	5WB-E2176-10	链轮 SPROCKET, CAM CHAIN	1				
14	5WB-E1145-01	通气管面板 2 PLATE, BREATHER 2	1				
15	95812-08016	凸缘螺栓 BOLT, FLANGE	1				
16	94568-A2084	链条 CHAIN	1				
17	5WB-E2231-00	导向限位板 1 GUIDE, STOPPER 1	1				
18	5WB-E2241-00	导向限位板 2 GUIDE, STOPPER 2	1				
19	5WB-E2210-00	链条张紧器组合 TENSIONER ASSY, CAM CHAIN	1				
20	5WB-E2213-10	张紧器垫片 GASKET, TENSIONER CASE	1				
21	91312-06016	螺栓 BOLT	2				
22	5WB-E111F-00	面板 PLATE	1				
23	91312-06012	螺栓 BOLT	1				
24	93210-15802	O型环 O-RING	1				
25	5WB-E2157-01	锁紧螺母 BOLT	1				

FIG. 4 空气罩&风扇

AIR SHROUD & FAN

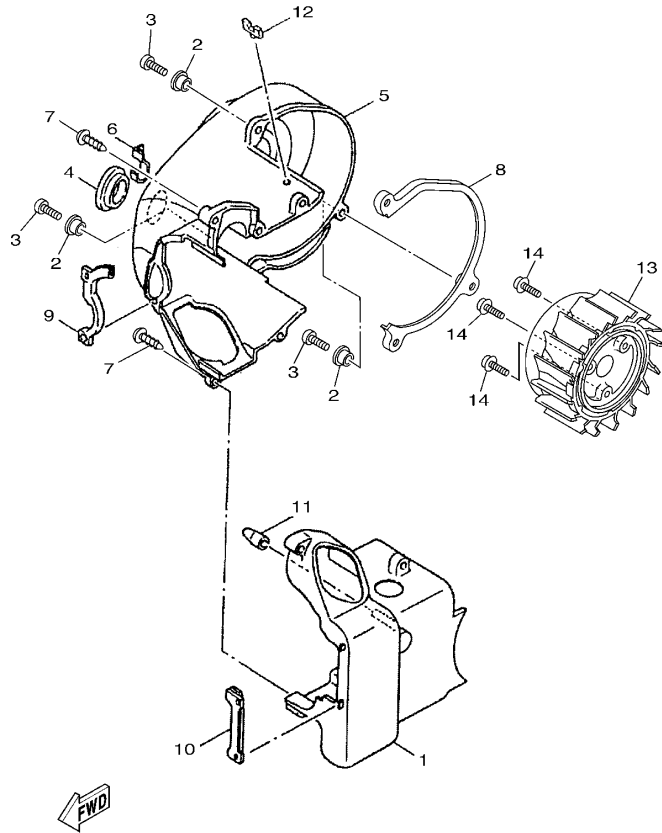

5WB8415-H040

参照 号码	零件号码 PART NO.	零件名称 DESCRIPTION	2, P1				备注 REMARKS
1	5WB-E2651-00	气缸空气罩 1 AIR SHROUD, CYLINDER 1	1				
2	90387-068K5	轴套 COLLAR	3				
3	98502-06020	十字螺钉 SCREW, PAN HEAD	3				
4	90480-30800	橡胶垫 GROMMET	1				
5	5WB-E2652-00	气缸空气罩 2 AIR SHROUD, CYLINDER 2	1				
6	90465-12803	夹箍 CLAMP	1				
7	97702-60530	自攻螺钉 SCREW, TAPPING	5				
8	5WB-E2658-00	冷却风道避震垫 1 DAMPER, AIR SHROUD 1	1				
9	5WB-E2659-00	冷却风道避震垫 2 DAMPER, AIR SHROUD 2	1				
10	5WB-E2668-00	冷却风道避震垫 3 DAMPER, AIR SHROUD 3	1				
11	5WB-E3569-00	绝缘插头 PLUG, BLIND	1				
12	90464-08800	线夹 CLAMP	1				
13	5WB-E2611-01	风扇 FAN	1				
14	90159-06858	带垫螺钉 SCREW, WITH WASHER	3				

FIG. 5 油泵

OIL PUMP

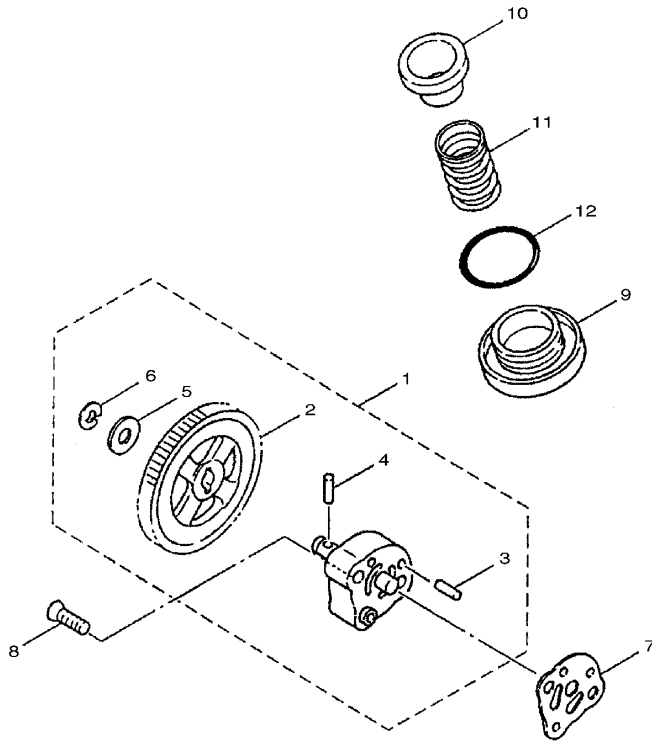

3D31210-D050

参照 号码	零件号码 PART NO.	零件名称 DESCRIPTION	2, P1				备注 REMARKS
1	5WB-E3300-01	机油泵总成 OIL PUMP ASSY	1				
2	5WB-E3325-00	.从动齿轮 .GEAR, PUMP DRIVEN	1				
3	93603-12802	.定位销 .PIN, DOWEL	2				
4	93602-12801	.定位销 .PIN, DOWEL	1				
5	90201-07811	.平垫圈 .WASHER, PLATE	1				
6	99001-05600	.卡环 .CIRCLIP	1				
7	5WB-E3475-00	衬垫 GASKET	1				
8	98702-06020	平头螺钉 SCREW, FLAT HEAD	2				
9	5WB-E5351-00	放油塞 PLUG, DRAIN	1				
10	5WB-E3411-00	机油滤网 STRAINER, OIL	1				
11	90501-16806	压簧 SPRING, COMPRESSION	1				
12	93210-35801	O型环 O-RING	1				

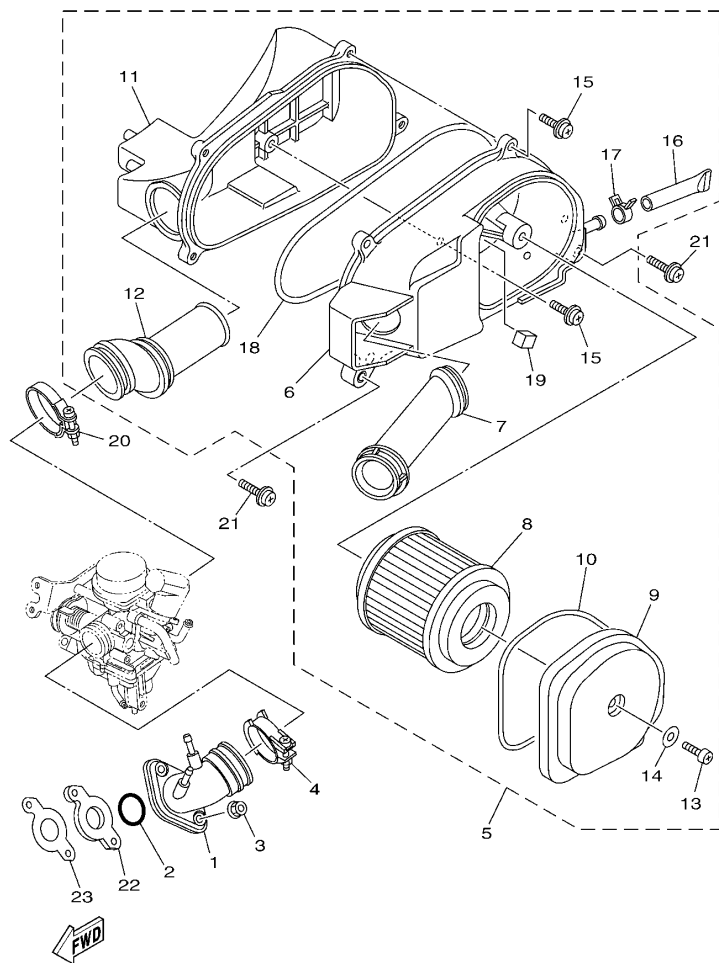

5WB8415-H060

FIG. 6 进气门

INTAKE

参照 号码	零件号码 PART NO.	零件名称 DESCRIPTION	2, P1				备注 REMARKS
1	5WB-E3585-21	岐管 MANIFOLD	1				
2	93210-25809	O型环 O-RING	1				
3	95702-06500	螺母 NUT, FLANGE	2				
4	5WB-E3575-01	箍带 BAND	1				
5	5WB-E4410-13	空气净化器组合 AIR CLEANER ASSY.	1				
6	5WB-E4411-03	空气净化器箱 1 .CASE, AIR CLEANER 1	1				
7	5WB-E4437-00	导管 .DUCT	1				
8	5WB-E4451-01	空气滤芯 .ELEMENT, AIR CLEANER	1				
9	5WB-E4412-00	空气净化器箱盖 1 .CAP, CLEANER CASE 1	1				
10	5WB-E4476-00	密封圈 .SEAL	1				
11	5WB-E4422-02	空气净化器箱盖 2 .CAP, CLEANER CASE 2	1				
12	5WB-E4453-00	空气净化器接头 1 .JOINT, AIR CLEANER 1	1				
13	98502-06025	十字螺钉 .SCREW, PAN HEAD	1				
14	90201-06879	平垫圈 .WASHER, PLATE	1				
15	97602-06225	带垫圈大柱头螺钉 .SCREW, PAN HEAD WITH WASHER	5				
16	5WB-E443E-01	排水管 .PIPE, DRAIN	1				
17	90467-13817	卡环 .CLIP	1				
18	5WB-E4452-00	密封垫 .SEAL	1				
19	5WB-E4457-00	密封垫 .SEAL	1				
20	90450-45803	软管夹组合 HOSE CLAMP ASSY	1				
21	97602-06225	带垫圈大柱头螺钉 SCREW, PAN HEAD WITH WASHER	2				
22	5WB-E3595-00	接头 JOINT	1				
23	5WB-E3556-10	岐管衬垫 GASKET, MANIFOLD	1				

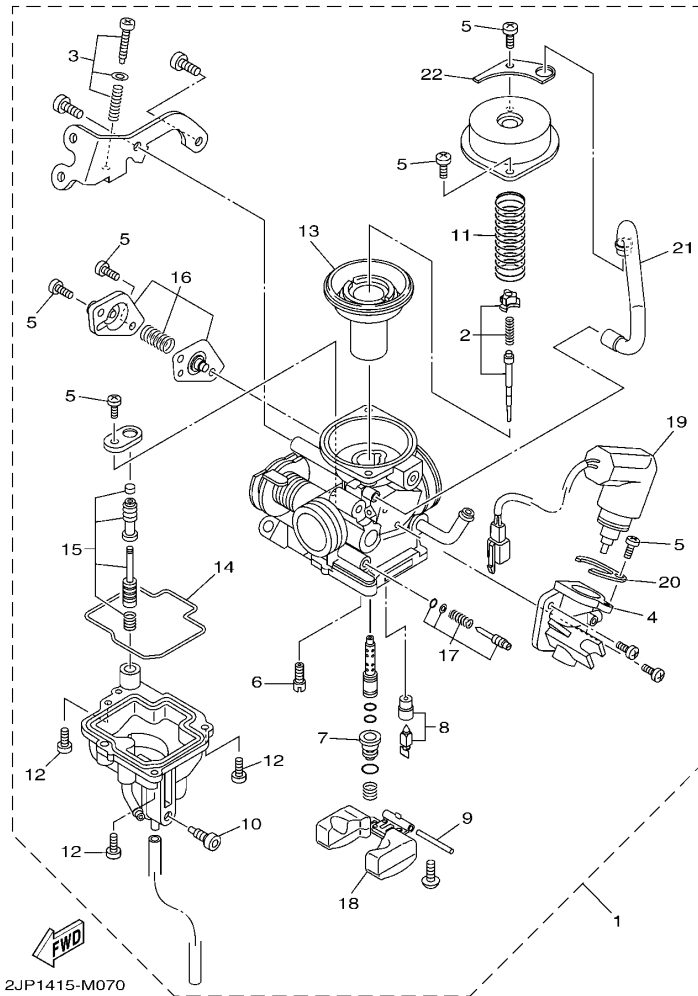

2JP1415-M070

FIG. 7 化油器

CARBURETOR

参照 号码	零件号码 PART NO.	零件名称 DESCRIPTION	2, P1				备注 REMARKS
1	5WB-E4301-50	化油器总成 1 CARBURETOR ASSY 1	1				
2	5WB-E490J-30	.滚针套件 .NEEDLE SET	1				
3	5WB-E490K-10	.止动螺钉套件 .STOP SCREW SET	1				
4	5WB-E4283-11	.化油器盖 1 .COVER, CARBURETOR 1	1				
5	98501-04008	.十字螺钉 .SCREW, PAN HEAD	6				
6	5WB-E4342-16	.低速量孔 (# 32) .JET, PILOT (# 32)	1				
7	5WB-E4343-52	.主量孔 (#104) .JET, MAIN (#104)	1				
8	5WB-E4390-00	.针阀组合 .NEEDLE VALVE ASSY	1				
9	5LB-E4386-00	.浮子销 .PIN, FLOAT	1				
10	5WB-E4115-00	.螺旋 .PLUG, SCREW	1				
11	5WB-E4286-10	.弹簧 .SPRING	1				
12	97601-04014	.带垫十字螺钉 .SCREW, PAN HEAD WITH WASHER	3				
13	5WB-E4340-00	.阀组合 .VALVE ASSY	1				
14	5WB-E4384-10	.浮子室衬垫 .GASKET, FLOAT CHAMBER	1				
15	5WB-E4504-00	.杆套 .ROD SET	1				
16	5WB-E490A-10	.隔膜套件 1 .DIAPHRAGM SET 1	1				
17	5WB-E4105-10	.混合气调整螺钉组件 .PILOT SCREW SET	1				
18	5WB-E4385-10	.浮子 .FLOAT	1				
19	5WB-E4370-11	.柱塞起动机组合 .PLUNGER STARTER ASSY	1				
20	5WB-E4346-00	.面板 .PLATE	1				
21	5WB-E4196-20	.溢流管 1 .PIPE, OVER FLOW 1	1				
22	5WB-E439G-00	.钢夹 1 .CLIP 1	1				

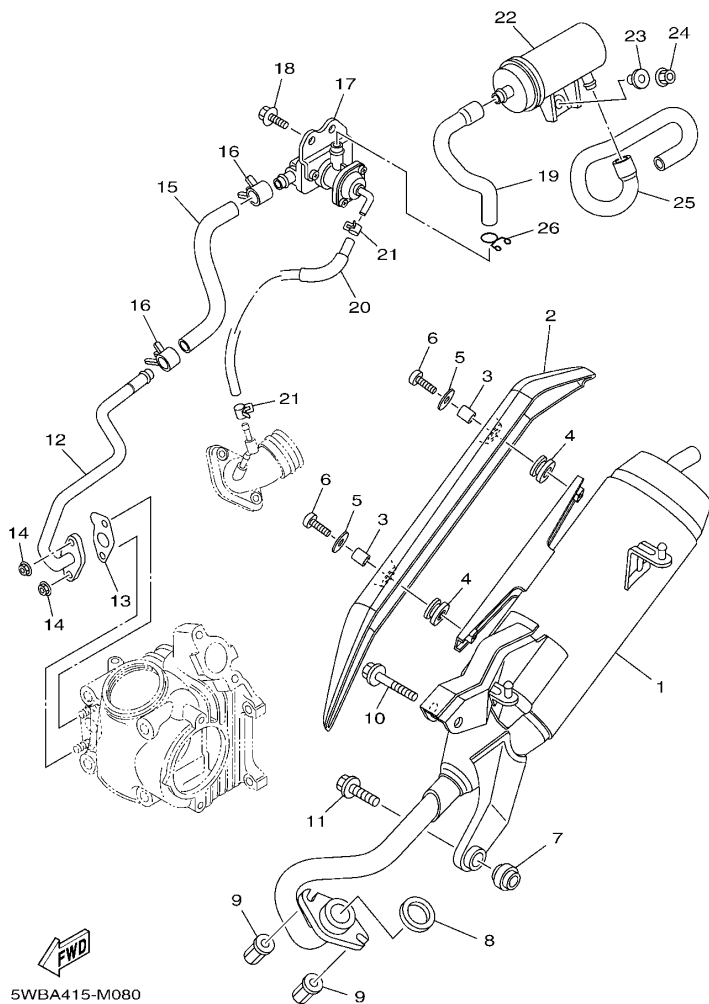
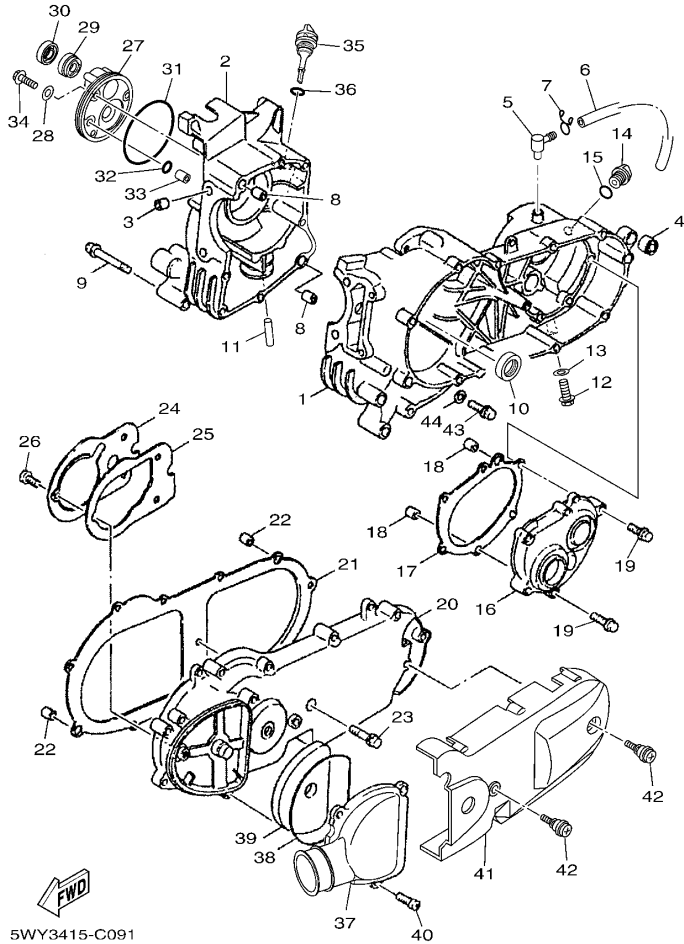

FIG. 8 排气装置

EXHAUST

参照 号码	零件号码 PART NO.	零件名称 DESCRIPTION	2/P1				备注 REMARKS
1	2JP-E4610-00	排气管组合 1 EXHAUST PIPE ASSY 1	1				
2	5WB-E4718-20	消音器保护器 1 PROTECTOR, MUFFLER 1	1				
3	90387-068F6	轴套 COLLAR	2				
4	5WB-E4445-10	固定套 GROMMET	2				
5	90201-06814	平垫圈 WASHER, PLATE	2				
6	98980-06020	螺钉 SCREW, BIND	2				
7	4KL-E4737-00	消音器减震器 DAMPER, MUFFLER	1				
8	5WB-E4613-10	排气管衬垫 GASKET, EXHAUST PIPE	1				
9	90179-06824	螺母 NUT	2				
10	95812-08050	凸缘螺栓 BOLT, FLANGE	1				
11	95812-08030	凸缘螺栓 BOLT, FLANGE	1				
12	5WB-E4872-20	管 2 PIPE 2	1				
13	5WB-E4815-00	衬垫 GASKET	1				
14	95702-06500	螺母 NUT, FLANGE	2				
15	5WB-E4883-11	弯曲软管 3 HOSE, BEND 3	1				
16	90467-16805	卡环 CLIP	2				
17	5WB-E4803-11	二次进气系统 AIR INDUCTION SYSTEM ASSY	1				
18	95802-06012	凸缘螺栓 BOLT, FLANGE	2				
19	5WB-E4884-20	弯曲软管 4 HOSE, BEND 4	1				
20	5WB-E3542-20	负压传感软管 1 HOSE, VACUUM SENSING 1	1				
21	90467-08070	卡环 CLIP	2				
22	4P7-E4806-01	空气滤芯器 AIR FILTER	1				
23	90387-068J2	轴套 COLLAR	1				
24	95702-06500	螺母 NUT, FLANGE	1				
25	5WB-E4885-20	弯曲软管 5 HOSE, BEND 5	1				
26	90467-16808	卡环 CLIP	1				



5WY3415-C091

FIG. 9 曲轴箱

CRANKCASE

参照 号码	零件号码 PART NO.	零件名称 DESCRIPTION	2, P1				备注 REMARKS
1	5WB-E5111-00	曲轴箱 1 CRANKCASE 1	1				
2	5WB-E5121-00	曲轴箱 2 CRANKCASE 2	1				
3	5WB-E5138-00	喷管 1 NOZZLE 1	1				
4	5WB-F2216-00	后减震器衬套 BUSH, REAR SHOCK ABSORBER	1				
5	5WB-E5371-01	通气管接头 BREATHER	1				
6	5WB-E5373-00	通气管 PIPE, BREATHER	1				
7	90467-12814	卡环 CLIP	1				
8	91810-14805	定位销 PIN, DOWEL	2				
9	95022-06070	凸缘螺栓 BOLT, FLANGE	8				
10	93102-22811	油封 OIL SEAL	1				
11	5WB-E3416-00	机油管 1 PIPE, OIL 1	1				
12	95812-08016	凸缘螺栓 BOLT, FLANGE	1				
13	90430-08816	衬垫 GASKET	1				
14	5WB-E5363-00	机油塞 PLUG, OIL	1				
15	93210-14811	O 型环 O-RING	1				
16	5WB-E5421-00	曲轴箱盖 2 COVER, CRANKCASE 2	1				
17	5WB-E5461-00	曲轴箱盖衬垫 2 GASKET, CRANKCASE COVER 2	1				
18	91810-14805	定位销 PIN, DOWEL	2				
19	95022-06030	凸缘螺栓 BOLT, FLANGE	7				
20	5WB-E5411-00	曲轴箱盖 1 COVER, CRANKCASE 1	1				
21	5WB-E5451-00	曲轴箱盖衬垫 1 GASKET, CRANKCASE COVER 1	1				
22	91810-14805	定位销 PIN, DOWEL	2				
23	95022-06035	凸缘螺栓 BOLT, FLANGE	12				
24	5WB-E5191-00	面板 PLATE	1				
25	5WB-E5455-10	衬垫 1 GASKET 1	1				
26	98902-06010	十字槽盘头螺钉 SCREW, BIND	3				
27	5WB-E5417-00	盖 1 COVER, CAP	1				

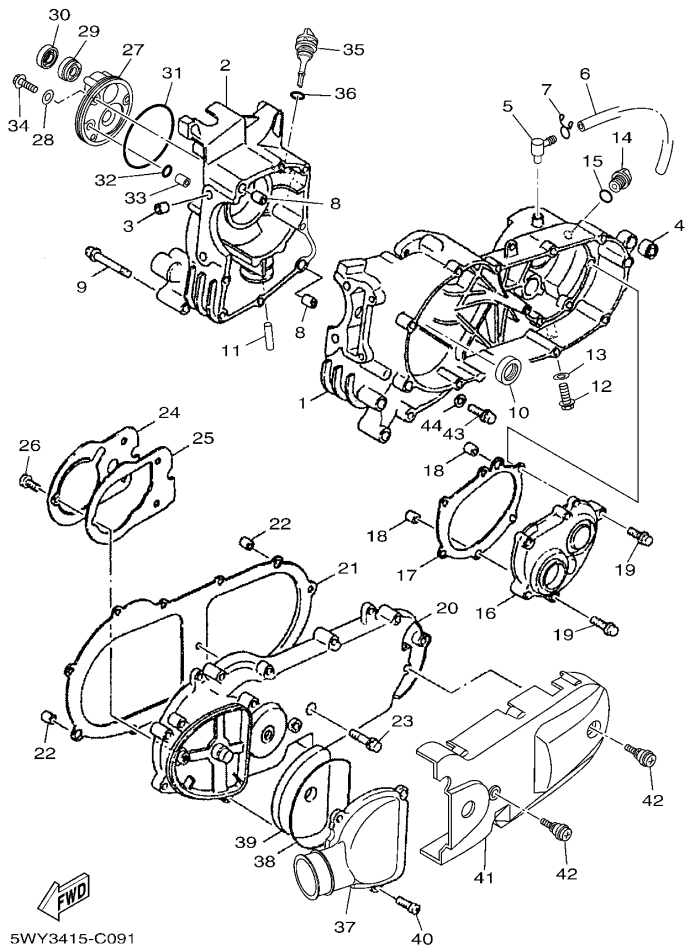

FIG. 9 曲轴箱

CRANKCASE

参照 号码	零件号码 PART NO.	零件名称 DESCRIPTION	2, P1				备注 REMARKS
28	90430-06800	衬垫 GASKET	3				
29	93102-19805	油封 OIL SEAL	1				
30	93102-19008	油封 OIL SEAL	1				
31	93211-02801	0 型环 O-RING	1				
32	93210-07808	0 型环 O-RING	1				
33	91808-12804	定位销 PIN, DOWEL	1				
34	95022-06020	凸缘螺栓 BOLT, FLANGE	3				
35	5WB-E5363-10	机油塞 PLUG, OIL	1				
36	93210-26804	0 型环 O-RING	1				
37	5WB-E5471-01	空气导管 DUCT, AIR	1				
38	5WB-E5472-00	空气导管密封圈 SEAL, AIR DUCT	1				
39	5WB-E5407-00	滤芯 1 ELEMENT 1	1				
40	98902-06020	十字槽盘头螺钉 SCREW, BIND	3				
41	5WB-WE543-00	曲轴箱盖组合 2 CRANKCASE COVER ASSY 2	1				
42	5WB-E5481-01	螺栓 1 BOLT 1	2				
43	90340-12814	螺塞 PLUG, STRAIGHT SCREW	1				
44	90201-12172	平垫圈 WASHER, PLATE	1				

FIG. 10 起动机

STARTER

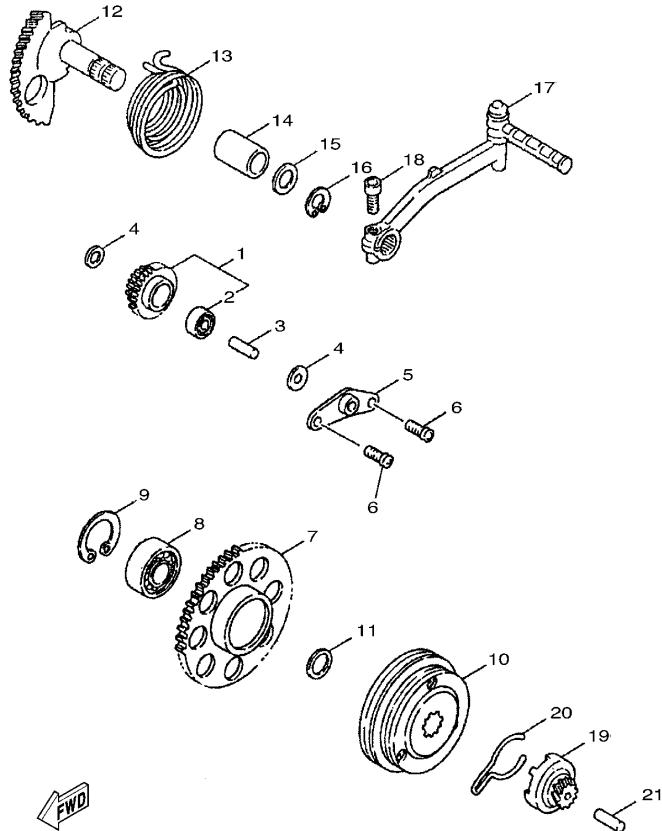

3D31210-D100

参照 号码	零件号码 PART NO.	零件名称 DESCRIPTION	2, P1				备注 REMARKS
1	5WB-E5650-00	中间齿轮组合 IDLE GEAR ASSY	1				
2	93315-110Y6	.轴承 .BEARING	1				
3	5WG-E5521-00	轴 1 SHAFT 1	1				
4	90201-10825	平垫圈 WASHER, PLATE	2				
5	5MH-E5532-00	惰齿轮面板 PLATE, IDLE GEAR	1				
6	98502-06012	十字螺钉 SCREW, PAN HEAD	2				
7	5WB-E5524-00	起动机齿轮 WHEEL, STARTER	1				
8	93306-003YK	轴承 BEARING	1				
9	93450-35826	卡环 CIRCLIP	1				
10	5WB-E5570-01	起动离合器组合 STARTER CLUTCH ASSY	1				
11	90387-16806	轴套 COLLAR	1				
12	5WB-E5601-11	起动机轴组合 KICK SHAFT ASSY	1				
13	90508-32804	扭簧 SPRING, TORSION	1				
14	90380-15806	固体套管 BUSH, SOLID	1				
15	90201-15838	平垫圈 WASHER, PLATE	1				
16	99009-15400	卡环 CIRCLIP	1				
17	5WB-E5620-02	起动机曲柄组合 KICK CRANK ASSY	1				
18	91312-06025	螺栓 BOLT	1				
19	5WB-E5630-00	起动机小齿轮组合 KICK PINION ASSY	1				
20	5WB-E5673-00	钢夹 CLIP	1				
21	5WB-E5659-00	轴 SHAFT	1				

FIG. 11 离合器

CLUTCH

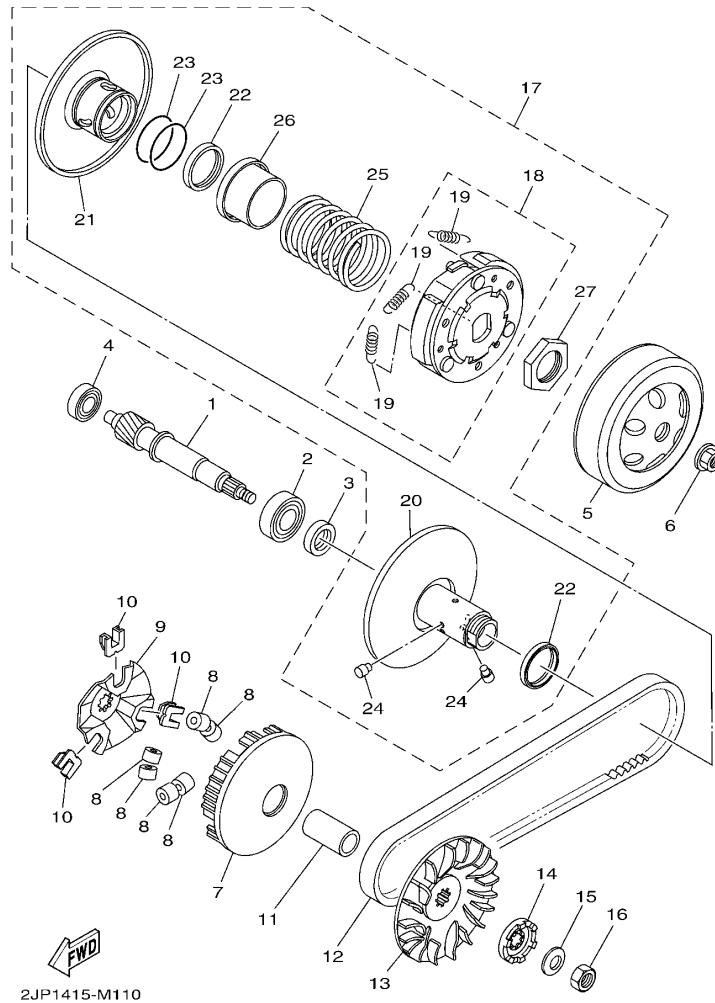

2JP1415-M110

参照 号码	零件号码 PART NO.	零件名称 DESCRIPTION	2/P1				备注 REMARKS
1	5WB-E6111-00	初级驱动齿轮 GEAR, PRIMARY DRIVE	1				
2	93306-203XE	轴承 BEARING	1				
3	93102-17808	油封 OIL SEAL	1				
4	93306-200Y5	轴承 BEARING	1				
5	5WB-E6611-11	离合器壳体组合 CLUTCH HOUSING COMP.	1				
6	90179-10817	螺母 NUT	1				
7	5WB-E7620-10	主滑轮组合 PRIMARY SLIDING SHEAVE COMP.	1				
8	5WB-E7632-31	重锤 WEIGHT	6				
9	5WB-E7623-10	凸轮 CAM	1				
10	5WB-E7653-10	滑块 SLIDER	3				
11	90387-16816	轴套 COLLAR	1				
12	5WB-E7641-00	V型皮带 V-BELT	1				
13	5WB-E7611-20	主固定槽 SHEAVE, PRIMARY FIXED	1				
14	5WB-E5657-00	单向离合器 CLUTCH, ONEWAY	1				
15	90208-12804	弹性挡圈 WASHER, CONICAL SPRING	1				
16	95302-12700	螺母 NUT	1				
17	5WB-E7602-20	副滑轮组合 SECONDARY SHEAVE ASSY	1				
18	5WB-E6620-20	离合器载架组合 CLUTCH CARRIER ASSY	1				
19	5WB-E6626-20	离合器重锤弹簧 1 SPRING, CLUTCH WEIGHT 1	3				
20	5WB-E7660-10	副固定槽滑轮组合 SECONDARY FIXED SHEAVE COMP.	1				
21	5WB-E7670-10	副滑轮 SECONDARY SLIDING SHEAVE	1				
22	93109-33802	油封 OIL SEAL	2				
23	93210-36800	O型环 O-RING	2				
24	5WB-E7664-10	导承销 PIN, GUIDE	2				
25	90501-43804	压簧 SPRING, COMPRESSION	1				
26	5WB-E7684-10	辅助弹簧座 SEAT, SECONDARY SPRING	1				
27	90170-28802	螺母 NUT	1				

FIG. 12 传动

TRANSMISSION

参照 号码	零件号码 PART NO.	零件名称 DESCRIPTION	2, P1				备注 REMARKS
1	5WB-E7410-00	主轮轴组 MAIN AXLE COMP. (47T)	1				
2	93311-315Y8	轴承 BEARING	1				
3	93306-200Y5	轴承 BEARING	1				
4	90201-15816	平垫圈 WASHER, PLATE	1				
5	5WB-E7421-00	驱动轴 AXLE, DRIVE	1				
6	5WB-E7211-00	一档从动齿轮 GEAR, 1ST WHEEL (39T)	1				
7	90208-21802	弹性挡圈 WASHER, CONICAL SPRING	1				
8	93410-20823	卡环 CIRCLIP	1				
9	93306-204YJ	轴承 BEARING	1				
10	93102-26803	油封 OIL SEAL	1				
11	93306-203XE	轴承 BEARING	1				

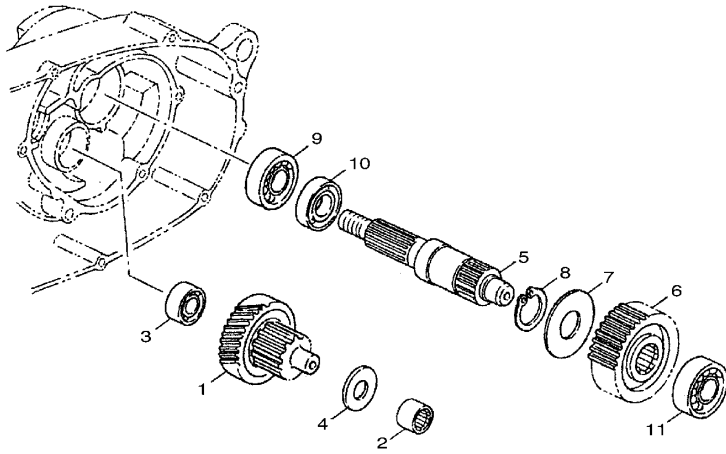

3D31210-D120

FIG. 13 车架

FRAME

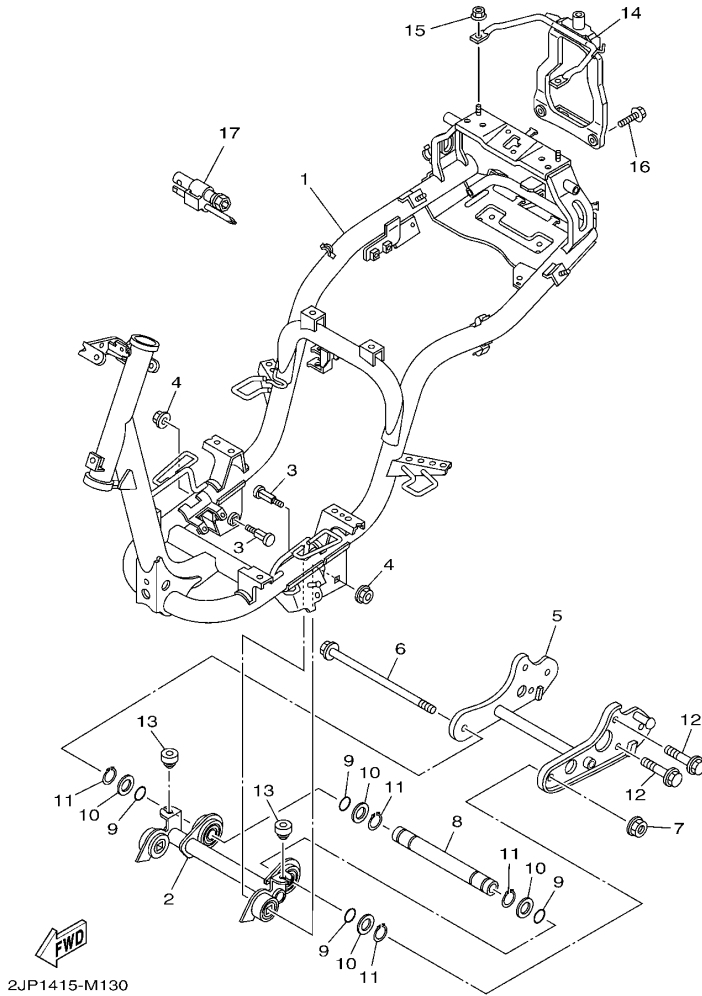

2JP1415-M130

参照 号码	零件号码 PART NO.	零件名称 DESCRIPTION	2/P1				备注 REMARKS
1	2JP-F1110-00	车架组合 FRAME COMP.	1				
2	5WB-F1420-00	发动机托架组 2 ENGINE BRACKET COMP. 2	1				
3	5WB-F1481-01	发动机装配螺栓 1 BOLT, ENGINE MOUNTING 1	2				
4	95602-10200	自锁螺母 NUT, U FLANGE	2				
5	5WB-F1410-00	发动机托架组合 ENGINE BRACKET COMP.	1				
6	90105-10862	凸缘螺栓 BOLT, FLANGE	1				
7	95602-10200	自锁螺母 NUT, U FLANGE	1				
8	5WB-F1459-01	衬套 SPACER	1				
9	93210-15639	O型环 O-RING	4				
10	90201-17485	平垫圈 WASHER, PLATE	4				
11	99009-17400	卡环 CIRCLIP	4				
12	95802-10030	凸缘螺栓 BOLT, FLANGE	4				
13	5WB-F118W-00	限位板 STOPPER	2				
14	2JP-F1232-00	后加强件 REINFORCEMENT, TAIL	1				
15	95702-06500	螺母 NUT, FLANGE	2				
16	95802-08016	凸缘螺栓 BOLT, FLANGE	2				
17	5WB-F8100-01	随车工具 TOOL KIT	1				

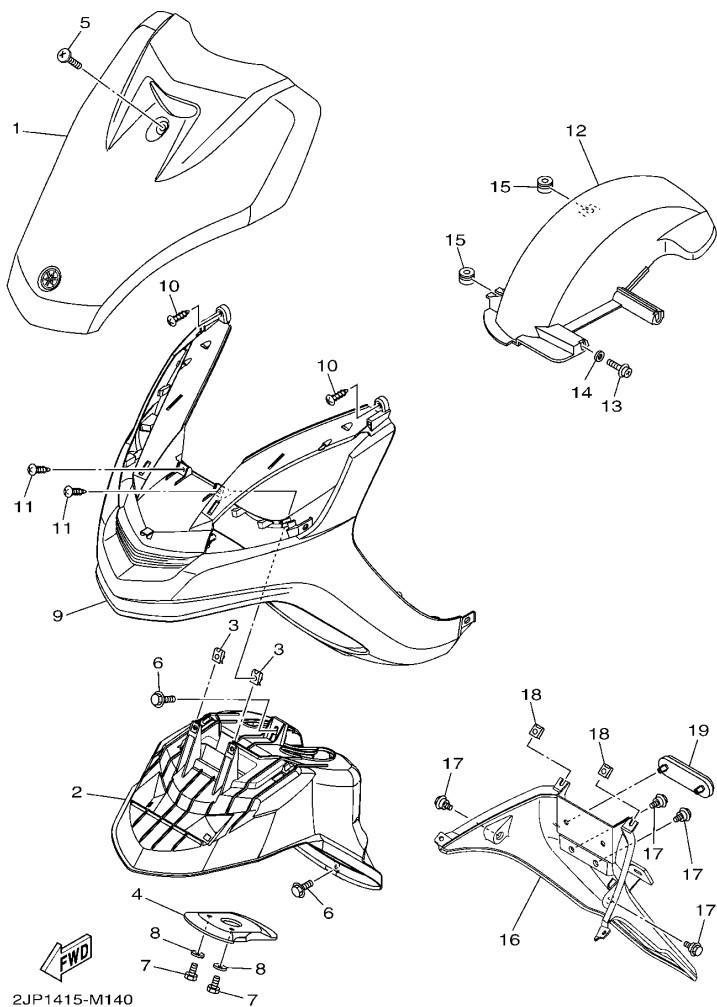
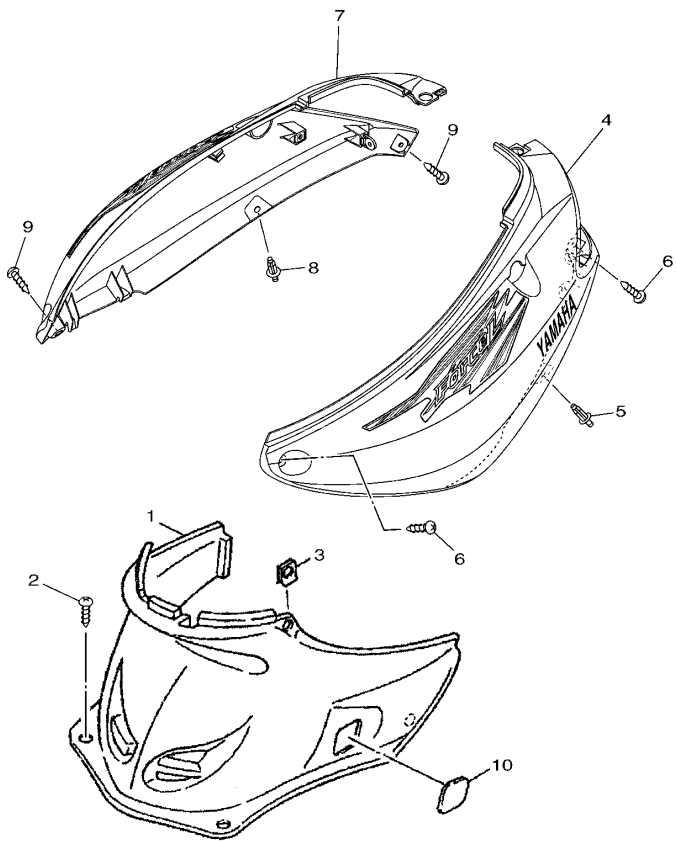

FIG. 14 挡泥板

FENDER

参照 号码	零件号码 PART NO.	零件名称 DESCRIPTION	2, P1				备注 REMARKS
1	2JP-XF151-00-P0	前挡泥板 FENDER, FRONT	1				UR 金属黑色车用 UR FOR SMX
	2JP-XF151-00-P1	前挡泥板 FENDER, FRONT	1				UR 浓红车用 UR FOR DRMK
	2JP-XF151-00-UG	前挡泥板 FENDER, FRONT	1				UR 棕色车用 UR FOR IPB
	2JP-XF151-00-P2	前挡泥板 FENDER, FRONT	1				UR 发紫浅蓝 3 车用 UR FOR PPBM3
2	2JP-F1552-00	内防护板 FENDER, INNER	1				
3	90183-05818	弹性螺母 NUT, SPRING	2				
4	5WB-F1553-00	内防护板 2 FENDER, INNER 2	1				
5	5WB-F8354-00	罩螺钉 1 SCREW, COWLING 1	1				
6	95802-06012	凸缘螺栓 BOLT, FLANGE	2				
7	97002-06016	螺栓 BOLT	2				
8	90201-06850	平垫圈 WASHER, PLATE	2				
9	2JP-F1519-00	防护板嵌条 MOLE, FENDER	1				
10	97702-50016	自攻螺钉 SCREW, TAPPING	2				
11	97702-50012	自攻螺钉 SCREW, TAPPING	2				
12	5WB-F1611-00	后挡泥板 FENDER, REAR	1				
13	90159-06867	带垫螺钉 SCREW, WITH WASHER	1				
14	90387-063F7	轴套 COLLAR	1				
15	90480-12053	橡胶垫 GROMMET	2				
16	2JP-F1685-00	车牌托架 BRACKET, LICENSE	1				
17	90109-06887	螺栓 BOLT	4				
18	90183-05818	弹性螺母 NUT, SPRING	2				
19	1CC-H5130-00	后反射镜组合 REAR REFLECTOR ASSY	1				



2JP1415-M150

FIG. 15 侧盖

SIDE COVER

参照 号码	零件号码 PART NO.	零件名称 DESCRIPTION	2,P1				备注 REMARKS
1	5WB-F1710-00	侧盖组合 1 SIDE COVER ASSY 1	1				
2	97702-50012	自攻螺钉 SCREW, TAPPING	2				
3	90183-05818	弹性螺母 NUT, SPRING	2				
4	2JP-XF173-00-P0	侧盖 3 COVER, SIDE 3	1				UR 金属黑色车用 UR FOR SMX
	2JP-XF173-00-P1	侧盖 3 COVER, SIDE 3	1				UR 浓红车用 UR FOR DRMK
	2JP-XF173-00-UG	侧盖 3 COVER, SIDE 3	1				UR 棕色车用 UR FOR IPB
	2JP-XF173-00-P2	侧盖 3 COVER, SIDE 3	1				UR 发紫浅蓝 3 车用 UR FOR PPBM3
5	90269-06809	铆钉 RIVET	1				
6	97702-50012	自攻螺钉 SCREW, TAPPING	2				
7	2JP-XF174-00-P0	侧盖 4 COVER, SIDE 4	1				UR 金属黑色车用 UR FOR SMX
	2JP-XF174-00-P1	侧盖 4 COVER, SIDE 4	1				UR 浓红车用 UR FOR DRMK
	2JP-XF174-00-UG	侧盖 4 COVER, SIDE 4	1				UR 棕色车用 UR FOR IPB
	2JP-XF174-00-P2	侧盖 4 COVER, SIDE 4	1				UR 发紫浅蓝 3 车用 UR FOR PPBM3
8	90269-06809	铆钉 RIVET	1				
9	97702-50012	自攻螺钉 SCREW, TAPPING	2				
10	5WB-F1875-00	盖 CAP	1				

FIG. 16 后臂·悬挂

REAR ARM & SUSPENSION

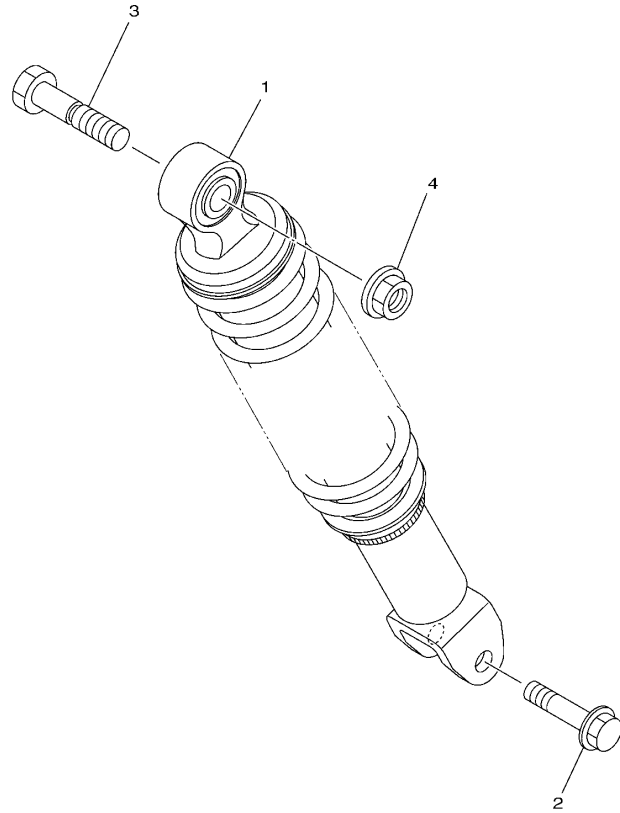

1CC1415-K160

参照 号码	零件号码 PART NO.	零件名称 DESCRIPTION	2/P1				备注 REMARKS
1	5WB-F2210-30	后减震器组合 SHOCK ABSORBER ASSY, REAR	1				
2	90105-08861	凸缘螺栓 BOLT, FLANGE	1				
3	90101-10809	螺栓 BOLT	1				
4	95702-10500	螺母 NUT, FLANGE	1				

FIG. 17 前叉(鼓刹)

FRONT FORK FOR DRUM BRAKE

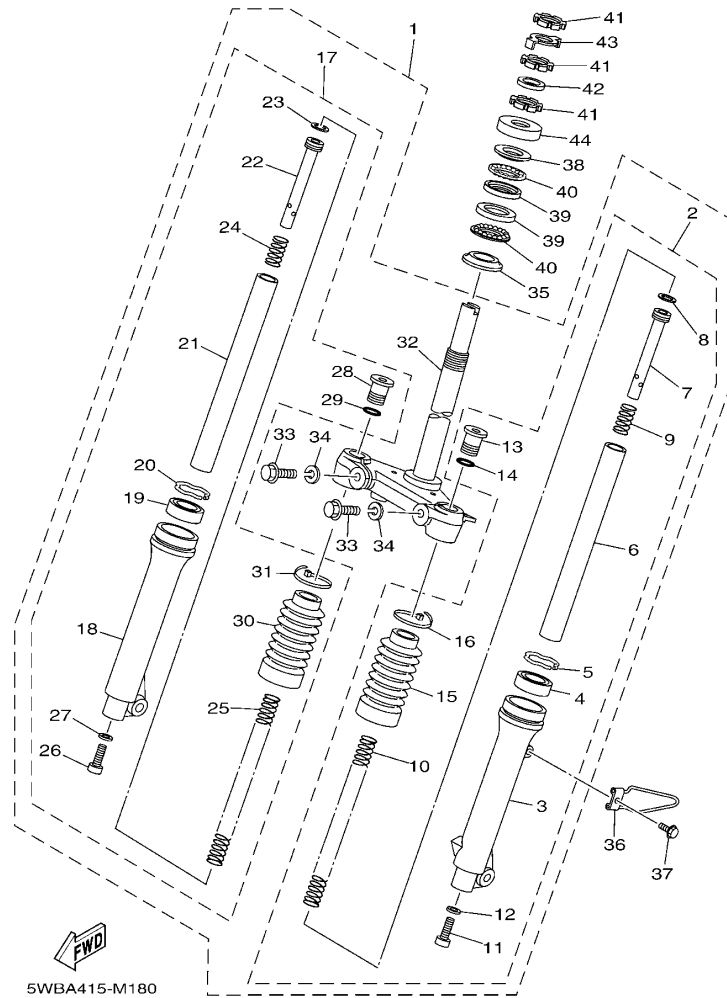

参照 号码	零件号码 PART NO.	零件名称 DESCRIPTION	2.P1				备注 REMARKS
1	5WB-F3100-20	前叉组合 FRONT FORK ASSY	1				
2	5WB-F3102-20	.前叉组合(左边) .FRONT FORK ASSY (L.H)	1				
3	5WB-F3126-20	.外管 1 .TUBE, OUTER (L.H)	1				
4	5WB-F3145-00	.油封 .OIL SEAL	1				
5	5WB-F3156-00	.油封夹 .RING, SNAP	1				
6	5WB-F3110-00	.内管组件 1 .INNER TUBE COMP.1	1				
7	5WB-F3170-00	.前叉气缸组合 .CYLINDER COMP., FRONT FORK	1				
8	5WB-F3157-00	.前叉活塞环 .RING, PISTON	1				
9	5WB-F3152-00	.副弹簧 .SPRING, SUB	1				
10	5WB-F3141-00	.前叉弹簧 .SPRING, FRONT FORK	1				
11	5WB-F3181-01	.内六角头螺栓 .BOLT, HEXAGON SOCKET HEAD	1				
12	5WB-F3158-00	.衬垫 .GASKET	1				
13	4S9-F3356-01	.螺栓 2 .BOLT 2	1				
14	5WB-F3147-00	.O型环 .O-RING	1				
15	5WB-F3191-00	.保护罩 .BOOT	1				
16	5WB-F3192-01	.带箍 .BAND	1				
17	5WB-F3103-20	.前叉组合(右边) .FRONT FORK ASSY (R.H)	1				
18	5WB-F3136-20	.外管 2 .TUBE, OUTER (R.H)	1				
19	5WB-F3145-00	.油封 .OIL SEAL	1				
20	5WB-F3156-00	.油封夹 .RING, SNAP	1				
21	5WB-F3110-00	.内管组件 1 .INNER TUBE COMP.1	1				
22	5WB-F3170-00	.前叉气缸组合 .CYLINDER COMP., FRONT FORK	1				
23	5WB-F3157-00	.前叉活塞环 .RING, PISTON	1				
24	5WB-F3152-00	.副弹簧 .SPRING, SUB	1				
25	5WB-F3141-00	.前叉弹簧 .SPRING, FRONT FORK	1				
26	5WB-F3181-01	.内六角头螺栓 .BOLT, HEXAGON SOCKET HEAD	1				
27	5WB-F3158-00	.衬垫 .GASKET	1				

FIG. 17 前叉(鼓刹)

FRONT FORK FOR DRUM BRAKE

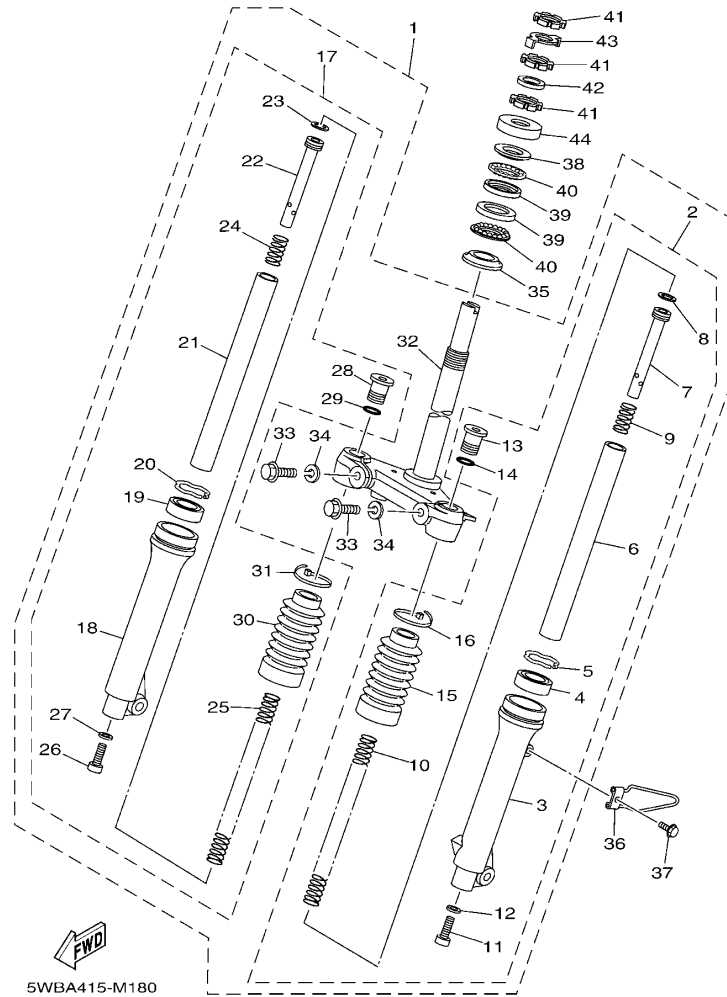

5WBA415-M180

参照 号码	零件号码 PART NO.	零件名称 DESCRIPTION	2, P1				备注 REMARKS
28	4S9-F3356-01	. 螺栓 2 .BOLT 2	1				
29	5WB-F3147-00	. O 型环 .O-RING	1				
30	5WB-F3191-00	. 保护罩 .BOOT	1				
31	5WB-F3192-01	. 带箍 .BAND	1				
32	5WB-F3340-01	. 底托架组 .UNDER BRACKET COMP.	1				
33	5WB-F3346-01	. 螺栓 1 .BOLT 1	2				
34	5WB-F3149-00	. 弹簧上侧垫 .WASHER, SPRING UPPER	2				
35	5WB-F3413-00	滚珠座圈 3 RACE, BALL 3	1				
36	5WB-F3317-01	钢索支架 HOLDER, CABLE	1				
37	95802-06010	凸缘螺栓 BOLT, FLANGE	1				
38	5WB-F3411-00	滚珠座圈 1 RACE, BALL 1	1				
39	5WB-F3412-00	滚珠座圈 2 RACE, BALL 2	2				
40	5WB-F341E-00	保持架 RETAINER, BALL BEARING	2				
41	90179-25810	螺母 NUT	3				
42	90202-26142	平垫圈 WASHER, PLATE	1				
43	5WB-F3418-01	专用垫圈 WASHER, SPECIAL	1				
44	5WB-F3416-01	滚珠座圈盖 2 COVER, BALL RACE 2	1				

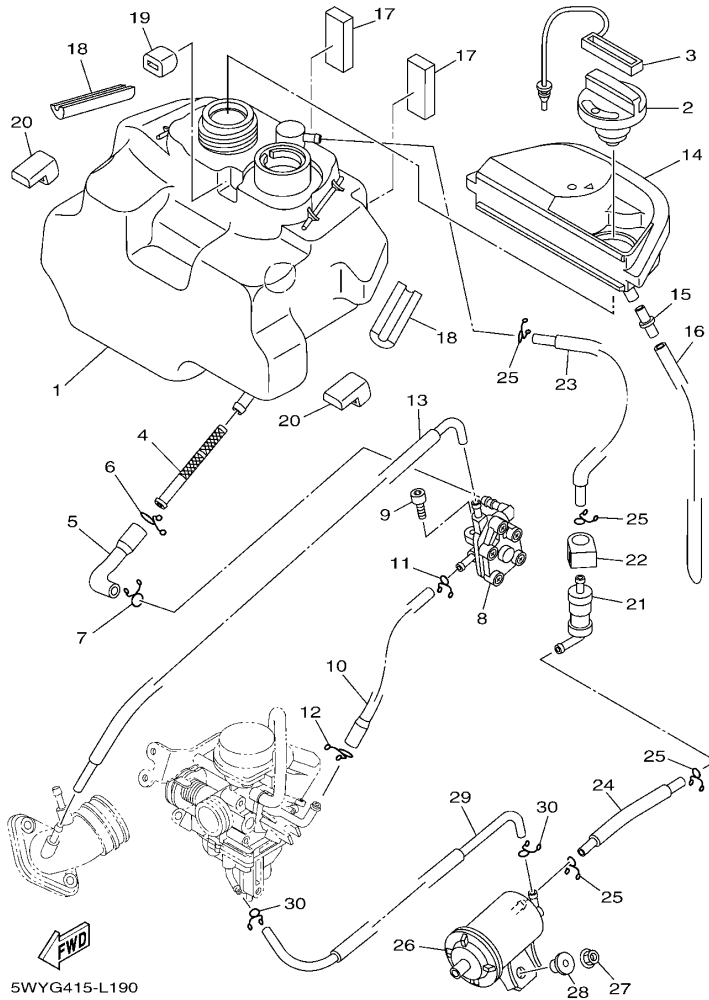

FIG. 18 油箱

FUEL TANK

参照 号码	零件号码 PART NO.	零件名称 DESCRIPTION	2, P1			备注 REMARKS
1	5WB-F4110-10	油箱组合 FUEL TANK COMP.	1			
2	5WB-F4610-10	油箱盖总成 CAP ASSY	1			
3	5WY-F4633-00	滚珠链 CHAIN, BALL	1			
4	5WB-F4560-00	过滤器组合 FILTER ASSY	1			
5	5WB-F4311-01	燃油管 1 PIPE, FUEL 1	1			
6	90467-12802	卡环 CLIP	1			
7	90467-10803	卡环 CLIP	1			
8	5WB-F4500-02	燃油开关组合 1 FUEL COCK ASSY 1	1			
9	91312-06014	螺栓 BOLT	1			
10	5WB-F4312-01	管 2 PIPE 2	1			
11	90467-09006	卡环 CLIP	1			
12	90467-10803	卡环 CLIP	1			
13	5WB-F4313-01	管 3 PIPE 3	1			
14	5WB-F414A-02	加油器盖 COVER, FILLER	1			
15	5WB-F1753-00	连接器轴节 BOSS, CONNECTOR	1			
16	91A11-07048	软管 TUBE, FLEXIBLE	1			
17	5WB-F4181-00	定位减震器 1 DAMPER, LOCATING 1	2			
18	5WB-F4182-00	定位减震器 2 DAMPER, LOCATING 2	2			
19	5WB-F4183-00	定位减震器 3 DAMPER, LOCATING 3	1			
20	5WB-F4184-00	定位减震器 4 DAMPER, LOCATING 4	2			
21	18C-F4180-01	滚动阀组合 ROLL OVER VALVE ASSY	1			
22	4S0-F4135-00	夹箍 1 CLAMP 1	1			
23	5WY-F4314-00	管 4 PIPE 4	1			
24	2JP-F4315-00	管 5 PIPE 5	1			
25	90467-09006	卡环 CLIP	4			
26	5WY-F4170-00	过滤器总成 CANISTER ASSY	1			
27	95702-06500	螺母 NUT, FLANGE	1			

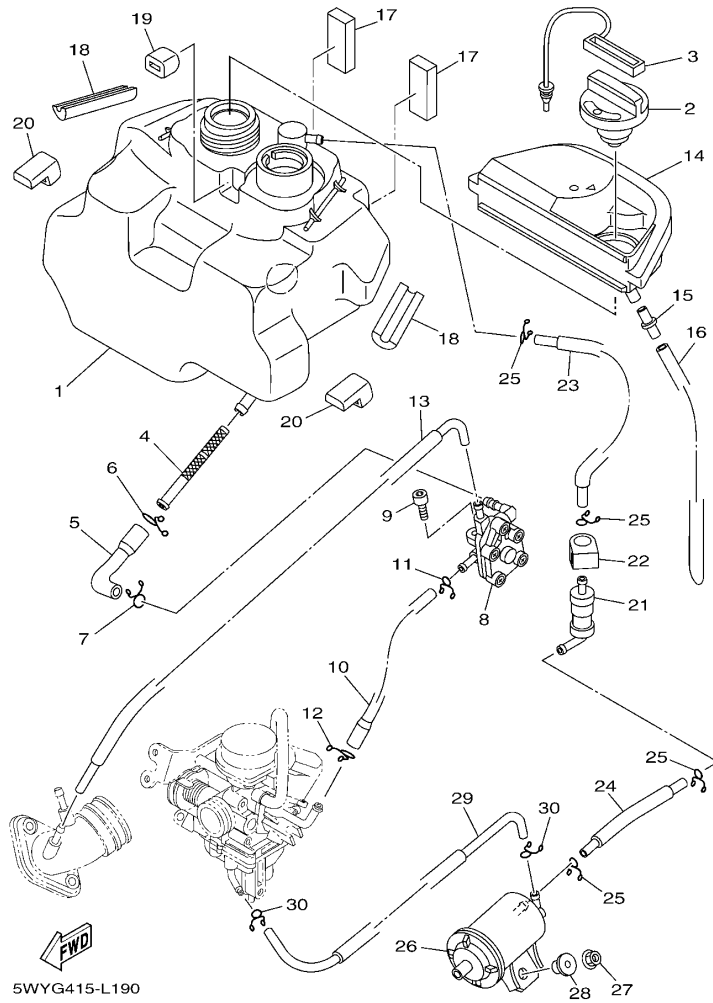

FIG. 18 油箱

FUEL TANK

参照 号码	零件号码 PART NO.	零件名称 DESCRIPTION	2.P1			备注 REMARKS
28	90387-068J2	轴套 COLLAR	1			
29	5WY-F4316-00	管 6 PIPE 6	1			
30	90467-08003	卡环 CLIP	2			

FIG. 19 座位

SEAT

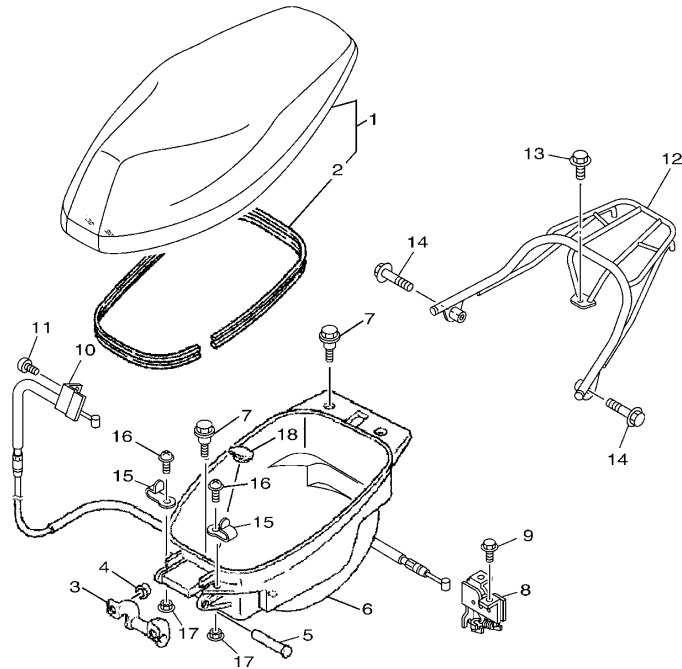

参照 号码	零件号码 PART NO.	零件名称 DESCRIPTION	2, P1				备注 REMARKS
1	2JP-F4730-00	双人座垫组合 DOUBLE SEAT ASSY	1				
2	5WB-F475M-00	.密封圈 .SEAL	1				
3	5WB-F4726-01	座位铰 HINGE, SEAT	1				
4	95702-06500	螺母 NUT, FLANGE	2				
5	5WB-F4727-01	座位装配销 PIN, SEAT FITTING	1				
6	5WB-F473R-00	箱 1 BOX 1	1				
7	90109-06887	螺栓 BOLT	4				
8	5WB-F4780-01	座位锁装置组合 SEAT LOCK ASSY	1				
9	95802-06010	凸缘螺栓 BOLT, FLANGE	2				
10	5WB-F478E-01	车座锁钢索 CABLE, SEAT LOCK	1				
11	98502-05010	十字螺钉 SCREW, PAN HEAD	1				
12	2JP-F4810-00	载架组合 CARRIER ASSY	1				
13	95022-08025	凸缘螺栓 BOLT, FLANGE	1				
14	95022-08045	凸缘螺栓 BOLT, FLANGE	2				
15	5WB-F1398-01	头盔悬挂架 HANGER, HELMET	2				
16	97602-06212	带垫圈大柱头螺钉 SCREW, PAN HEAD WITH WASHER	2				
17	90179-06841	螺母 NUT	2				
18	5WB-F4742-00	塞 GROMMET	1				

2JP1415-M190

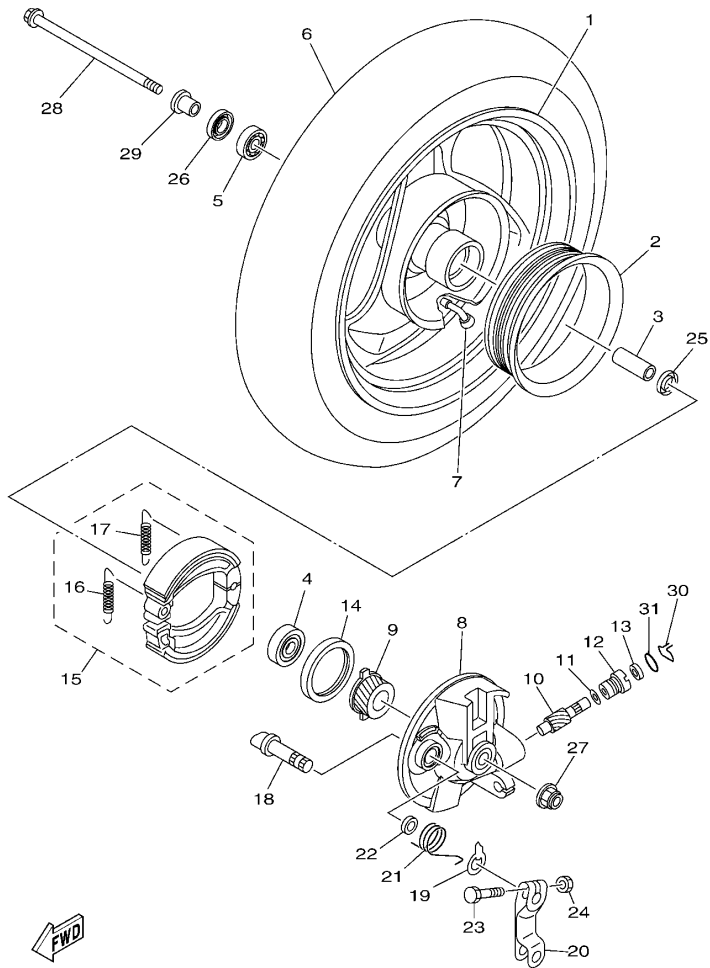

2JP1415-M200

FIG. 20 前轮(鼓刹)

FRONT WHEEL FOR DRUM BRAKE

参照 号码	零件号码 PART NO.	零件名称 DESCRIPTION	2.P1			备注 REMARKS
1	5WY-F5180-00-33	前钣金轮 WHEEL COMP.	1			雅马哈黑色 YB
2	5WY-F5336-00	环 2 RING 2	1			
3	90560-12138	衬套 SPACER	1			
4	93306-301XJ	轴承 BEARING	1			
5	93306-201X4	轴承 BEARING	1			
6	94109-10813	轮胎 TIRE (90/90-10 CY-104 50J TL)	1			CORDIAL
7	93900-00835	气门嘴 VALVE, RIM	1			
8	5WY-F5121-00-33	前制动盖 PLATE, BRAKE SHOE	1			雅马哈黑色 YB
9	5WY-F5135-00	主驱动齿轮 GEAR, DRIVE	1			
10	5WY-F5138-00	仪表齿轮 GEAR, METER	1			
11	90201-07076	平垫圈 WASHER, PLATE	1			
12	4KL-F5136-10	衬套 BUSH	1			
13	93104-07803	油封 OIL SEAL	1			
14	93106-44800	油封 OIL SEAL	1			
15	1CC-X2534-00	制动蹄块组合 BRAKE SHOE SET	1			
16	90506-12001	拉簧 .SPRING, TENSION	1			
17	90506-15001	拉簧 .SPRING, TENSION	1			
18	4S9-F5351-10	凸轮轴 CAMSHAFT	1			
19	4KL-F513A-01	指示器面板 PLATE, INDICATOR	1			
20	5WY-F5155-01	制动臂 1 LEVER, CAMSHAFT 1	1			
21	90508-26801	扭簧 SPRING, TORSION	1			
22	4KL-F5159-00	凸轮轴密封 SEAL, CAMSHAFT	1			
23	90101-06046	螺栓 BOLT	1			
24	95302-06600	螺母 NUT	1			
25	5WG-F5315-00	凸缘衬套 FLANGE, SPACER	1			
26	93106-17806	油封 OIL SEAL	1			
27	95602-12200	自锁螺母 NUT, SELF-LOCKING	1			

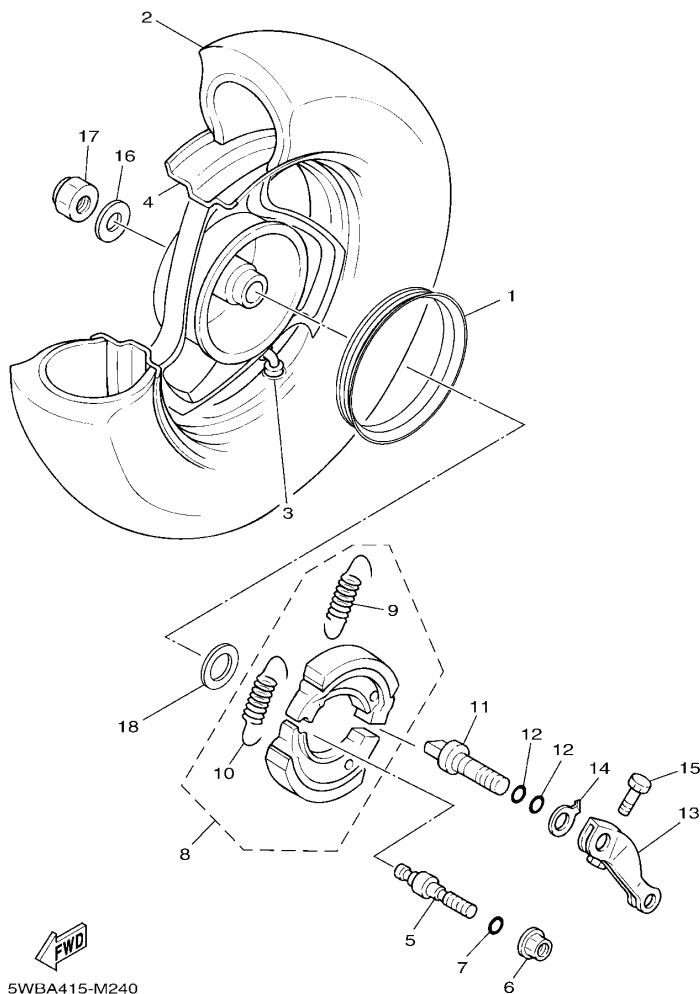

5WBA415-M240

FIG. 21 后轮

REAR WHEEL

参照 号码	零件号码 PART NO.	零件名称 DESCRIPTION	2, P1				备注 REMARKS
1	5WB-F5336-00	环 2 RING 2	1				
2	94109-10813	轮胎 TIRE (90/90-10 CY-104 50J TL)	1				CORDIAL
3	93900-00835	气门嘴 VALVE, RIM	1				
4	5WB-F5390-10-33	后轮组 REAR WHEEL COMP.	1				雅马哈黑色 YB
5	5WB-F5326-01	枢轴 PIN, PIVOT	1				
6	95702-10500	螺母 NUT, FLANGE	1				
7	93210-07890	O 型环 O-RING	1				
8	5WB-XF253-01	制动蹄块套件 BRAKE SHOE SET	1				
9	90506-12001	拉簧 .SPRING, TENSION	1				
10	90506-15001	拉簧 .SPRING, TENSION	1				
11	5WB-F5351-01	凸轮轴 CAMSHAFT	1				
12	93210-09859	O 型环 O-RING	2				
13	5WB-F5355-01	制动臂 1 LEVER, CAMSHAFT	1				
14	5WB-F533A-01	指示片 PLATE, INDICATOR	1				
15	90101-06818	螺栓 BOLT	1				
16	90201-14810	平垫圈 WASHER, PLATE	1				
17	90185-14807	自锁螺母 NUT, SELF-LOCKING	1				
18	90201-203E7	平垫圈 WASHER, PLATE	1				

FIG. 22 操纵手柄 钢索(鼓刹)

STEERING CABLE FOR DRUM BRAKE

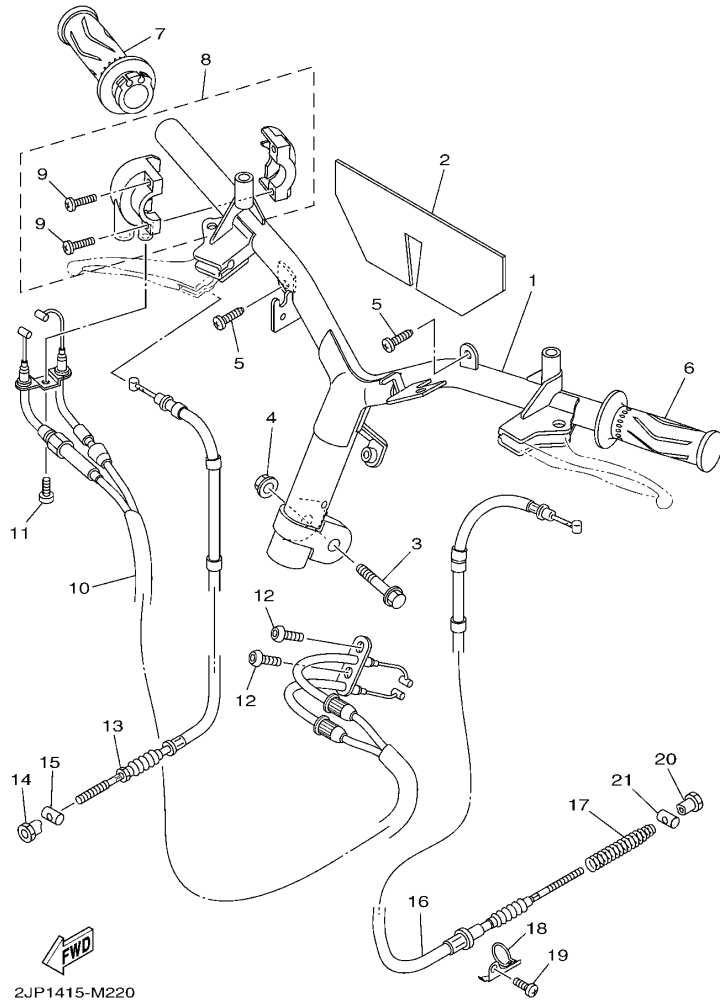

参照 号码	零件号码 PART NO.	零件名称 DESCRIPTION	2, P1				备注 REMARKS
1	5WB-F6110-20	手柄组件 HANDLE COMP.	1				
2	5WB-F6113-00	减震垫 DAMPER	1				
3	90105-10036	凸缘螺栓 BOLT, FLANGE	1				
4	95602-10200	自锁螺母 NUT, U FLANGE	1				
5	97702-50016	自攻螺钉 SCREW, TAPPING	2				
6	2JP-F6241-00	握把(左边) GRIP	1				
7	2JP-F6240-00	握把(右边) GRIP ASSY	1				
8	4P7-F6270-01	钢索连接器盖组合 CAP GRIP ASSY	1				
9	98502-05020	十字螺钉 SCREW, PAN HEAD	2				
10	5WB-F6301-00	油门钢索组合 THROTTLE CABLE ASSY	1				
11	98502-05010	十字螺钉 SCREW, PAN HEAD	1				
12	92012-05010	螺钉 BOLT, BUTTON HEAD	2				
13	5WB-F6341-00	制动拉索 1 WIRE, BRAKE 1	1				
14	90179-06843	螺母 NUT	1				
15	90249-12008	销 PIN	1				
16	5WB-F6351-01	制动器钢索 CABLE, BRAKE	1				
17	5WB-F6314-00	弹簧 SPRING	1				
18	5WB-F637G-01	钢索支架 HOLDER, WIRE	1				
19	98502-06012	十字螺钉 SCREW, PAN HEAD	1				
20	90179-06843	螺母 NUT	1				
21	90249-12008	销 PIN	1				

FIG. 23 搁脚·支架

STAND & FOOTREST

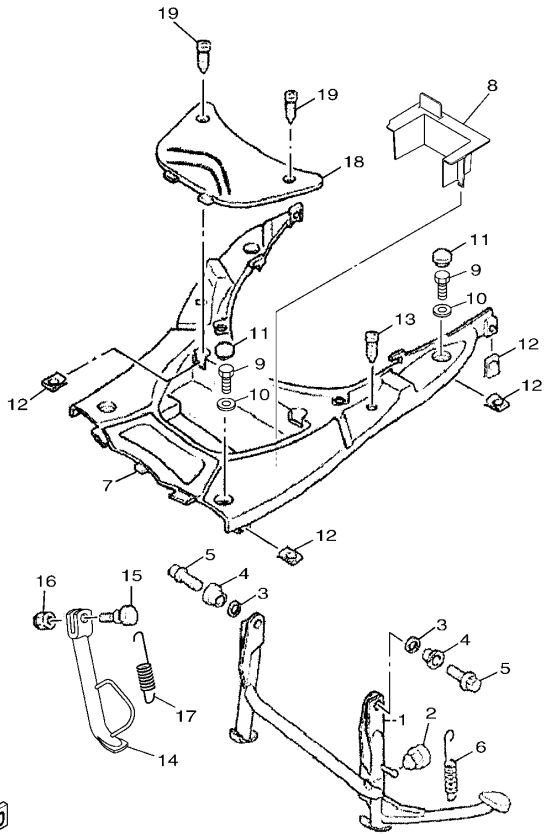

2JP1415-M230

参照 号码	零件号码 PART NO.	零件名称 DESCRIPTION	2/P1				备注 REMARKS
1	5WB-F7111-00	主支承 STAND, MAIN	1				
2	5WB-F7114-00	主支承限位板 STOPPER, MAIN STAND	1				
3	90202-15804	平垫圈 WASHER, PLATE	2				
4	5WB-F7113-01	主支承安装 COLLAR, MAIN STAND	2				
5	95822-10035	凸缘螺栓 BOLT, FLANGE	2				
6	5WB-F7116-00	主支承弹簧 SPRING, MAIN STAND	1				
7	5WB-F7481-02	搁脚踏板 BOARD, FOOTREST	1				
8	2JP-H252H-00	支架 PLATE, HOLDER	1				
9	97002-06030	螺栓 BOLT	4				
10	90201-06879	平垫圈 WASHER, PLATE	4				
11	5WB-F7475-00	盖 1 CAP 1	4				
12	90183-05818	弹性螺母 NUT, SPRING	8				
13	97702-50016	自攻螺钉 SCREW, TAPPING	2				
14	2JP-F7311-00	侧支承 STAND, SIDE	1				
15	90109-08821	螺栓 BOLT	1				
16	90185-08818	自锁螺母 NUT, SELF-LOCKING	1				
17	5WB-F7316-01	侧支承弹簧 SPRING, SIDE STAND	1				
18	5WB-H2129-00	蓄电池盖 COVER, BATTERY	1				
19	97702-50012	自攻螺钉 SCREW, TAPPING	2				

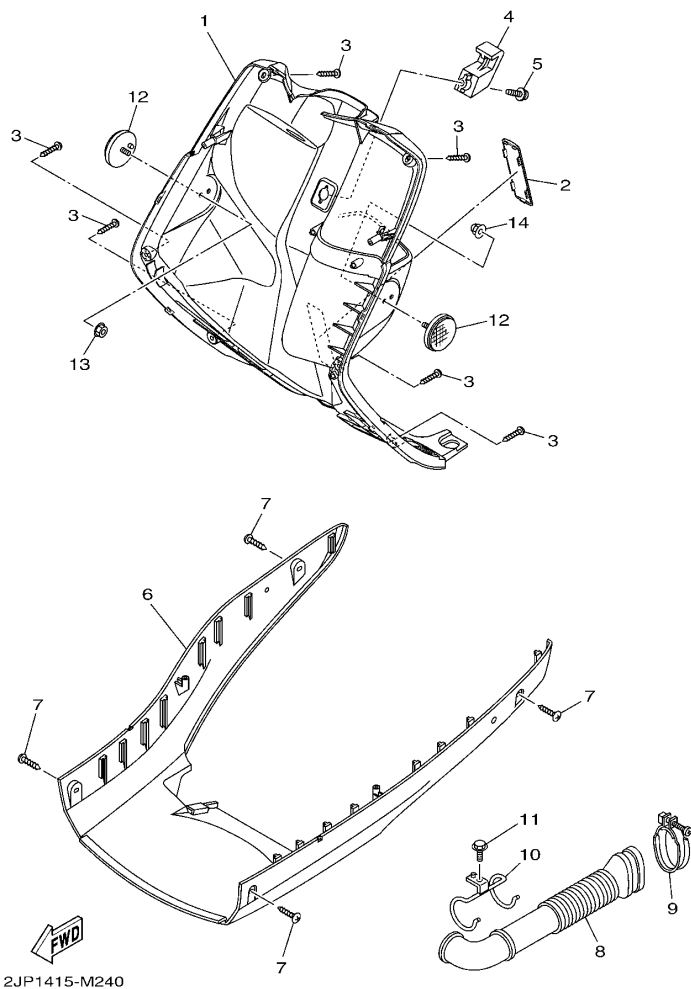

FIG. 24 护腿

LEG SHIELD

参照 号码	零件号码 PART NO.	零件名称 DESCRIPTION	2.P1				备注 REMARKS
1	2JP-F8300-00	护腿装置组合 LEG SHIELD ASSY	1				
2	2JP-F8349-00	盖 CAP	1				
3	97702-50016	自攻螺钉 SCREW, TAPPING	6				
4	5WB-F8257-00	钩 1 HOOK 1	1				
5	90159-06842	带垫螺钉 SCREW, WITH WASHER	1				
6	5WB-F8385-00	下侧盖 COVER, UNDER	1				
7	97702-50016	自攻螺钉 SCREW, TAPPING	4				
8	5WB-F1557-00	空气管道 DUCT, AIR	1				
9	5WB-F1823-01	软管夹 CLAMP, HOSE	1				
10	5WB-F1161-01	钢索支架 HOLDER, CABLE	1				
11	97502-05510	带垫螺栓 BOLT, WITH WASHER	1				
12	2JP-H5141-00	后反射镜 2 REFLECTOR, REAR 2	2				
13	95702-06500	螺母 NUT, FLANGE	1				
14	90176-06802	盖型螺母 NUT, CROWN	1				

FIG. 25 导流罩 1

COWLING 1

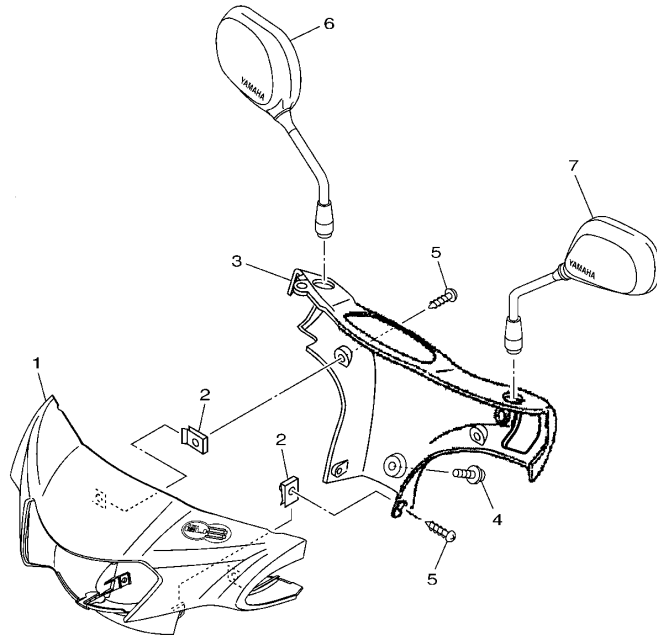

参照 号码	零件号码 PART NO.	零件名称 DESCRIPTION	2.P1				备注 REMARKS
1	2JP-XF614-00-P0	手把杆上侧盖 1 COVER, HANDLE UPPER 1	1				UR 金属黑色车用 UR FOR SMX
	2JP-XF614-00-P1	手把杆上侧盖 1 COVER, HANDLE UPPER 1	1				UR 浓红车用 UR FOR DRMK
	2JP-XF614-00-UG	手把杆上侧盖 1 COVER, HANDLE UPPER 1	1				UR 棕色车用 UR FOR IPB
	2JP-XF614-00-P2	手把杆上侧盖 1 COVER, HANDLE UPPER 1	1				UR 发紫浅蓝 3 车用 UR FOR PPBM3
2	90183-05818	弹性螺母 NUT, SPRING	4				
3	5WB-F6145-20	手把杆上侧盖 2 COVER, HANDLE UPPER 2	1				
4	90159-05812	带垫螺钉 SCREW, WITH WASHER	1				
5	97702-50012	自攻螺钉 SCREW, TAPPING	4				
6	5WY-F6290-40	后视镜组合 (右边) REAR VIEW MIRROR ASSY (RIGHT)	1				
7	5WY-F6280-40	后视镜组合 (左边) REAR VIEW MIRROR ASSY (LEFT)	1				



2JP1415-M250

FIG. 27 起动机

STARTING MOTOR

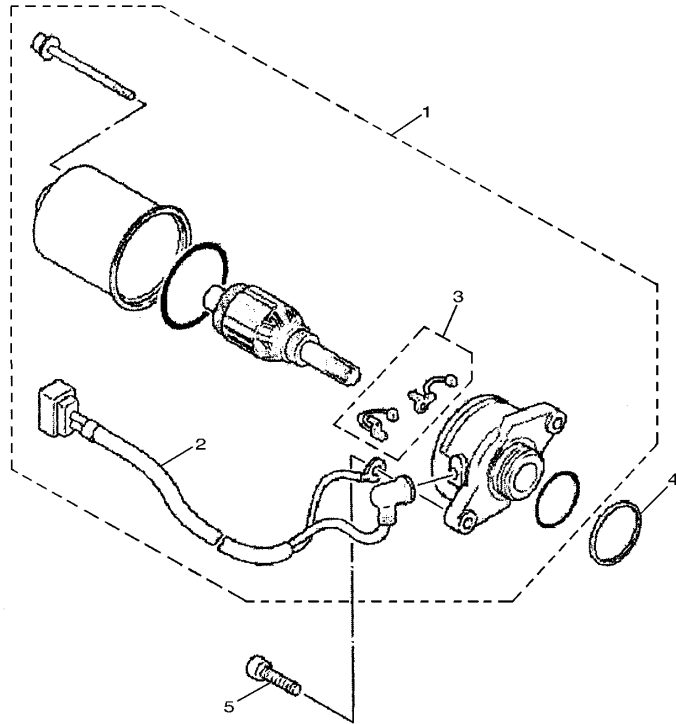

参照 号码	零件号码 PART NO.	零件名称 DESCRIPTION	2, P1				备注 REMARKS
1	5WB-H1800-13	起动机组合 STARTING MOTOR ASSY	1				
2	5WB-H183G-00	. 导线组件 . CORD COMP.	1				
3	5WB-H1801-00	. 碳刷组件 . BRUSH SET	1				
4	90202-26801	平垫圈 WASHER, PLATE	1				
5	91312-06020	螺栓 BOLT	2				

3D31210-D271

FIG. 28 转向灯

FLASHER LIGHT

参照 号码	零件号码 PART NO.	零件名称 DESCRIPTION	2.P1				备注 REMARKS
1	2JP-H3310-00	前转向灯组合 1 FRONT FLASHER LIGHT ASSY 1	1				
2	2JP-H3311-00	. 转向灯灯泡 . BULB, FLASHER (12V-R10W)	1				
3	2JP-H4340-00	. 插座缆索组合 1 . SOCKET CORD ASSY 1	1				
4	2JP-H3320-00	前转向灯组合 2 FRONT FLASHER LIGHT ASSY 2	1				
5	2JP-H3311-00	. 转向灯灯泡 . BULB, FLASHER (12V-R10W)	1				
6	2JP-H4350-00	. 插座缆索组合 2 . SOCKET CORD ASSY 2	1				
7	97702-50016	自攻螺钉 SCREW, TAPPING	6				

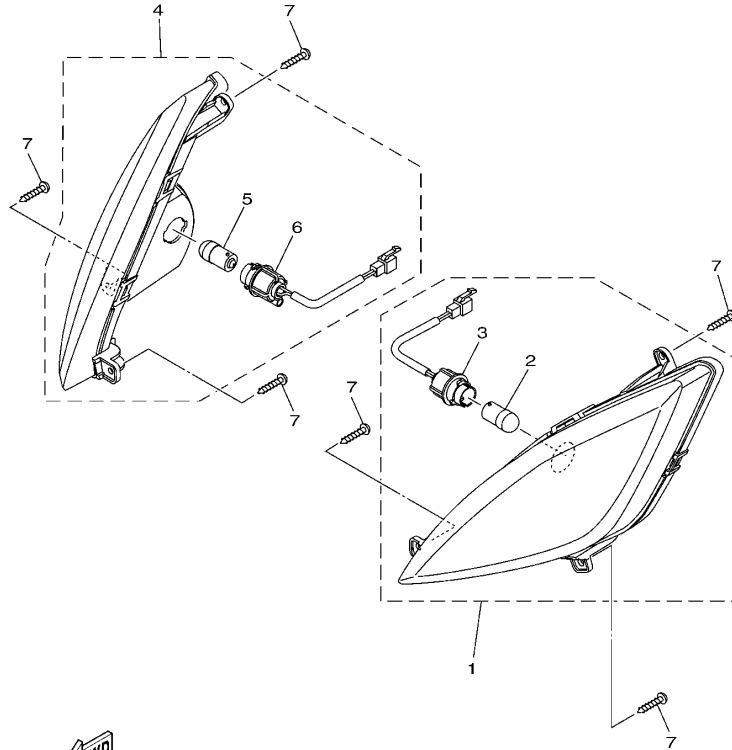

 2JP1415-M280

FIG. 29 仪表

METER

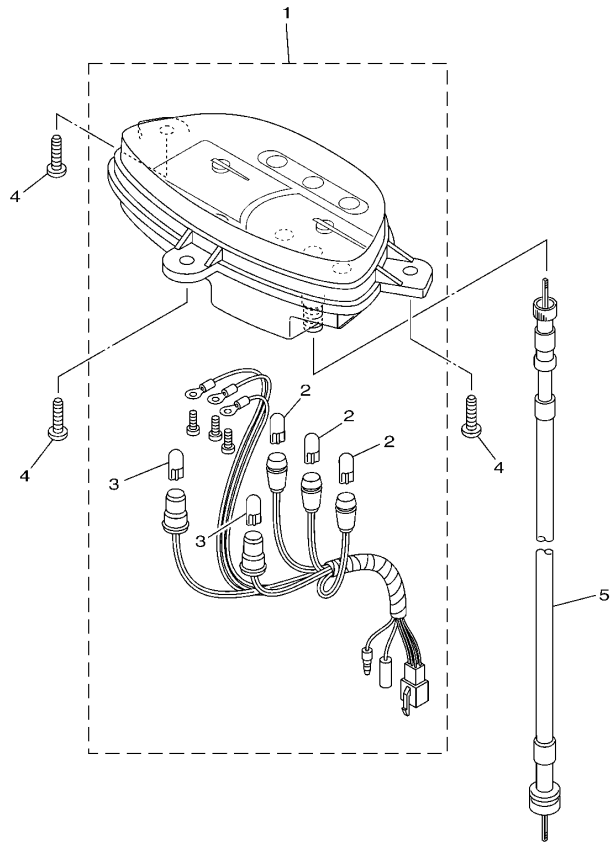

参照 号码	零件号码 PART NO.	零件名称 DESCRIPTION	2.P1				备注 REMARKS
1	5WB-H3510-30	测速计组合 SPEEDOMETER ASSY	1				
2	5WB-H3517-00	.灯泡 .BULB (12V-1.7W)	3				
3	5WB-H3517-10	.灯泡 .BULB (14V-3W)	2				
4	97702-50016	自攻螺钉 SCREW, TAPPING	3				
5	5WB-H3550-10	速度计软轴组合 SPEEDOMETER CABLE ASSY	1				

 2JP1415-M290

FIG. 30 前大灯

HEADLIGHT

参照 号码	零件号码 PART NO.	零件名称 DESCRIPTION	2, P1				备注 REMARKS
1	5WY-H4310-10	大灯组件 HEADLIGHT UNIT ASSY	1				
2	4KL-H4314-00	.前照灯灯泡 .BULB, HEADLIGHT (12V-35/35W)	1				
3	5WY-H4312-10	.导线组合 .CORD ASSY	1				
4	5WY-H4147-00	.导向灯灯泡 .BULB, PILOT LIGHT (12V-3W)	1				
5	5WY-H4146-00	.指示灯座 .SOCKET, PILOT LIGHT	1				
6	90149-05807	螺钉 SCREW	1				

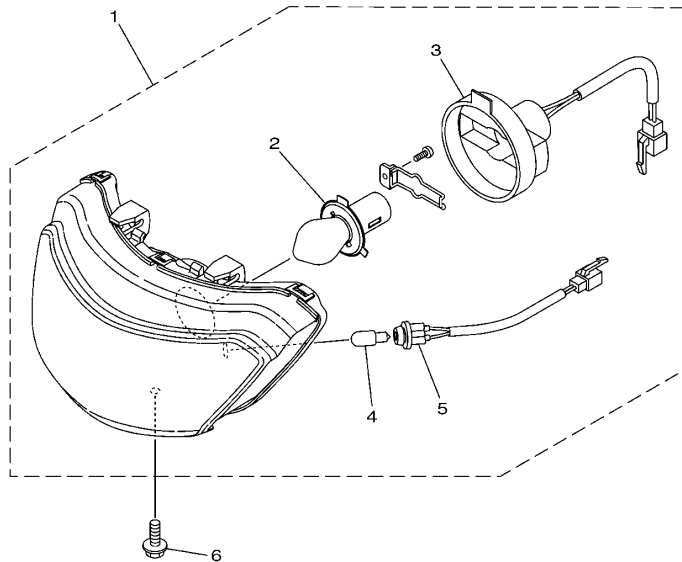

5WYG415-L350

FIG. 31 尾灯

TAILLIGHT

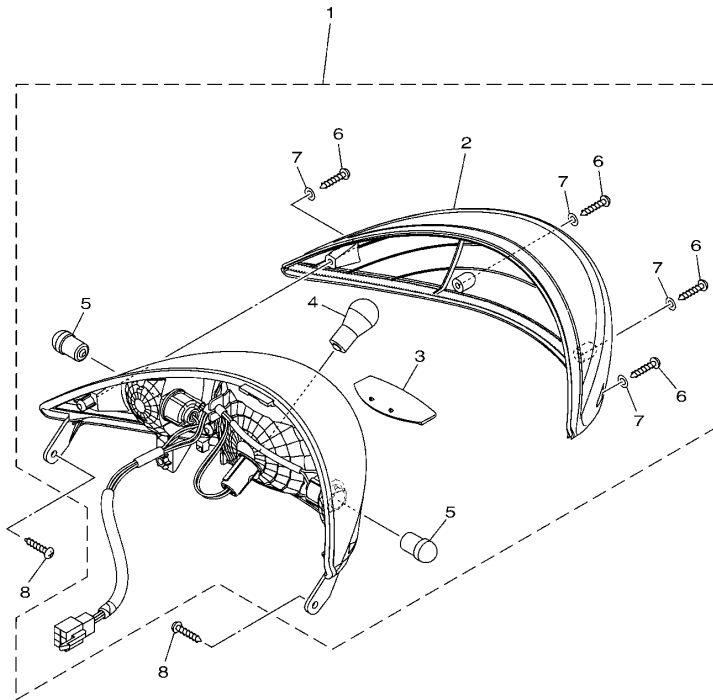

参照 号码	零件号码 PART NO.	零件名称 DESCRIPTION	2.P1				备注 REMARKS
1	5WY-H4700-30	尾灯组合 TAILLIGHT ASSY	1				
2	5WY-H4540-30	镜面组合 .LENS ASSY	1				
3	5WY-H4743-30	牌照灯镜头 .LENS, LICENCE LIGHT	1				
4	4KL-H4714-20	灯泡 (12V-21/5W) .BULB (12V-21/5W)	1				
5	1CC-H3311-10	转向灯灯泡 .BULB, FLASHER (12V-R10W)	2				
6	97707-40612	自攻螺钉 .SCREW, TAPPING	4				
7	5WY-H1894-00	特制垫 .WASHER, SPECIAL	4				
8	97702-50012	自攻螺钉 SCREW, TAPPING	2				

FIG. 32 手柄开关(鼓刹)

SWITCH & LEVER FOR DRUM BRAKE

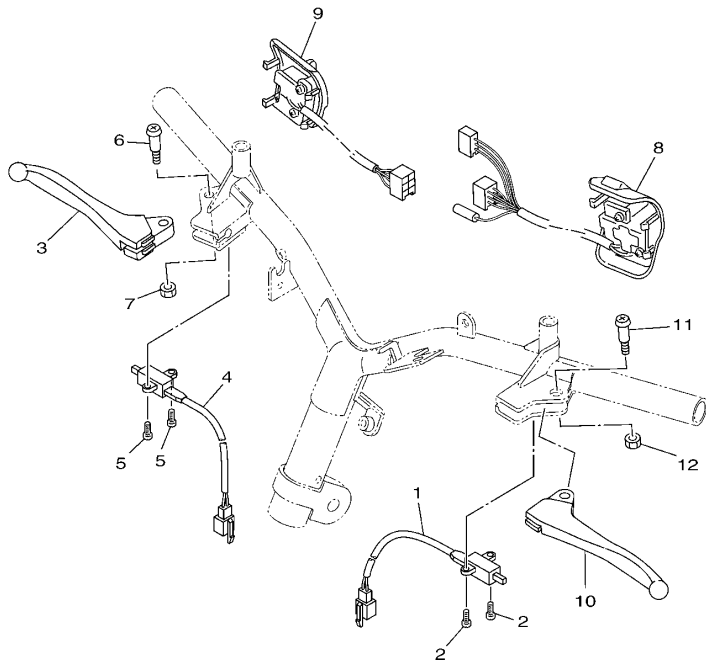

参照 号码	零件号码 PART NO.	零件名称 DESCRIPTION	2, P1				备注 REMARKS
1	5WB-H3980-01	前制动开关组合 FRONT STOP SWITCH ASSY	1				
2	98502-03005	十字螺钉 SCREW, PAN HEAD	2				
3	5WY-H3922-10	手柄 2 LEVER 2	1				
4	5WB-H3980-01	前制动开关组合 FRONT STOP SWITCH ASSY	1				
5	98502-03005	十字螺钉 SCREW, PAN HEAD	2				
6	5WB-H3945-00	杠杆螺钉 BOLT, LEVER	1				
7	95602-05100	锁紧螺母 NUT, U	1				
8	5WY-H3963-11	手把开关 3 (右边) SWITCH, HANDLE 3	1				
9	4S0-H3975-01	手把开关 2 SWITCH, HANDLE 2	1				
10	5WB-H3912-10	手柄 1 LEVER 1	1				
11	5WB-H3945-00	杠杆螺钉 BOLT, LEVER	1				
12	95602-05100	锁紧螺母 NUT, U	1				

FWD
5WBA415-M380

FIG. 33 电气系统 1

ELECTRICAL 1

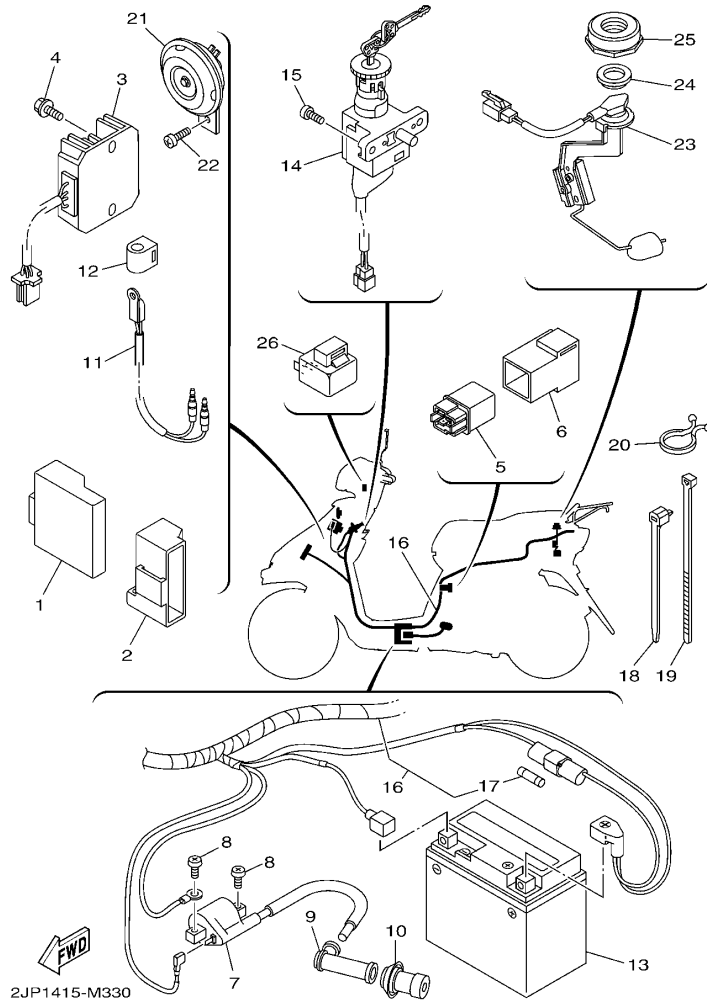

2JP1415-M330

参照 号码	零件号码 PART NO.	零件名称 DESCRIPTION	2.P1				备注 REMARKS
1	5WY-H5540-30	CDI 总成 C.D.I. UNIT ASSY	1				
2	4S0-H5546-00	箍带 BAND	1				
3	5WB-H1960-10	整流调节器 RECTIFIER & REGULATOR ASSY	1				
4	95802-06008	凸缘螺栓 BOLT, FLANGE	1				
5	5WB-H1940-10	启动继电器组合 STARTER RELAY ASSY	1				
6	5WB-H1952-00	继电器支架 HOLDER, RELAY	1				
7	5WB-H2310-01	点火线圈组合 IGNITION COIL ASSY	1				
8	98502-06018	十字螺钉 SCREW, PAN HEAD	2				
9	5WB-H2370-10	火花塞帽组合 PLUG CAP ASSY	1				
10	5WB-H2372-00	塞帽密封 SEAL, PLUG CAP	1				
11	1CC-H5700-00	温度传感器 THERMISTOR ASSY	1				
12	4S0-H3836-00	卡箍 BAND	1				
13	5WY-H2100-10	蓄电池组合 (YTX5L-BS) BATTERY ASSY (YTX5L-BS)	1				
14	5WB-H2501-10	主开关方向锁组合 MAIN SWITCH STEERING LOCK	1				
15	9760L-06210	带垫十字螺钉 SCREW, PAN HEAD	2				
16	2JP-H2590-00	电缆总成 WIRE HARNESS ASSY	1				
17	5WB-H2151-00	. 保险丝 (15A) . FUSE (15A)	2				
18	90464-12812	线夹 CLAMP	6				
19	90464-20809	线夹 CLAMP	1				
20	90464-23811	线夹 CLAMP	1				
21	5WB-H3371-01	电喇叭 HORN	1				
22	90153-06806	六角头螺钉 SCREW, HEXAGON	1				
23	5WB-H5752-10	燃油表传感装置组合 SENDER UNIT ASSY, FUEL METER	1				
24	5WB-H5753-01	传感器垫圈 GASKET, SENDER UNIT	1				
25	5WB-F4261-00	油量计壳 HOUSING, FUEL METER	1				
26	5VL-H3350-21	闪烁继电器组合 FLASHER RELAY ASSY	1				

零件号码索引
NUMERICAL INDEX

零件号码 PART NO.	参照 号码	零件号码 PART NO.	参照 号码	零件号码 PART NO.	参照 号码	零件号码 PART NO.	参照 号码	零件号码 PART NO.	参照 号码	零件号码 PART NO.	参照 号码
5WB-E1111-20	1 - 1	5WB-E3575-01	6 - 4	5WB-E5121-00	9 - 2	5WB-F1161-01	24 - 10	5WB-F3192-01	17 - 16	5WY-F5155-01	20 - 20
5WB-E1111F-00	3 - 22	5WB-E3585-21	6 - 1	5WB-E5138-00	9 - 3	5WB-F118W-00	13 - 13	4KL-F5159-00	17 - 31	4KL-F5159-00	20 - 22
5WB-E1145-01	3 - 14	5WB-E3595-00	6 - 22	5WB-E5191-00	9 - 24	2JP-F1232-00	13 - 14	5WB-F3317-01	17 - 36	5WY-F5180-00-33	20 - 1
5WB-E1155-00	1 - 11	5WB-E4105-10	7 - 17	5WB-E5351-00	5 - 9	5WB-F1398-01	19 - 15	5WB-F3340-01	17 - 32	5WB-F5181-10	20 - 28
5WB-E1160-02	1 - 7	5WB-E4115-00	7 - 10	5WB-E5363-00	9 - 14	5WB-F1410-00	13 - 5	5WB-F3346-01	17 - 33	5WB-F5315-00	20 - 25
5WB-E1165-01	1 - 9	5WB-E4196-20	7 - 21	5WB-E5363-10	9 - 35	5WB-F1420-00	13 - 2	4S9-F3356-01	17 - 13	5WB-F5326-01	21 - 5
5WB-E1181-00	1 - 19	5WB-E4283-11	7 - 4	5WB-E5371-01	9 - 5	5WB-F1459-01	13 - 8		17 - 28	5WB-F5336-00	21 - 1
5WB-E1185-01	1 - 8	5WB-E4286-10	7 - 11	5WB-E5373-00	9 - 6	5WB-F1481-01	13 - 3	5WB-F3411-00	17 - 38	5WY-F5336-00	20 - 2
5WB-E1186-00	1 - 14	5WB-E4301-50	7 - 1	5WB-E5407-00	9 - 39	2JP-F1519-00	14 - 9	5WB-F3412-00	17 - 39	5WB-F533A-01	21 - 14
5WB-E1310-01	1 - 23	5WB-E4340-00	7 - 13	5WB-E5411-00	9 - 20	2JP-F1552-00	14 - 2	5WB-F3413-00	17 - 35	5WB-F5351-01	21 - 11
5WB-E1351-10	1 - 24	5WB-E4342-16	7 - 6	5WB-E5417-00	9 - 27	5WB-F1553-00	14 - 4	5WB-F3416-01	17 - 44	4S9-F5351-10	20 - 18
5WB-E1400-01	2 - 1	5WB-E4343-52	7 - 7	5WB-E5421-00	9 - 16	5WB-F1557-00	24 - 8	5WB-F3418-01	17 - 43	5WB-F5355-01	21 - 13
5WB-E1603-00	2 - 9	5WB-E4346-00	7 - 20	5WB-E5451-00	9 - 21	5WB-F1611-00	14 - 12	5WB-F341E-00	17 - 40	5WB-F5390-10-33	21 - 4
5WB-E1631-00	2 - 6	5WB-E4370-11	7 - 19	5WB-E5455-10	9 - 25	2JP-F1685-00	14 - 16	5WB-F4110-10	18 - 1	5WB-F6110-20	22 - 1
5WB-E1633-00	2 - 7	5WB-E4384-10	7 - 14	5WB-E5461-00	9 - 17	5WB-F1710-00	15 - 1	4S0-F4135-00	18 - 22	5WB-F6113-00	22 - 2
5WB-E2111-00	3 - 1	5WB-E4385-10	7 - 18	5WB-E5471-01	9 - 37	5WB-F1753-00	18 - 15	5WB-F414A-02	18 - 14	5WB-F6145-20	25 - 3
5WB-E2113-00	3 - 5	5LB-E4386-00	7 - 9	5WB-E5472-00	9 - 38	5WB-F1823-01	24 - 9	5WY-F4170-00	18 - 26	2JP-F6240-00	22 - 7
5WB-E2116-00	3 - 4	5WB-E4390-00	7 - 8	5WB-E5481-01	9 - 42	5WB-F1875-00	15 - 10	18C-F4180-01	18 - 21	2JP-F6241-00	22 - 6
5WB-E2117-00	3 - 7	5WB-E439G-00	7 - 22	5WG-E5521-00	10 - 3	5WB-F2210-30	16 - 1	5WB-F4181-00	18 - 17	4P7-F6270-01	22 - 8
5WB-E2118-00	3 - 6	5WB-E4410-13	6 - 5	5WB-E5524-00	10 - 7	5WB-F2216-00	9 - 4	5WB-F4182-00	18 - 18	5WY-F6280-40	25 - 7
5WB-E2119-00	3 - 3	5WB-E4411-03	6 - 6	5MH-E5532-00	10 - 5	5WB-F3100-20	17 - 1	5WB-F4183-00	18 - 19	5WY-F6290-40	25 - 6
5WB-E2121-00	3 - 2	5WB-E4412-00	6 - 9	5WB-E5570-01	10 - 10	5WB-F3102-20	17 - 2	5WB-F4184-00	18 - 20	5WB-F6301-00	22 - 10
5WB-E2151-00	3 - 8	5WB-E4422-02	6 - 11	5WB-E5601-11	10 - 12	5WB-F3103-20	17 - 17	5WB-F4261-00	33 - 25	5WB-F6314-00	22 - 17
5WB-E2156-00	3 - 11	5WB-E4437-00	6 - 7	5WB-E5620-02	10 - 17	5WB-F3110-00	17 - 6	5WB-F4311-01	18 - 5	5WB-F6341-00	22 - 13
5WB-E2157-01	3 - 25	5WB-E443E-01	6 - 16	5WB-E5630-00	10 - 19		17 - 21	5WB-F4312-01	18 - 10	5WB-F6351-01	22 - 16
5WB-E2159-00	3 - 9	5WB-E4445-10	8 - 4	5WB-E5650-00	10 - 1	5WB-F3126-20	17 - 3	5WB-F4313-01	18 - 13	5WB-F637G-01	22 - 18
5WB-E2170-00	3 - 12	5WB-E4451-01	6 - 8	5WB-E5657-00	11 - 14	5WB-F3136-20	17 - 18	5WY-F4314-00	18 - 23	5WB-F7111-00	23 - 1
5WB-E2176-10	3 - 13	5WB-E4452-00	6 - 18	5WB-E5659-00	10 - 21	5WB-F3141-00	17 - 10	2JP-F4315-00	18 - 24	5WB-F7113-01	23 - 4
5WB-E2210-00	3 - 19	5WB-E4453-00	6 - 12	5WB-E5673-00	10 - 20		17 - 25	5WY-F4316-00	18 - 29	5WB-F7114-00	23 - 2
5WB-E2213-10	3 - 20	5WB-E4457-00	6 - 19	5WB-E6111-00	11 - 1	5WB-F3145-00	17 - 4	5WB-F4500-02	18 - 8	5WB-F7116-00	23 - 6
5WB-E2231-00	3 - 17	5WB-E4476-00	6 - 10	5WB-E6611-11	11 - 5		17 - 19	5WB-F4560-00	18 - 4	2JP-F7311-00	23 - 14
5WB-E2241-00	3 - 18	5WB-E4504-00	7 - 15	5WB-E6620-20	11 - 18	5WB-F3147-00	17 - 14	5WB-F4610-10	18 - 2	5WB-F7316-01	23 - 17
5WB-E2611-01	4 - 13	2JP-E4610-00	8 - 1	5WB-E6626-20	11 - 19		17 - 29	5WY-F4633-00	18 - 3	5WB-F7475-00	23 - 11
5WB-E2651-00	4 - 1	5WB-E4613-10	8 - 8	5WB-E7211-00	12 - 6	5WB-F3149-00	17 - 34	5WB-F4726-01	19 - 3	5WB-F7481-02	23 - 7
5WB-E2652-00	4 - 5	5WB-E4651-01	1 - 2	5WB-E7410-00	12 - 1	5WB-F3152-00	17 - 9	5WB-F4727-01	19 - 5	5WB-F8100-01	13 - 17
5WB-E2658-00	4 - 8	5WB-E4718-20	8 - 2	5WB-E7421-00	12 - 5		17 - 24	2JP-F4730-00	19 - 1	5WB-F8257-00	24 - 4
5WB-E2659-00	4 - 9	4KL-E4737-00	8 - 7	5WB-E7602-20	11 - 17	5WB-F3156-00	17 - 5	5WB-F473R-00	19 - 6	2JP-F8300-00	24 - 1
5WB-E2668-00	4 - 10	5WB-E4803-11	8 - 17	5WB-E7611-20	11 - 13		17 - 20	5WB-F4742-00	19 - 18	2JP-F8349-00	24 - 2
5WB-E3300-01	5 - 1	4P7-E4806-01	8 - 22	5WB-E7620-10	11 - 7	5WB-F3157-00	17 - 8	5WB-F475M-00	19 - 2	5WB-F8354-00	14 - 5
5WB-E3324-00	2 - 4	5WB-E4815-00	8 - 13	5WB-E7623-10	11 - 9		17 - 23	5WB-F4780-01	19 - 8	5WB-F8385-00	24 - 6
5WB-E3325-00	5 - 2	5WB-E4872-20	8 - 12	5WB-E7632-31	11 - 8	5WB-F3158-00	17 - 12	5WB-F478E-01	19 - 10	5WY-H1410-11	26 - 2
5WB-E3411-00	5 - 10	5WB-E4883-11	8 - 15	5WB-E7641-00	11 - 12		17 - 27	2JP-F4810-00	19 - 12	5WY-H1450-01	26 - 1
5WB-E3416-00	9 - 11	5WB-E4884-20	8 - 19	5WB-E7653-10	11 - 10	5WB-F3170-00	17 - 7	5WY-F5121-00-33	20 - 8	5WB-H1800-13	27 - 1
5WB-E3451-00	2 - 3	5WB-E4885-20	8 - 25	5WB-E7660-10	11 - 20		17 - 22	5WY-F5135-00	20 - 9	5WB-H1801-00	27 - 3
5WB-E3475-00	5 - 7	5WB-E490A-10	7 - 16	5WB-E7664-10	11 - 24	5WB-F3181-01	17 - 11	4KL-F5136-10	20 - 12	5WB-H183G-00	27 - 2
5WB-E3542-20	8 - 20	5WB-E490J-30	7 - 2	5WB-E7670-10	11 - 21		17 - 26	4KL-F5137-21	20 - 30	5WY-H1894-00	31 - 7
5WB-E3556-10	6 - 23	5WB-E490K-10	7 - 3	5WB-E7684-10	11 - 26	5WB-F3191-00	17 - 15	5WY-F5138-00	20 - 10	5WB-H1940-10	33 - 5
5WB-E3569-00	4 - 11	5WB-E5111-00	9 - 1	2JP-F1110-00	13 - 1		17 - 30	4KL-F513A-01	20 - 19	5WB-H1952-00	33 - 6

零件号码索引
NUMERICAL INDEX

零件号码 PART NO.	参照 号码	零件号码 PART NO.	参照 号码	零件号码 PART NO.	参照 号码	零件号码 PART NO.	参照 号码	零件号码 PART NO.	参照 号码	零件号码 PART NO.	参照 号码
5WB-H1960-10	33 - 3	5WB-WE543-00	9 - 41	90179-25810	17 - 41	90464-08800	4 - 12	93106-17806	20 - 26	95602-05100	32 - 7
5WY-H2100-10	33 - 13	1CC-X2534-00	20 - 15	90183-05818	14 - 3	90464-12812	33 - 18	93106-44800	20 - 14		32 - 12
5WB-H2129-00	23 - 18	2JP-XF151-00-P0	14 - 1		14 - 18	90464-20809	33 - 19	93109-33802	11 - 22	95602-10200	13 - 4
5WB-H2151-00	33 - 17	2JP-XF151-00-P1	14 - 1		15 - 3	90464-23811	33 - 20	93210-07808	9 - 32		13 - 7
5WB-H2310-01	33 - 7	2JP-XF151-00-P2	14 - 1		23 - 12	90465-12803	4 - 6	93210-07890	21 - 7		22 - 4
5WB-H2370-10	33 - 9	2JP-XF151-00-UG	14 - 1		25 - 2	90467-08003	18 - 30	93210-09859	21 - 12	95602-12200	20 - 27
5WB-H2372-00	33 - 10	2JP-XF173-00-P0	15 - 4	90185-08818	23 - 16	90467-08070	8 - 21	93210-14104	20 - 31	95702-06500	6 - 3
5WB-H2501-10	33 - 14	2JP-XF173-00-P1	15 - 4	90185-14807	21 - 17	90467-09006	18 - 11	93210-14811	9 - 15		8 - 14
2JP-H252H-00	23 - 8	2JP-XF173-00-P2	15 - 4	90201-06814	8 - 5		18 - 25	93210-15639	13 - 9		8 - 24
2JP-H2590-00	33 - 16	2JP-XF173-00-UG	15 - 4	90201-06850	14 - 8	90467-10803	18 - 7	93210-15802	3 - 24		13 - 15
2JP-H3310-00	28 - 1	2JP-XF174-00-P0	15 - 7	90201-06879	6 - 14		18 - 12	93210-25809	6 - 2		18 - 27
2JP-H3311-00	28 - 2	2JP-XF174-00-P1	15 - 7		23 - 10	90467-12802	18 - 6	93210-26804	9 - 36		19 - 4
	28 - 5	2JP-XF174-00-P2	15 - 7	90201-07076	20 - 11	90467-12814	9 - 7	93210-35801	5 - 12		24 - 13
1CC-H3311-10	31 - 5	2JP-XF174-00-UG	15 - 7	90201-07811	5 - 5	90467-13804	1 - 26	93210-36800	11 - 23	95702-10500	16 - 4
2JP-H3320-00	28 - 4	5WB-XF253-01	21 - 8	90201-08827	1 - 16	90467-13817	6 - 17	93210-44807	1 - 15		21 - 6
5VL-H3350-21	33 - 26	2JP-XF614-00-P0	25 - 1	90201-10825	10 - 4	90467-16805	8 - 16	93210-62802	1 - 12	95802-06008	33 - 4
5WB-H3371-01	33 - 21	2JP-XF614-00-P1	25 - 1	90201-12172	9 - 44	90467-16808	8 - 26	93211-02801	9 - 31	95802-06010	17 - 37
5WB-H3510-30	29 - 1	2JP-XF614-00-P2	25 - 1	90201-14810	21 - 16	90480-12053	14 - 15	93306-003YK	10 - 8		19 - 9
5WB-H3517-00	29 - 2	2JP-XF614-00-UG	25 - 1	90201-15816	12 - 4	90480-30800	4 - 4	93306-200Y5	11 - 4	95802-06012	8 - 18
5WB-H3517-10	29 - 3	90101-06046	20 - 23	90201-15838	10 - 15	90501-16806	5 - 11		12 - 3		14 - 6
5WB-H3550-10	29 - 5	90101-06818	21 - 15	90201-17485	13 - 10	90501-43804	11 - 25	93306-201X4	20 - 5	95802-08016	13 - 16
4S0-H3836-00	33 - 12	90101-10809	16 - 3	90201-203E7	21 - 18	90506-12001	20 - 16	93306-203XE	11 - 2	95802-10030	13 - 12
5WB-H3912-10	32 - 10	90105-08861	16 - 2	90202-15804	23 - 3		21 - 9		12 - 11	95812-08016	3 - 15
5WY-H3922-10	32 - 3	90105-10036	22 - 3	90202-26142	17 - 42	90506-15001	20 - 17	93306-204YJ	12 - 9		9 - 12
5WB-H3945-00	32 - 6	90105-10862	13 - 6	90202-26801	27 - 4		21 - 10	93306-205XL	2 - 2	95812-08030	8 - 11
	32 - 11	90109-06887	14 - 17	90208-12804	11 - 15	90508-26801	20 - 21	93306-301XJ	20 - 4	95812-08050	8 - 10
	32 - 8		19 - 7	90208-21802	12 - 7	90508-32804	10 - 13	93311-315Y8	12 - 2	95822-10035	23 - 5
5WY-H3963-11	32 - 9	90109-08821	23 - 15	90249-12008	22 - 15	90560-12138	20 - 3	93315-110Y6	10 - 2	97002-06016	14 - 7
4S0-H3975-01	32 - 1	90113-06804	1 - 5		22 - 21	91312-06012	3 - 23	93410-20823	12 - 8	97002-06030	23 - 9
5WB-H3980-01	32 - 4	90116-06820	1 - 6	90269-06809	15 - 5	91312-06014	18 - 9	93450-15825	2 - 8	97502-05510	24 - 11
	30 - 5	90116-08811	1 - 27		15 - 8	91312-06016	3 - 21	93450-35826	10 - 9	97522-06512	1 - 10
5WY-H4146-00	30 - 4	90149-05807	30 - 6	90280-03801	2 - 5	91312-06020	27 - 5	93602-12801	5 - 4	97601-04014	7 - 12
5WY-H4147-00	30 - 4	90153-06806	1 - 3	90340-12814	9 - 43	91312-06025	10 - 18	93603-12802	5 - 3	97602-06212	19 - 16
5WY-H4310-10	30 - 1			90380-15806	10 - 14	91312-06090	1 - 22	93900-00835	20 - 7	97602-06225	6 - 15
5WY-H4312-10	30 - 3		33 - 22	90159-05812	25 - 4	91808-12804	9 - 33		21 - 3		6 - 21
4KL-H4314-00	30 - 2	90159-05812	25 - 4	90387-063F7	14 - 14	91810-14805	1 - 20	94109-10813	20 - 6		26 - 6
2JP-H4340-00	28 - 3	90159-06842	24 - 5	90387-068F6	8 - 3		1 - 21		21 - 2	9760L-06210	33 - 15
2JP-H4350-00	28 - 6	90159-06858	4 - 14	90387-068J2	8 - 23		9 - 8	94568-A2084	3 - 16	97702-50012	14 - 11
5WY-H4540-30	31 - 2	90159-06867	14 - 13		18 - 28		9 - 18	94700-00869	1 - 18		15 - 2
5WY-H4700-30	31 - 1	90170-05801	3 - 10	90387-068K5	4 - 2		9 - 22	95022-06020	1 - 13		15 - 6
4KL-H4714-20	31 - 4	90170-12181	26 - 5	90387-12853	26 - 4		18 - 16		9 - 34		15 - 9
5WY-H4743-30	31 - 3	90170-28802	11 - 27	90387-128M1	20 - 29	91A11-07048	10 - 11	95022-06030	9 - 19		23 - 19
1CC-H5130-00	14 - 19	90176-06802	24 - 14	90387-16806	10 - 11	92012-05010	22 - 12	95022-06035	9 - 23		25 - 5
2JP-H5141-00	24 - 12	90176-08812	1 - 17	90387-16816	11 - 11	93102-17808	11 - 3	95022-06070	9 - 9		31 - 8
5WY-H5540-30	33 - 1	90179-06824	8 - 9	90430-06800	1 - 4	93102-19008	9 - 30	95022-06075	19 - 13	97702-50016	14 - 10
4S0-H5546-00	33 - 2	90179-06841	19 - 17		9 - 28	93102-19805	9 - 29		19 - 14		22 - 5
1CC-H5700-00	33 - 11	90179-06843	22 - 14	90430-08816	9 - 13	93102-22811	9 - 10	95022-08045	19 - 14		23 - 13
5WB-H5752-10	33 - 23		22 - 20	90445-14805	1 - 25	93102-26803	12 - 10	95302-06600	20 - 24		22 - 5
5WB-H5753-01	33 - 24	90179-10817	11 - 6	90450-45803	6 - 20	93104-07803	20 - 13	95302-12700	11 - 16		24 - 3

零件号码索引
NUMERICAL INDEX

零件号码 PART NO.	参照 号码	零件号码 PART NO.	参照 号码	零件号码 PART NO.	参照 号码	零件号码 PART NO.	参照 号码	零件号码 PART NO.	参照 号码	零件号码 PART NO.	参照 号码
97702-50016	24 - 7										
	28 - 7										
	29 - 4										
97702-60530	4 - 7										
97707-40612	31 - 6										
98501-04008	7 - 5										
98502-03005	32 - 2										
	32 - 5										
98502-05010	19 - 11										
	22 - 11										
98502-05020	22 - 9										
98502-06012	10 - 6										
	22 - 19										
98502-06014	26 - 3										
98502-06018	33 - 8										
98502-06020	4 - 3										
98502-06025	6 - 13										
98702-06020	5 - 8										
98902-06010	9 - 26										
98902-06020	9 - 40										
98980-06020	8 - 6										
99001-05600	5 - 6										
99009-15400	10 - 16										
99009-17400	13 - 11										

雅马哈纯正用品大集结



① 纯色头盔(全盔)

- BL
- RD
- BK



④ 纯色头盔(半盔)

- BL
- RD
- BK



② 锋利头盔(全盔)

- BL
- RD
- BK
- WH



⑤ 锋利头盔(半盔)

- BL
- RD
- BK
- WH



③ 鹰眼头盔(全盔)

- BL
- RD
- BK



⑥ 飞行盔(半盔)

- BL
- BR
- BK
- WH

编号①: Q01-00001-尺寸代码-颜色代码

编号②: Q01-00003-尺寸代码-颜色代码

编号③: Q01-NS001-尺寸代码-颜色代码

编号④: Q01-00002-尺寸代码-颜色代码

编号⑤: Q01-00004-尺寸代码-颜色代码

编号⑥: Q01-00006-尺寸代码-颜色代码

尺寸	M	L	XL	XXL
尺寸代码	0M	0L	0X	2X



YAMAHA尾箱

编号: Q41-20000-33-BK

YAMAHA尾箱靠背

编号: Q41-20000-33-CC

雅马哈纯正机油大集结



纯正机油

品质保证! 动力之源!

请经销YAMALUBE纯正 机油!



90793-AC421-T1
90793-AC421-G1
SAE 10W-40 (1L)
高等级/通用



90793-AC432-00
SAE 10W-30 (1L)
通用机油



90793-AC423-T2
90793-AC423-G2
SAE 20W-40 (1L)
通用机油



90793-AC427-T1
90793-AC427-G1
SAE 10W-40 (0.8L)
弯梁车专用



90793-AC426-T1
SAE 5W-30 (1L)
冬季专用/通用



90793-AC434-00
SAE 10W-30 (0.8L)
弯梁车专用



90793-AC423-P1
SAE 20W-40 (1L)
通用机油



90793-AC404
GEAR (0.13L)
齿轮油
踏板车专用

友情提示：磨合期后，建议每1500KM更换一次机油(可根据实际使用状况减少里程数)。并清洗机油滤网。