

翻印必究



上海雅马哈建设摩托车销售有限公司

<http://www.yamaha-motor.com.cn/>

第一版 2014年1月



SHANGHAI YAMAHA JIANSHE MOTOR MARKETING CO., LTD.

零件目录

JYM125-8(2PJ4)

2PJ-F8198-1M-MA

1M2PJ-415MA



JYM125-8(2PJ4)



2PJ4 (鼓刹, 压铸, 脚启动版, 前减震套)

代号	颜色
0903	梦幻黑



代号	颜色
0580	宝石红



代号	颜色
0564	宝石蓝



前言

本零件目录图册记载着封面页所示型号摩托车所使用的零件。当您订购更换零件时，请参阅本零件目录并正确指示零件号码和零件名称。

1. 零件目录发行后有变更或附加零件时，将会以雅马哈零件信息通知大家。建议您应按照雅马哈零件信息修改本零件目录。

2. 省略记号

本文中所记载的省略记号的意思如下。

“UR” 需要指定的零件号码。

3. 组件中部件的数量

- 组件的销售零件，如下所示，在零件名称的前面加上 (.) 的记号来表示。
- 每个部件右侧的数字表示各组件单体内该部件的数量。

参照号码	部品番号	零件名称	数量	备注
1	2PJ-F4730-00	坐垫 DBL. SEAT ASSY.	1	
2	2PJ-F4741-00	缓冲垫 .PAD, SEAT	6	

4. 适用的图形颜色表示在“备注”中，如下所示。

参照号码	部品番号	零件名称	数量	备注
1	2PJ-F4110-00-PO	油箱体 FUEL TANK COMP.	1	UR 红色车用 UR FPR RED
2	2PJ-F4110-00-P1	油箱体 FUEL TANK COMP.	1	UR 黑色车用 UR FOR BLACK

5. 请注意插图只用于找寻零件号码时参照，并不适用于组装。组装时，请使用适用的维修手册。

6. 在参照号码前的星号 (*) 表示其为在第一版后更改的项目。

7. 适用的系列号码

车架系列号码



发动机系列号码



8. 适用的初始系列号码

车架系列号码

系列号码	数据栏名称	型号记号

发动机系列号码

系列号码	数据栏名称	型号记号

9. 颜色信息

型号代码	颜色类型代码	颜色记号	颜色名称 (英文)	颜色名称
	A	010D	Red	红色
	B	010E	Black	黑色
	C	010H	Blue	蓝色

目录

发动机

图 1 气缸头、气缸体.....	1
图 2 进、排气门.....	2
图 3 配气机构.....	3
图 4 曲轴、活塞.....	4
图 5 曲轴箱.....	5
图 6 曲轴箱盖.....	6
图 7 离合器.....	7
图 8 主副轴齿轮.....	9
图 9 换挡凸轮 拨叉.....	11
图 10 换挡轴.....	12
图 11 机油泵.....	13
图 12 空气滤清器.....	14
图 13 化油器.....	15
图 14 消声器.....	17
图 15 电启动系统.....	18
图 16 脚启动系统.....	19

底盘

图 17 车架.....	20
图 18 二次进气.....	22
图 19 挡泥板.....	24
图 20 挡泥板.....	26
图 21 方向把、拉索.....	27
图 22 手把开关.....	28
图 23 前叉.....	29
图 24 前减震器.....	31
图 25 后轮悬挂.....	32
图 26 主支架、搁脚 T.....	33
图 27 油箱.....	35
图 28 座垫.....	37
图 29 前压铸轮.....	38
图 30 后压铸轮.....	40
图 31 仪表.....	42
图 32 转向灯.....	44
图 33 前照灯.....	45
图 34 尾灯.....	46
图 35-1 电器 1.....	47
图 36-2 电器 2.....	48

索引

零件号码索引.....	49
-------------	----

CONTENTS

ENGINE

CYLINDER HEAD、CYLINDER BODY.....	1
INLET, EXHAUST VALVE	2
GAS DISTRIBUTION MECHANISM.....	3
THE CRANKSHAFT AND PISTON	4
THE CRANKSHAFT BOX.....	5
CRANKSHAFT COVER.....	6
CLUTCH.....	7
THE MAIN SHAFT GEAR	9
SHIFTING CAM SHIFTING FORK.....	11
THE SHIFT SHAFT	12
THE OIL PUMP	13
AIR FILTER.....	14
CARBURETOR.....	15
MUFFLER.....	17
ELECTRIC STARTING SYSTEM	18
KICK STARTING SYSTEM.....	19

CHASSIS

FRAME.....	20
GAS CIRCULATE SYSTEM	22
FENDER.....	24
FENDER.....	26
STEERING HANDLE & CABLE	27
HANDLE SWITCH & LEVER.....	28
FRONT FORK	29
FRONT SHOCK ABSORBER	31
REAR SUSPENSION.....	32
STAND & FOOTREST	33
FUEL TANK	35
SEAT.....	37
FRONT WHEEL FOR CAST WHEEL.....	38
REAR WHEEL FOR CAST WHEEL	40
METER.....	42
FLASHER LIGHT	44
HEADLIGHT	45
TAILLIGHT	46
ELECTRICAL 1	47
ELECTRICAL 2	48

INDEX

PARTS NO INDEX CHART	49
----------------------------	----



图1 气缸头、气缸体 CYLINDER HEAD、CYLINDER BODY

参照 号码	部品番号	中文名称 英文名称	状态	备注
			2PJ4	
1	5VL-E1111-11	气缸头 HEAD, CYLINDER1	1	
2	2UJ-11133-10	. 进气门导管 . GUIDE, VALVE1	1	
3	22F-11134-10	. 排气门导管 . GUIDE, VALVE2	1	
4	93440-10109	. 卡环 . CIRCLIP	2	
5	90153-06803	. 六角头螺栓 . SCREW, CROSSRECESSEDHEX.	1	
6	90430-06817	. 垫圈 . GASKET	1	
7	5VL-E1185-10	气缸头侧盖 3 COVER, CYL.HEADSIDE3	1	
8	93210-79802	O 型圈 O-RING	1	
9	95022-06020	六角法兰面螺栓 (小头) BOLT, FLG.(SMALLHEAD)	2	
10	5VL-E1186-00	气缸盖侧盖 1 COVER, CYLINDERHEADSIDE1	2	
11	93210-44812	O 型圈 O-RING	2	
12	90105-08724	六角法兰面螺栓 BOLT, FLG.	4	
13	90201-088C3	平垫圈 WASHER, PLAIN	4	
14	94700-00869	火花塞 PLUG, SPARK	1	
15	1BK-E1181-00	气缸头垫片 GASKET, CYLINDERHEAD1	1	
16	99530-10114	定位销 PIN, DOWELA	2	
17	91312-06090	六角螺栓 BOLT, HEX.SOCKETHEAD	2	
18	1BK-E1310-00	气缸体总成 CYL.ASSY., 1	1	
19	5VL-E1351-10	汽缸衬垫 GASKET, CYLINDER1	1	

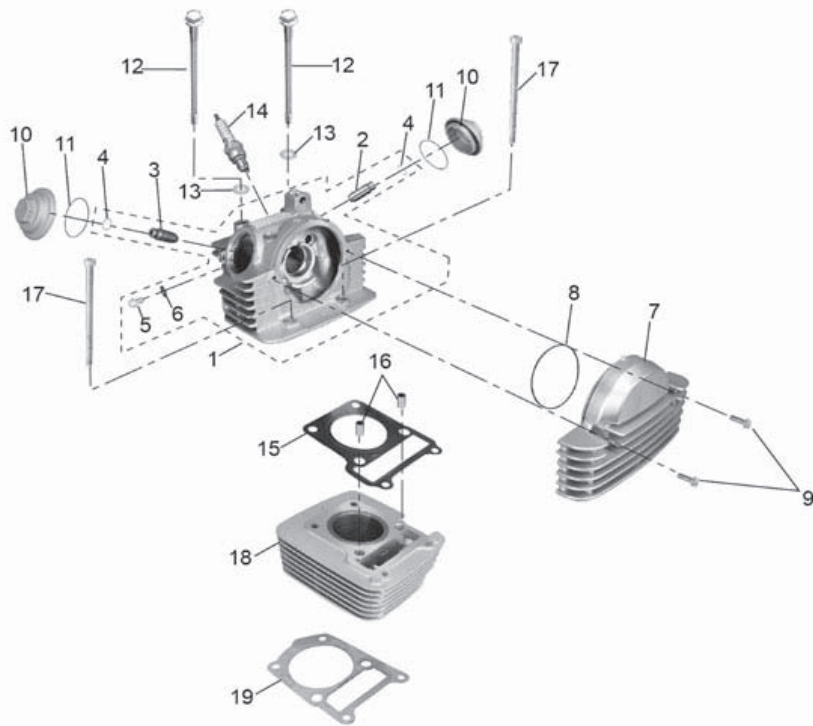

图 2 进、排气门

INLET, SXHAUST VALVE

参照 号码	部品番号	中文名称 英文名称	状态	备注
			2PJ4	
1	1BK-E2111-00	气门 1 VALVE, 1	1	
2	1BK-E2121-00	气门 2 VALVE, 2	1	
3	1BK-E2119-00	气门杆油封 SEAL, VALVESTEMOIL	2	
4	5VL-E2116-01	气门弹簧座 SEAT, VALVESPRING	2	
5	1SF-E2113-00	气门弹簧 SPRG., 1	2	
6	5VL-E2118-00	气门锁夹 LOCK, VALVESPRINGRETAINER	4	
7	5VL-E2117-01	气门弹簧座 RET., VALVESPRING	2	
8	5VL-E2151-00	气门摇臂 1 ARM, VALVEROCKER1	2	
9	5VL-Y1215-00	调节螺钉 Adjustment screw	2	
10	5VL-E2156-00	摇臂轴 2 SHAFT, ROCKER2	2	

图 3 配气机构

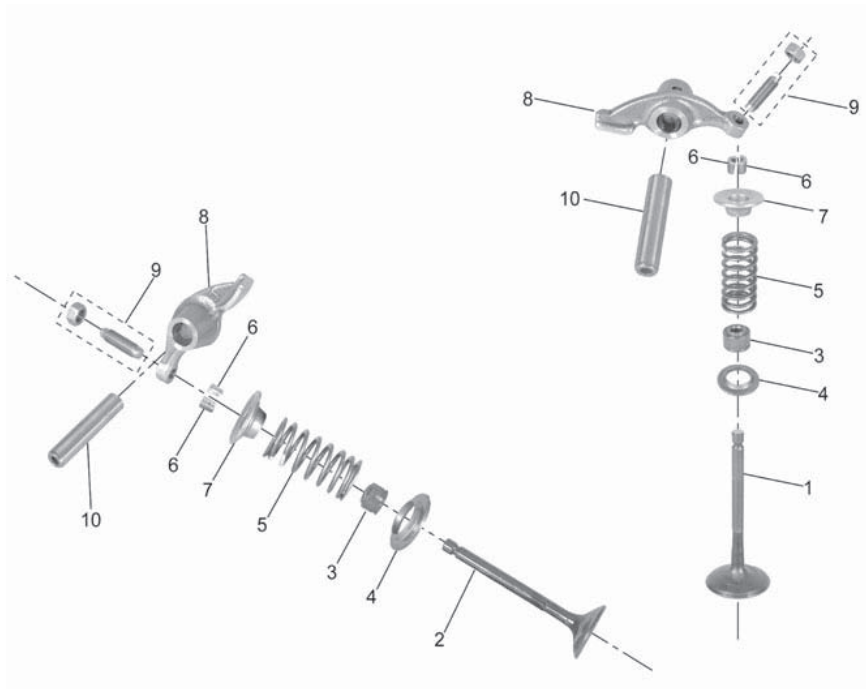
GAS DISTRIBUTION MECHANISM

参照 号码	部品番号	中文名称 英文名称	状态	备注
			2PJ4	
1	1BK-E2171-00	凸轮轴 1 SHAFT, CAM1	1	
2	93306-002YM	轴承 BRG.	1	
3	93306-003YS	轴承 BRG.	1	
4	5VL-E111F-00	压板 PLATE	1	
5	91312-06012	内六角柱头螺栓 BOLT, HEX.SOCKETHHEAD	1	
6	5VL-E2176-00	正时链轮 SPROCKET	1	
7	90201-08326	平垫圈 WASHER, PLAIN	1	
8	90101-08820	六角头螺栓 BOLT, HEX.	1	
9	94568-C1088	链条 CHAIN	1	
10	5VL-E2231-00	链条导向板 GUIDE, STOPPER1	1	
11	5VL-E2241-00	链条导向板 2 GUIDE, STOPPER2	1	
12	5VL-E5598-00	轴套 COLLAR	1	
13	95802-06020	法兰螺栓 BOLT, FLG.	1	
14	5VL-E2210-01	链条张紧器组合 TENSIONERASSY.	1	
15	5VL-E2213-10	张紧器衬垫 1 GASKET, TENSIONERCASE1	1	
16	95022-06016	六角法兰面螺栓 (小头) BOLT, FLG.(SMALLHEAD)	2	
17	90430-06817	垫圈 GASKET	2	
18	90387-167L5	套垫圈 COLLAR	1	



图 4 曲轴、活塞

THE CRANKSHAFT AND PISTON

参照 号码	部品番号	中文名称 英文名称	状态	备注
			2PJ4	
1	5VL-W1140-20	曲轴连杆组合 Crankshaft assy	1	
2	5VL-W1141-00	. 曲柄 1 . CRANK, 1	1	
3	5VL-E1681-00	. 曲柄销 . PIN, CRANK	1	
4	93310-629Y3	. 轴承 . BRG	1	
5	5VL-E1651-00	. 连杆 1 . ROD, CONNECTING1	1	
6	5VL-E1422-00	. 曲柄 2 . CRANK, 2	1	
7	5VL-Y1153-00	. 平衡轴齿轮总成 . GEAR, BALANCE WEIGHT ASSY	1	
8	5VL-E1454-00	. 平衡轴 1 . WEIGHT 1	1	
9	93210-11809	. O 型圈 . O-RING	2	
10	93306-205YP	轴承 BRG.	1	
11	5VL-E1631-00	活塞 PISTON	1	
12	5VL-E1633-00	活塞销 PIN, PISTON	1	
13	93450-16812	弹性挡圈 CIRCLIP	1	
14	5VL-W1161-00	活塞环套件 PISTON RING SET	1	
15	93306-202XN	轴承 BRG.	2	
16	90280-03017	半圆键 KEY, WOODRUFF	1	
17	90201-122H1	平垫圈 WASHER, PLAIN	1	
18	90179-12863	螺母 NUT	1	



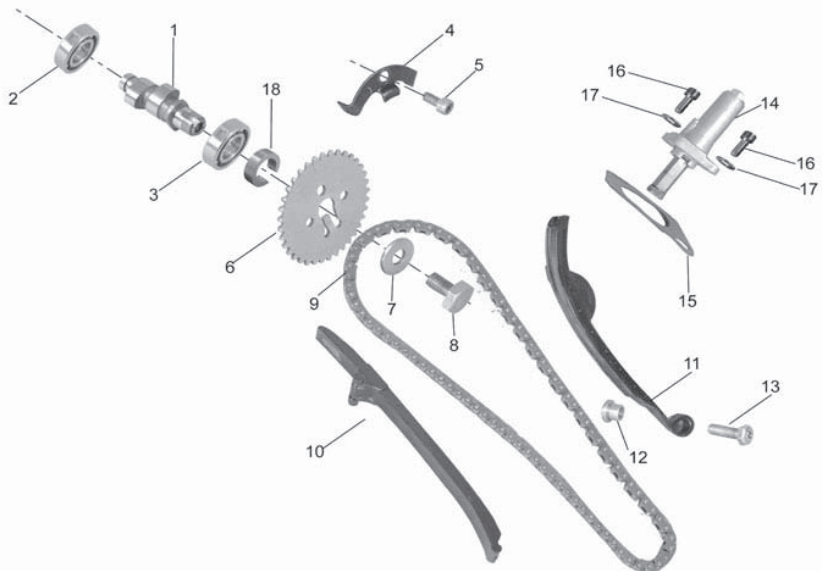
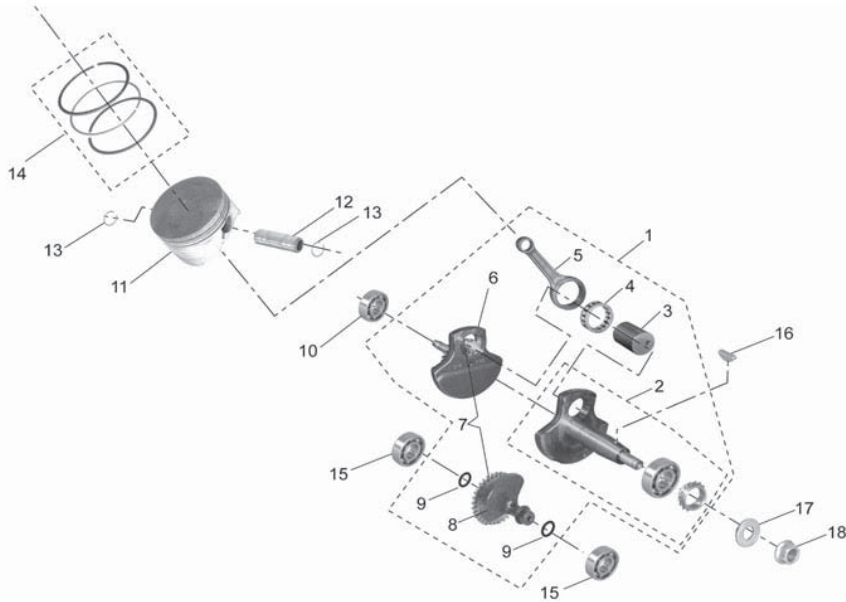

图 5 曲轴箱

THE CRANKSHAFT BOX

参照 号码	部品番号	中文名称 英文名称	状态	备注
			2PJ4	
1	1SF-W1510-00	曲轴箱组合 CRANKCASEASSY.	1	
2	99530-10114	. 定位销 . PIN, DOWELA	2	
3	4FP-E1167-00	通气管 2 PIPE, BREATHER2	1	
4	2PJ-E1166-00	废气循环管 Exhaust gas recycling tube	1	
5	2PJ-RAC07-00	卡箍 Clamp	2	
6	90462-16801	夹线架 CLAMP	1	
7	95022-06030	六角法兰面螺栓 (小头) BOLT, FLG.(SMALLHEAD)	2	
8	95022-06045	六角法兰面螺栓 (小头) BOLT, FLG.(SMALLHEAD)	7	
9	95022-06055	六角法兰面螺栓 (小头) BOLT, FLG.(SMALLHEAD)	1	
10	99530-10114	定位销 PIN, DOWELA	2	
11	5VL-E5441-01	离合器拉索支架 HOLDER, CLUTCHWIRE	1	

图 6 曲轴箱盖

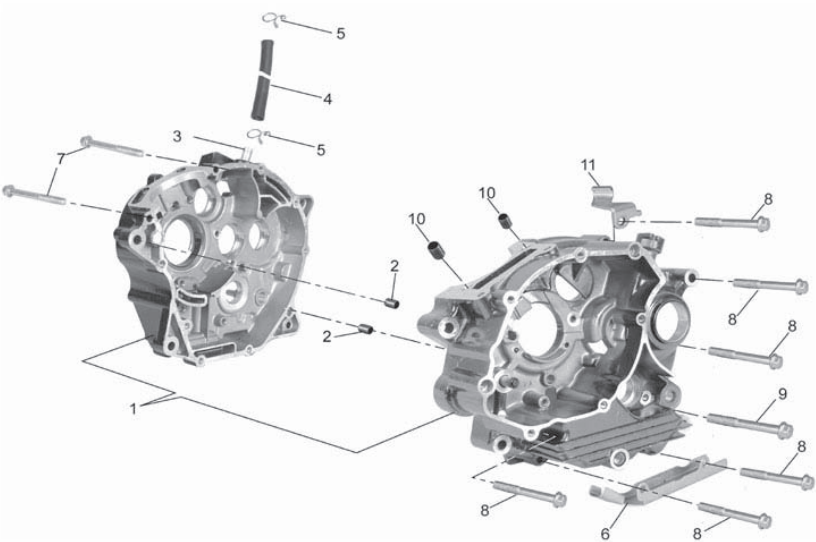
CRANKCASE COVER

参照 号码	部品番号	中文名称 英文名称	状态	备注
			2PJ4	
1	5VL-E5421-20	曲轴箱盖 2 COVER, CRANKCASE2	1	
2	95022-06035	六角法兰面螺栓 (小头) BOLT, FLG.(SMALLHEAD)	7	
3	99530-10114	定位销 PIN, DOWELA	2	
4	95022-06045	六角法兰面螺栓 (小头) BOLT, FLG.(SMALLHEAD)	2	
5	5VL-E5362-00	油塞 PLUG, OILLEVEL	1	
6	93210-19808	O 型圈 O-RING	1	
7	93101-10800	油封 SEAL, OIL	1	
8	5VL-E5461-10	曲轴箱盖垫片 2 GSKT., CRANKCASECOVER2	1	
9	2PJ-E5418-00	链轮盖组合 Sprocket cover combination	1	
10	2PJ-RA223-00	螺栓 Bolt	2	
11	90340-14810	螺塞 PLUG, STRAIGHTSCREW	1	
12	93210-14817	O 型圈 O-RING	1	
13	95022-06050	六角法兰面螺栓 (小头) BOLT, FLG.(SMALLHEAD)	6	
14	99530-10114	定位销 PIN, DOWELA	2	
15	95022-06035	六角法兰面螺栓 (小头) BOLT, FLG.(SMALLHEAD)	1	
16	5VL-E5451-10	曲轴箱左盖衬片 GSKT., CRANKCASECOVER1	1	
17	1SF-E5411-00	左曲轴箱盖 COVER, CRANKCASE1	1	
18	5VL-E5191-00	板 PLATE	1	
19	98512-06010	十字槽盘头螺钉 SCREW, PANHEAD(+)	1	



图7 离合器

CLUTCH

参照 号码	部品番号	中文名称 英文名称	状态	备注
			2PJ4	
1	1BK-E6111-00	主驱动齿轮 GEAR, PRIMARYDRIVE	1	
2	90282-05001	平键 KEY, STRAIGHT	1	
3	90201-122H1	平垫圈 WASHER, PLAIN	1	
4	90179-12813	螺母 NUT	1	
5	1BK-E6300-10	离合器 CLUTCHASSY.	1	
6	1BK-E6150-00	. 从动齿轮组合 . DRIVENGEARASSY.	1	
7	1BK-E6154-00	. 推板 1 . PLATE, THRUST1	1	
8	1BK-E6371-10	. 离合器轮毂 . BOSS, CLUTCH	1	
9	1BK-E6321-10	. 离合器片 1 . PLATE, CLUTCH1	4	
10	1BK-E6324-10	. 摩擦片 . PLATE, FRICTION1	5	
11	1BK-E6351-10	. 压板 1 . PLATE, PRESSURE1	1	
12	1BK-E6333-00	. 离合器弹簧 1 . SPRG., CLUTCH1	4	
13	1BK-E6337-00	. 弹簧螺钉 . SCREW, SPRING1	4	
14	5VL-Y1635-10	推杆组合 PLATE, PUSH	1	
15	92902-06200	垫圈 WASHER, PLAIN	1	
16	95302-06600	六角螺母 NUT, HEX.	1	
17	5VL-E6164-10	推力板 PLATE, THRUST2	1	
18	90215-12211	止动垫圈 WASHER, TONGUED	1	
19	90170-12060	六角螺母 NUT, HEX.	1	
20	93503-16824	钢球 BALL	1	

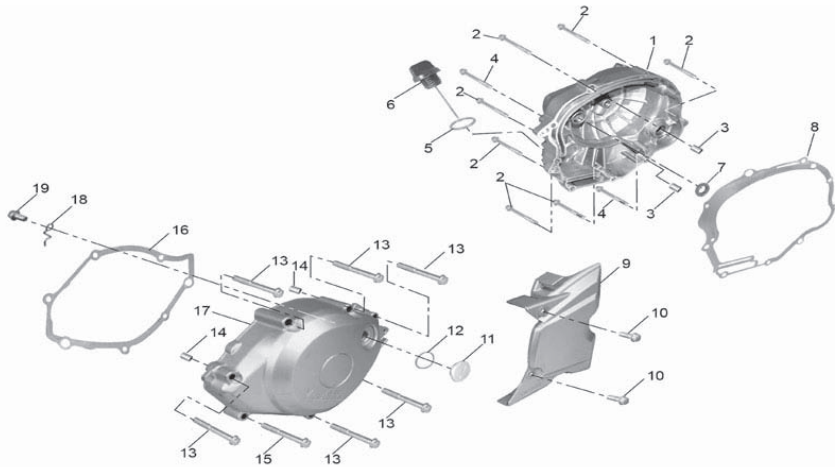

图 7 离合器

CLUTCH

参照 号码	部品番号	中文名称 英文名称	状态	备注
			2PJ4	
21	5VL-E6357-01	推杆 ROD, PUSH	1	
22	5VL-E6381-02	推杆总成 PUSHLEVERCOMP.	1	
23	90508-16800	拉簧 SPRG., TORSION	1	
24	93102-12812	油封 SEAL, OIL	1	
25	99009-20500	卡圈 (轴用) CIRCLIP(R)	1	



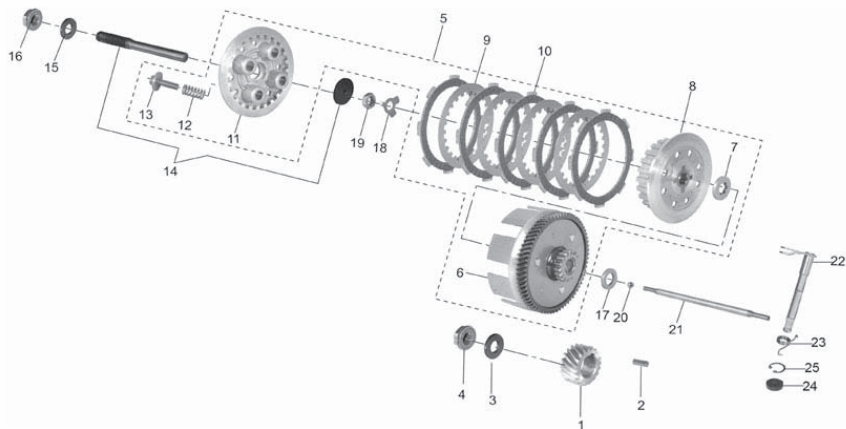
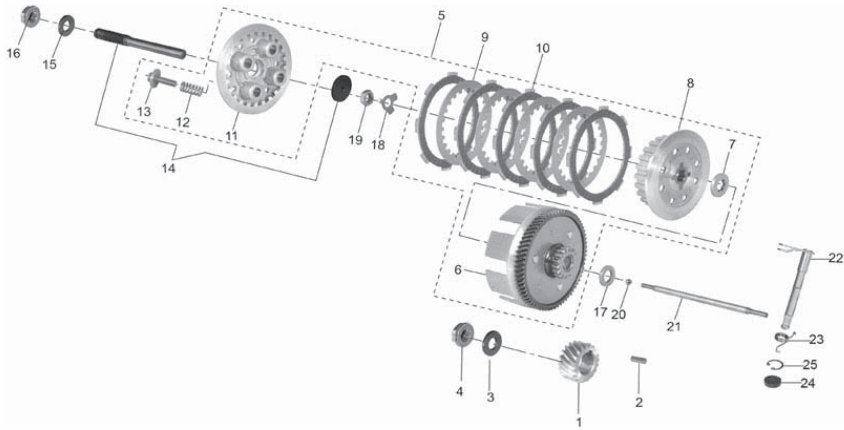

图 8 主副轴齿轮

THE MAIN SHAFT GEAR

参照 号码	部品番号	中文名称 英文名称	状态	备注
			2PJ4	
1	5VL-E7411-00	主轴 AXLE, MAIN	1	
2	5VL-E7151-00	五挡主动齿轮 GEAR, 5THPINION	1	
3	5VL-E7121-00	二挡主动齿轮 GEAR, 2NDPINION	1	
4	5VL-E7131-00	三挡主动齿轮 GEAR, 3RDPINION	1	
5	5VL-E7141-00	四挡主动齿轮 GEAR, 4THPINION	1	
6	90201-20266	平垫圈 WASHER, PLAIN	1	
7	93410-20809	卡圈 CIRCLIP	1	
8	93306-201YD	轴承 BRG.	1	
9	93306-203YT	轴承 BRG.	1	
10	5VL-E7471-00	轴承挡板 PLATE, COVER	1	
11	98512-06012	十字槽盘头螺钉 SCREW, PANHEAD(+)	2	
12	5VL-E7402-00	驱动轴组合 Combination of the drive shaft	1	
13	5VL-E7251-00	五挡从动齿轮 GEAR, 5THWHEEL	1	
14	5VL-E7221-00	二挡从动齿轮 GEAR, 2NDWHEEL	1	
15	5VL-E7231-00	三挡从动齿轮 GEAR, 3RDWHEEL	1	
16	90201-20266	平垫圈 WASHER, PLAIN	1	
17	93410-20809	卡圈 CIRCLIP	1	
18	5VL-E7241-00	四挡从动齿轮 GEAR, 4THWHEEL	1	
19	5VL-E7211-00	一档从动齿轮 GEAR, 1STWHEEL	1	
20	90201-15700	平垫圈 WASHER, PLAIN	1	

图 8 主副轴齿轮

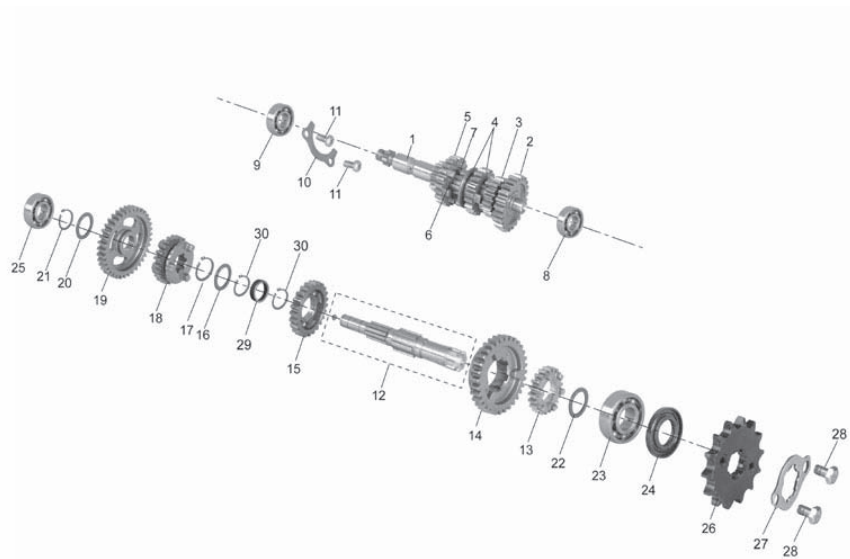
THE MAIN SHAFT GEAR

参照 号码	部品番号	中文名称 英文名称	状态	备注
			2PJ4	
21	99009-15400	卡圈 (轴用) CIRCLIP(S)	1	
22	90201-20272	平垫圈 WASHER, PLAIN	1	
23	93306-204XD	轴承 BRG.	1	
24	93102-20812	油封 SEAL, OIL	1	
25	93306-252XH	轴承 BRG.	1	
26	2PJ-E7451-00	驱动链轮 SPROCKET, DRIVE	1	
27	2PJ-E7456-00	驱动链轮挡圈 HOLDER, DRIVESPROCKET	1	
28	2PJ-RA139-00	内六角圆柱头螺栓 BOLT, HEX.SOCKETHHEAD	2	
29	90387-15803	轴套 COLLAR	1	
30	99009-15400	卡圈 (轴用) CIRCLIP(S)	2	

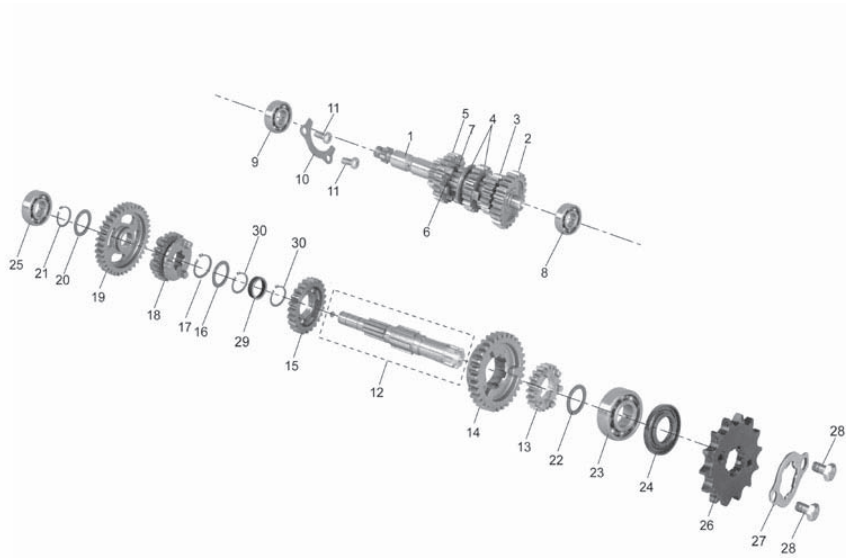



图 9 换挡凸轮 拨叉

SHIFTING CAM SHIFTING FORK

参照 号码	部品番号	中文名称 英文名称	状态	备注
			2PJ4	
1	1SF-E8540-00	换挡凸轮总成 CAM, SHIFT	1	
2	1BK-E8185-00	星型轮 Star Ferry	1	
3	93604-10837	定位销 PIN, DOWEL	2	
4	90151-06818	螺钉 SCREW, C/RECD.C/SUNK	1	
5	2D0-E8511-00	换挡拨叉 1 FORK, SHIFT1	1	
6	2D0-E8512-00	换挡拨叉 2 FORK, SHIFT2	1	
7	2D0-E8513-00	换挡拨叉 3 FORK, SHIFT3	1	
8	5VL-E8531-00	拨叉导杆 1 BAR, SHIFTFORKGUIDE1	1	
9	5VL-E8535-00	拨叉导杆 2 BAR, SHIFTFORKGUIDE2	1	
10	13R-H2540-00	空挡开关组合 NEUTRAL SWITCH ASSY.	1	
11	90154-05802	夹紧螺钉 SCREW, CROSSRECESSED BINDING	2	
12	93210-23801	O 型环 O-RING	1	
13	1JD-E8542-00	空挡触头 Contact gap	1	
14	90501-06805	压簧 Compression	1	

图 10 换挡轴

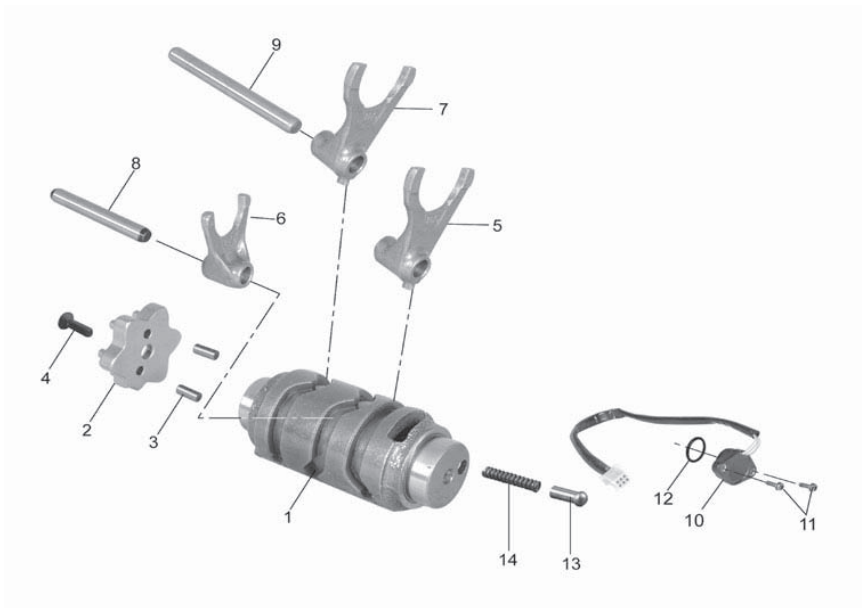
THE GEAR SHIFT SHAFT

参照 号码	部品番号	中文名称 英文名称	状态	备注
			2PJ4	
1	5VL-E8140-00	限位杠杆组合 STOPPERLEVERASSY.	1	
2	5VL-E8337-00	弹力片 SPRG.	1	
3	4FP-E8177-00	限位杠杆螺栓 BOLT, STOPPER2	1	
4	93101-12803	油封 SEAL, OIL	1	
5	90508-32801	扭簧 SPRG., TORSION.	1	
6	99002-10600	卡圈 (E 形) CIRCLIP(E)	1	
7	5VL-E8101-12	变速杆总成 SHIFTSHAFTASSY.	1	
8	93608-30839	定位销 PIN, DOWEL	1	
9	2PJ-E8110-00	换挡踏板总成 CHANGE PEDAL ASSY.	1	
10	2PJ-E8113-00	变速踏杆套 COVER, SHIFTPEDAL	1	
11	2PJ-RA226-00	螺栓 Bolt	1	



图 11 机油泵

THE OIL PUMP

参照 号码	部品番号	中文名称 英文名称	状态	备注
			2PJ4	
1	5VL-E3300-01	机油泵总成 OILPUMPASSY.	1	
2	5VL-E3325-00	. 从动齿轮 . GEAR, DRIVEN	1	
3	99002-05600	. 卡环 . CIRCLIP(E)	1	
4	90201-07641	. 平垫圈 . WASHER, PLAIN	1	
5	90208-07052	. 弹性挡圈 . WASHER, CONICALSPRG.	1	
6	90155-06800	十字槽螺钉 SCREW, C/RECD.FLATFILLISTER	2	
7	90340-12097	螺塞 PLUG, STRAIGHTSCREW	1	
8	90430-12227	垫圈 GASKET	1	
9	2D0-E3411-00	机油过滤网 STRAINER, OIL	1	
10	5VL-E3324-00	驱动齿轮 GEAR, DRIVE	1	
11	5VL-E3451-00	转子过滤器 FILTER, ROTARY	1	



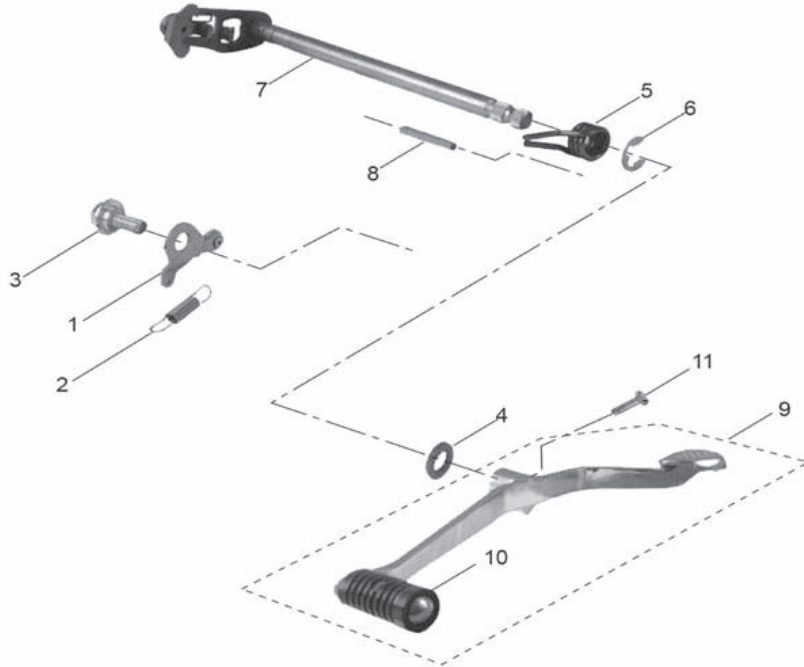
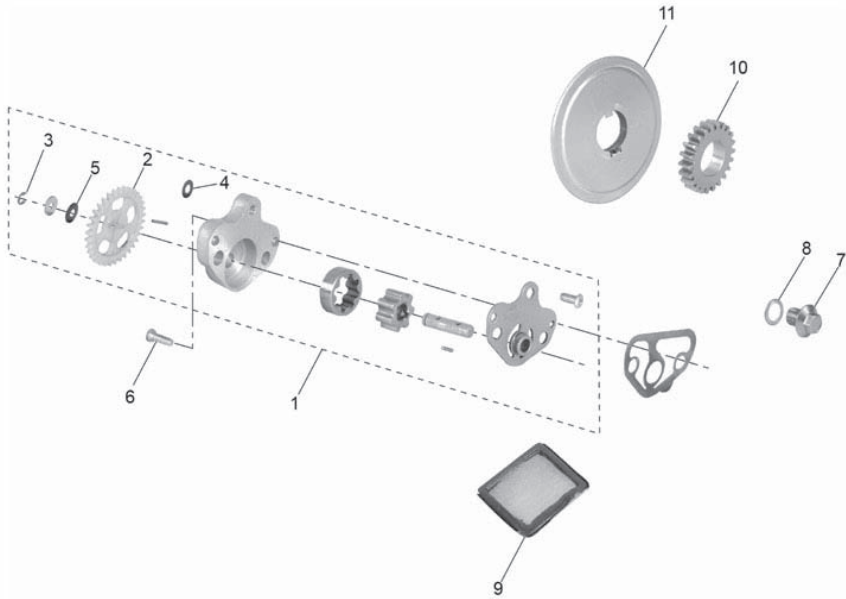

图 12 空气滤清器

AIR FILTER

参照 号码	部品番号	中文名称 英文名称	状态	备注
			2PJ4	
1	2PJ-E4410-00	空气滤清器 Air Filters	1	
2	2PJ-RA224-00	. 带垫螺钉 . Screw with pad	5	
3	2PJ-E4412-00	. 空滤器盖 . Air filter cover	1	
4	2PJ-E4462-00	. 密封条 2 . Seal 2	2	
5	2PJ-E4450-00	. 滤芯总成 . Filter assembly	1	
6	2PJ-E4452-00	. 密封条 1 . Seal 1	1	
7	2PJ-E4411-00	. 空滤器本体组合 . Air filter body combination	1	
8	2PJ-E443E-00	. 排污管 . Sewer	1	
9	2PJ-E3575-00	. 管夹组合 . Pipe clip combination	1	
10	2PJ-E4453-00	. 出气管 . Outlet pipe	1	
11	2PJ-RAC00-00	. 钢丝夹 . Wire clip	1	

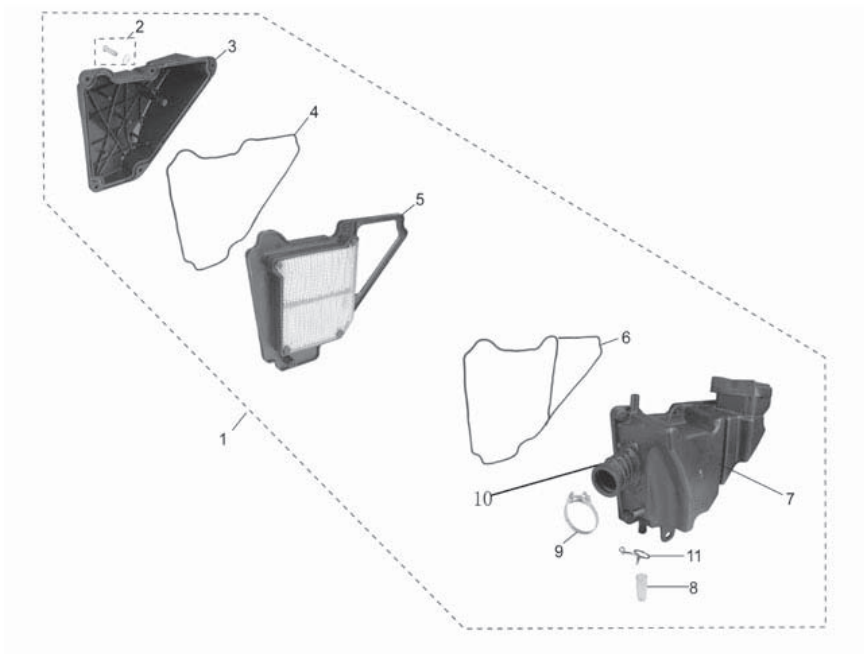

图 13 化油器

CARBURETOR

参照 号码	部品番号	中文名称 英文名称	状态	备注
			2PJ4	
1	2PJ-E4901-00	化油器总成 CARBURETOR ASSY	1	
2	2PJ-E4105-00	. 怠速螺钉工艺组件 ".The idle speed screw process components"	1	
3	2PJ-E4103-00	. PS 螺钉工艺组件 . PS screw process components	1	
4	2PJ-E4141-00	. 主喷管 . Primary nozzle	1	
5	2PJ-E4261-00	. 泡沫管 . Foam pipe	1	
6	2PJ-E4231-00	. 主量孔 . The main gauge hole	1	
7	2PJ-E4142-00	. 怠速量孔 . Idle orifice	1	
8	2PJ-E4112-00	. 节流阀 . Throttle valve	1	
9	2PJ-E490J-00	. 主油针工艺组件 . Main oil needle technology components	1	
10	2PJ-E4589-00	. 真空活塞弹簧 . Vacuum piston spring	1	
11	2PJ-E4150-00	. 针阀组件 . Needle valve components	1	
12	2PJ-E4985-00	. 浮子组件 . Float components	1	
13	2PJ-E4186-00	. 浮子销 . Float pin	1	
14	2PJ-E4147-00	. 浮子室密封垫 . Float chamber seal	1	
15	2PJ-E4191-00	. 放油螺钉 . Oil drain screw	1	
16	2PJ-E4139-00	. 油管卡子 . Tubing clamp	1	
17	2PJ-E4196-00	. 橡胶管 . Rubber hose	1	
18	2PJ-E4216-00	. 浮子室螺钉 M4x16. 带垫 . Float screw M4x16. With pad	3	

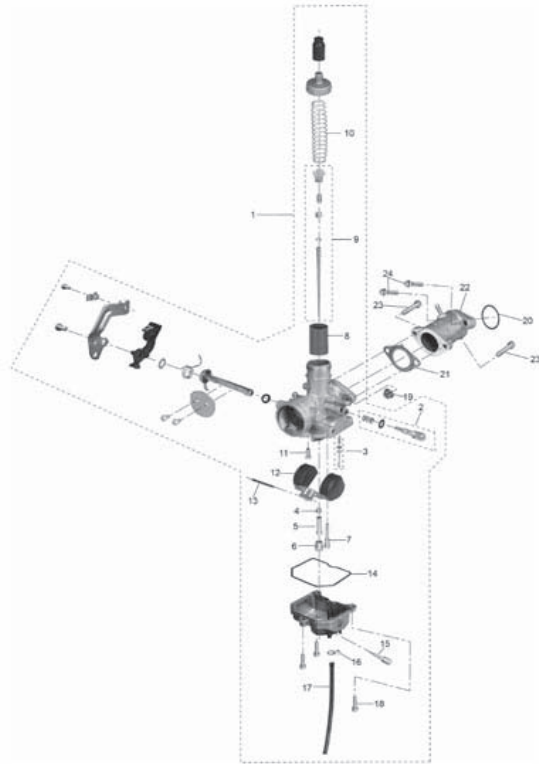

图 13 化油器

CARBURETOR

参照 号码	部品番号	中文名称 英文名称	状态	备注
			2PJ4	
19	2PJ-RA327-00	六角法兰面螺母 Hexagon flange surface nut	2	
20	2PJ-RAF00-00	O 型圈 o-rings	1	
21	2PJ-E3566-00	进气管垫片 Inlet pipe gaskets	1	
22	2PJ-E3586-00	进气管组合 Combination of inlet pipe	1	
23	2PJ-RA152-00	内六角柱头螺钉 Hex head screws	2	
24	2PJ-RA153-00	小六角头法兰面螺栓 Small hexagon flange bolts	2	

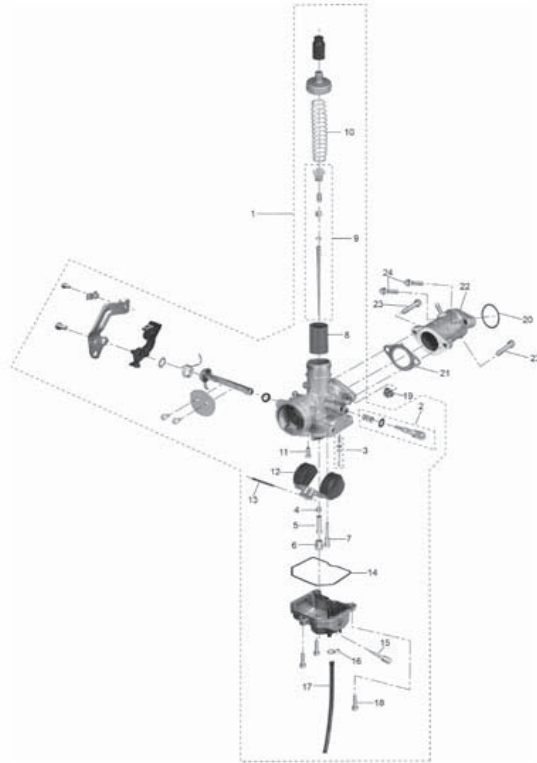

图 14 消声器

MUFFLER

参照 号码	部品番号	中文名称 英文名称	状态	备注
			2PJ4	
1	2PJ-E4710-00	排气消声器组合 Exhaust muffler assy	1	
2	2PJ-E4628-00	. 排气管保护罩 . Outside the exhaust pipe shield	1	
3	2PJ-E4737-00	. 限位垫 . Limit pad	1	
4	2PJ-RA428-00	. 网状垫圈 2 . Mesh 2 washer	5	
5	2PJ-RA427-00	. 网状垫圈 1 . Mesh washer 1	5	
6	2PJ-E4758-00	. 消声器保护罩 . Muffler guard	1	
7	2PJ-RA221-00	. 螺钉 . Screw	5	
8	2PJ-E4613-00	排气管垫圈 Exhaust pipe gasket	1	
9	2PJ-RA148-00	内六角圆柱头螺钉 Screw	2	

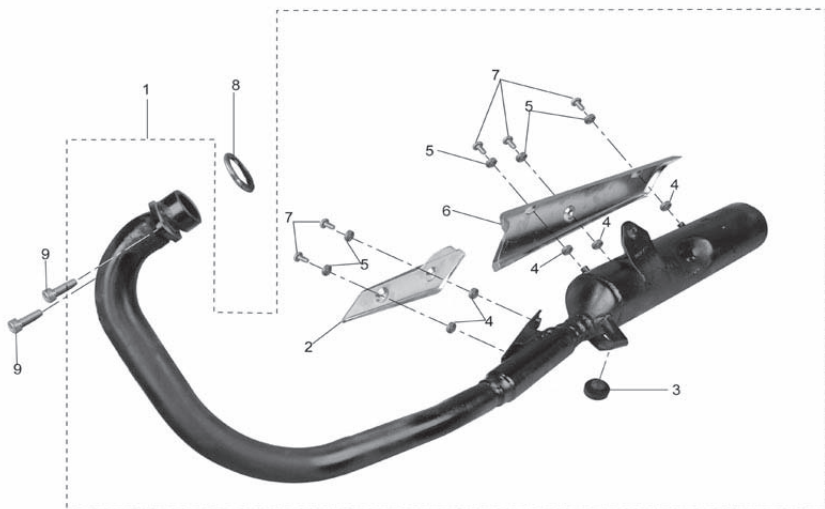

图 15 电启动系统

ELECTRICAL STARTING SYSTEM

参照 号码	部品番号	中文名称 英文名称	状态	备注
			2PJ4	
1	2PJ-H1800-00	启动电动机 STARTINGMOTORASSY.	1	
2	2PJ-H1801-00	. 碳刷组合 . Carbon brush combination	1	
3	2PJ-H182M-00	. O 形圈 3 . O-ring 3	2	
4	2PJ-H182L-00	. O 形圈 1 . O-ring 1	1	
5	2PJ-H182A-00	. 六角薄螺母 (铜) . NUT, TERMIANL	1	
6	2PJ-H182K-00	. 全金属六角法兰面锁紧螺母 . All metal hexagonal flange lock nut	1	
7	2PJ-H183G-00	. 线束 . CORD COMP.	1	
8	2PJ-RA153-00	小六角头法兰面螺栓 BOLT, FLG.(SMALLHEAD)	2	
9	5VL-E5521-00	轴 1 SHAFT, 1	1	
10	5VL-E5512-00	惰轮 GEAR, IDLER1	1	
11	5VL-E5532-00	惰齿轮 PLATE, IDLERGEAR	1	
12	98512-06012	十字槽盘头螺钉 SCREW, PANHEAD(+)	2	
13	1SF-H1450-20	转子总成 ROTORASSY.	1	
14	90201-258D7	平垫圈 WASHER, PLAIN	1	
15	5VL-E5517-00	惰齿轮 GEAR, IDLER2	1	
16	91312-08016	内六角圆柱头螺钉 BOLT, HEX.SOCKETHHEAD	3	
17	1BK-E5580-00	离合器外端 STARTERCLUTCHOUT.ASSY.	1	
18	1SF-H1410-20	定子总成 STATORASSY.	1	
19	91312-06014	内六角圆柱头螺钉 BOLT, HEX.SOCKETHHEAD	2	
20	91312-06025	内六角柱头螺栓 BOLT, HEX.SOCKETHHEAD	3	

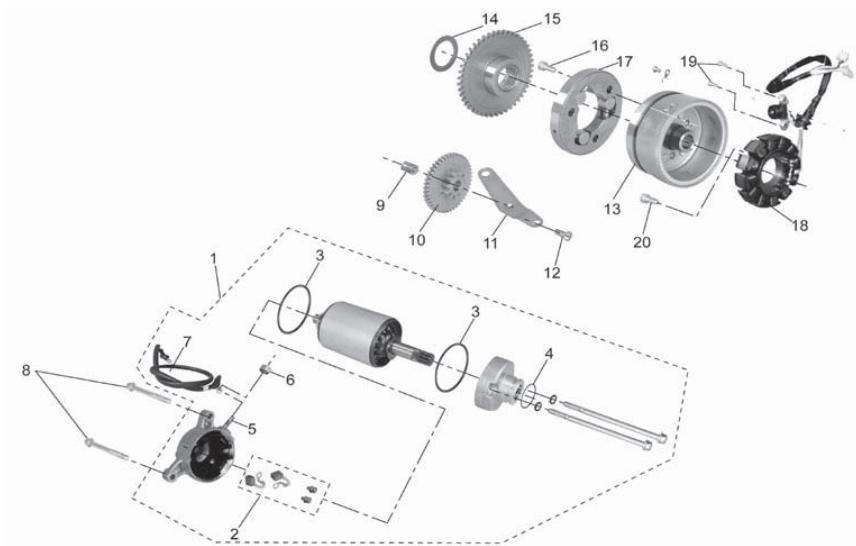

图 16 脚启动系统

KICK STARTING SYSTEM

参照 号码	部品番号	中文名称 英文名称	状态	备注
			2PJ4	
1	5VL-E5660-01	启动轮轴组合 KICK SHAFT ASSY.	1	
2	4FP-E5641-00	启动齿轮 GEAR, KICK	1	
3	90468-26813	卡环 CLIP	1	
4	90201-208D5	平垫圈 WASHER, PLAIN	1	
5	90508-26836	扭簧 SPRG., TORSION	1	
6	4FP-E5666-00	衬套 SPACER	1	
7	5VL-E5651-00	启动空转齿轮 GEAR, SPROCKET IDLE	1	
8	90201-152H7	平垫圈 WASHER, PLAIN	2	
9	99009-15400	卡环 CIRCLIP(S)	2	
10	2PJ-E5620-00	启动曲柄组合 KICK CRANK ASSY.	1	
11	2PJ-E5618-00	启动蹬杆套 COVER	1	
12	90179-12813	螺母 NUT	1	
13	93109-20806	油封 SEAL, OIL	1	

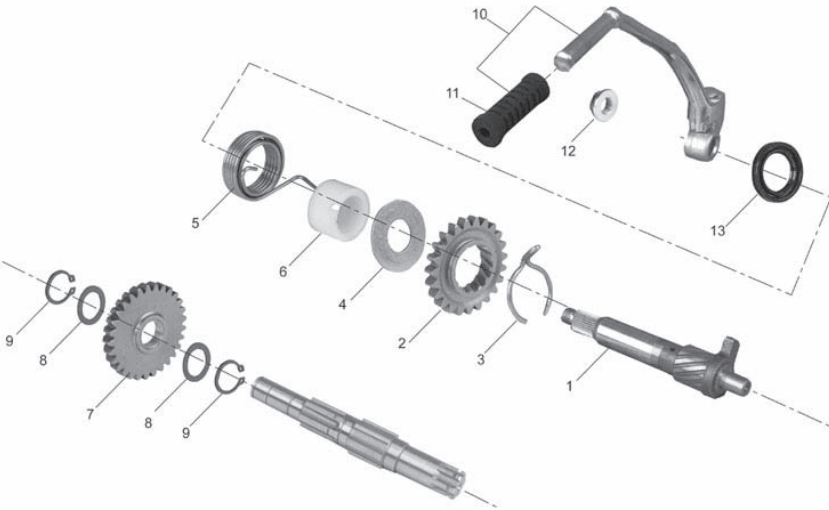

图 17 车架

FRAME

参照 号码	部品番号	中文名称 英文名称	状态	备注
			2PJ4	
1	2PJ-F4444-00	十字槽小盘头螺钉 SCREW	1	
2	2PJ-F4399-00	离合器线夹 BAND 2	1	
3	2PJ-F1110-W0	车架打刻 FRAME COMP.	1	
	2PJ-F1110-00	车架涂装 FRAME COMP.	1	
4	2PJ-F4181-00	定位减震垫 1 DAMPER, LOCATING 1	2	
5	2PJ-F4182-00	定位减震垫 3 DAMPER, LOCATING 2	1	
6	2PJ-RA143-00	六角头螺栓和大垫圈组合件 BOLT, HEX. M6X16	3	
7	2PJ-F8100-00	随车工具 TOOL KIT	1	
8	2PJ-F811G-00	O 形圈 BAND	1	
9	2PJ-F177G-00	蓄电池盒 BOX, BATTERY	1	
10	2PJ-RA165-00	六角法兰面螺栓 BOLT, FLG. M8X100	1	
11	2PJ-RA166-00	六角法兰面螺栓 BOLT, FLG. M8X110	1	
12	2PJ-RA332-00	六角法兰面螺母 NUT, FLG. M8	7	
13	2PJ-RA163-00	六角法兰面螺栓 BOLT, FLG. M8X60	2	
14	2PJ-RA161-00	六角法兰面螺栓 BOLT, FLG. M8X40	1	
15	2PJ-F1318-00	发动机支承 3 STAY, ENGINE 4	1	
16	2PJ-F1317-00	发动机右上连接板组合 STAY, ENGINE 3	1	
17	2PJ-RA167-00	六角法兰面螺栓 BOLT, FLG. M10X80	2	
18	2PJ-RA164-00	六角法兰面螺栓 BOLT, FLG. M8X75	2	
19	2PJ-F1316-00	发动机支架 2 STAY, ENGINE 2	1	

图 17 车架

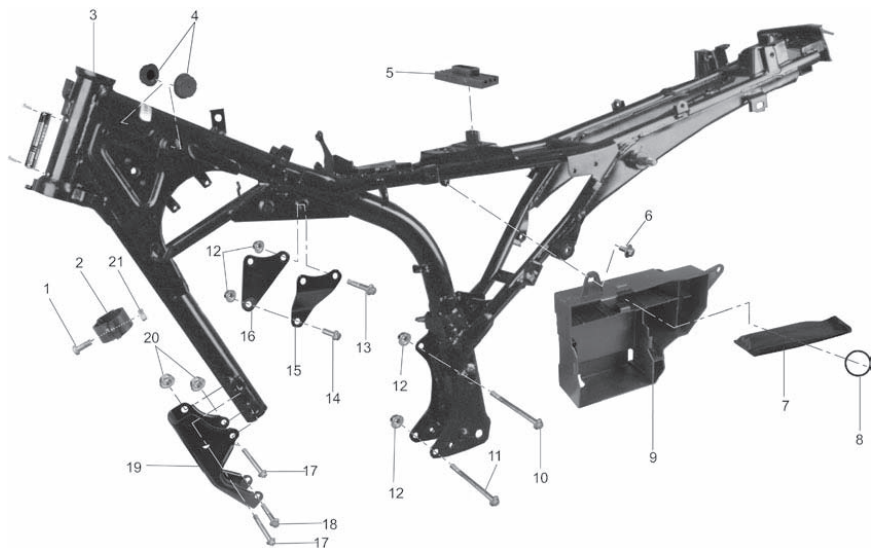
FRAME

参照 号码	部品番号	中文名称 英文名称	状态	备注
			2PJ4	
20	2PJ-RA335-00	六角法兰面螺母 NUT, FLG. M10	2	
21	2PJ-F4477-00	六角螺母 NUT	1	

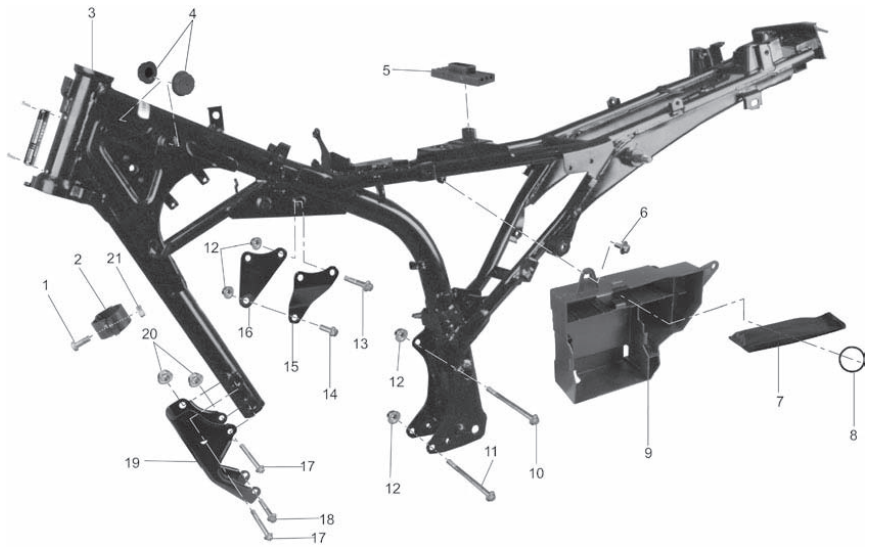



图 18 二次进气

GAS CIRCULATE SYSTEM

参照 号码	部品番号	中文名称 英文名称	状态	备注
			2PJ4	
1	2PJ-RAC08-00	钢丝夹 Φ8 CLIP, 4	7	
2	2PJ-F4314-00	单向阀管 2 PIPE, 4	1	
3	2PJ-F4315-00	单向阀管 1 PIPE, 5	1	
4	2PJ-F4682-00	单向阀 VALVE	1	
5	2PJ-F4316-00	炭罐溢流管 PIPE, 6	3	
6	2PJ-F4180-00	翻车阀 ROLL OVER VALVE ASSY.	1	
7	2PJ-F4312-00	脱附管 PIPE, 2	1	
8	2PJ-RA140-00	六角法兰面螺栓 BLOT	1	
9	2PJ-F4398-00	炭罐抱箍 CANISTER ASSY. SETTING	1	
10	2PJ-F4170-00	炭罐总成 CANISTER ASSY.	1	
11	2PJ-RA224-00	螺钉和平垫圈组合件 SCREW M6X20	2	
12	2PJ-RA144-00	内六角圆柱头螺钉 BOLT, HEX. SOCKET M6X16	2	
13	2PJ-E4871-00	弯管组合 PIPE, 1	2	
14	2PJ-E4883-00	负压管组合 HOSE, BEND 3	1	
15	2PJ-E4803-00	二次补气阀 AIR INDUCTION SYSTEM ASSY.	1	
16	2PJ-E4815-00	弯管垫片 GASKET	1	
17	2PJ-E4882-00	补气管 2 HOSE, BEND 2	1	
18	2PJ-E4881-00	补气管 1 HOSE, BEND 1	1	
19	2PJ-F4313-00	翻车阀管 1 PIPE, 3	2	
20	2PJ-RAC08-00	钢丝夹 CLIP, 7	5	

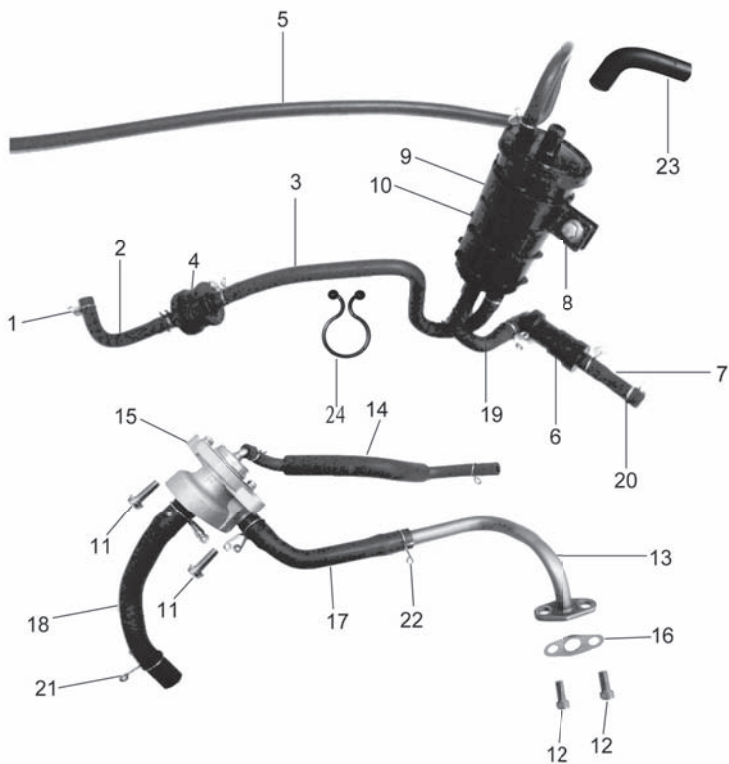

图 18 二次进气

GAS CIRCULATE SYSTEM

参照 号码	部品番号	中文名称 英文名称	状态	备注
			2PJ4	
21	2PJ-RAC00-00	钢丝夹 CLIP, 1	3	
22	2PJ-RAC07-00	卡箍 CLIP, 6	1	
23	2PJ-F4317-00	通气管 PIPE, 7	1	
24	2PJ-F4135-00	线夹 CLAMP, 1	1	

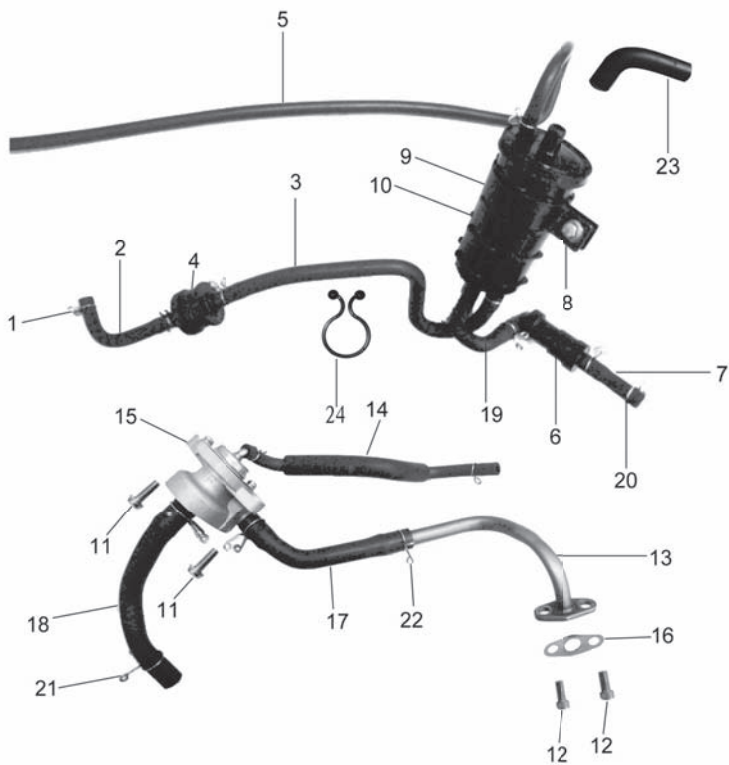

图 19 挡泥板

FENDER

参照 号码	部品番号	中文名称 英文名称	状态	备注
			2PJ4	
1	2PJ-RA147-00	六角头螺栓与平垫圈组合件 BOLT, HEX. M6X16	4	
2	2PJ-F472K-00-P0	右尾罩 COVER, TAIL 2	1	UR 红色车用 UR FPR RED
	2PJ-F472K-00-P1	右尾罩 COVER, TAIL 2	1	UR 黑色车用 UR FOR BLACK
	2PJ-F472K-00-P2	右尾罩 COVER, TAIL 2	1	UR 蓝色车用 UR FOR BLUE
3	2PJ-F471K-00-P0	左尾罩 COVER, TAIL 1	1	UR 红色车用 UR FPR RED
	2PJ-F471K-00-P1	左尾罩 COVER, TAIL 1	1	UR 黑色车用 UR FOR BLACK
	2PJ-F471K-00-P2	左尾罩 COVER, TAIL 1	1	UR 蓝色车用 UR FOR BLUE
4	2PJ-F1773-00	油箱后支承胶圈 GROMMET	2	
5	2PJ-RA340-00	弹性螺母 NUT, SPRG. M5	1	
6	2PJ-RA229-00	自攻螺钉 SCREW	1	
7	2PJ-F4785-00	尾罩嵌条 MOLE	1	
8	2PJ-F4796-00	尾罩胶垫 COVER, 1	1	
9	2PJ-F1637-00	线夹 4 CLAMP, WIRE	2	
10	2PJ-F1621-00	后挡泥板檐板 FLAP	1	
11	2PJ-F1685-00	后牌照支架组合 BRKT., LICENSE	1	
12	2PJ-H5130-00	后反光片组合 RR. REFLECTOR ASSY., 1	1	
13	2PJ-RA421-00	大垫圈 WASHER 5	1	
14	2PJ-RA422-00	弹簧垫圈 WASHER 5	1	
15	2PJ-RA325-00	六角螺母 NUT, HEX. M5	1	
16	2PJ-RA141-00	六角头螺栓和平垫圈组合 BOLT, HEX. M6X12	2	

图 19 挡泥板

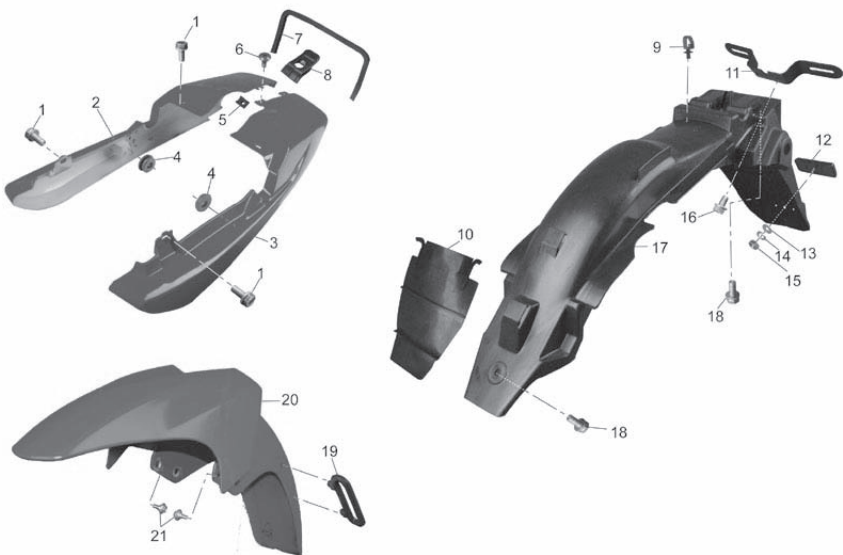
FENDER

参照 号码	部品番号	中文名称 英文名称	状态	备注
			2PJ4	
17	2PJ-F1611-00	后挡泥板 FENDER	1	
18	2PJ-RA143-00	六角头螺栓和大垫圈组合件 Hexagon head bolt	3	
19	2PJ-F1518-00	拉索导框 HOLDER, WIRE	1	
	2PJ-F1511-00-P0	前挡泥板 FENDER	1	UR 红色车用 UR FPR RED
20	2PJ-F1511-00-P1	前挡泥板 Front fender	1	UR 黑色车用 UR FOR BLACK
	2PJ-F1511-00-P2	前挡泥板 Front fender	1	UR 蓝色车用 UR FOR BLUE
21	2PJ-F1531-00	前叉螺栓 BOLT, 1	4	

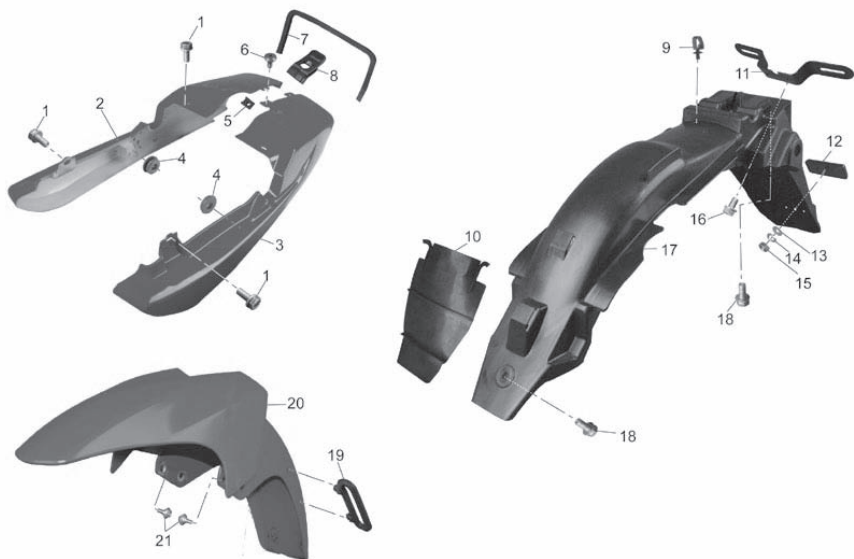



图 20 挡泥板

FENDER

参照 号码	部品番号	中文名称 英文名称	状态	备注
			2PJ4	
1	2PJ-F1721-00-P0	右侧盖组合 COVER, SIDE 2	1	UR 红色车用 UR FPR RED
	2PJ-F1721-00-P1	右侧盖组合 COVER, SIDE 2	1	UR 黑色车用 UR FOR BLACK
	2PJ-F1721-00-P2	右侧盖组合 COVER, SIDE 2	1	UR 蓝色车用 UR FOR BLUE
2	2PJ-F1778-00	定位减震垫 1 DAMPER, LOCATING 1	2	
3	2PJ-F1711-00-P0	左侧盖组合 COVER, SIDE	1	UR 红色车用 UR FPR RED
	2PJ-F1711-00-P1	左侧盖组合 COVER, SIDE	1	UR 黑色车用 UR FOR BLACK
	2PJ-F1711-00-P2	左侧盖组合 COVER, SIDE	1	UR 蓝色车用 UR FOR BLUE
4	2PJ-F1708-00	侧盖锁 LOCK	1	
5	2PJ-F1773-00	油箱后支承胶圈 GROMMET	2	
6	2PJ-RA431-00	大垫圈 Great washer	1	
7	2PJ-RA227-00	螺钉 SCREW M6X20	1	

图 21 方向把、拉索

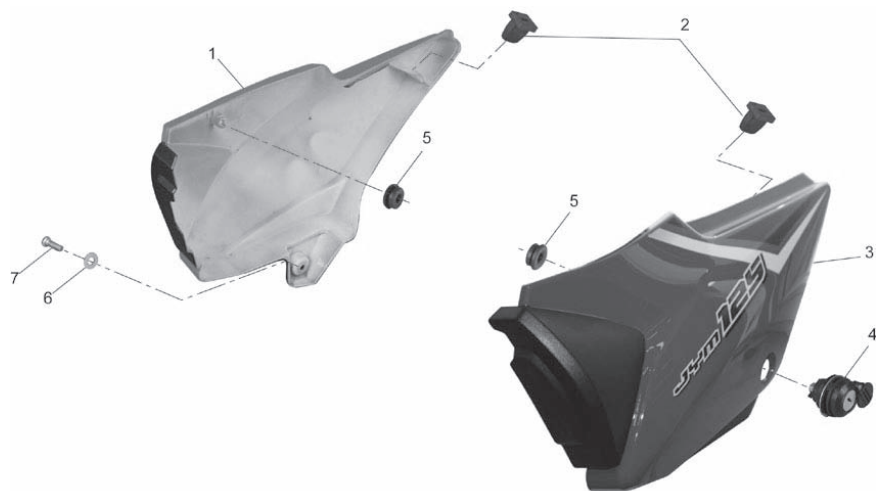
STEERING HANDLE & CABLE

参照 号码	部品番号	中文名称 英文名称	状态	备注
			2PJ4	
1	2PJ-F6311-00	油门拉索 WIRE, THROTTLE 1	1	
2	2PJ-F632G-00	螺钉 M5x14 SCREW M5X10	1	
3	2PJ-F6341-00	前制动拉索 WIRE, BRAKE 1	1	
4	2PJ-F6348-00	压簧 1 SPRG., ADJUSTING	1	
5	2PJ-F6111-00	手把管 HANDLE	1	
6	2PJ-F6241-00	左握把 GRIP, 1	1	
7	2PJ-RAY00-00	销柱 PIN, 1	1	
8	2PJ-F6353-00	调整螺母 NUT, ADJ.	1	
9	2PJ-F6331-00	阻风门拉索 WIRE, STARTER	1	
10	2PJ-F6335-00	离合器拉索 WIRE, CLUTCH	1	
11	2PJ-F6240-00	右握把组件 GRIP ASSY.	1	
12	2PJ-F6290-00	右后视镜组合 MIRROR ASSY., 2	1	
13	2PJ-F6280-00	左后视镜组合 MIRROR ASSY., 1	1	
14	2PJ-F6372-00	护套 COVER, LEVER	2	

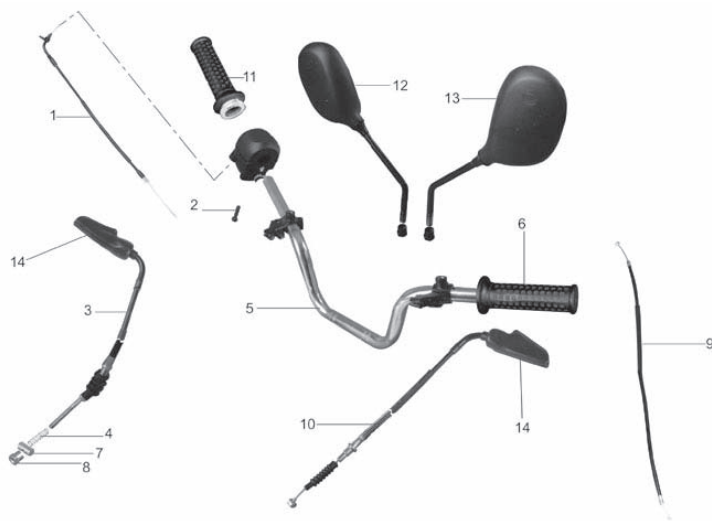



图 22 手把开关

HANDLE SWITCH & LEVER

参照 号码	部品番号	中文名称 英文名称	状态	备注
			2PJ4	
1	2PJ-H3975-00	右手把开关组合 SW., HANDLE 2	1	
2	2PJ-RA217-00	. 螺钉 . SCREW M5X20	2	
3	2PJ-RA218-00	. 螺钉 . SCREW M5X44	2	
4	2PJ-H2921-00	右手柄座 HOLDER, LEVER 2	1	
5	2PJ-F6343-00	紧固螺母 NUT, ADJUSTING 1	2	
6	2PJ-H3980-00	前刹开关 FR. STOP SWITCH ASSY.	1	
7	2PJ-F6345-00	拉索调整螺管 BOLT, ADJUSTING	2	
8	2PJ-RA426-00	平垫圈 WASHER 8	2	
9	2PJ-H2917-00	离合器开关 SW.	1	
10	2PJ-RA420-00	标准型弹簧垫圈 WASHER 6	2	
11	2PJ-H2911-00	左手柄座 HOLDER, LEVER 1	1	
12	2PJ-H3973-00	左手把开关组合 SW., HANDLE 3	1	
13	2PJ-H3912-00	左手柄 LEVER, 1	1	
14	2PJ-H3941-00	. 风门手柄组合 . LEVER, STARTER	1	
15	2PJ-H3915-00	. 螺钉 . SCREW, LEVER FITTING	2	
16	2PJ-RA329-00	锁紧薄螺母 NUT, FLG. M6	2	
17	2PJ-H3945-00	螺栓 BOLT, LEVER	2	
18	2PJ-RA151-00	六角法兰面螺栓 BOLT, FLG. M6X20	2	
19	2PJ-H2593-00	手把管箍带 BAND	2	
20	2PJ-H3922-00	右手柄 LEVER, 2	1	

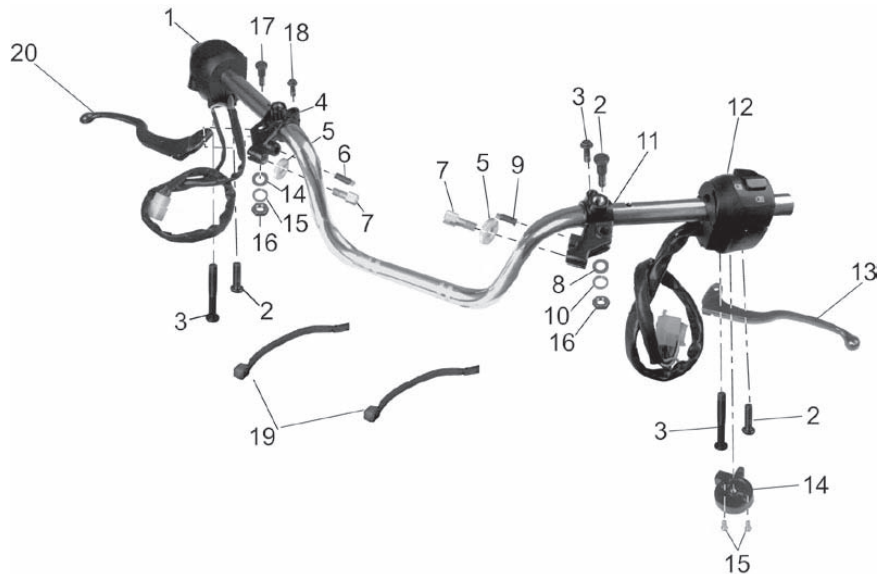

图 23 前叉

FRONT FORK

参照 号码	部品番号	中文名称 英文名称	状态	备注
			2PJ4	
1	2PJ-F3174-00	前照灯支架 STAY, HEAD LIGHT	1	
2	2PJ-F317J-00	前大灯胶套 DAMPER, 1	2	
3	2PJ-RA162-00	六角法兰面螺栓 BOLT, FLG. M8X40	2	
4	2PJ-F3435-00	手把座 CROWN, HANDLE	1	
5	2PJ-F3441-00	手把夹持器 HOLDER, HANDLE UPPER	2	
6	2PJ-RA133-00	六角法兰面螺栓 BOLT, FLG. M8X35	4	
7	2PJ-F3165-00	垫圈 WASHER	1	
8	2PJ-F3454-00	方向柱锁紧螺母 NUT, FITTING 2	1	
9	2PJ-F334G-00	前装饰牌支承 BRKT., 1	1	
10	2PJ-F3418-00	方向柱限位卡垫 WASHER, SPECIAL	1	
11	2PJ-F3453-00	方向柱调节螺母 NUT, FITTING 1	2	
12	2PJ-F3444-00	方向柱减震胶垫 WASHER	1	
13	2PJ-F3416-00	轴承座圈盖组合 COVER, BALL RACE 2	1	
14	2PJ-F3411-00	上轴承挡圈 RACE, BALL 1	1	
15	2PJ-F341E-00	保持架 RETAINER, BALL BEARING	2	
16	2PJ-F3412-00	上轴承座圈 RACE, BALL 2	1	
17	2PJ-F3414-00	下轴承座圈 RACE, BALL 4	1	
18	2PJ-F3413-00	下轴承挡圈 RACE, BALL 3	1	
19	2PJ-F3346-00	螺栓弹垫垫圈组合 BOLT, 1	2	
20	2PJ-F331X-00	下转向座组合 BRKT., UNDER	1	

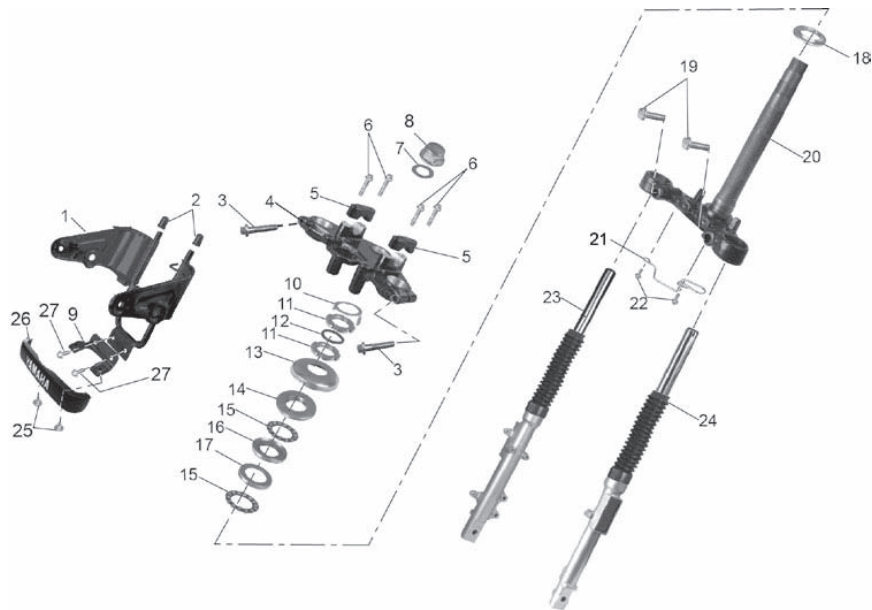

图 23 前叉

FRONT FORK

参照 号码	部品番号	中文名称 英文名称	状态	备注
			2PJ4	
21	2PJ-F3389-00	电缆线卡 GUIDE, WIRE	1	
22	2PJ-RA135-00	六角法兰面螺栓 BOLT, FLG. M6X20	2	
23	2PJ-F3103-00	右前减震器 DAMPER ASSY., RH.	1	
24	2PJ-F3102-00	左前减震器 DAMPER ASSY., LH.	1	
25	2PJ-RA230-00	螺钉垫圈组合 SCREW M5X12	2	
26	2PJ-F3395-00	前装饰牌 EMBLEM	1	
27	2PJ-RA146-00	六角法兰面螺栓 BOLT, FLG. M6X16	2	

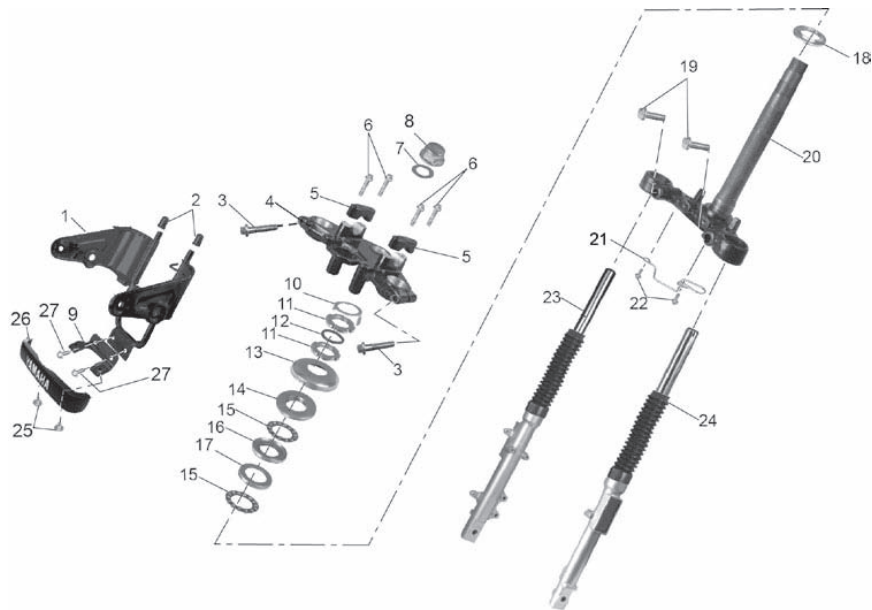

图 24 前减震器

FRONT SHOCK ABSORBER

参照 号码	部品番号	中文名称 英文名称	状态	备注
			2PJ4	
1	2PJ-F3102-00	左前减震器 DAMPER ASSY., LH.	1	
2	2PJ-F3106-00	. 左底筒组件 . TUBE ASSY., LH.	1	
3	2PJ-F3145-00	. 油封 30x40.5x10.5 . SEAL, DUST	2	
4	2PJ-F3144-00	. 防尘盖 . Anti-dust	2	
5	2PJ-F3170-00	. 活塞管 . Position control	2	
6	2PJ-F3152-00	. 缓冲弹簧 . Buffer spring	2	
7	2PJ-F3157-00	. 活塞环 . Piston Ring	2	
8	2PJ-F3141-00	. 减震弹簧 . Shock springs	2	
9	2PJ-F3118-00	. DU 衬套 . DU bush	2	
10	2PJ-F3146-00	. 衬套垫圈 . Washer	2	
11	2PJ-F3111-00	. 端盖组件 . PLUG ASSY.	2	
12	2PJ-H5110-00	. 反光片 . FR. REFLECTOR ASSY., 1	2	
13	2PJ-F3110-00	. 前叉管 . FORK PIPE	2	
14	2PJ-F3191-00	. 防尘套管 . BOOT	2	
15	2PJ-F3192-00	. 卡子 . BAND	2	
16	2PJ-F3103-00	右前减震器 Right front shock absorber	1	
17	2PJ-F3107-00	. 右底筒组件 . TUBE ASSY., RH.	1	

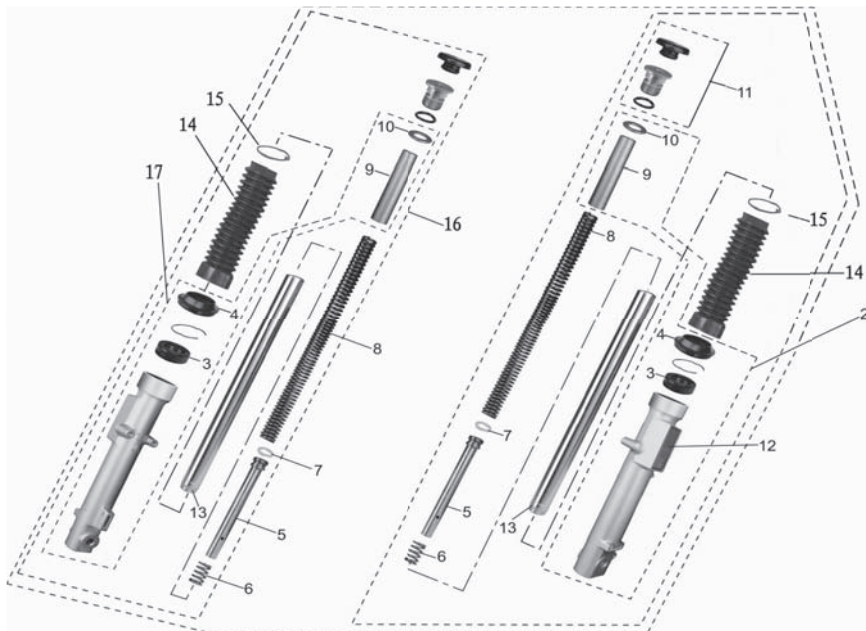

图 25 后轮悬挂

REAR SUSPENSION

参照 号码	部品番号	中文名称 英文名称	状态	备注
			2PJ4	
1	2PJ-F2210-00	后减震器 SHOCK ABSORBER, RR.	2	
2	2PJ-F2243-00	平垫圈 WASHER, 1	4	
3	2PJ-RA336-00	盖型螺母 NUT, CAP M10	4	
4	2PJ-RA222-00	螺钉垫圈组合 SCREW M6X14	2	
5	2PJ-F2311-00	链盒组件 CASE, CHAIN 1	1	
6	2PJ-F5378-00	螺栓 BOLT, TENSION BAR 2	1	
7	2PJ-F5371-00	后制动撑杆 BAR, TENSION	1	
8	2PJ-RA424-00	弹簧垫圈 WASHER 8	1	
9	2PJ-RA331-00	六角螺母 NUT, HEX. M8	1	
10	2PJ-RAY02-00	开口销 PIN, 2	1	
11	2PJ-F2141-00	后臂轴 SHAFT, PIVOT	1	
12	2PJ-F2128-00	盖 1 Cover 1	2	
13	2PJ-F2151-00	链条保护罩 SEAL, GUARD	1	
14	2PJ-F2124-00	衬套 1 BUSH., 2	2	
15	2PJ-F2123-00	衬套 BUSH., 1	2	
16	2PJ-F2184-00	衬套 BUSH.	2	
17	2PJ-F2110-00	后臂焊接 RR. ARM COMP.	1	
18	2PJ-RA338-00	锁紧螺母 NUT, U FLG. M12	1	

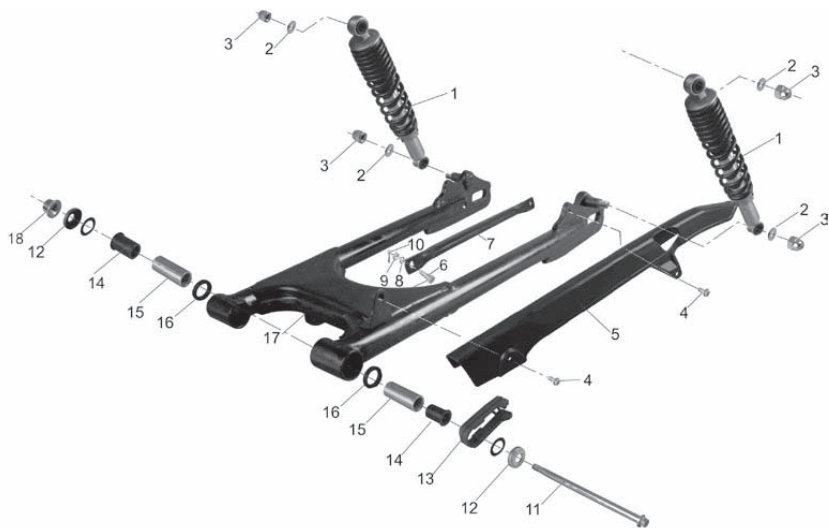

图 26 主支架、搁脚

STAND & FOOTREST

参照 号码	部品番号	中文名称 英文名称	状态	备注
			2PJ4	
1	2PJ-F7452-00	左后搁脚托架 BRKT., FOOTREST 1	1	
2	2PJ-F7112-00	主支架轴 SHAFT	1	
3	2PJ-F7431-00	右后搁脚芯轴组合 FOOTREST, REAR 2	2	
4	2PJ-F7433-00	后搁脚套 COVER, REAR FOOTREST 2	2	
5	2PJ-F7445-00	挡圈 PLATE, 1	2	
6	2PJ-F7438-00	后搁脚连接销 PIN	2	
7	2PJ-F7462-00	右后搁脚托架 BRKT., FOOTREST 2	1	
8	2PJ-RA425-00	平垫圈 WASHER 8	2	
9	2PJ-RAY08-00	开口销 PIN, 4	2	
10	2PJ-RA157-00	六角法兰面螺栓 BOLT, FLG. M8X20	2	
11	2PJ-F7413-00	搁脚套 COVER, FOOTREST	1	
12	2PJ-F7411-00	主搁脚总成 FOOTREST	1	
13	2PJ-F7318-00	锁紧螺母 NUT	1	
14	2PJ-F7317-00	侧支架螺栓 BOLT	1	
15	2PJ-F7316-00	侧支架拉簧 SPRG.	1	
16	2PJ-F7311-00	侧支架 STAND, SIDE	1	
17	2PJ-F7211-00	后制动踏板 PEDAL, BRAKE	1	
18	2PJ-RAY07-00	开口销 PIN, 3	1	
19	2PJ-F7216-00	后制动扭转簧 SPRG., RETURN	1	
20	2PJ-F7119-00	垫圈 1 WASHER	2	

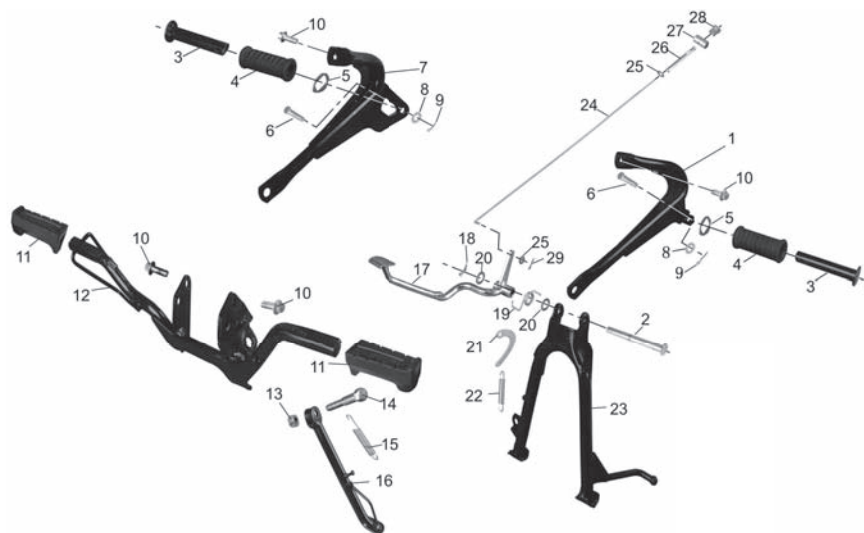

图 26 主支架、搁脚

STAND & FOOTREST

参照 号码	部品番号	中文名称 英文名称	状态	备注
			2PJ4	
21	2PJ-F7115-00	挂板 LINK	1	
22	2PJ-F7116-00	主支架拉簧 SPRG.	1	
23	2PJ-F7111-00	主支架 STAND, MAIN	1	
24	2PJ-F7231-00	拉杆 ROD, BRAKE	1	
25	2PJ-RA418-00	平垫圈 WASHER 6	2	
26	2PJ-F7236-00	压簧 SPRG., ROD	1	
27	2PJ-RAY00-00	销柱 PIN, 1	1	
28	2PJ-F6353-00	调整螺母 NUT, ADJ.	1	
29	2PJ-RAY02-00	开口销 PIN, 2	1	

图 27 油箱

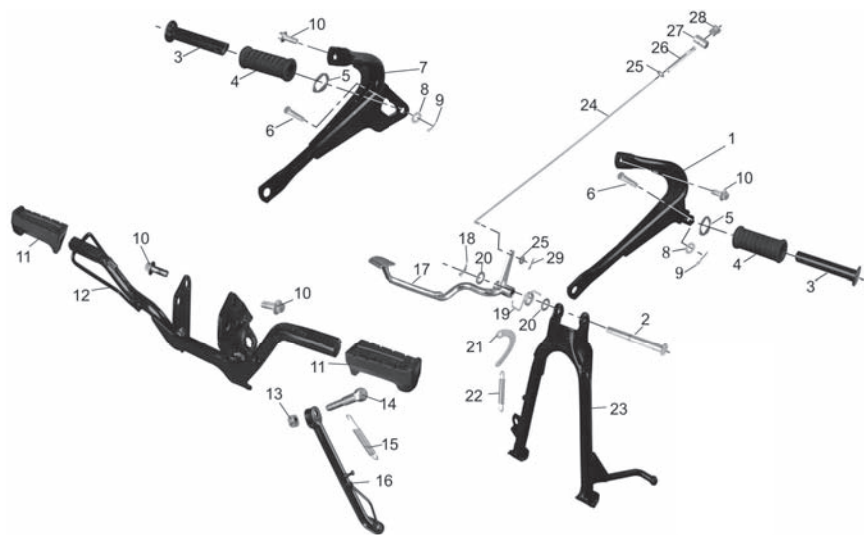
FUEL TANK

参照 号码	部品番号	中文名称 英文名称	状态	备注
			2PJ4	
1	2PJ-F4318-00	油箱溢流管 TANK PIPE	1	
2	2PJ-RA142-00	六角法兰面螺栓 BOLT, FLG. M6X14	4	
3	2PJ-H5752-00	燃油传感器组合 SENDER	1	
4	2PJ-H5753-00	油封圈 GSKT.	1	
5	2PJ-F4605-00	油箱锁 CAP ASSY.	1	
6	2PJ-RA216-00	螺钉 SCREW M5X20	3	
7	2PJ-RA214-00	螺钉 SCREW M5X10	1	
8	2PJ-RA213-00	螺钉 SCREW M5X8	4	
	2PJ-F4110-00-P0	油箱体 FUEL TANK COMP.	1	UR 红色车用 UR FPR RED
9	2PJ-F4110-00-P1	油箱体 FUEL TANK COMP.	1	UR 黑色车用 UR FOR BLACK
	2PJ-F4110-00-P2	油箱体 FUEL TANK COMP.	1	UR 蓝色车用 UR FOR BLUE
10	2PJ-F4176-00	六角法兰面螺栓 BOLT, 1	1	
11	2PJ-F4186-00	油箱安装垫圈 WASHER, SPECIAL	1	
12	2PJ-F4183-00	定位防震垫 2 DAMPER, LOCATING 3	1	
13	2PJ-F4500-00	燃油开关组合 FUEL COCK ASSY.	1	
14	2PJ-RA224-00	螺钉垫圈组合 SCREW M6X20	2	
15	2PJ-RAC05-00	钢丝夹 $\phi 8$ CLIP, 4	2	
16	2PJ-F4311-00	油管 PIPE, FUEL	1	
17	2PJ-F4522-00	垫圈 6 GSKT.	2	
18	2PJ-F4512-00	密封垫圈 GSKT.	1	



图 27 油箱

FUEL TANK

参照 号码	部品番号	中文名称 英文名称	状态	备注
			2PJ4	
19	2PJ-F4522-00	垫圈 6 GSKT.	4	





图 28 座垫

SEAT

参照 号码	部品番号	中文名称 英文名称	状态	备注
			2PJ4	
1	2PJ-F4730-00	座垫 DBL. SEAT ASSY.	1	
2	2PJ-F4741-00	. 缓冲垫 . PAD, SEAT	6	
3	2PJ-RA143-00	六角头螺栓和大垫圈组合件 BOLT, HEX. M6X16	2	
4	2PJ-RA156-00	六角法兰面螺栓 BOLT, FLG. M8X16	3	
5	2PJ-F4840-00	小货架 CARRIER ASSY.	1	

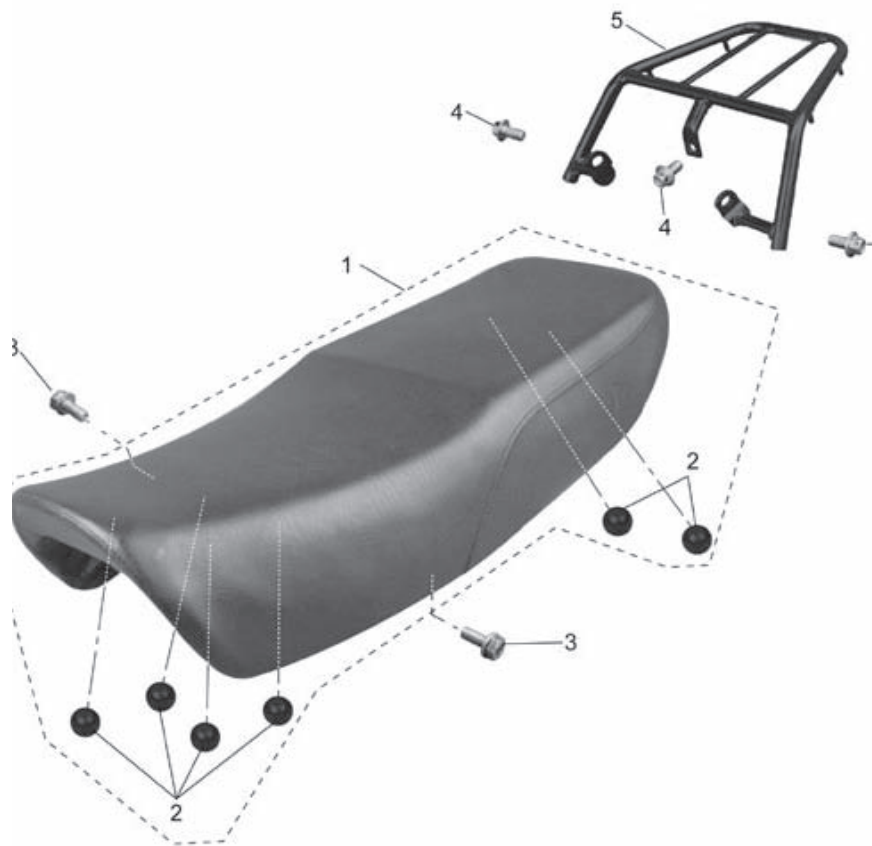

图 29 前压铸轮

FRONT WHEEL FOR CAST WHEEL

参照 号码	部品番号	中文名称 英文名称	状态	备注
			2PJ4	
1	2PJ-F5181-00	前轮轴 AXLE, WHEEL FR.	1	
2	2PJ-F5183-10	前轮右衬套 COLLAR, WHEEL SHAFT 1	1	
3	2PJ-F510S-00	前轮外胎 TIRE	1	
4	2PJ-F510T-00	前轮内胎 TUBE	1	
5	2PJ-RAY23-00	油封 SEAL, OIL 6	1	
6	2PJ-RAY01-00	滚动轴承 BEARING, 1	2	
7	2PJ-F5117-10	衬套 SPACER, BEARING	1	
8	2PJ-F5115-00	主支承圈 FLG., SPACER1	1	
9	2PJ-F5168-00	前轮毂组合 WHEEL, CAST	1	
10	2PJ-F5121-20	前制动盖 PLATE, BRAKE SHOE	1	
11	2PJ-F5135-10	驱动齿轮 GEAR, DRIVE	1	
12	2PJ-RA429-00	平垫圈 WASHER	1	
13	2PJ-RAY24-00	油封 WASHER	1	
14	2PJ-RAD04-00	拉簧 SPRING, TENSION 3	2	
15	2PJ-WF530-10	前制动蹄块组合 BRAKE SHOE COMP., 1	1	
16	2PJ-F5351-10	前制动凸轮轴 CAM, SHAFT 1	1	
17	2PJ-RAY17-00	密封垫 GSKT., 2	1	
18	2PJ-RAD00-00	扭簧 SPRING, TORSION 1	1	
19	2PJ-RA168-00	六角头螺栓 BOLT, HEX. M6X35	1	

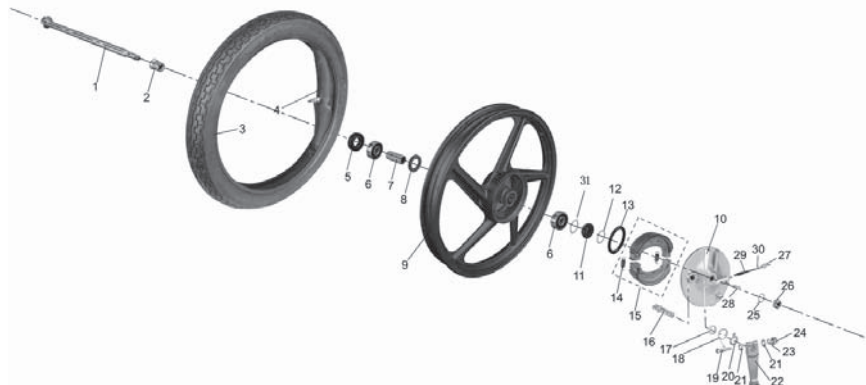

图 29 前压铸轮

FRONT WHEEL FOR CAST WHEEL

参照 号码	部品番号	中文名称 英文名称	状态	备注
			2PJ4	
20	2PJ-F533A-10	指示片 PLATE, INDICATOR	1	
21	2PJ-RA418-00	垫圈 WASHER 6	2	
22	2PJ-F5155-10	前制动臂 LEVER, CAMSHAFT 1	1	
23	2PJ-RA419-00	垫圈 WASHER 6	1	
24	2PJ-RA328-00	六角螺母 NUT, HEX. M6	1	
25	2PJ-F2243-00	平垫圈 WASHER, 1	1	
26	2PJ-RA337-00	锁紧螺母 NUT, U FLG. M10	1	
27	2PJ-RAY25-00	油封 SEAL, OIL 8	1	
28	2PJ-RA232-00	十字槽螺钉 SCREW M5X16	1	
29	2PJ-F5138-10	速度表齿轮 GEAR, METER	1	
30	2PJ-RA430-00	小垫圈 WASHER 5	1	
31	2PJ-F5149-00	速度表传动卡 CLUTCH, METER	1	

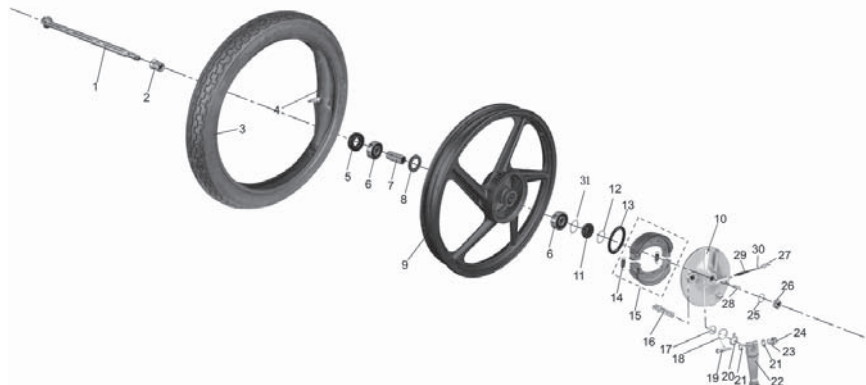

图 30 后压铸轮

REAR WHEEL FOR CAST WHEEL

参照 号码	部品番号	中文名称 英文名称	状态	备注
			2PJ4	
1	2PJ-RA339-00	锁紧螺母 NUT, U.FLG. M14	1	
2	2PJ-F5388-00	链条调节器组合 PULLER, CHAIN 1	2	
3	2PJ-RA228-00	螺栓 SCREW M8X45	2	
4	2PJ-RA331-00	六角螺母 NUT, HEX. M8	2	
5	2PJ-F5377-00	后轮轴右衬套 COLLAR, SHAFT	1	
6	2PJ-RA328-00	六角螺母 NUT, HEX. M6	1	
7	2PJ-RA419-00	垫圈 WASHER 6	1	
8	2PJ-RA418-00	垫圈 WASHER 6	2	
9	2PJ-F5355-00	后制动臂 LEVER, CAMSHAFT 1	1	
10	2PJ-RA155-00	六角头螺栓 BOLT, HEX. M6X35	1	
11	2PJ-F533A-00	指示片 PLATE, INDICATOR	1	
12	2PJ-RAY14-00	密封垫 GSKT., 1	1	
13	2PJ-RAY02-00	开口销 PIN, 2	1	
14	2PJ-RA331-00	六角螺母 NUT, HEX. M8	1	
15	2PJ-RA424-00	弹簧垫圈 WASHER 8	1	
16	2PJ-F5321-00	后制动盖 PLATE, BRAKE SHOE	1	
17	2PJ-F5373-00	螺栓 BOLT, TENSION BAR	1	
18	2PJ-F5351-00	凸轮轴 CAM, SHAFT 1	1	
19	2PJ-WF530-00	左右蹄块组合 BRAKE SHOE ASSY.	1	
20	2PJ-RAD01-00	拉簧 2 SPRING, TENSION 1	1	

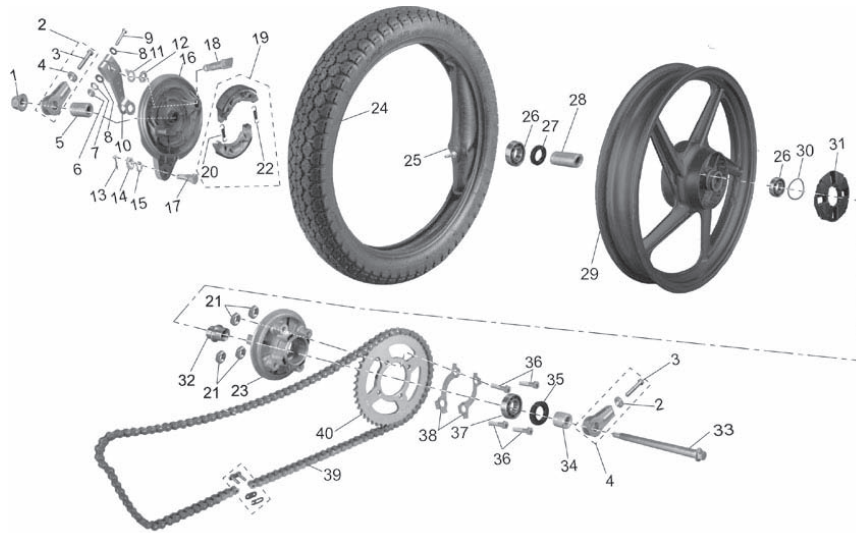

图 30 后压铸轮

REAR WHEEL FOR CAST WHEEL

参照 号码	部品番号	中文名称 英文名称	状态	备注
			2PJ4	
21	2PJ-RA330-00	六角薄螺母 NUT, HEX. M8	4	
22	2PJ-RAD03-00	拉簧 1 SPRING, TENSION 2	1	
23	2PJ-F5366-00	轮毂联轴器 CLUTCH, HUB	1	
24	2PJ-F53P3-00	后轮外胎 TIRE	1	
25	2PJ-RAY21-00	后轮内胎 TUBE	1	
26	2PJ-RAY01-00	滚动轴承 BEARING, 1	1	
27	2PJ-F5315-00	支承圈 FLG., SPACER1	1	
28	2PJ-F5317-10	衬管 SPACER, BEARING	1	
29	2PJ-F5338-00	后轮毂组合 WHEEL, CAST	1	
30	2PJ-RAF02-00	O 型圈 O-RING, 3	1	
31	2PJ-F5364-00	减震垫 DAMPER	4	
32	2PJ-F5387-00	链轮轴 SHAFT, SPROCKET	1	
33	2PJ-F5381-00	后轮轴 AXLE, WHEEL RR.	1	
34	2PJ-F5386-00	后轮轴左衬套 COLLAR, SPROCKET SHAFT	1	
35	2PJ-RAY20-00	油封 SEAL, OIL 5	1	
36	2PJ-RA160-00	六角头螺栓 BOLT, HEX. M8X35	1	
37	2PJ-RAG01-00	滚动轴承 BRG., 1	1	
38	2PJ-F5412-00	止动垫片 WASHER, LOCK	1	
39	2PJ-F53C0-00	链条 CHAIN ASSY.	1	
40	2PJ-F5445-00	链轮 SPROCKET, RR. WHEEL	1	

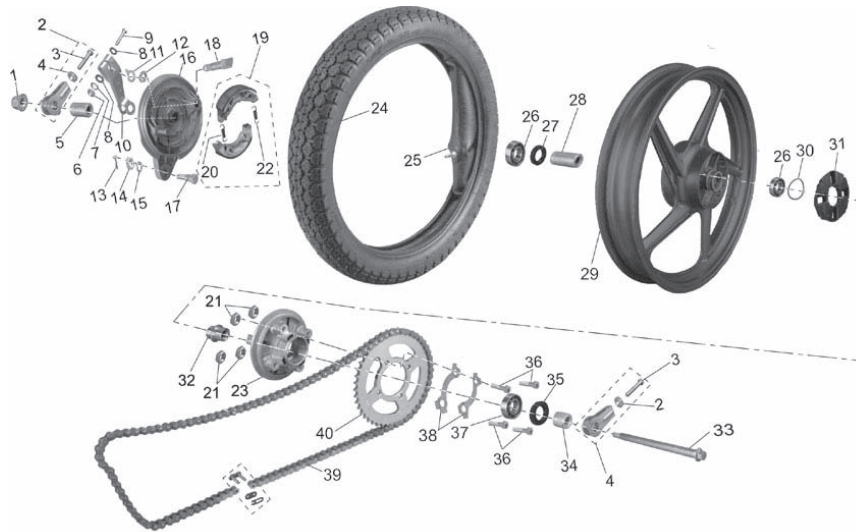

图 31 仪表

METER

参照 号码	部品番号	中文名称 英文名称	状态	备注
			2PJ4	
1	2PJ-H3500-00	仪表组合 METER ASSY.	1	
2	2PJ-HA251-00	车速表 SPEEDMETER	1	
3	2PJ-HA252-00	转速表 TACHOMETER	1	
4	2PJ-HA253-00	燃油表 FUEL METER	1	
5	2PJ-H353G-00	上罩 COVER UPPER	1	
6	2PJ-H350E-00	支撑架 SUPPORT	1	
7	2PJ-H3543-00	减震垫 PAD	4	
8	2PJ-H3509-00	线束 WIRE	1	
9	2PJ-H3517-00	照明灯泡 BULB, METER 1	4	
10	2PJ-H3518-00	指示灯泡 BULB, METER 2	4	
11	2PJ-H353H-00	仪表下罩 COVER BOTTOM	1	
12	2PJ-H354P-00	盖型螺母 NUT	4	
13	2PJ-H3524-00	垫圈 WASHER	4	
14	2PJ-H353S-00	旋钮安装螺钉 SCREW	1	
15	2PJ-H357H-00	回零旋钮 SWITCH	1	
16	2PJ-H3645-00	油表螺钉 SCREW	3	
17	2PJ-H362Y-00	自攻螺钉 SCREW	2	
18	2PJ-H3549-00	自攻螺钉 SCREW	1	
19	2PJ-H5213-00	燃油表照明灯泡 BULB	1	
20	2PJ-RA223-00	六角法兰面螺栓 SCREW M6X16	2	

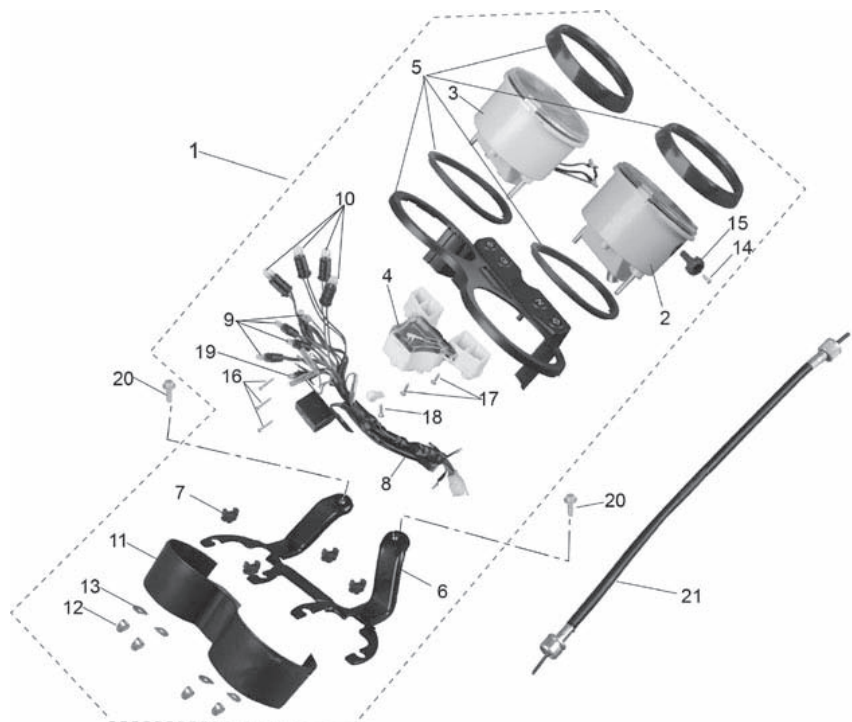

图 31 仪表

METER

参照 号码	部品番号	中文名称 英文名称	状态	备注
			2PJ4	
21	2PJ-H3550-00	里程计软轴 SPEEDO. CABLE ASSY.	1	

图 32 转向灯

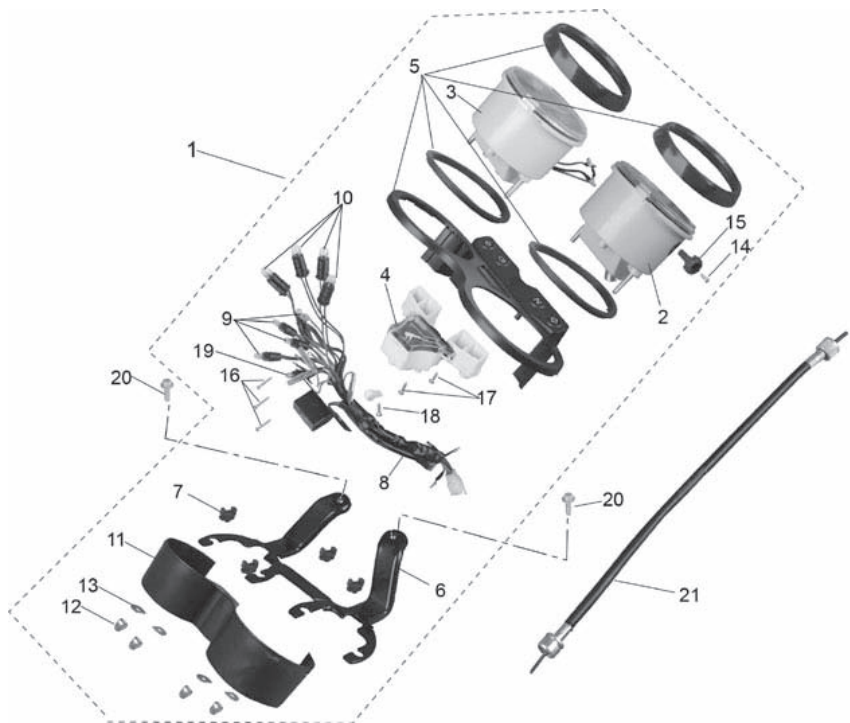
FLASHER LIGHT

参照 号码	部品番号	中文名称 英文名称	状态	备注
			2PJ4	
1	2PJ-H3340-00	后右转向灯 RR. FLASHER LIGHT ASSY., 2	1	
2	2PJ-RA219-00	螺钉 SCREW M6X10	2	
3	2PJ-H3311-00	灯泡 R10W 12V10W BULB, FLASHER	4	
4	2PJ-H3359-00	后转向灯限位垫圈 WASHER, SPECIAL	2	
5	2PJ-RA334-00	螺母 NUT, FLG. M10	4	
6	2PJ-H3330-00	后左转向灯 RR. FLASHER LIGHT ASSY., 1	1	
7	2PJ-H3321-00	缓冲垫 DAMPER, FLASHER 1	2	
8	2PJ-H3310-00	前左转向灯 FR. FLASHER LIGHT ASSY., 2	1	
9	2PJ-RA220-00	螺钉 SCREW M6X12	2	
10	2PJ-H3348-00	平垫圈 WASHER	2	
11	2PJ-H3320-00	前右转向灯 FR. FLASHER LIGHT ASSY., 1	1	

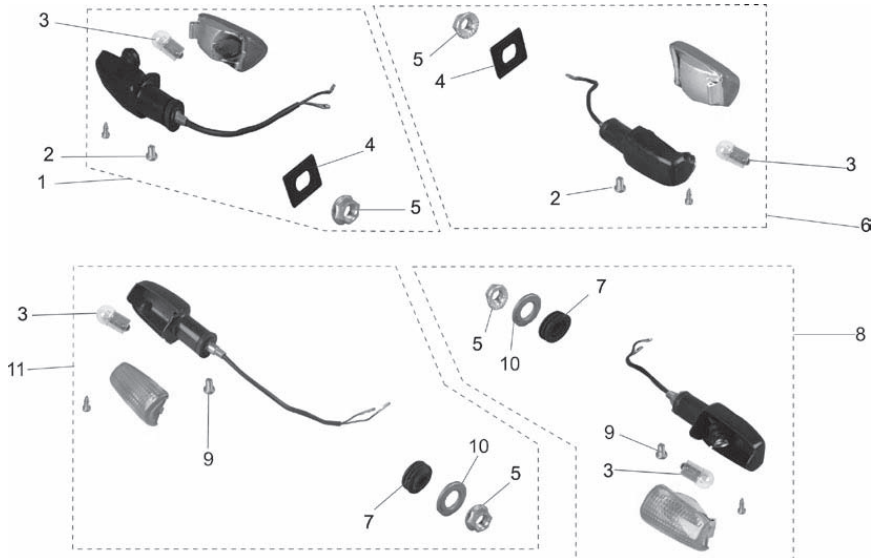



图 33 前照灯

HEADLIGHT

参照 号码	部品番号	中文名称 英文名称	状态	备注
			2PJ4	
1	2PJ-H4300-00	前照灯 HEAD LIGHT ASSY.	1	
2	2PJ-H4163-00	衬套 DAMPER, HEAD LIGHT A	1	
3	2PJ-H4145-00	套管 COLLAR	1	
4	2PJ-RA159-00	六角法兰面螺栓 BOLT, FLG. M8X30	2	
5	2PJ-H4164-00	衬套 DAMPER, HEAD LIGHT B	2	
6	2PJ-H4130-00	灯体总成 BODY ASSY.	1	
7	2PJ-H4127-00	平垫圈 $\phi 8$ WASHER, SPECIAL	2	
8	2PJ-RA333-00	安装垫圈 NUT, CAP M8	2	
9	2PJ-H4359-00	前灯线组合 CORD, HEAD LIGHT	1	
10	2PJ-H4312-00	位置灯灯座组合 CORD ASSY.	1	
11	2PJ-H4347-00	灯泡 12V5W W2.1x9.5d BULB, PILOT LIGHT	1	
12	2PJ-H4526-00	螺钉 SCREW	2	
13	2PJ-H4315-00	圆形边框 RIM, HEAD LAMP	1	
14	2PJ-H410A-00	前灯组件总成 HEAD LIGHT UNIT COMP.	1	
15	2PJ-H4363-00	弹簧卡 SPRG. LAMP SET	3	
16	2PJ-H4314-00	灯泡 12V35/35W BULB, HEAD LIGHT	1	
17	2PJ-H4375-00	卡簧 BULB, SETTING	1	

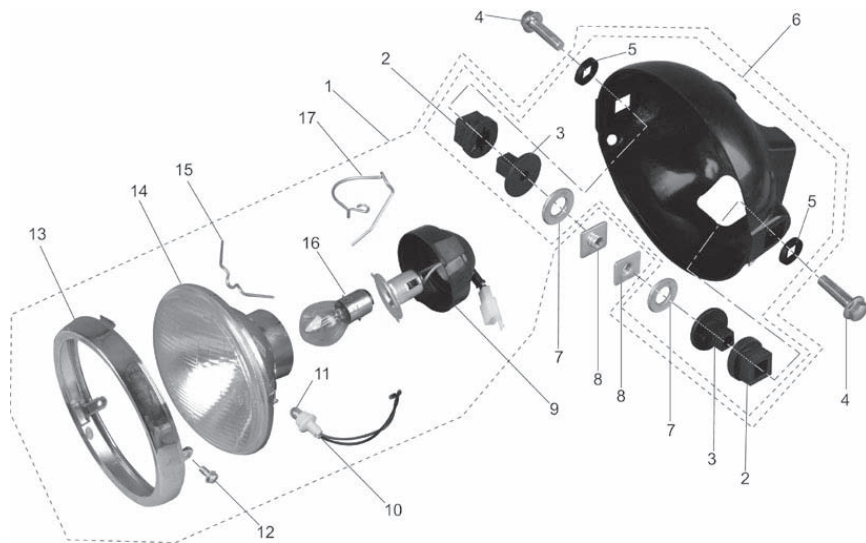

图 34 尾灯

TAILLIGHT

参照 号码	部品番号	中文名称 英文名称	状态	备注
			2PJ4	
1	2PJ-H4710-00	尾灯组合 TAIL LIGHT UNIT ASSY.	1	
2	2PJ-H4721-00	尾灯透射镜 LENS, TAIL	1	
3	2PJ-H4724-00	螺钉 SCREW, LENS FITTING	2	
4	2PJ-H4714-00	灯泡 12VP21/5W BULB, TAIL LIGHT	1	
5	2PJ-H4720-00	尾灯安装板 BASE ASSY.	1	
6	2PJ-H4718-00	尾灯胶套 GROMMET, TAIL LAMP	2	
7	2PJ-RA712-00	尾灯衬套 COLLAR	2	
8	2PJ-RA417-00	大垫圈 WASHER 6	2	
9	2PJ-RA326-00	六角螺母 NUT, HEX. M6	2	
10	2PJ-H4753-00	尾灯减震垫 DAMPER	2	

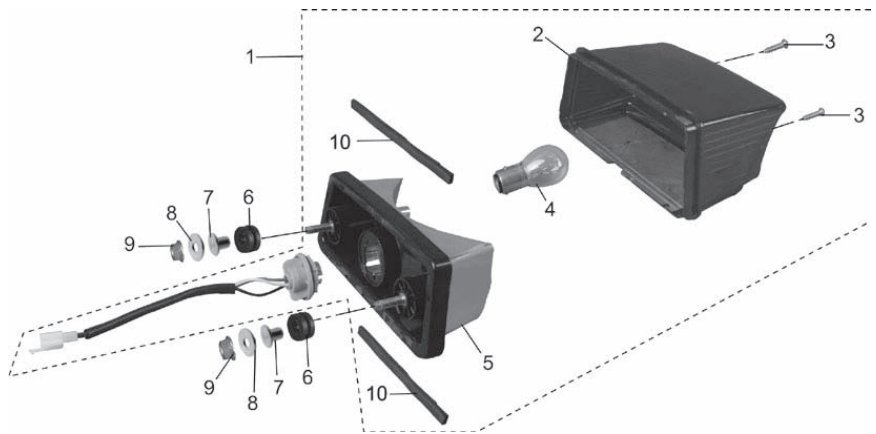

图 35-1 电器 1

ELECTRICAL 1

参照 号码	部品番号	中文名称 英文名称	状态	备注
			2PJ4	
1	2PJ-H1960-10	整流调节器 RECTIFIER REGULATOR ASSY.	1	
2	2PJ-RA224-00	螺钉平垫圈组合 SCREW M6X20	2	
3	2PJ-H2021-00	三锁总成 Three lock assembly	1	
4	2PJ-RA148-00	内六角圆柱头螺钉 BOLT, HEX. SOCKET M6X20	2	
5	2PJ-H2501-00	总开关锁 MAIN SW. STRG. LOCK ASSY.	1	
6	2PJ-H2151-00	保险片 FUSE	1	
7	2PJ-H1940-00	启动继电器 STARTER RELAY ASSY.	1	
8	2PJ-RA418-00	平垫圈 WASHER 6	2	
9	2PJ-RA419-00	垫圈 WASHER 6	2	
10	2PJ-RA328-00	六角螺母 NUT, HEX. M6	2	
11	2PJ-H2530-00	后制动开关 STOP SWITCH ASSY.	1	
12	2PJ-H2115-00	正极导线 WIRE, PLUS LEAD 1	1	
13	2PJ-H2353-00	溢流管 HOSE	1	
14	2PJ-H2100-00	蓄电池组件 BTRY. ASSY., 2	1	
15	2PJ-H2131-00	蓄电池撞带 BAND, BATTERY	1	
16	5VL-H2116-00	负极导线 WIRE, MINUS LEAD 2	1	

图 36-2 电器 2

ELECTRICAL 2

参照 号码	部品番号	中文名称 英文名称	状态	备注
			2PJ4	
1	2PJ-H5540-00	可控硅触发器 CDI. UNIT ASSY.	1	
2	2PJ-RA170-00	六角法兰面螺栓 BOLT, FLG. M6X10	1	
3	2PJ-H3371-00	喇叭 HORN	1	
4	2PJ-RA231-00	十字槽小盘头螺钉 SCREW M6X16	2	
5	2PJ-H2310-00	点火线圈组合 IGN. COIL ASSY.	1	
6	2PJ-H2590-00	电缆 WIRE HARNESS ASSY.	1	
7	2PJ-H2591-00	电缆箍带 1 BAND	4	
8	2PJ-H2592-00	电缆箍带 BAND	1	
9	2PJ-H3350-00	闪光继电器组件 FLASHER RELAY ASSY.	1	



零件号码索引
PARTS NO INDEX CHART

部品番号	图号	部品番号	图号	部品番号	图号	部品番号	图号	部品番号	图号	部品番号	图号
13R-H2540-00	9-10	2PJ-E4191-00	13-15	2PJ-F1611-00	19-17	2PJ-F3191-00	24-14	2PJ-F4522-00	27-19	2PJ-F53C0-00	30-39
1BK-E1181-00	1-15	2PJ-E4196-00	13-17	2PJ-F1621-00	19-10	2PJ-F3192-00	24-15	2PJ-F4605-00	27-5	2PJ-F53P3-00	30-24
1BK-E1310-00	1-18	2PJ-E4216-00	13-18	2PJ-F1637-00	19-9	2PJ-F331X-00	23-20	2PJ-F4682-00	18-4	2PJ-F5412-00	30-38
1BK-E2111-00	2-1	2PJ-E4231-00	13-6	2PJ-F1685-00	19-11	2PJ-F3346-00	23-19	2PJ-F471K-00-P0	19-3	2PJ-F5445-00	30-40
1BK-E2119-00	2-3	2PJ-E4261-00	13-5	2PJ-F1708-00	20-4	2PJ-F334G-10	23-9	2PJ-F471K-00-P1	19-3	2PJ-F6111-00	21-5
1BK-E2121-00	2-2	2PJ-E4410-00	12-1	2PJ-F1711-00-P0	20-3	2PJ-F3389-00	23-21	2PJ-F471K-00-P2	19-3	2PJ-F6240-00	21-11
1BK-E2171-00	3-1	2PJ-E4411-00	12-7	2PJ-F1711-00-P1	20-3	2PJ-F3395-10	23-26	2PJ-F472K-00-P0	19-2	2PJ-F6241-00	21-6
1BK-E5580-00	15-17	2PJ-E4412-00	12-3	2PJ-F1711-00-P2	20-3	2PJ-F3411-00	23-14	2PJ-F472K-00-P1	19-2	2PJ-F6280-00	21-13
1BK-E6111-00	7-1	2PJ-E443E-00	12-8	2PJ-F1721-00-P0	20-1	2PJ-F3412-00	23-16	2PJ-F472K-00-P2	19-2	2PJ-F6290-00	21-12
1BK-E6150-00	7-6	2PJ-E4450-00	12-5	2PJ-F1721-00-P1	20-1	2PJ-F3413-00	23-18	2PJ-F4730-00	28-1	2PJ-F6311-00	21-1
1BK-E6154-00	7-7	2PJ-E4452-00	12-6	2PJ-F1721-00-P2	20-1	2PJ-F3414-00	23-17	2PJ-F4741-00	28-2	2PJ-F632G-00	21-2
1BK-E6300-10	7-5	2PJ-E4453-00	12-10	2PJ-F1773-00	19-4	2PJ-F3416-00	23-13	2PJ-F4785-00	19-7	2PJ-F6331-00	21-9
1BK-E6321-10	7-9	2PJ-E4462-00	12-4	2PJ-F1773-00	20-5	2PJ-F3418-00	23-10	2PJ-F4796-00	19-8	2PJ-F6335-00	21-10
1BK-E6324-10	7-10	2PJ-E4589-00	13-10	2PJ-F1778-00	20-2	2PJ-F341E-00	23-15	2PJ-F4840-00	28-5	2PJ-F6341-10	21-3
1BK-E6333-00	7-12	2PJ-E4613-00	14-8	2PJ-F177G-00	17-9	2PJ-F3435-00	23-4	2PJ-F510S-00	29-3	2PJ-F6343-00	22-5
1BK-E6337-00	7-13	2PJ-E4628-00	14-2	2PJ-F2110-00	25-17	2PJ-F3441-00	23-5	2PJ-F510T-00	29-4	2PJ-F6345-00	22-7
1BK-E6351-10	7-11	2PJ-E4710-00	14-1	2PJ-F2123-00	25-15	2PJ-F3444-00	23-12	2PJ-F5115-00	29-8	2PJ-F6348-00	21-4
1BK-E6371-10	7-8	2PJ-E4737-00	14-3	2PJ-F2124-00	25-14	2PJ-F3453-00	23-11	2PJ-F5117-10	29-7	2PJ-F6353-00	21-8
1BK-E8185-00	9-2	2PJ-E4758-00	14-6	2PJ-F2128-00	25-12	2PJ-F3454-00	23-8	2PJ-F5121-10	29-10	2PJ-F6353-00	26-28
1JD-E8542-00	9-13	2PJ-E4803-00	18-15	2PJ-F2141-00	25-11	2PJ-F4110-00-P0	27-9	2PJ-F5135-10	29-11	2PJ-F6372-00	21-14
1SF-E2113-00	2-5	2PJ-E4815-00	18-16	2PJ-F2151-00	25-13	2PJ-F4110-00-P1	27-9	2PJ-F5138-10	29-29	2PJ-F7111-00	26-23
1SF-E5411-00	6-17	2PJ-E4871-00	18-13	2PJ-F2184-00	25-16	2PJ-F4110-00-P2	27-9	2PJ-F5149-00	29-11	2PJ-F7112-00	26-2
1SF-E5421-20	6-1	2PJ-E4881-00	18-18	2PJ-F2210-00	25-1	2PJ-F4135-00	18-24	2PJ-F5155-10	29-22	2PJ-F7115-00	26-21
1SF-E8540-00	9-1	2PJ-E4882-00	18-17	2PJ-F2243-00	25-2	2PJ-F4170-00	18-10	2PJ-F5168-00	29-9	2PJ-F7116-00	26-22
1SF-H1410-20	15-18	2PJ-E4883-00	18-14	2PJ-F2243-00	29-25	2PJ-F4176-00	27-10	2PJ-F5181-00	29-1	2PJ-F7119-00	26-20
1SF-H1450-20	15-13	2PJ-E4901-00	13-1	2PJ-F2311-00	25-5	2PJ-F4180-00	18-6	2PJ-F5183-10	29-2	2PJ-F7211-00	26-17
1SF-W1510-00	5-1	2PJ-E490J-00	13-9	2PJ-F3102-00	23-24	2PJ-F4181-00	17-4	2PJ-F5315-00	30-27	2PJ-F7216-00	26-19
22F-11134-10	1-3	2PJ-E4985-00	13-12	2PJ-F3102-10	24-1	2PJ-F4182-00	17-5	2PJ-F5317-10	30-28	2PJ-F7231-00	26-24
2D0-E3411-00	11-9	2PJ-E5418-00	6-9	2PJ-F3103-10	23-23	2PJ-F4183-00	27-12	2PJ-F5321-00	30-16	2PJ-F7236-00	26-26
2D0-E8511-00	9-5	2PJ-E5618-00	16-11	2PJ-F3103-10	24-16	2PJ-F4186-00	27-11	2PJ-F5338-00	30-29	2PJ-F7311-00	26-16
2D0-E8512-00	9-6	2PJ-E5620-00	16-10	2PJ-F3106-10	24-2	2PJ-F4311-00	27-16	2PJ-F533A-00	30-11	2PJ-F7316-00	26-15
2D0-E8513-00	9-7	2PJ-E7451-00	8-26	2PJ-F3107-10	24-17	2PJ-F4312-00	18-7	2PJ-F533A-10	29-20	2PJ-F7317-00	26-14
2PJ-E1166-00	5-4	2PJ-E7456-00	8-27	2PJ-F3110-00	24-13	2PJ-F4313-00	18-19	2PJ-F5351-00	30-18	2PJ-F7318-00	26-13
2PJ-E3566-00	13-21	2PJ-E8110-00	10-9	2PJ-F3111-00	24-11	2PJ-F4314-00	18-2	2PJ-F5351-10	29-16	2PJ-F7411-00	26-12
2PJ-E3575-00	12-9	2PJ-E8113-00	10-10	2PJ-F3118-00	24-9	2PJ-F4315-00	18-3	2PJ-F5355-00	30-9	2PJ-F7413-00	26-11
2PJ-E3586-00	13-22	2PJ-F1110-00	17-3	2PJ-F3141-00	24-8	2PJ-F4316-00	18-5	2PJ-F5364-00	30-31	2PJ-F7431-00	26-3
2PJ-E4103-00	13-3	2PJ-F1110-W0	17-3	2PJ-F3144-00	24-4	2PJ-F4317-00	18-23	2PJ-F5366-00	30-23	2PJ-F7433-00	26-4
2PJ-E4105-00	13-2	2PJ-F1316-00	17-19	2PJ-F3145-00	24-3	2PJ-F4318-00	27-1	2PJ-F5371-00	25-7	2PJ-F7438-00	26-6
2PJ-E4112-00	13-8	2PJ-F1317-00	17-16	2PJ-F3146-00	24-10	2PJ-F4398-00	18-9	2PJ-F5373-00	30-17	2PJ-F7445-00	26-5
2PJ-E4139-00	13-16	2PJ-F1318-00	17-15	2PJ-F3152-00	24-6	2PJ-F4399-00	17-2	2PJ-F5377-00	30-5	2PJ-F7452-00	26-1
2PJ-E4141-00	13-4	2PJ-F1511-00-P0	19-20	2PJ-F3157-00	24-7	2PJ-F4444-00	17-1	2PJ-F5378-00	25-6	2PJ-F7462-00	26-7
2PJ-E4142-00	13-7	2PJ-F1511-00-P1	19-20	2PJ-F3165-00	23-7	2PJ-F4477-00	17-21	2PJ-F5381-00	30-33	2PJ-F8100-00	17-7
2PJ-E4147-00	13-14	2PJ-F1511-00-P2	19-20	2PJ-F3170-00	24-5	2PJ-F4500-00	27-13	2PJ-F5386-00	30-34	2PJ-F811G-00	17-8
2PJ-E4150-00	13-11	2PJ-F1518-00	19-19	2PJ-F3174-00	23-1	2PJ-F4512-00	27-18	2PJ-F5387-00	30-32	2PJ-H1800-00	15-1
2PJ-E4186-00	13-13	2PJ-F1531-00	19-21	2PJ-F317J-00	23-2	2PJ-F4522-00	27-17	2PJ-F5388-00	30-2	2PJ-H1801-00	15-2

零件号码索引
PARTS NO INDEX CHART

部品番号	图号	部品番号	图号	部品番号	图号	部品番号	图号	部品番号	图号	部品番号	图号
2PJ-H182A-00	15-5	2PJ-H3550-10	31-21	2PJ-RA139-00	8-28	2PJ-RA226-00	10-11	2PJ-RA430-00	29-30	5VL-E1422-00	4-6
2PJ-H182K-00	15-6	2PJ-H357H-00	31-15	2PJ-RA140-00	18-8	2PJ-RA227-00	20-7	2PJ-RA431-00	20-6	5VL-E1454-00	4-8
2PJ-H182L-00	15-4	2PJ-H362Y-00	31-17	2PJ-RA141-00	19-16	2PJ-RA228-00	30-3	2PJ-RA712-00	34-7	5VL-E1631-00	4-11
2PJ-H182M-00	15-3	2PJ-H3645-00	31-16	2PJ-RA142-00	27-2	2PJ-RA229-00	19-6	2PJ-RAC00-00	18-21	5VL-E1633-00	4-12
2PJ-H183G-00	15-7	2PJ-H3912-00	22-13	2PJ-RA143-00	28-3	2PJ-RA230-00	23-25	2PJ-RAC00-00	12-11	5VL-E1651-00	4-5
2PJ-H1940-00	35-1-7	2PJ-H3915-00	22-15	2PJ-RA143-00	17-6	2PJ-RA231-00	36-1-4	2PJ-RAC05-00	27-15	5VL-E1681-00	4-3
2PJ-H1960-10	35-1-1	2PJ-H3922-00	22-20	2PJ-RA143-00	19-18	2PJ-RA232-00	29-28	2PJ-RAC07-00	18-22	5VL-E2116-01	2-4
2PJ-H2021-00	35-1-3	2PJ-H3941-00	22-14	2PJ-RA144-00	18-12	2PJ-RA325-00	19-15	2PJ-RAC07-00	5-5	5VL-E2117-01	2-7
2PJ-H2100-00	35-1-14	2PJ-H3945-00	22-17	2PJ-RA146-00	23-27	2PJ-RA326-00	34-9	2PJ-RAC08-00	18-20	5VL-E2118-00	2-6
2PJ-H2115-00	35-1-12	2PJ-H3973-00	22-12	2PJ-RA147-00	19-1	2PJ-RA327-00	13-19	2PJ-RAC08-00	18-1	5VL-E2151-00	2-8
2PJ-H2131-00	35-1-15	2PJ-H3975-00	22-1	2PJ-RA148-00	35-1-4	2PJ-RA328-00	29-24	2PJ-RAD00-00	29-18	5VL-E2156-00	2-10
2PJ-H2151-00	35-1-6	2PJ-H3980-00	22-6	2PJ-RA148-00	14-9	2PJ-RA328-00	30-6	2PJ-RAD01-00	30-20	5VL-E2176-00	3-6
2PJ-H2310-00	36-1-5	2PJ-H410A-00	33-14	2PJ-RA151-00	22-18	2PJ-RA328-00	35-1-10	2PJ-RAD03-00	30-22	5VL-E2210-01	3-14
2PJ-H2353-00	35-1-13	2PJ-H4127-00	33-7	2PJ-RA152-00	13-23	2PJ-RA329-00	22-16	2PJ-RAD04-00	29-14	5VL-E2213-10	3-15
2PJ-H2501-00	35-1-5	2PJ-H4130-00	33-6	2PJ-RA153-00	13-24	2PJ-RA330-00	30-21	2PJ-RAF00-00	13-20	5VL-E2231-00	3-10
2PJ-H2530-00	35-1-11	2PJ-H4145-00	33-3	2PJ-RA153-00	15-8	2PJ-RA331-00	30-14	2PJ-RAF02-00	30-30	5VL-E2241-00	3-11
2PJ-H2590-10	36-1-6	2PJ-H4163-00	33-2	2PJ-RA155-00	30-10	2PJ-RA331-00	30-4	2PJ-RAG01-00	30-37	5VL-E3300-01	11-1
2PJ-H2591-00	36-1-7	2PJ-H4164-00	33-5	2PJ-RA156-00	28-4	2PJ-RA331-00	25-9	2PJ-RAY00-00	21-7	5VL-E3324-00	11-10
2PJ-H2592-00	36-1-8	2PJ-H4300-00	33-1	2PJ-RA157-00	26-10	2PJ-RA332-00	17-12	2PJ-RAY00-00	26-27	5VL-E3325-00	11-2
2PJ-H2593-00	22-19	2PJ-H4312-00	33-10	2PJ-RA159-00	33-4	2PJ-RA333-00	33-8	2PJ-RAY01-00	29-6	5VL-E3451-00	11-11
2PJ-H2911-00	22-11	2PJ-H4314-00	33-16	2PJ-RA160-00	30-36	2PJ-RA334-00	32-5	2PJ-RAY01-00	30-26	5VL-E5191-00	6-18
2PJ-H2917-00	22-9	2PJ-H4315-00	33-13	2PJ-RA161-00	17-14	2PJ-RA335-00	17-20	2PJ-RAY02-00	25-10	5VL-E5362-00	6-5
2PJ-H2921-00	22-4	2PJ-H4347-00	33-11	2PJ-RA162-00	23-3	2PJ-RA336-00	25-3	2PJ-RAY02-00	26-29	5VL-E5441-01	5-11
2PJ-H3310-00	32-8	2PJ-H4359-00	33-9	2PJ-RA163-00	17-13	2PJ-RA337-00	29-26	2PJ-RAY02-00	30-13	5VL-E5451-10	6-16
2PJ-H3311-00	32-3	2PJ-H4363-00	33-15	2PJ-RA164-00	17-18	2PJ-RA338-00	25-18	2PJ-RAY07-00	26-18	5VL-E5461-10	6-8
2PJ-H3320-00	32-11	2PJ-H4375-00	33-17	2PJ-RA165-00	17-10	2PJ-RA339-00	30-1	2PJ-RAY08-00	26-9	5VL-E5512-00	15-10
2PJ-H3321-00	32-7	2PJ-H4526-00	33-12	2PJ-RA166-00	17-11	2PJ-RA340-00	19-5	2PJ-RAY14-00	30-12	5VL-E5517-00	15-15
2PJ-H3330-00	32-6	2PJ-H4710-00	34-1	2PJ-RA167-00	17-17	2PJ-RA417-00	34-8	2PJ-RAY17-00	29-17	5VL-E5521-00	15-9
2PJ-H3340-00	32-1	2PJ-H4714-00	34-4	2PJ-RA168-00	29-19	2PJ-RA418-00	30-8	2PJ-RAY20-00	30-35	5VL-E5532-00	15-11
2PJ-H3348-00	32-10	2PJ-H4718-00	34-6	2PJ-RA170-00	36-1-2	2PJ-RA418-00	29-21	2PJ-RAY21-00	30-25	5VL-E5598-00	3-12
2PJ-H3350-00	36-1-9	2PJ-H4720-00	34-5	2PJ-RA213-00	27-8	2PJ-RA418-00	35-1-8	2PJ-RAY23-00	29-5	5VL-E5651-00	16-7
2PJ-H3359-00	32-4	2PJ-H4721-00	34-2	2PJ-RA214-00	27-7	2PJ-RA418-00	26-25	2PJ-RAY24-00	29-13	5VL-E5660-01	16-1
2PJ-H3371-00	36-1-3	2PJ-H4724-00	34-3	2PJ-RA216-00	27-6	2PJ-RA419-00	29-23	2PJ-RAY25-00	29-27	5VL-E6164-10	7-17
2PJ-H3500-00	31-1	2PJ-H4753-00	34-10	2PJ-RA217-00	22-2	2PJ-RA419-00	30-7	2PJ-WF530-00	30-19	5VL-E6357-01	7-21
2PJ-H3509-00	31-8	2PJ-H5110-00	24-12	2PJ-RA218-00	22-3	2PJ-RA419-00	35-1-9	2PJ-WF530-10	29-15	5VL-E6381-02	7-22
2PJ-H350E-00	31-6	2PJ-H5130-00	19-12	2PJ-RA219-00	32-2	2PJ-RA420-00	22-10	2UJ-11133-10	1-2	5VL-E7121-00	8-3
2PJ-H3517-00	31-9	2PJ-H5213-00	31-19	2PJ-RA220-00	32-9	2PJ-RA421-00	19-13	4FP-E1167-00	5-3	5VL-E7131-00	8-4
2PJ-H3518-00	31-10	2PJ-H5540-00	36-1-1	2PJ-RA221-00	14-7	2PJ-RA422-00	19-14	4FP-E5641-00	16-2	5VL-E7141-00	8-5
2PJ-H3524-00	31-13	2PJ-H5752-00	27-3	2PJ-RA222-00	25-4	2PJ-RA424-00	25-8	4FP-E5666-00	16-6	5VL-E7151-00	8-2
2PJ-H353G-00	31-5	2PJ-H5753-00	27-4	2PJ-RA223-00	31-20	2PJ-RA424-00	30-15	4FP-E8177-00	10-3	5VL-E7211-00	8-19
2PJ-H353H-00	31-11	2PJ-HA251-00	31-2	2PJ-RA223-00	6-10	2PJ-RA425-00	26-8	5VL-E1111-11	1-1	5VL-E7221-00	8-14
2PJ-H353S-00	31-14	2PJ-HA252-00	31-3	2PJ-RA224-00	27-14	2PJ-RA426-00	22-8	5VL-E1111F-00	3-4	5VL-E7231-00	8-15
2PJ-H3543-00	31-7	2PJ-HA253-00	31-4	2PJ-RA224-00	18-11	2PJ-RA427-00	14-5	5VL-E1185-10	1-7	5VL-E7241-00	8-18
2PJ-H3549-00	31-18	2PJ-RA133-00	23-6	2PJ-RA224-00	35-1-2	2PJ-RA428-00	14-4	5VL-E1186-00	1-10	5VL-E7251-00	8-13
2PJ-H354P-00	31-12	2PJ-RA135-00	23-22	2PJ-RA224-00	12-2	2PJ-RA429-00	29-12	5VL-E1351-10	1-19	5VL-E7462-00	8-12

零件号码索引
PARTS NO INDEX CHART

部品番号	图号	部品番号	图号	部品番号	图号
5VL-E7411-00	8-1	90430-06817	3-17	95022-06030	5-7
5VL-E7471-00	8-10	90430-12227	11-8	95022-06035	6-15
5VL-E8101-12	10-7	90462-16801	5-6	95022-06035	6-2
5VL-E8140-00	10-1	90468-26813	16-3	95022-06045	5-8
5VL-E8337-00	10-2	90501-06805	9-14	95022-06045	6-4
5VL-E8531-00	9-8	90508-16800	7-23	95022-06050	6-13
5VL-E8535-00	9-9	90508-26836	16-5	95022-06055	5-9
5VL-H2116-00	35-1-16	90508-32801	10-5	95302-06600	7-16
5VL-W1140-20	4-1	91312-06012	3-5	95802-06020	3-13
5VL-W1141-00	4-2	91312-06014	15-19	98512-06010	6-19
5VL-W1161-00	4-14	91312-06025	15-20	98512-06012	15-12
5VL-Y1153-00	4-7	91312-06090	1-17	98512-06012	8-11
5VL-Y1215-00	2-9	91312-08016	15-16	99002-05600	11-3
5VL-Y1635-10	7-14	92902-06200	7-15	99002-10600	10-6
90101-08820	3-8	93101-10800	6-7	99009-15400	16-9
90105-08724	1-12	93101-12803	10-4	99009-15400	8-21
90151-06818	9-4	93102-12812	7-24	99009-15400	8-30
90153-06803	1-5	93102-20812	8-24	99009-20500	7-25
90154-05802	9-11	93109-20806	16-13	99530-10114	1-16
90155-06800	11-6	93210-11809	4-9	99530-10114	5-10
90170-12060	7-19	93210-14817	6-12	99530-10114	5-2
90179-12813	7-4	93210-19808	6-6	99530-10114	6-14
90179-12813	16-12	93210-23801	9-12	99530-10114	6-3
90179-12863	4-18	93210-44812	1-11		
90201-07641	11-4	93210-79802	1-8		
90201-08326	3-7	93306-002YM	3-2		
90201-088C3	1-13	93306-003YS	3-3		
90201-122H1	4-17	93306-201YD	8-8		
90201-122H1	7-3	93306-202XN	4-15		
90201-152H7	16-8	93306-203YT	8-9		
90201-15700	8-20	93306-204XD	8-23		
90201-20266	8-16	93306-205YP	4-10		
90201-20266	8-6	93306-252XH	8-25		
90201-20272	8-22	93310-629Y3	4-4		
90201-208D5	16-4	93410-20809	8-17		
90201-258D7	15-14	93410-20809	8-7		
90208-07052	11-5	93440-10109	1-4		
90215-12211	7-18	93450-16812	4-13		
90280-03017	4-16	93503-16824	7-20		
90282-05001	7-2	93604-10837	9-3		
90340-12097	11-7	93608-30839	10-8		
90340-14810	6-11	94568-C1088	3-9		
90387-15803	8-29	94700-00869	1-14		
90387-167L5	3-18	95022-06016	3-16		
90430-06817	1-6	95022-06020	1-9		

雅马哈纯正用品大集结



① 纯色头盔(全盔)

- BL
- RD
- BK



④ 纯色头盔(半盔)

- BL
- RD
- BK



② 锋利头盔(全盔)

- BL
- RD
- BK
- WH



⑤ 锋利头盔(半盔)

- BL
- RD
- BK
- WH



③ 鹰眼头盔(全盔)

- BL
- RD
- BK



⑥ 飞行盔(半盔)

- BL
- BR
- BK
- WH

编号①: Q01-00001-尺寸代码-颜色代码

编号②: Q01-00003-尺寸代码-颜色代码

编号③: Q01-NS001-尺寸代码-颜色代码

编号④: Q01-00002-尺寸代码-颜色代码

编号⑤: Q01-00004-尺寸代码-颜色代码

编号⑥: Q01-00006-尺寸代码-颜色代码

尺寸	M	L	XL	XXL
尺寸代码	0M	0L	0X	2X



YAMAHA尾箱

编号: Q41-20000-33-BK

YAMAHA尾箱靠背

编号: Q41-20000-33-CC

雅马哈纯正机油大集结



纯正机油

品质保证! 动力之源!

请经销YAMALUBE纯正
机油!



90793-AC421-T1
90793-AC421-G1
SAE 10W-40 (1L)
高等级/通用



90793-AC432-00
SAE 10W-30 (1L)
通用机油



90793-AC432-T1
SAE 10W-30 (1L)
通用机油



90793-AC423-T2
90793-AC423-G2
SAE 20W-40 (1L)
通用机油



90793-AC427-T1
90793-AC427-G1
SAE 10W-40 (0.8L)
弯梁车专用



90793-AC426-T1
SAE 5W-30 (1L)
冬季专用/通用



90793-AC434-00
SAE 10W-30 (0.8L)
弯梁车专用



90793-AC404
GEAR (0.13L)
齿轮油
踏板车专用



90793-AC423-P1
SAE 20W-40 (1L)
通用机油

友情提示: 磨合期后, 建议每1500KM更换一次机油(可根据实际使用状况减少里程数)。并清洗机油滤网。