

翻印必究



上海雅马哈建设摩托车销售有限公司

<http://www.yamaha-motor.com.cn/>

第二版 2015年06月



SHANGHAI YAMAHA JIANSHE MOTOR MARKETING CO., LTD.

# 零件目录

YS150-5 (2SB1)

2SB-F8198-1P-M1

1P2SB-415M1



YS150-5 (2SB1)





2SB1 (碟刹/压铸轮)

代号	颜色
0903	梦幻黑



代号	颜色
0740	飞炫紫



代号	颜色
1218	雅致红



代号	颜色
0390	玉石白





# 前言

本零件目录记载着封面页所示型号所使用的零件。当您订购更换零件时，请参阅本零件目录并正确指示零件号码和零件名称。

6. 在参照号码前的星号 (\*) 表示其为在第一版后更改的项目。

1. 零件目录发行后有变更或附加零件时，将会以雅马哈零件信息通知大家。  
建议您应按照雅马哈零件信息修改本零件目录。

2. 省略记号  
本文中所记载的省略记号的意思如下。

“UR” 需要指定的零件号码。

“UN” 需要数。

“AP” 选购品

“LM” 当地制造（必需于当地订购的零件）

“F#” 车架号（适用的机器号）

“O/S” 超过尺寸

3. 组件中部件的数量

- 组件的销售零件，如下所示，在零件名称的前面加上 (.) 的记号来表示。
- 每个部件右侧的数字表示各组件单体内该部件的数量。

零件号码	零件名称	数量	备注
2F5 - 83310 - 60	前闪光灯组合	2	
115 - 83311 - 60	. 灯泡 (6V - 18W)	1	

4. 适用的图形颜色表示在“备注”中，如下所示。

零件号码	零件名称	数量	备注
2N4 - 24110 - 00 - X5	燃油箱组件	2	MXR
3J1 - 24240 - 10	. 燃油箱图形	1	适用于 MXR

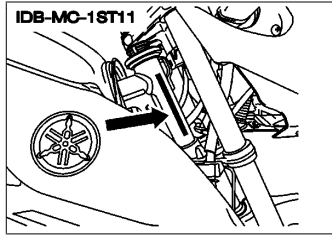
5. 请注意插图只用于找寻零件号码时参照，并不适用于组装。组装时，请使用适用的维修手册。



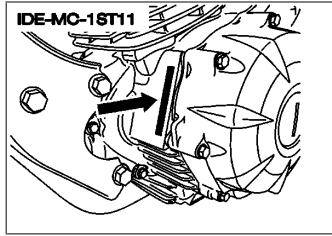
# 前言

## 7. 适用的系列号码

车架系列号



发动机系列号码



## 8. 适用的颜色记号 (\*标志表示型号颜色。)

省略记号	颜色名称 (英文)	颜色名称	颜色记号
BWC1 (*)	BLUISH WHITE COCKTAIL 1	浅蓝鸡尾白色 1	0390
DNPM1 (*)	DARK GRAYISH PURPLE METALLIC 1	浅紫灰黑色	0740
MBL2	MAT BLACK 2	无光泽黑	0582
RM7 (*)	RED METALLIC 7	金属红色 7	1218
S3	SILVER 3	银 3	0791
SMX (*)	BLACK METALLIC X	金属黑色	0903
YB	YAMAHA BLACK	雅马哈黑色	0033

## 9. 适用的初始系列号码

车架系列号

系列号码	数量栏名称	型号记号

发动机系列号码

系列号码	数量栏名称	型号记号





# 目录

## 发动机

气缸	1
曲柄·活塞	2
阀门	3
凸轮轴·链条	4
油泵	5
进气门	6
排气装置	8
曲轴箱	9
曲轴箱盖 1	10
起动离合器	11
离合器	12
传动	13
换挡凸轮·拨叉	15
变速杆	16

## 车体

车架	17
挡泥板	18
侧盖	19
后臂·悬挂	20
操纵系统	21
前叉	22
油箱	24
座位	26
前轮	27
前制动器卡钳	28
后轮	29
操纵手柄·钢索	31
前主缸	32
搁脚·支架	33
发电机	35
起动电机	36
转向灯	37
仪表	38
前大灯	39
尾灯	40
手柄开关·杆	41
电气系统 1	42
电气系统 2	43

## 索引

零件号码索引	44
--------	----

# CONTENTS

## ENGINE

CYLINDER.....	1
CRANKSHAFT & PISTON.....	2
VALVE.....	3
CAMSHAFT & CHAIN.....	4
OIL PUMP.....	5
INTAKE.....	6
EXHAUST.....	8
CRANKCASE.....	9
CRANKCASE COVER 1.....	10
STARTER CLUTCH.....	11
CLUTCH.....	12
TRANSMISSION.....	13
SHIFT CAM & FORK.....	15
SHIFT SHAFT.....	16

## CHASSIS

FRAME.....	17
FENDER.....	18
SIDE COVER.....	19
REAR ARM & SUSPENSION.....	20
STEERING.....	21
FRONT FORK.....	22
FUEL TANK.....	24
SEAT.....	26
FRONT WHEEL.....	27
FRONT BRAKE CALIPER.....	28
REAR WHEEL.....	29
STEERING HANDLE & CABLE.....	31
FRONT MASTER CYLINDER.....	32
STAND & FOOTREST.....	33
GENERATOR.....	35
STARTING MOTOR.....	36
FLASHER LIGHT.....	37
METER.....	38
HEADLIGHT.....	39
TAILLIGHT.....	40
HANDLE SWITCH & LEVER.....	41
ELECTRICAL 1.....	42
ELECTRICAL 2.....	43

## INDEX

NUMERICAL INDEX.....	44
----------------------	----

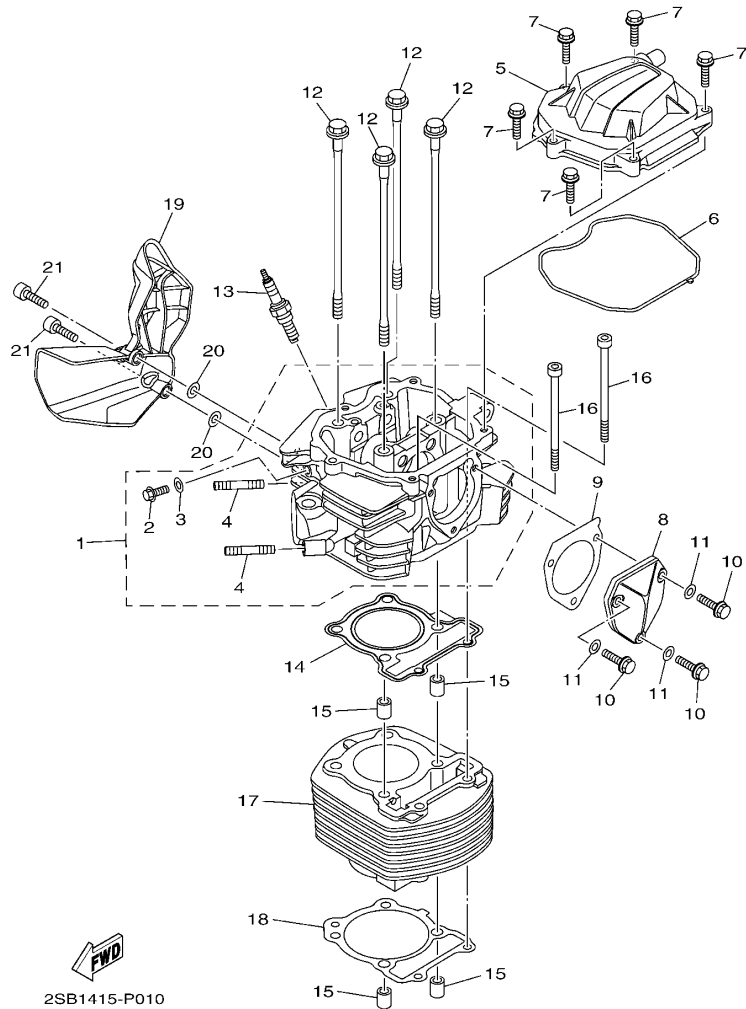
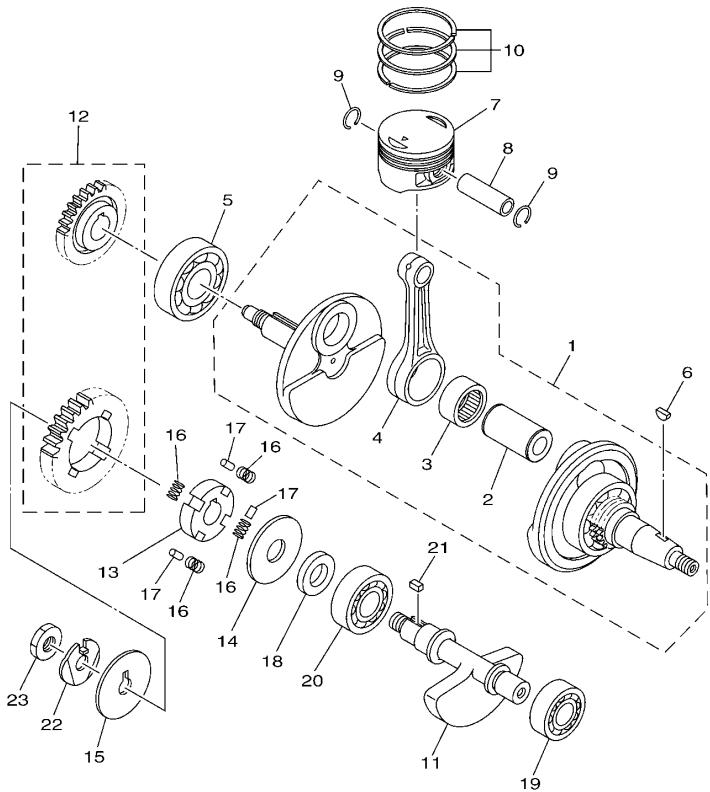


FIG. 1 气缸

CYLINDER

参照 号码	零件号码 PART NO.	零件名称 DESCRIPTION	2SB1				备注 REMARKS
1	2SB-E1111-00	气缸头 1 HEAD, CYLINDER 1	1				
2	95022-06012	凸缘螺栓 BOLT, FLANGE	1				
3	90430-06014	衬垫 GASKET	1				
4	95612-08635	双头螺栓 BOLT, STUD	2				
5	2SB-Y1119-00	气缸盖罩组合 COVER ASSY, CYLINDER HEAD	1				
6	2SB-E1193-00	气缸盖罩衬垫 1 GASKET, HEAD COVER 1	1				
7	95022-06025	凸缘螺栓 BOLT, FLANGE	5				
8	2SB-E1186-00	气缸头侧盖 2 COVER, CYLINDER HEAD SIDE 2	1				
9	2SB-E2435-00	衬垫 GASKET	1				
10	95022-06025	凸缘螺栓 BOLT, FLANGE	3				
11	90430-06014	衬垫 GASKET	3				
12	90105-08197	凸缘螺栓 BOLT, FLANGE	4				
13	94700-00415	火花塞 PLUG, SPARK (NGK CPR8EA)	1				
14	2SB-E1181-00	气缸头垫片 1 GASKET, CYLINDER HEAD 1	1				
15	91810-14809	定位销 PIN, DOWEL	4				
16	90110-06304	六角头插座螺栓 BOLT, HEXAGON SOCKET HEAD	2				
17	2SB-E1310-00	气缸 CYLINDER	1				
18	2SB-E1351-00	气缸衬垫 GASKET, CYLINDER	1				
19	2SB-E2661-00	导风盖 DUCT	1				
20	90201-05803	平垫圈 WASHER, PLATE	2				
21	90110-06846	六角头插座螺栓 BOLT, HEXAGON SOCKET HEAD	2				



  
2SB1415-P020

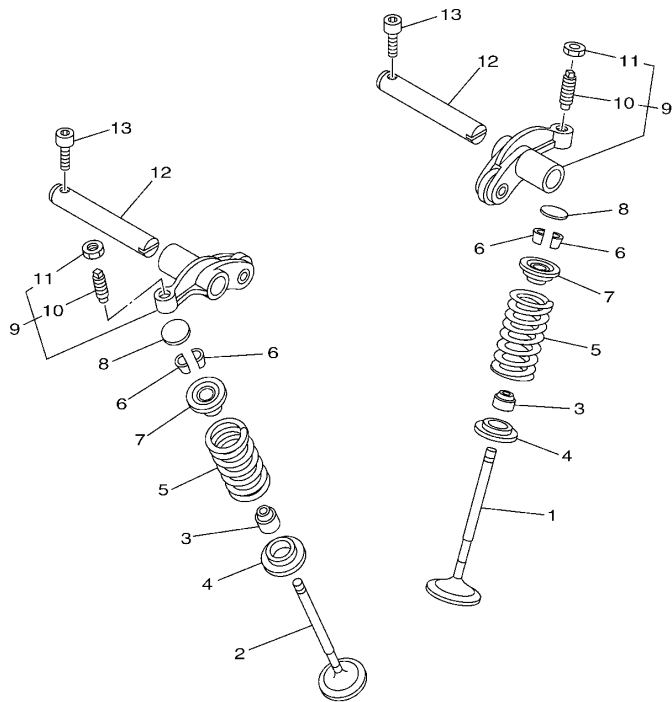
FIG. 2 曲柄·活塞

CRANKSHAFT & PISTON

参照 号码	零件号码 PART NO.	零件名称 DESCRIPTION	2SB1				备注 REMARKS
1	2SB-W1140-00	曲柄连杆组合 CRANKSHAFT ASSY	1				
2	2SB-E1681-00	. 曲柄销 1 .PIN, CRANK 1	1				
3	93310-628YA	. 轴承 .BEARING	1				
4	2SB-E1651-00	. 连杆 .ROD, CONNECTING	1				
5	93306-305XB	轴承 BEARING	1				
6	90280-03017	半圆键 KEY, WOODRUFF	1				
7	2SB-E1631-00	活塞 (STD) PISTON (STD)	1				
8	2SB-E1633-00	活塞销 PIN, PISTON	1				
9	93450-16812	卡环 CIRCLIP	2				
10	2SB-W1161-00	活塞环套件 PISTON RING SET	1				
11	2SB-E1454-00	平衡轴 1 WEIGHT 1	1				
12	2SB-Y1153-00	平衡驱动齿轮总成 GEAR,BALANCE WELGHT ASSY	1				
13	2SB-E1496-00	缓冲衬套 BOSS, BUFFER	1				
14	90201-15022	平垫圈 WASHER, PLATE	1				
15	90214-10006	爪形垫圈 WASHER, CLAW	1				
16	90501-18801	压簧 SPRING, COMPRESSION	4				
17	93604-10800	定位销 PIN, DOWEL	3				
18	90387-155J0	轴套 COLLAR	1				
19	93306-202XN	轴承 BEARING	1				
20	93306-253YH	轴承 BEARING	1				
21	90282-05010	平键 KEY, STRAIGHT	1				
22	90215-10284	制动垫圈 WASHER, LOCK	1				
23	90170-10012	螺母 NUT	1				

FIG. 3 阀门

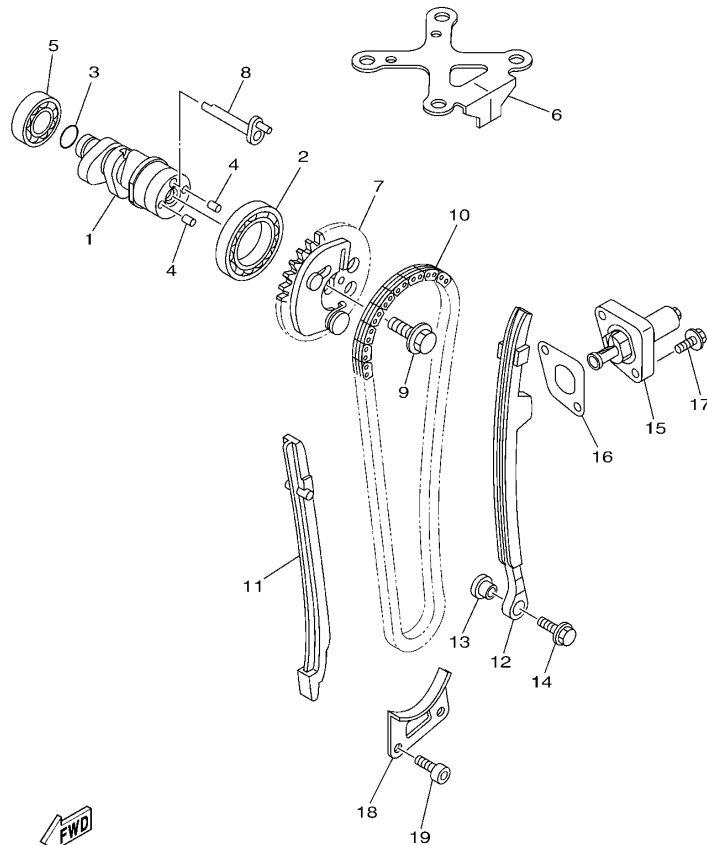
VALVE



参照 号码	零件号码 PART NO.	零件名称 DESCRIPTION	2SB1				备注 REMARKS
1	2SB-E2111-00	进气门 VALVE, INTAKE	1				
2	2SB-E2121-00	排气门 VALVE, EXHAUST	1				
3	2SB-E2119-00	气门油封 SEAL, VALVE STEM	2				
4	1JD-E2126-00	气门弹簧座 2 SEAT, VALVE SPRING 2	2				
5	2SB-E2113-00	气门内弹簧 SPRING, VALVE INNER	2				
6	1P6-E2118-00	气门锁夹 LOCK, VALVE SPRING RETAINER	4				
7	2SB-E2117-00	气门弹簧座 RETAINER, VALVE SPRING	2				
8	2SB-E2169-00	调整衬垫 PAD, ADJUSTING	2				
9	2SB-E2150-00	摇臂 VALVE ROCKER ARM ASSY	2				
10	2SB-E2159-00	气门调整螺钉 .SCREW, VALVE ADJUSTING	1				
11	90170-05302	螺母 .NUT	1				
12	2SB-E2156-00	摇臂轴 2 SHAFT, ROCKER 2	2				
13	91312-05016	螺栓 BOLT	2				

FIG. 4 凸轮轴·链条

CAMSHAFT & CHAIN

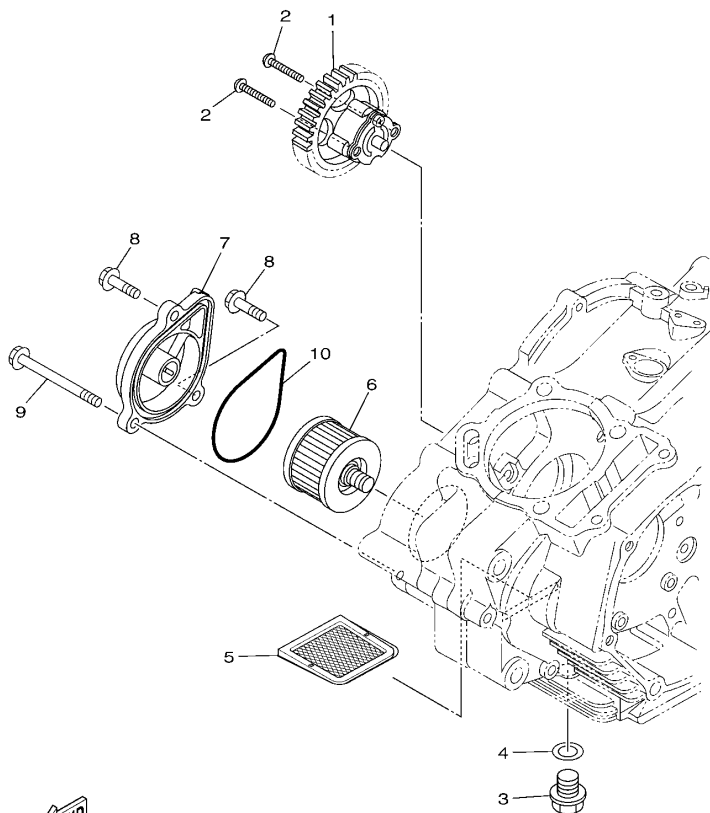


2SB1415-P040

参照 号码	零件号码 PART NO.	零件名称 DESCRIPTION	2SB1				备注 REMARKS
1	2SB-E2171-00	凸轮轴 1 CAMSHAFT 1	1				
2	93306-906X0	轴承 BEARING	1				
3	93210-12804	O 型环 O-RING	1				
4	93605-06800	定位销 PIN, DOWEL	2				
5	93306-002YP	轴承 BEARING	1				
6	2SB-E111F-00	面板 PLATE	1				
7	2SB-E2280-00	减压装置组合 DECOMPRESSION ASSY	1				
8	2SB-E2288-00	减压凸 CAM, DECOMPRESSION	1				
9	90105-08196	凸缘螺栓 BOLT, FLANGE	1				
10	94568-J2096	链条 CHAIN	1				
11	2SB-E2231-00	导向限位板 1 GUIDE, STOPPER 1	1				
12	2SB-E2241-00	导向限位板 2 GUIDE, STOPPER 2	1				
13	5VL-E5598-00	衬套 COLLAR	1				
14	90149-06829	螺钉 SCREW	1				
15	2SB-E2210-00	链条张紧器组合 TENSIONER ASSY, CAM CHAIN	1				
16	1JD-E2213-00	张紧器垫片 GASKET, TENSIONER CASE	1				
17	90105-06899	凸缘螺栓 BOLT, FLANGE	2				
18	2SB-E2437-00	限位板 STOPPER	1				
19	91312-06016	螺栓 BOLT	2				

FIG. 5 油泵

OIL PUMP



2SB1415-P050

参照 号码	零件号码 PART NO.	零件名称 DESCRIPTION	2SB1				备注 REMARKS
1	2SB-E3300-00	机油泵总成 OIL PUMP ASSY	1				
2	90111-05035	六角螺栓 BOLT,HEX. SOCKET BUTTON	2				
3	90340-12097	螺塞 PLUG, STRAIGHT SCREW	1				
4	90430-12227	衬垫 GASKET	1				
5	2D0-E3411-00	机油滤网 STRAINER, OIL	1				
6	2SB-E3440-00	滤油器滤芯组合 ELEMENT ASSY, OIL CLEANER	1				
7	2SB-E3447-00	滤油器滤芯盖 COVER, OIL ELEMENT	1				
8	95022-06020	凸缘螺栓 BOLT, FLANGE	2				
9	95022-06065	凸缘螺栓 BOLT, FLANGE	1				
10	93210-64800	O型环 O-RING	1				

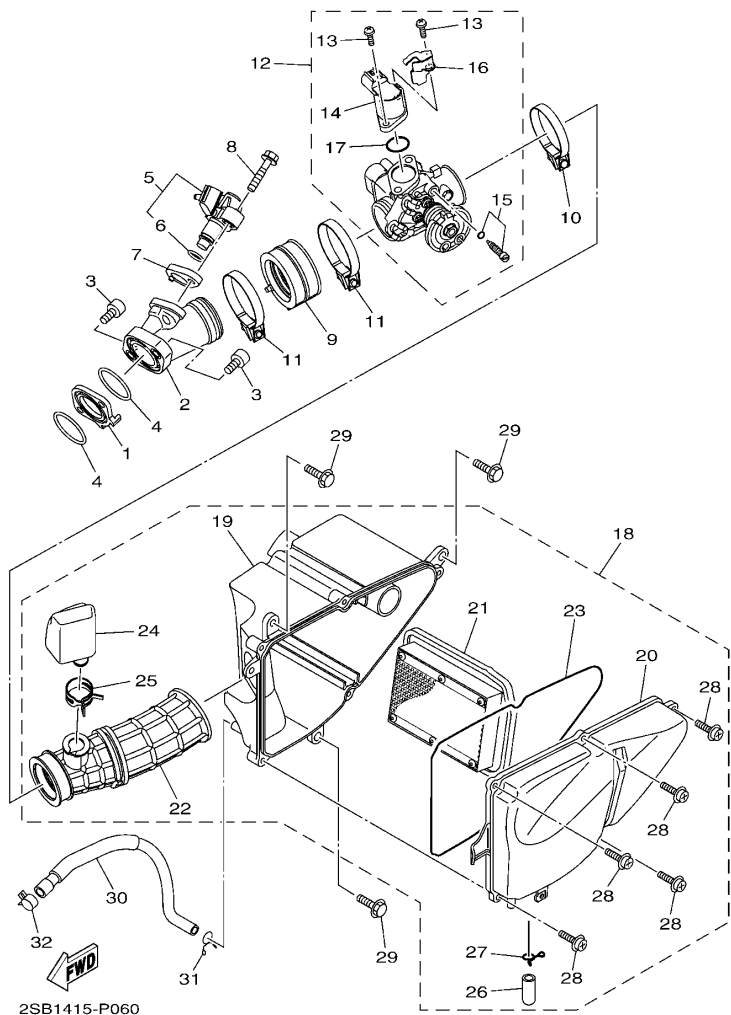


FIG. 6 进气门

INTAKE

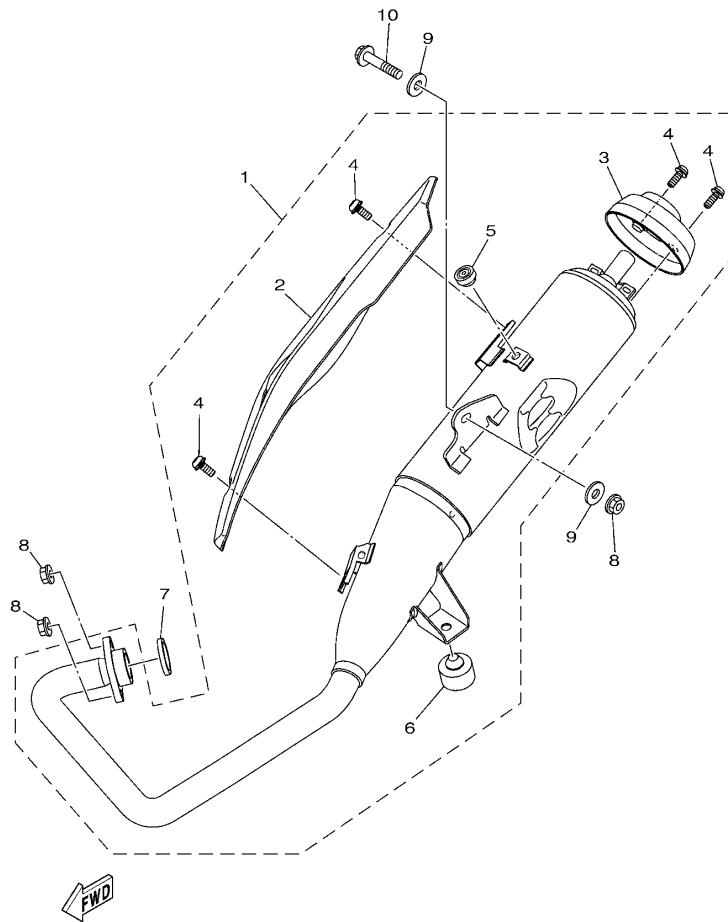
参照 号码	零件号码 PART NO.	零件名称 DESCRIPTION	2SB1				备注 REMARKS
1	2SB-E3595-00	接头 JOINT	1				
2	2SB-E3585-00	岐管 MANIFOLD	1				
3	91312-06025	螺栓 BOLT	2				
4	93210-30611	O型环 O-RING	2				
5	2GS-E3770-00	喷射器总成 INJECTOR ASSY	1				
6	5CA-E4147-00	.O型环 O-RING	1				
7	3D9-E3556-01	岐管衬垫 GASKET, MANIFOLD	1				
8	95812-06030	凸缘螺栓 BOLT, FLANGE	1				
9	2SB-E3635-00	进气管接头 1 JOINT, INTAKE 1	1				
10	90450-43805	软管夹组合 HOSE CLAMP ASSY	1				
11	18C-E3575-01	撞带 BAND	2				
12	2SB-E3750-00	节气门本体组合 THROTTLE BODY ASSY	1				
13	1ST-14216-00	.螺钉 SCREW	2				
14	1ST-1410H-00	.电磁阀 FUEL CUT SOLENOID VALVE	1				
15	1ST-14104-00	.空气调整螺钉套件 AIR SCREW SET	1				
16	1ST-14945-00	.压板 PLATE	1				
17	1ST-1416A-00	.O型环 O-RING	1				
18	2SB-E4410-00	空气净化器组合 AIR CLEANER ASSY.	1				
19	2SB-E4411-00	.空气净化器箱 1 CASE, AIR CLEANER 1	1				
20	2SB-E4412-00	.空气净化器箱盖 1 CAP, CLEANER CASE 1	1				
21	2SB-E4450-00	.空气净化器滤芯组合 ELEMENT ASSY, AIR CLEANER	1				
22	2SB-E4453-00	.空气净化器接头 1 JOINT, AIR CLEANER 1	1				
23	2SB-E4452-00	.密封垫 SEAL	1				
24	2SB-E4877-00	.共鸣箱 RESONATOR	1				
25	90467-20050	.卡环 CLIP	1				
26	2SB-E443E-00	.排水管 PIPE, DRAIN	1				
27	90467-12806	.卡环 CLIP	1				





FIG. 7 排气装置

EXHAUST



2SB1415-P070

参照 号码	零件号码 PART NO.	零件名称 DESCRIPTION	2SB1				备注 REMARKS
1	2SB-E4710-00	消音器总成 1 MUFFLER ASSY 1	1				
2	2SB-E4718-00	消音器保护器 1 .PROTECTOR, MUFFLER 1	1				
3	2SB-E4799-00	盖 .CAP	1				
4	90111-06807	六角螺栓 .BOLT,HEX. SOCKET BUTTON	4				
5	2TY-F4181-00	定位减震器 1 .DAMPER, LOCATING 1	1				
6	2SB-F7214-00	限位板 .STOPPER	1				
7	2SB-E4613-00	排气管衬垫 GASKET, EXHAUST PIPE	1				
8	95702-08500	螺母 NUT, FLANGE	3				
9	90201-088C4	平垫圈 WASHER, PLATE	2				
10	95812-08040	凸缘螺栓 BOLT, FLANGE	1				



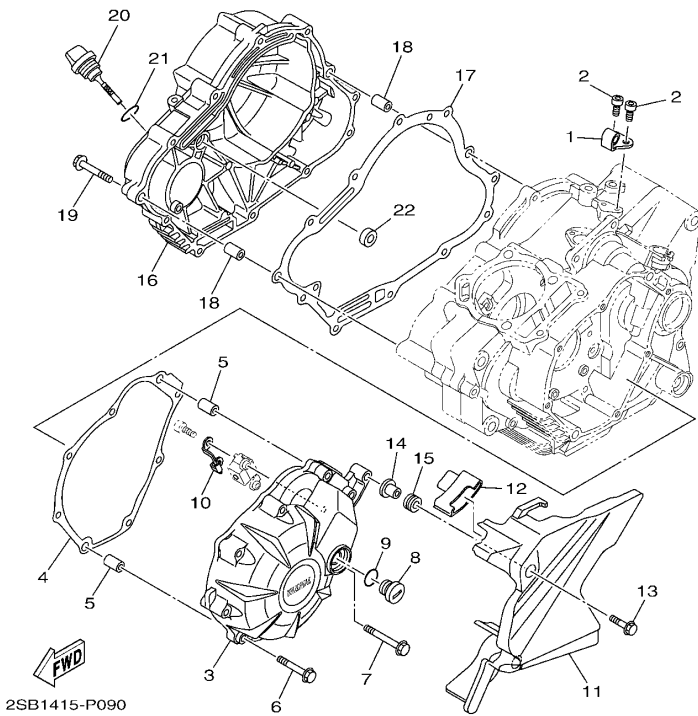
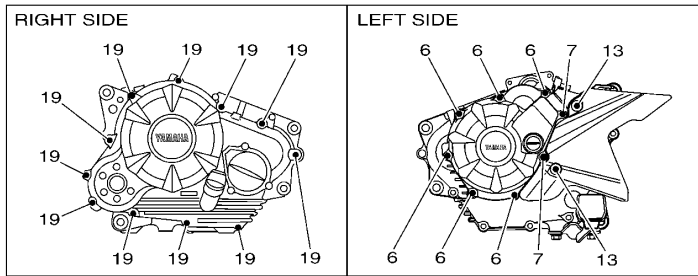


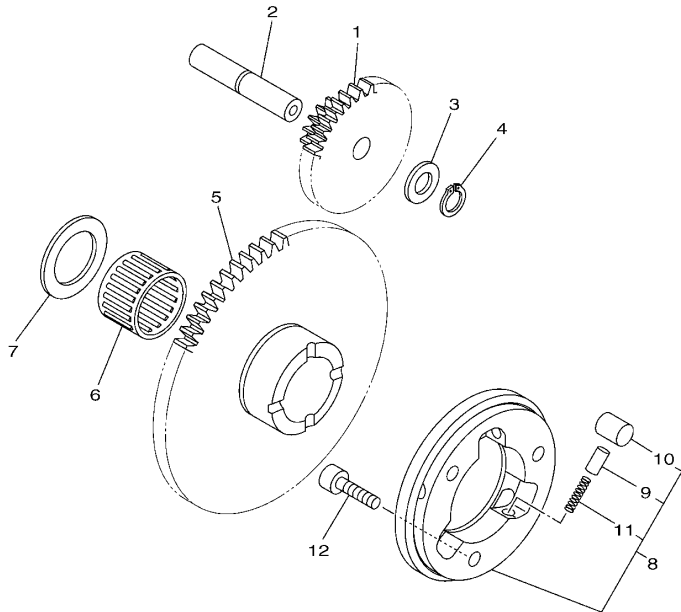
FIG. 9 曲轴箱盖 1

CRANKCASE COVER 1

参照 号码	零件号码 PART NO.	零件名称 DESCRIPTION	2SB1				备注 REMARKS
1	2SB-E5441-00	离合器钢索支架 HOLDER, CLUTCH CABLE	1				
2	91312-06016	螺栓 BOLT	2				
3	2SB-E5411-00	曲轴箱盖 1 COVER, CRANKCASE 1	1				
4	2SB-E5451-00	曲轴箱盖衬垫 1 GASKET, CRANKCASE COVER 1	1				
5	91810-14809	定位销 PIN, DOWEL	2				
6	95022-06040	凸缘螺栓 BOLT, FLANGE	6				
7	95022-06050	凸缘螺栓 BOLT, FLANGE	2				
8	1SF-E3455-00	塞 PLUG	1				
9	93210-14899	O型环 O-RING	1				
10	2SB-E5113-00	面板 PLATE	1				
11	2SB-E5418-00	链轮盖 1 COVER, CHAIN CASE	1				
12	2SB-E5377-00	进口导管 GUIDE, INLET	1				
13	95802-06020	凸缘螺栓 BOLT, FLANGE	2				
14	90387-068N6	轴套 COLLAR	2				
15	90480-12812	橡胶垫 GROMMET	2				
16	2SB-E5421-00	曲轴箱盖 2 COVER, CRANKCASE 2	1				
17	2SB-E5461-00	曲轴箱盖衬垫 2 GASKET, CRANKCASE COVER 2	1				
18	91810-14809	定位销 PIN, DOWEL	2				
19	95022-06040	凸缘螺栓 BOLT, FLANGE	11				
20	2SB-E5362-00	油标塞 PLUG, OIL LEVEL	1				
21	93210-19809	O型环 O-RING	1				
22	93101-10800	油封 OIL SEAL	1				

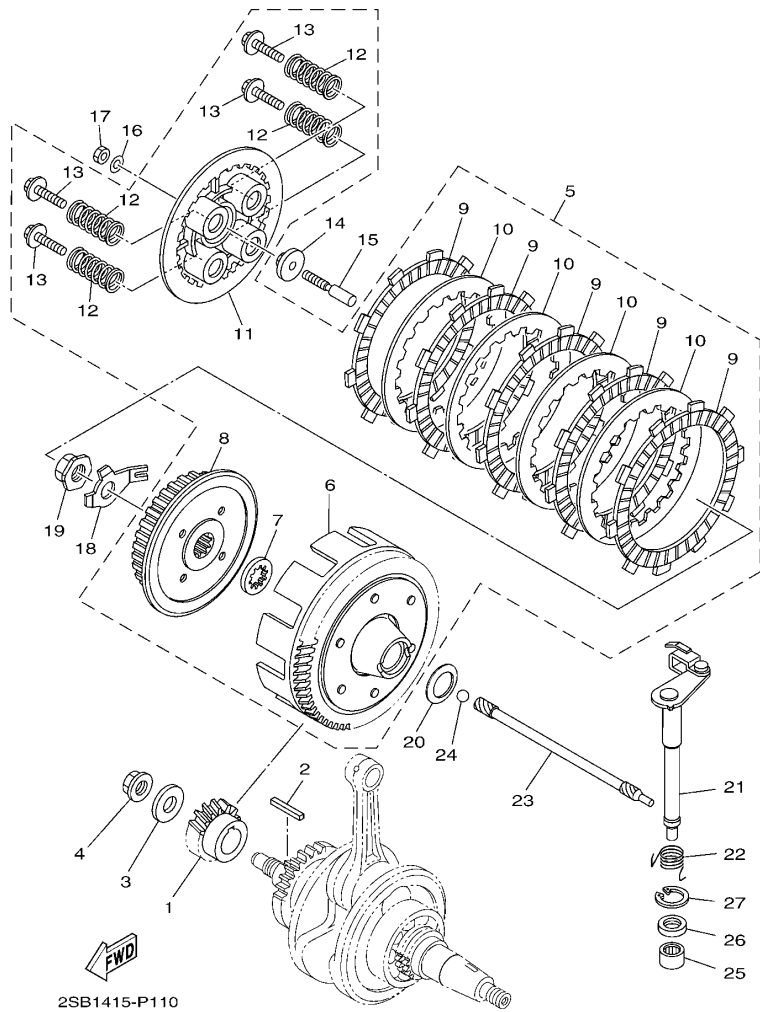
FIG. 10 起动离合器

STARTER CLUTCH



参照 号码	零件号码 PART NO.	零件名称 DESCRIPTION	2SB1				备注 REMARKS
1	2SB-E5514-00	齿轮 2 GEAR 2	1				
2	2SB-E5521-00	轴 1 SHAFT 1	1				
3	90201-105E8	平垫圈 WASHER, PLATE	1				
4	99009-10400	卡环 CIRCLIP	1				
5	2SB-E5524-00	起动齿轮 WHEEL, STARTER	1				
6	93310-325X7	轴承 BEARING	1				
7	90201-258D7	平垫圈 WASHER, PLATE	1				
8	2SB-E5580-00	起动离合器外部组合 STARTER CLUTCH OUTER ASSY	1				
9	2SB-E5583-00	. 起动离合器弹簧盖 .CAP, STARTER CLUTCH SPRING	3				
10	2SB-E5614-00	. 定位销 .PIN, DOWEL	3				
11	90501-03802	. 压簧 .SPRING, COMPRESSION	3				
12	91312-06020	螺栓 BOLT	3				

  
2SB1415-P100

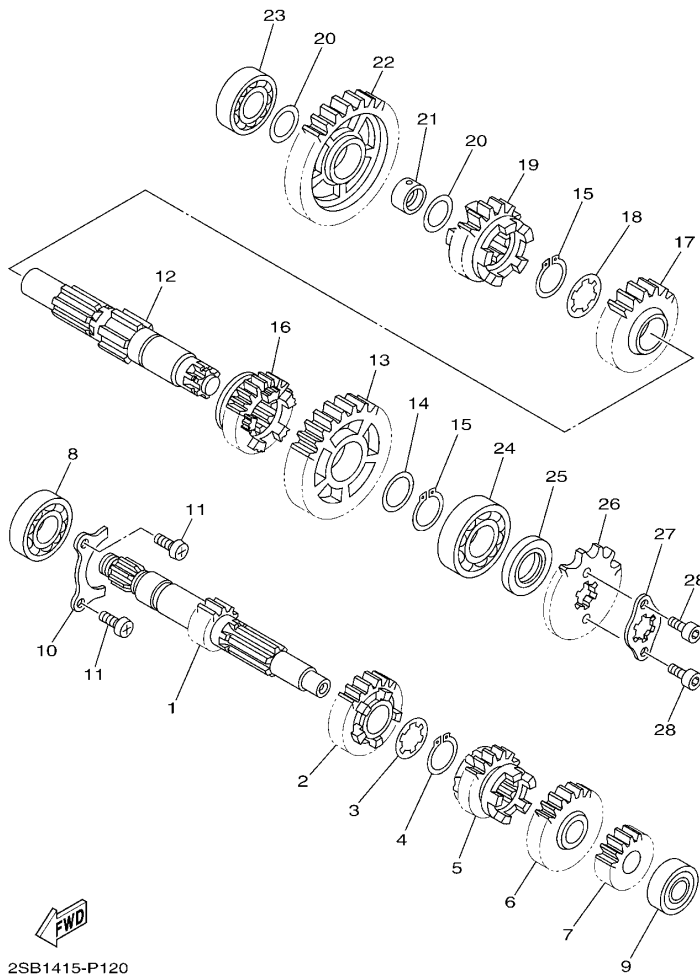


2SB1415-P110

FIG. 11 离合器

CLUTCH

参照 号码	零件号码 PART NO.	零件名称 DESCRIPTION	2SB1				备注 REMARKS
1	2SB-E6111-00	初级驱动齿轮 GEAR, PRIMARY DRIVE	1				
2	90282-05805	平键 KEY, STRAIGHT	1				
3	90201-12820	平垫圈 WASHER, PLATE	1				
4	90179-12803	螺母 NUT	1				
5	2SB-E6300-00	离合器总成 CLUTCH ASSY	1				
6	2SB-E6150-00	从动齿轮组合 .PRIMARY DRIVEN GEAR COMP.	1				
7	2SB-E6154-00	推板 1 .PLATE, THRUST 1	1				
8	2SB-E6371-00	离合器轮毂 .BOSS, CLUTCH	1				
9	2SB-E6321-00	摩擦片 .PLATE, FRICTION	5				
10	2SB-E6324-00	离合器片 1 .PLATE, CLUTCH 1	4				
11	2SB-E6351-00	压板 1 .PLATE, PRESSURE 1	1				
12	2SB-E6333-00	离合器弹簧 1 .SPRING, CLUTCH 1	4				
13	2SB-E6337-00	弹簧螺钉 .SCREW, SPRING	4				
14	4FP-E6358-00	推板 PLATE, PUSH	1				
15	2SB-E6356-00	推杆 1 ROD, PUSH 1	1				
16	92902-06200	垫圈 WASHER	1				
17	95302-06600	螺母 NUT, HEXAGON	1				
18	2SB-E6135-00	锁紧垫片 WASHER, LOCK	1				
19	90179-14806	螺母 NUT	1				
20	90208-20003	弹性挡圈 WASHER, CONICAL SPRING	1				
21	2SB-E6380-00	推杆总成 PUSH LEVER ASSY	1				
22	2SB-E6345-00	回位弹簧 SPRING, RETURN	1				
23	2SB-E6357-00	推杆 2 ROD, PUSH 2	1				
24	93505-16814	滚珠 BALL	1				
25	93317-112X0	轴承 BEARING	1				
26	93102-12802	油封 OIL SEAL	1				
27	99009-20500	卡环 CIRCLIP	1				



2SB1415-P120

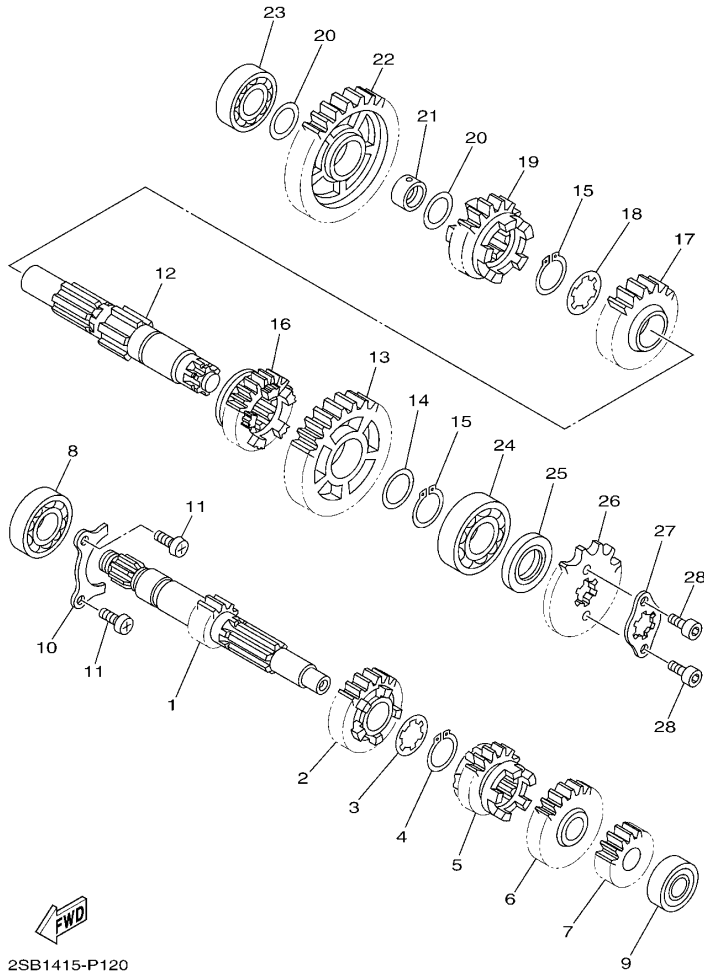
FIG. 12 传动

TRANSMISSION

参照 号码	零件号码 PART NO.	零件名称 DESCRIPTION	2SB1				备注 REMARKS
1	2SB-E7411-00	主轮轴 AXLE, MAIN (14T)	1				
2	2SB-E7141-00	四档主动齿轮 GEAR, 4TH PINION (22T)	1				
3	90209-17285	垫圈 WASHER	1				
4	93410-20809	卡环 CIRCLIP	1				
5	2SB-E7131-00	三档主动齿轮 GEAR, 3RD PINION (22T)	1				
6	2SB-E7151-00	五档主动齿轮 GEAR, 5TH PINION (24T)	1				
7	2SB-E7121-00	二档主动齿轮 GEAR, 2ND PINION (19T)	1				
8	93306-054YD	轴承 BEARING	1				
9	93306-201Y8	轴承 BEARING	1				
10	2SB-E7471-00	盖板 PLATE, COVER	1				
11	98512-06012	十字螺钉 SCREW, PAN HEAD	2				
12	2SB-E7421-00	驱动轴 AXLE, DRIVE	1				
13	2SB-E7221-00	二档从动齿轮 GEAR, 2ND WHEEL (34T)	1				
14	90201-22793	平垫圈 WASHER, PLATE	1				
15	93410-22820	卡环 CIRCLIP	2				
16	2SB-E7251-00	五档从动齿轮 GEAR, 5TH WHEEL (21T)	1				
17	2SB-E7231-00	三档从动齿轮 GEAR, 3RD WHEEL (29T)	1				
18	90209-18208	垫圈 WASHER	1				
19	2SB-E7241-00	四档从动齿轮 GEAR, 4TH WHEEL (23T)	1				
20	90201-178D3	平垫圈 WASHER, PLATE	2				
21	2SB-E7258-00	安装环 1 COLLAR 1	1				
22	2SB-E7211-00	一档从动齿轮 GEAR, 1ST WHEEL (38T)	1				
23	93306-203XM	轴承 BEARING	1				
24	93306-272X8	轴承 BEARING	1				
25	93102-22828	油封 OIL SEAL	1				
26	93823-14821	驱动链轮 SPROCKET, DRIVE (14T)	1				
27	2SB-E7456-00	驱动链轮挡圈 HOLDER, SPROCKET	1				

FIG. 12 传动

TRANSMISSION



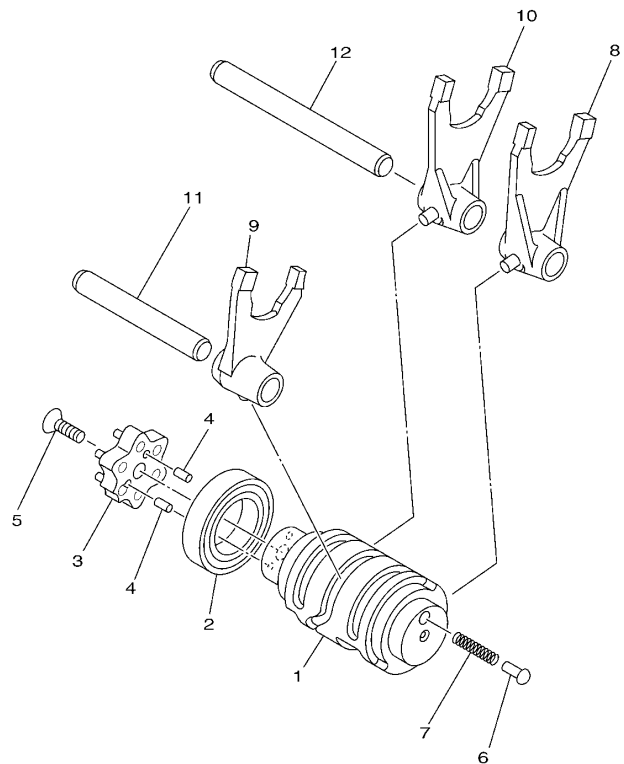
2SB1415-P120

参照 号码	零件号码 PART NO.	零件名称 DESCRIPTION	2SB1				备注 REMARKS
28	91312-05010	螺栓 BOLT	2				



FIG. 13 换挡凸轮·拨叉

SHIFT CAM & FORK

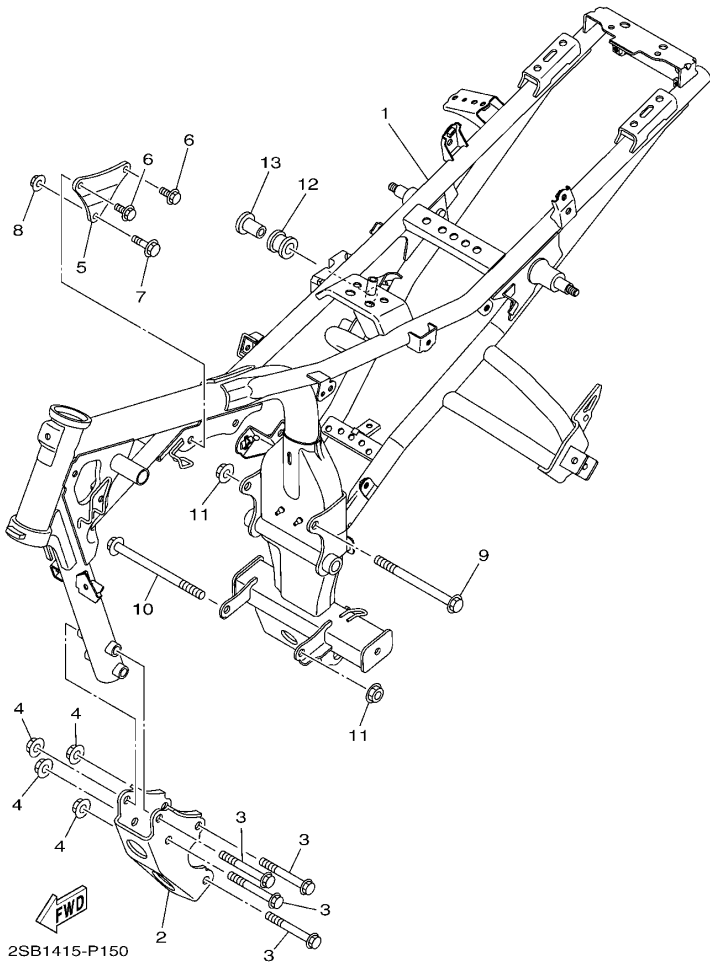


参照 号码	零件号码 PART NO.	零件名称 DESCRIPTION	2SB1				备注 REMARKS
1	2SB-E8541-00	换挡凸 CAM, SHIFT	1				
2	93306-905Y7	轴承 BEARING	1				
3	1BK-E8185-00	星形轮 SEGMENT	1				
4	93604-10837	定位销 PIN, DOWEL	2				
5	90151-06818	沉头螺钉 SCREW, COUNTERSUNK	1				
6	1JD-E8542-00	空挡触头 POINT, NEUTRAL	1				
7	90501-06805	压簧 SPRING, COMPRESSION	1				
8	2SB-E8511-00	换挡拨叉 1 FORK, SHIFT 1	1				
9	2SB-E8512-00	换挡拨叉 2 FORK, SHIFT 2	1				
10	2SB-E8513-00	换挡拨叉 3 FORK, SHIFT 3	1				
11	2SB-E8531-00	拨叉导杆 1 BAR, SHIFT FORK GUIDE 1	1				
12	2SB-E8535-00	拨叉导杆 2 BAR, SHIFT FORK GUIDE 2	1				



2SB1415-P130



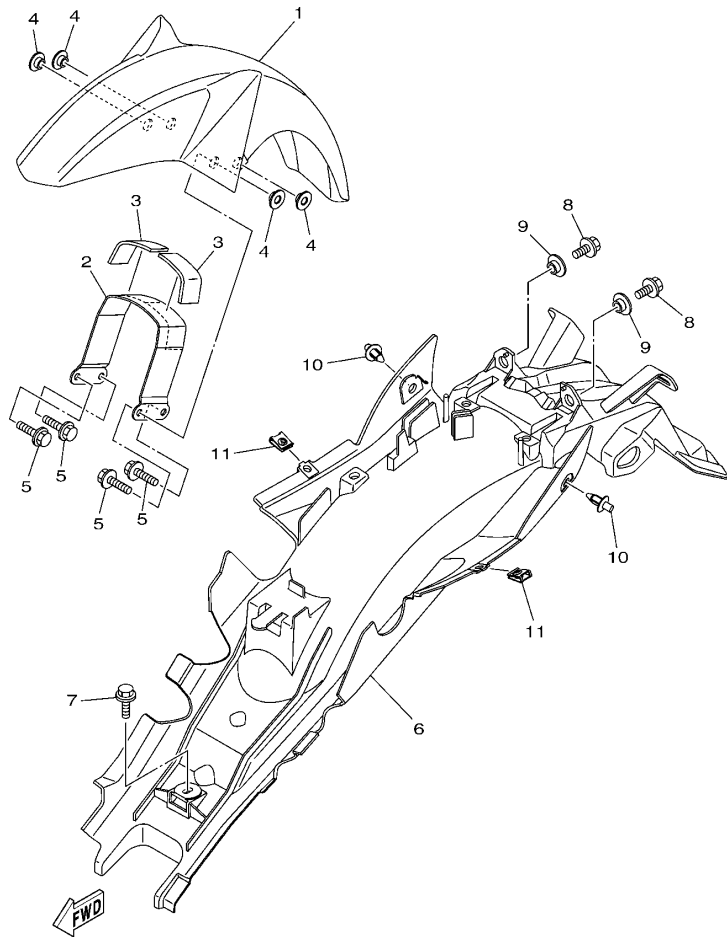


2SB1415-P150

FIG. 15 车架

FRAME

参照 号码	零件号码 PART NO.	零件名称 DESCRIPTION	2SB1				备注 REMARKS
1	2SB-F1110-00	车架组合 FRAME COMP.	1				
2	2SB-F1316-00	发动机支承 2 STAY, ENGINE 2	1				
3	90105-10282	凸缘螺栓 BOLT, FLANGE	4				
4	95602-10200	自锁螺母 NUT, U FLANGE	4				
5	2SB-F1317-00	发动机支承 3 STAY, ENGINE 3	1				
6	95812-08016	凸缘螺栓 BOLT, FLANGE	2				
7	90105-088E4	凸缘螺栓 BOLT, FLANGE	1				
8	90185-08008	自锁螺母 NUT, SELF-LOCKING	1				
9	90105-10176	凸缘螺栓 BOLT, FLANGE	1				
10	90105-10861	凸缘螺栓 BOLT, FLANGE	1				
11	95602-10200	自锁螺母 NUT, U FLANGE	2				
12	1JD-E4747-00	消音器减震器 DAMPER, MUFFLER	1				
13	90387-08830	轴套 COLLAR	1				



2SB1415-P160

FIG. 16 挡泥板

FENDER

参照 号码	零件号码 PART NO.	零件名称 DESCRIPTION	2SB1				备注 REMARKS
1	2SB-F1511-00-P0	前挡泥板 FENDER, FRONT	1				UR 无光泽黑 金属黑色车用 UR MBL2 FOR SMX
	2SB-F1511-00-P1	前挡泥板 FENDER, FRONT	1				UR 金属红色 7 车用 UR FOR RM7
	2SB-F1511-00-P2	前挡泥板 FENDER, FRONT	1				UR 浅蓝鸡尾白色 1 车用 UR FOR BWC1
	2SB-F1511-00-P3	前挡泥板 FENDER, FRONT	1				UR 银 3 浅紫灰黑色车用 UR S3 FOR DNPM1
2	18C-F1513-01	挡泥板支架 1 STAY, FENDER 1	1				
3	5VL-F1746-00	减震垫 DAMPER	2				
4	90387-07818	轴套 COLLAR	4				
5	95822-06020	凸缘螺栓 BOLT, FLANGE	4				
6	2SB-F1611-00	后挡泥板 FENDER, REAR	1				
7	90119-068B7	带垫螺栓 BOLT, WITH WASHER	1				
8	95822-06016	凸缘螺栓 BOLT, FLANGE	2				
9	90387-07818	轴套 COLLAR	2				
10	90269-06008	铆钉 RIVET	2				
11	90183-05807	弹性螺母 NUT, SPRING	2				

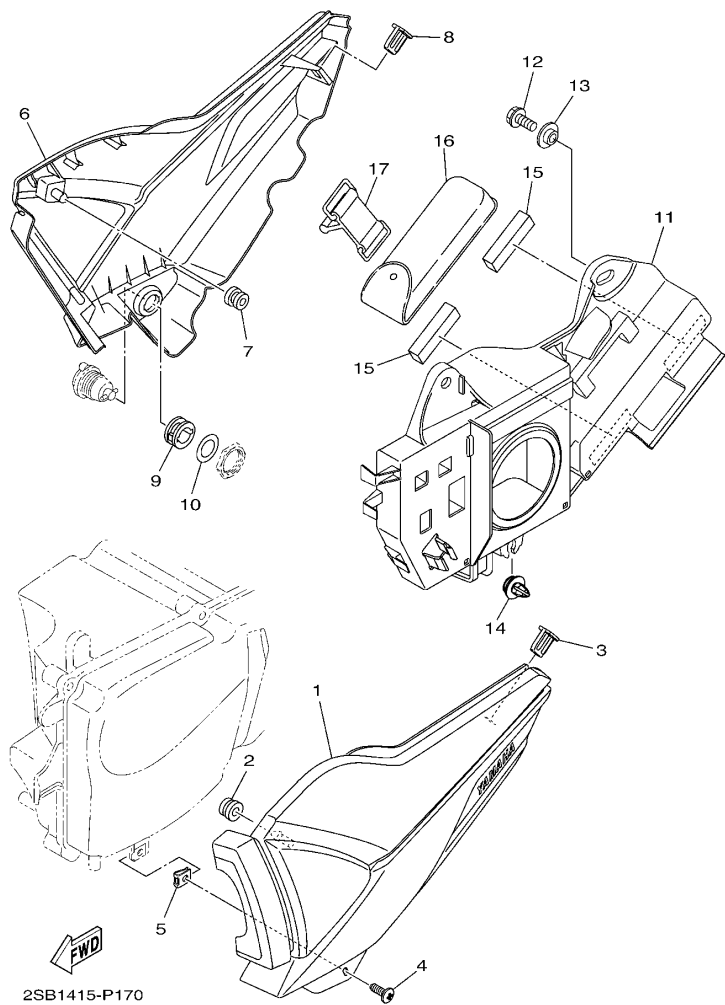


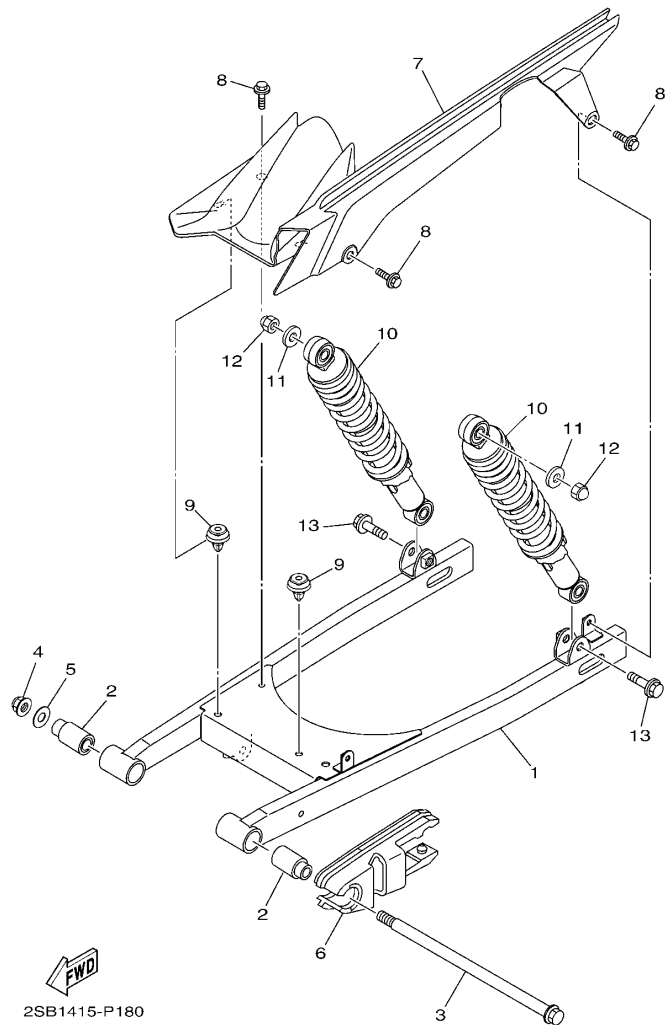
FIG. 17 侧盖

SIDE COVER

参照 号码	零件号码 PART NO.	零件名称 DESCRIPTION	2SB1				备注 REMARKS
1	2SB-Y2171-00	侧盖 1 COVER, SIDE 1	1				
2	90480-13837	橡胶垫 GROMMET	1				
3	2SB-F1778-00	定位减震器 1 DAMPER, LOCATING 1	1				
4	97702-50016	自攻螺钉 SCREW, TAPPING	1				
5	90183-05807	弹性螺母 NUT, SPRING	1				
6	2SB-Y2172-00	侧盖 2 COVER, SIDE 2	1				
7	90480-13837	橡胶垫 GROMMET	1				
8	2SB-F1778-00	定位减震器 1 DAMPER, LOCATING 1	1				
9	90480-24186	橡胶垫 GROMMET	1				
10	90201-228F6	平垫圈 WASHER, PLATE	1				
11	2SB-F177G-00	蓄电池盒 BOX, BATTERY	1				
12	90159-06864	带垫螺钉 SCREW, WITH WASHER	2				
13	90387-07818	轴套 COLLAR	2				
14	90269-09005	铆钉 RIVET	1				
15	5VL-F1541-00	减震垫 1 DAMPER 1	2				
16	2SB-F8100-00	随车工具 TOOL KIT	1				
17	5VL-F811G-01	撞带 BAND	1				

FIG. 18 后臂·悬挂

REAR ARM & SUSPENSION



参照 号码	零件号码 PART NO.	零件名称 DESCRIPTION	2SB1				备注 REMARKS
1	2SB-F2110-00	后臂组合 REAR ARM COMP.	1				
2	90388-14801	减震垫 DAMPER	2				
3	2SB-F2141-00	后臂转轴 SHAFT, PIVOT	1				
4	95602-12200	自锁螺母 NUT, SELF-LOCKING	1				
5	90201-12819	平垫圈 WASHER, PLATE	1				
6	2SB-F2151-00	链条保护套 SEAL, GUARD	1				
7	2SB-F1650-00	后挡泥板盖组合 REAR FENDER COMP.	1				
8	90119-068B7	带垫螺栓 BOLT, WITH WASHER	3				
9	90269-09005	铆钉 RIVET	2				
10	2SB-F2210-01	后减震器总成 SHOCK ABSORBER ASSY, REAR	2				
11	90201-108C7	平垫圈 WASHER, PLATE	2				
12	90176-10804	盖型螺母 NUT, CROWN	2				
13	95812-10035	凸缘螺栓 BOLT, FLANGE	2				

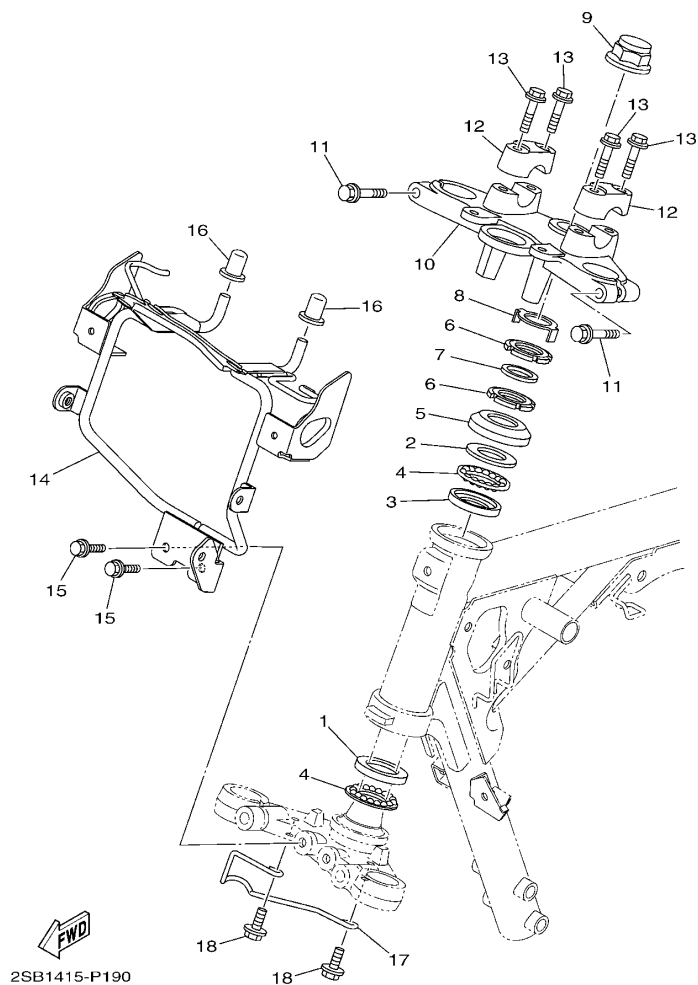


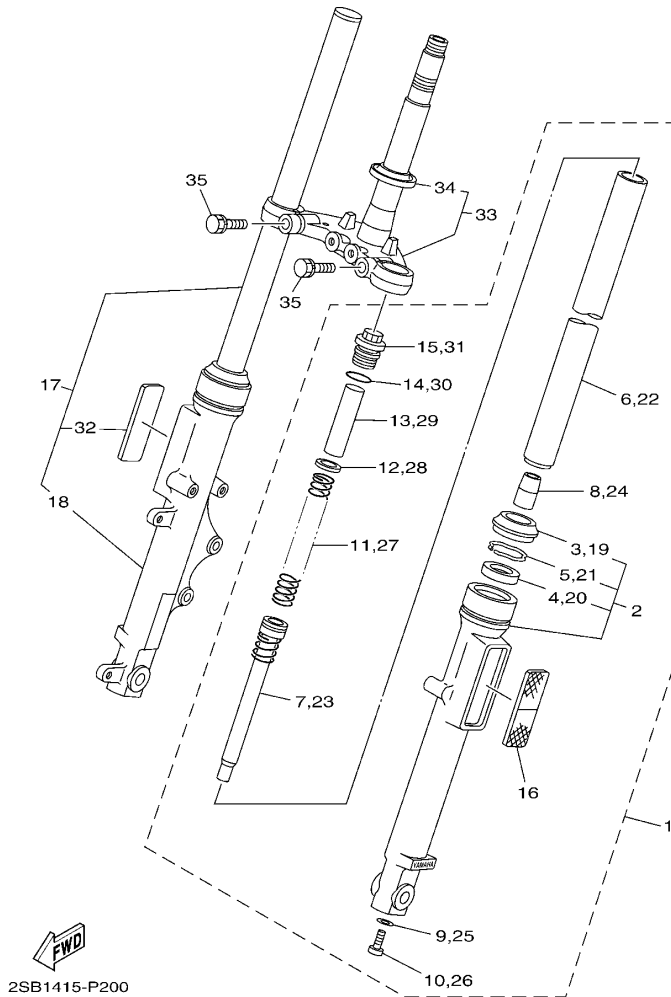
FIG. 19 操纵系统

STEERING

参照 号码	零件号码 PART NO.	零件名称 DESCRIPTION	2SB1				备注 REMARKS
1	1KL-F3412-00	轴承座圈 2 RACE, BALL 2	1				
2	4FP-F3411-00	轴承座圈 1 RACE, BALL 1	1				
3	4FP-F3412-00	轴承座圈 2 RACE, BALL 2	1				
4	5VL-F341E-00	保持架 RETAINER, BALL BEARING	2				
5	4GU-F3416-00	滚珠座圈盖 2 COVER, BALL RACE 2	1				
6	90179-25806	螺母 NUT	2				
7	90202-26142	平垫圈 WASHER, PLATE	1				
8	5VL-F3418-01	专用垫圈 WASHER, SPECIAL	1				
9	90176-22801	盖型螺母 NUT, CROWN	1				
10	5VL-F3435-00-33	手把座 CROWN, HANDLE	1				雅马哈黑色 YB
11	95022-08040	凸缘螺栓 BOLT, FLANGE	2				
12	5VL-F3441-00	手把上夹持器 HOLDER, HANDLE UPPER	2				
13	95022-08035	凸缘螺栓 BOLT, FLANGE	4				
14	2SB-F3174-00	前照灯支承 STAY, HEADLIGHT	1				
15	95822-06012	凸缘螺栓 BOLT, FLANGE	2				
16	2SB-F317J-00	减震垫 1 DAMPER 1	2				
17	2SB-F3389-00	钢索导框 GUIDE, CABLE	1				
18	95822-06012	凸缘螺栓 BOLT, FLANGE	2				

FIG. 20 前叉

FRONT FORK

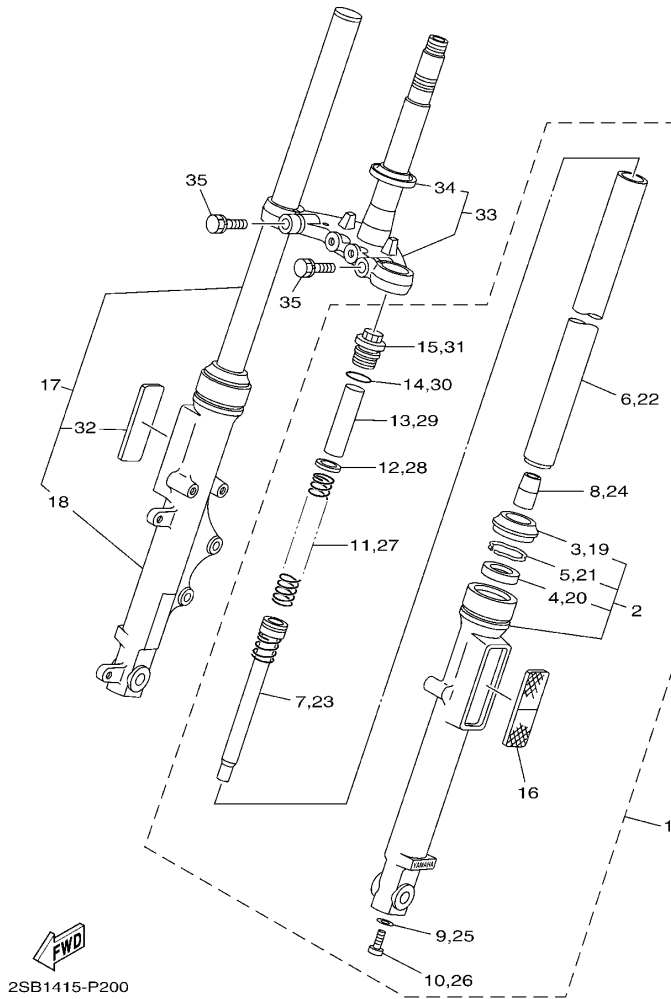


参照 号码	零件号码 PART NO.	零件名称 DESCRIPTION	2SB1				备注 REMARKS
1	2SB-F3102-00	前叉组合 (左边) FRONT FORK ASSY (L.H)	1				
2	5VL-F3106-D0	.外管组件 (左边) .OUTER TUBE COMP.	1				
3	1ST-F3144-00	..防尘罩 ..SEAL, DUST	1				
4	1ST-F3145-00	..油封 ..OIL SEAL	1				
5	5AP-F3153-00	..扣环 ..RING, SNAP	1				
6	5HH-F3110-22	..内管组件 1 ..INNER TUBE COMP.1	1				
7	1ST-F3170-00	..前叉气缸组合 ..CYLINDER COMP., FRONT FORK	1				
8	4GU-F3173-01	..锥形主轴 ..SPINDLE, TAPER	1				
9	4TU-F3479-00	..衬垫 ..GASKET	1				
10	5LK-F3356-01	..螺栓 2 ..BOLT 2	1				
11	1ST-F3141-00	..前叉弹簧 ..SPRING, FRONT FORK	1				
12	5AP-F3427-00	..垫圈 ..WASHER	1				
13	1ST-F3118-00	..衬套 ..SPACER	1				
14	5AP-F3147-00	..O型环 ..O-RING	1				
15	1ST-F3111-00	..顶盖螺栓 ..BOLT, CAP	1				
16	5VL-H5110-30	..前反光片总成 ..REFLECTOR ASSY	1				
17	2SB-F3103-00	前叉组合 (右边) FRONT FORK ASSY (R.H)	1				
18	5VL-F3107-D0	..外管组件 (右边) ..OUTER TUBE COMP. (R.H)	1				
19	1ST-F3144-00	..防尘罩 ..SEAL, DUST	1				
20	1ST-F3145-00	..油封 ..OIL SEAL	1				
21	5AP-F3153-00	..扣环 ..RING, SNAP	1				
22	5HH-F3110-22	..内管组件 1 ..INNER TUBE COMP.1	1				
23	1ST-F3170-00	..前叉气缸组合 ..CYLINDER COMP., FRONT FORK	1				
24	4GU-F3173-01	..锥形主轴 ..SPINDLE, TAPER	1				
25	4TU-F3479-00	..衬垫 ..GASKET	1				
26	5LK-F3356-01	..螺栓 2 ..BOLT 2	1				
27	1ST-F3141-00	..前叉弹簧 ..SPRING, FRONT FORK	1				

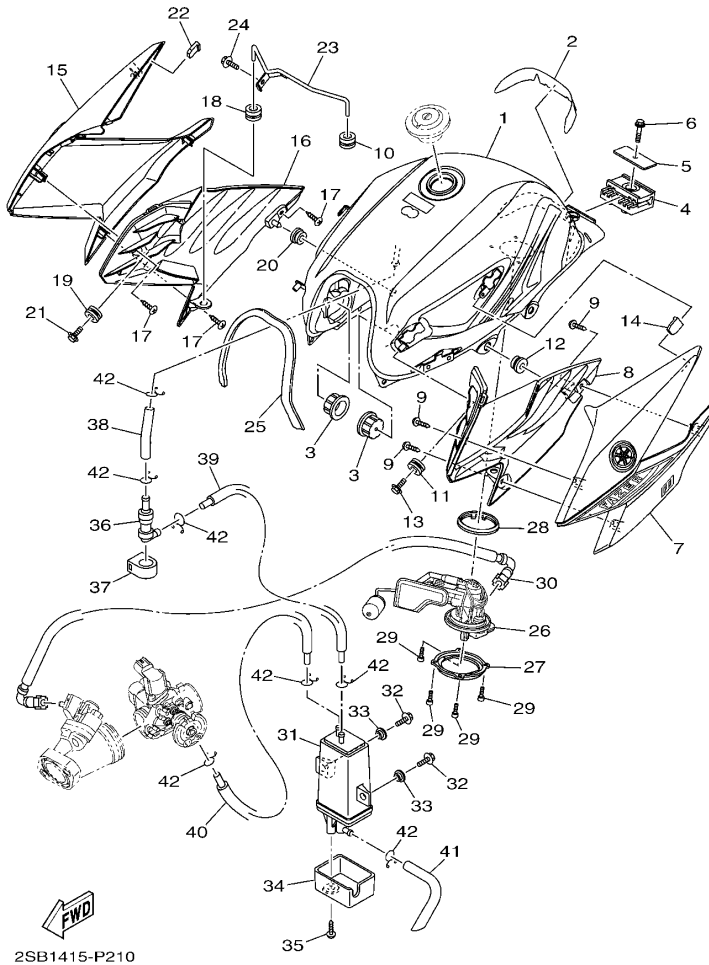


FIG. 20 前叉

FRONT FORK



参照 号码	零件号码 PART NO.	零件名称 DESCRIPTION	2SB1				备注 REMARKS
28	5AP-F3427-00	. 垫圈 .WASHER	1				
29	1ST-F3118-00	. 衬套 .SPACER	1				
30	5AP-F3147-00	. O型环 .O-RING	1				
31	1ST-F3111-00	. 顶盖螺栓 .BOLT, CAP	1				
32	5VL-H5110-30	. 前反光片总成 .REFLECTOR ASSY	1				
33	1ST-F331X-00	下侧托架 BRACKET, UNDER	1				
34	4FP-F3411-10	. 轴承座圈 1 .RACE, BALL 1	1				
35	5VL-F3346-01	螺栓 1 BOLT 1	2				

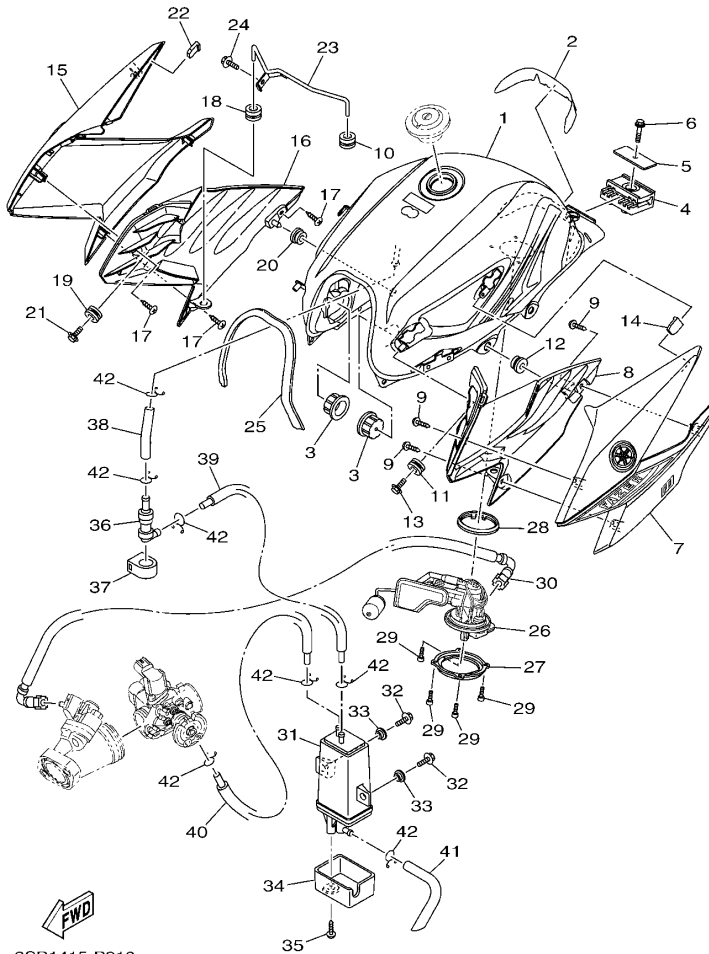


2SB1415-P210

FIG. 21 油箱

FUEL TANK

参照 号码	零件号码 PART NO.	零件名称 DESCRIPTION	2SB1			备注 REMARKS
1	2SB-W2411-00-P0	油箱组合 FUEL TANK ASSY	1			UR 金属黑色车用 UR FOR SMX
	2SB-W2411-00-P1	油箱组合 FUEL TANK ASSY	1			UR 金属红色 7 车用 UR FOR RM7
	2SB-W2411-00-P2	油箱组合 FUEL TANK ASSY	1			UR 浅蓝鸡尾白色 1 车用 UR FOR BWC1
	2SB-W2411-00-P3	油箱组合 FUEL TANK ASSY	1			UR 浅紫灰黑色车用 UR FOR DNPM1
2	2SB-F4141-00	油箱保护 PROTECTOR, FUEL TANK	1			
3	4FP-F4181-00	定位减震器 1 DAMPER, LOCATING 1	2			
4	2SB-F4182-00	定位减震器 2 DAMPER, LOCATING 2	1			
5	2SB-F4186-00	特制垫片 WASHER, SPECIAL	1			
6	95822-06030	凸缘螺栓 BOLT, FLANGE	1			
7	2SB-W137W-00-P0	导流罩 1 SCOOP, AIR 1	1			UR 无光泽黑 金属黑色车用 UR MBL2 FOR SMX
	2SB-W137W-00-P1	导流罩 1 SCOOP, AIR 1	1			UR 金属红色 7 车用 UR FOR RM7
	2SB-W137W-00-P2	导流罩 1 SCOOP, AIR 1	1			UR 浅蓝鸡尾白色 1 车用 UR FOR BWC1
	2SB-W137W-00-P3	导流罩 1 SCOOP, AIR 1	1			UR 银 3 浅紫灰黑色车用 UR S3 FOR DNPM1
8	2SB-F137U-00	通风盖 1 GUIDE, AIR 1	1			
9	97702-50016	自攻螺钉 SCREW, TAPPING	3			
10	90480-12835	橡胶垫 GROMMET	1			
11	90480-15878	橡胶垫 GROMMET	1			
12	90480-13837	橡胶垫 GROMMET	1			
13	95802-06010	凸缘螺栓 BOLT, FLANGE	1			
14	2SB-F411J-00	侧盖减震垫 DAMPER, SIDE COVER	1			
15	2SB-W137X-00-P0	导流罩 2 SCOOP, AIR 2	1			UR 无光泽黑 金属黑色车用 UR MBL2 FOR SMX
	2SB-W137X-00-P1	导流罩 2 SCOOP, AIR 2	1			UR 金属红色 7 车用 UR FOR RM7
	2SB-W137X-00-P2	导流罩 2 SCOOP, AIR 2	1			UR 浅蓝鸡尾白色 1 车用 UR FOR BWC1
	2SB-W137X-00-P3	导流罩 2 SCOOP, AIR 2	1			UR 银 3 浅紫灰黑色车用 UR S3 FOR DNPM1
16	2SB-F137V-00	通风盖 2 GUIDE, AIR 2	1			
17	97702-50016	自攻螺钉 SCREW, TAPPING	3			
18	90480-12835	橡胶垫 GROMMET	1			



2SB1415-P210

FIG. 21 油箱

FUEL TANK

参照 号码	零件号码 PART NO.	零件名称 DESCRIPTION	2SB1				备注 REMARKS
19	90480-15878	橡胶垫 GROMMET	1				
20	90480-13837	橡胶垫 GROMMET	1				
21	95802-06010	凸缘螺栓 BOLT, FLANGE	1				
22	2SB-F411J-00	侧盖减震垫 DAMPER, SIDE COVER	1				
23	2SB-F4216-00	支承 STAY	1				
24	95802-06010	凸缘螺栓 BOLT, FLANGE	1				
25	2SB-F4188-00	燃油箱嵌条 MOLD, FUEL TANK	1				
26	2SB-E3907-00	油泵组合 FUEL PUMP COMP.	1				
27	2SB-F4491-00	燃油泵托架 BRACKET, FUEL PUMP	1				
28	1DB-F414G-01	密封圈 SEAL	1				
29	91312-05010	螺栓 BOLT	4				
30	2SB-E3971-00	燃油管 1 PIPE, FUEL 1	1				
31	2SB-F4170-10	过滤缸总成 CANISTER ASSY	1				
32	90159-06864	带垫螺钉 SCREW, WITH WASHER	2				
33	90387-07818	轴套 COLLAR	2				
34	2SB-F419E-00	过滤盖 COVER, CANISTER	1				
35	97702-50016	自攻螺钉 SCREW, TAPPING	1				
36	18C-F4180-01	滚动阀组合 ROLL OVER VALVE ASSY	1				
37	4S0-F4135-00	线夹 1 CLAMP 1	1				
38	2SB-F4312-00	管 2 PIPE 2	1				
39	2SB-F4313-00	管 3 PIPE 3	1				
40	2SB-F4314-00	管 4 PIPE 4	1				
41	2SB-F4315-00	管 5 PIPE 5	1				
42	90467-09006	卡环 CLIP	7				

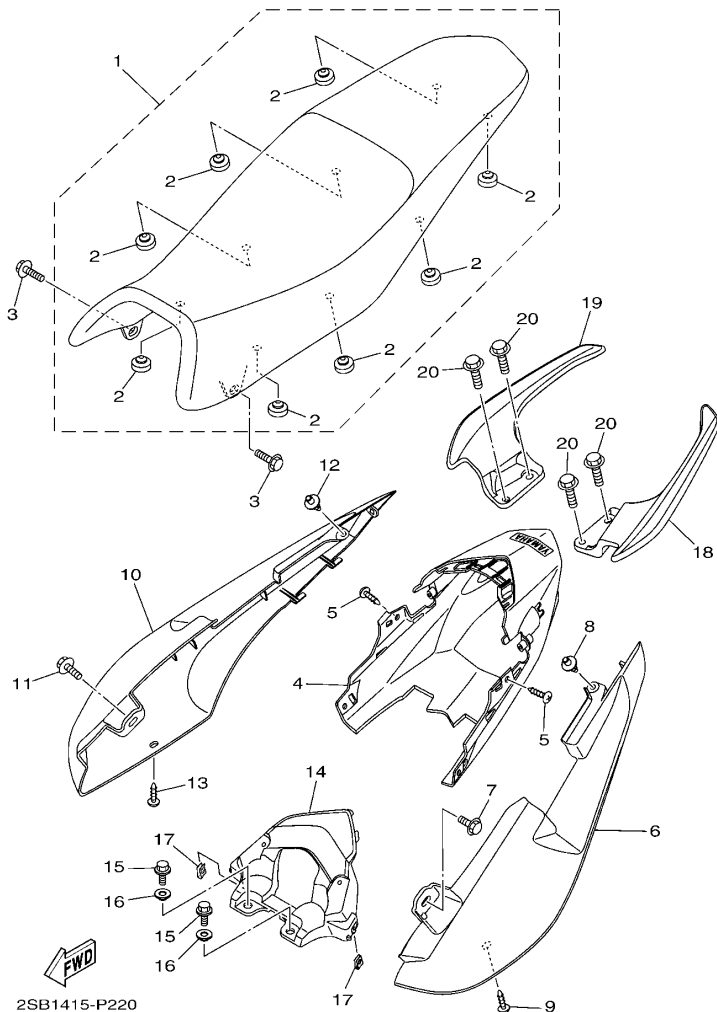


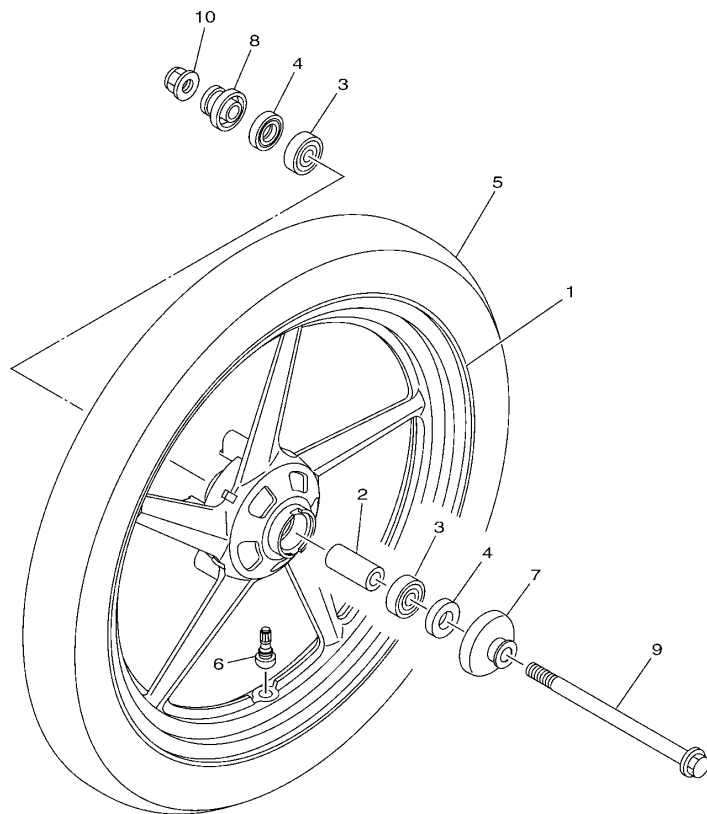
FIG. 22 座位

SEAT

参照 号码	零件号码 PART NO.	零件名称 DESCRIPTION	2SB1				备注 REMARKS
1	2SB-F4730-00	双人座垫组合 DOUBLE SEAT ASSY	1				
2	4TU-F4741-00	缓冲座 .PAD, SEAT	8				
3	90119-068B7	带垫螺栓 BOLT, WITH WASHER	2				
4	2SB-W4756-00	尾罩总成 TAIL COVER ASSY	1				
5	97702-50016	自攻螺钉 SCREW, TAPPING	2				
6	2SB-W471K-00-P0	尾罩总成 1 TAIL COVER ASSY 1	1				UR 无光泽黑 金属黑色车用 UR MBL2 FOR SMX
	2SB-W471K-00-P1	尾罩总成 1 TAIL COVER ASSY 1	1				UR 金属红色 7 车用 UR FOR RM7
	2SB-W471K-00-P2	尾罩总成 1 TAIL COVER ASSY 1	1				UR 浅蓝鸡尾白色 1 车用 UR FOR BWC1
	2SB-W471K-00-P3	尾罩总成 1 TAIL COVER ASSY 1	1				UR 浅紫灰黑色车用 UR FOR DNPM1
7	90119-068B7	带垫螺栓 BOLT, WITH WASHER	1				
8	90269-06008	铆钉 RIVET	1				
9	97702-50016	自攻螺钉 SCREW, TAPPING	1				
10	2SB-W472K-00-P0	尾罩总成 2 TAIL COVER ASSY 2	1				UR 无光泽黑 金属黑色车用 UR MBL2 FOR SMX
	2SB-W472K-00-P1	尾罩总成 2 TAIL COVER ASSY 2	1				UR 金属红色 7 车用 UR FOR RM7
	2SB-W472K-00-P2	尾罩总成 2 TAIL COVER ASSY 2	1				UR 浅蓝鸡尾白色 1 车用 UR FOR BWC1
	2SB-W472K-00-P3	尾罩总成 2 TAIL COVER ASSY 2	1				UR 浅紫灰黑色车用 UR FOR DNPM1
11	90119-068B7	带垫螺栓 BOLT, WITH WASHER	1				
12	90269-06008	铆钉 RIVET	1				
13	97702-50016	自攻螺钉 SCREW, TAPPING	1				
14	2SB-F172X-00	尾灯罩 COVER, TAILLIGHT	1				
15	95822-06016	凸缘螺栓 BOLT, FLANGE	2				
16	90387-07818	轴套 COLLAR	2				
17	90183-05807	弹性螺母 NUT, SPRING	2				
18	2SB-F474A-00-P0	辅助握柄 ASSIST, GRIP	1				无光泽黑 MBL2
19	2SB-F474W-00-P0	辅助握柄 2 ASSIST, GRIP 2	1				无光泽黑 MBL2
20	95812-08020	凸缘螺栓 BOLT, FLANGE	4				

FIG. 23 前轮

FRONT WHEEL

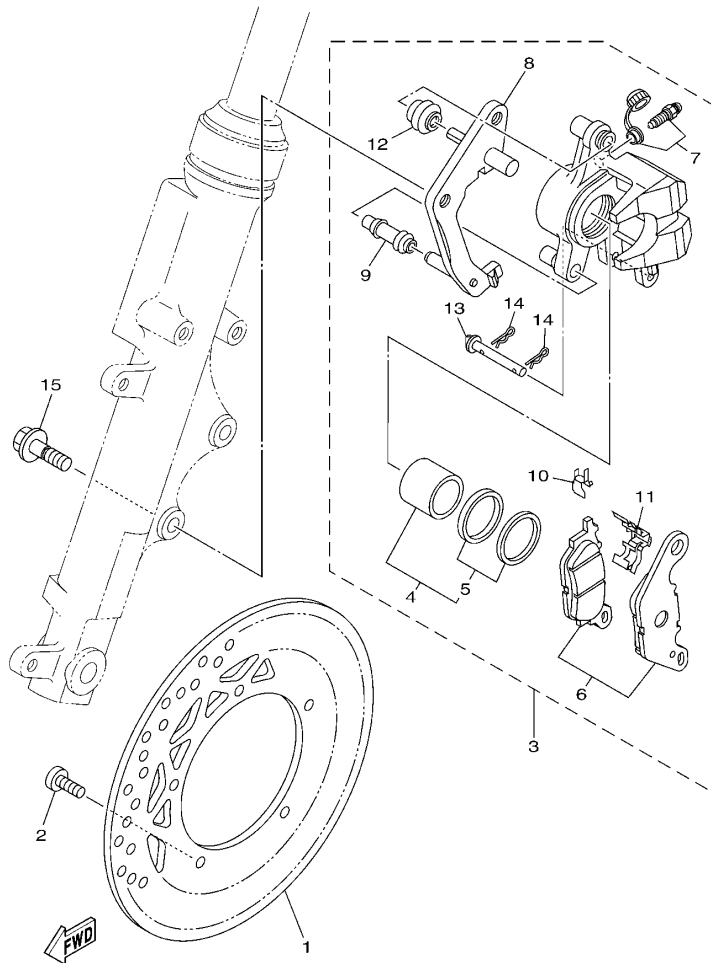


参照 号码	零件号码 PART NO.	零件名称 DESCRIPTION	2SB1				备注 REMARKS
1	3D9-F5168-10-33	前压铸轮 CAST WHEEL, FRONT	1				雅马哈黑色 YB
2	90560-15293	衬套 SPACER	1				
3	93306-202Y4	轴承 BEARING	2				
4	93102-20857	油封 OIL SEAL	2				
5	94127-18828	轮胎 (2.75-18) TIRE (2.75-18 C901 4PR 42P TL)	1				轮胎 CHENG SHIN
6	93900-00826	气门嘴 VALVE, RIM	1				
7	2SB-F511X-00	定位套 COLLAR	1				
8	2MP-F511X-00	定位套 COLLAR	1				
9	5VL-F5181-11	前轮轮轴 AXLE, WHEEL	1				
10	95602-14200	自锁螺母 NUT, SELF-LOCKING	1				

  
2SB1415-P230

FIG. 24 前制动器卡钳

FRONT BRAKE CALIPER



2MP1415-N290

参照 号码	零件号码 PART NO.	零件名称 DESCRIPTION	2SB1				备注 REMARKS
1	3D9-F582U-00	制动盘 (右边) DISK, BRAKE (RIGHT)	1				
2	90111-08805	六角螺栓 BOLT, HEX. SOCKET BUTTON	5				
3	2MP-F580U-00	制动器卡钳组合 (右边) CALIPER ASSY (RIGHT)	1				
4	2MP-W0057-00	卡钳活塞组合 PISTON ASSY, CALIPER	1				
5	2MP-W0047-00	卡钳密封套件 CALIPER SEAL KIT	1				
6	2MP-W0045-00	刹车片组合 BRAKE PAD KIT	1				
7	4S5-W0048-01	带孔螺钉套件 BLEED SCREW KIT	1				
8	4S5-F5921-01	固定架 BRACKET, SUPPORT	1				
9	4S5-F5937-00	衬套 BOOT 2	1				
10	4S5-F5939-00	扣片 CLIP, PAD	1				
11	4S5-F5919-00	减震 SUPPORT, PAD	1				
12	4S5-F5917-00	防尘套 BOOT, CALIPER	1				
13	4S5-F5924-01	刹车片销 PIN, PAD	1				
14	4S5-F5925-00	卡环 CLIP	2				
15	90105-10831	凸缘螺栓 BOLT, FLANGE	2				

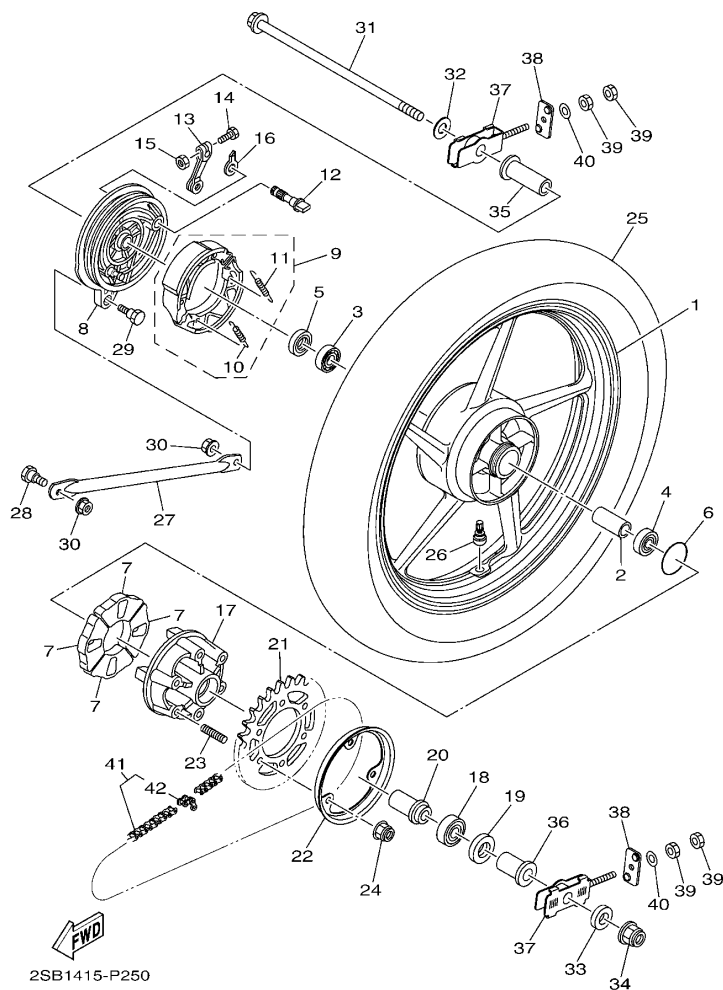


FIG. 25 后轮

REAR WHEEL

参照 号码	零件号码 PART NO.	零件名称 DESCRIPTION	2SB1				备注 REMARKS
1	2SB-F5338-00-33	后压铸轮 CAST WHEEL, REAR	1				雅马哈黑色 YB
2	90387-15809	轴套 COLLAR	1				
3	93306-252YY	轴承 BEARING	1				
4	93306-252XA	轴承 BEARING	1				
5	93104-22802	油封 OIL SEAL	1				
6	93210-42803	O型环 O-RING	1				
7	2SB-F5364-00	减震垫 DAMPER	4				
8	5VL-F5321-01-33	后制动盖 PLATE, BRAKE SHOE	1				雅马哈黑色 YB
9	5VL-W2533-21	制动蹄块总成 BRAKE SHOE SET	1				
10	90506-12801	拉簧 .SPRING, TENSION	1				
11	90506-15802	拉簧 .SPRING, TENSION	1				
12	4GU-F5351-02	凸轮轴 CAMSHAFT	1				
13	5VL-F5355-01	制动臂 LEVER, CAMSHAFT	1				
14	90101-06848	螺栓 BOLT	1				
15	95302-06600	螺母 NUT, HEXAGON	1				
16	4GU-F533A-01	指示片 PLATE, INDICATOR	1				
17	2SB-F5366-00	轮毂离合器 CLUTCH, HUB	1				
18	93306-054X3	轴承 BEARING	1				
19	93106-26812	油封 OIL SEAL	1				
20	2SB-F5377-00	轴套 COLLAR, WHEEL	1				
21	2SB-F5441-00	从动链 SPROCKET, DRIVEN (41T)	1				
22	2SB-F5689-00	导向面板 PLATE, GUIDE	1				
23	90116-08844	双头螺栓 BOLT, STUD	6				
24	95602-08200	自锁螺母 NUT, SELF-LOCKING	6				
25	94110-18803	轮胎 TIRE (100/80 C905 59P TL)	1				CHENG SHIN
26	93900-00826	气门嘴 VALVE, RIM	1				
27	2SB-F5371-00	拉杆 BAR, TENSION	1				

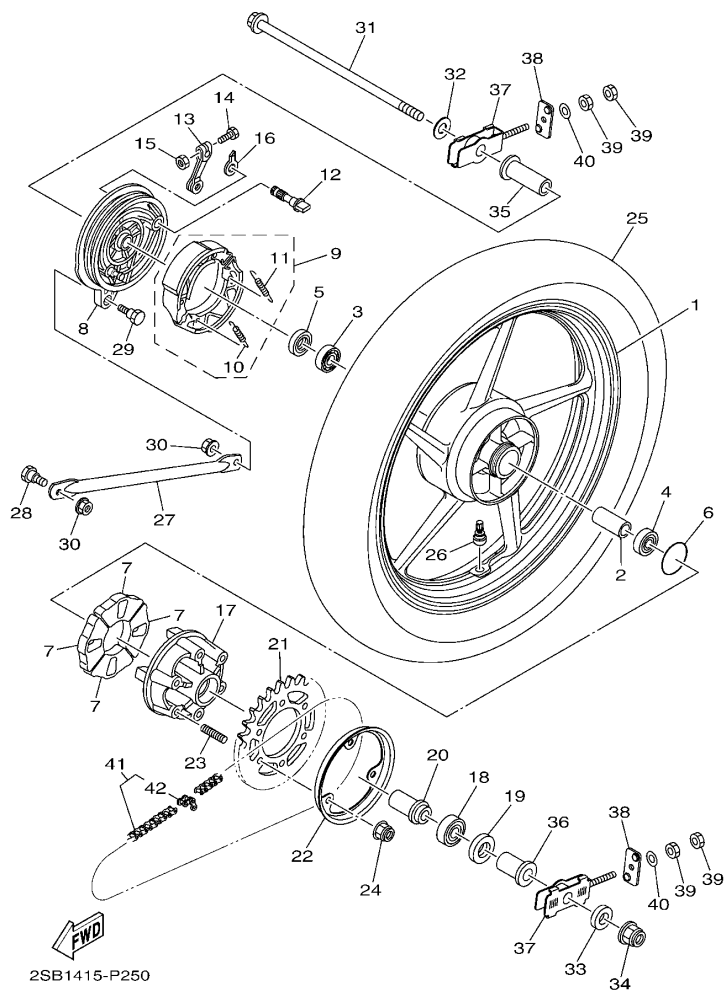


FIG. 25 后轮

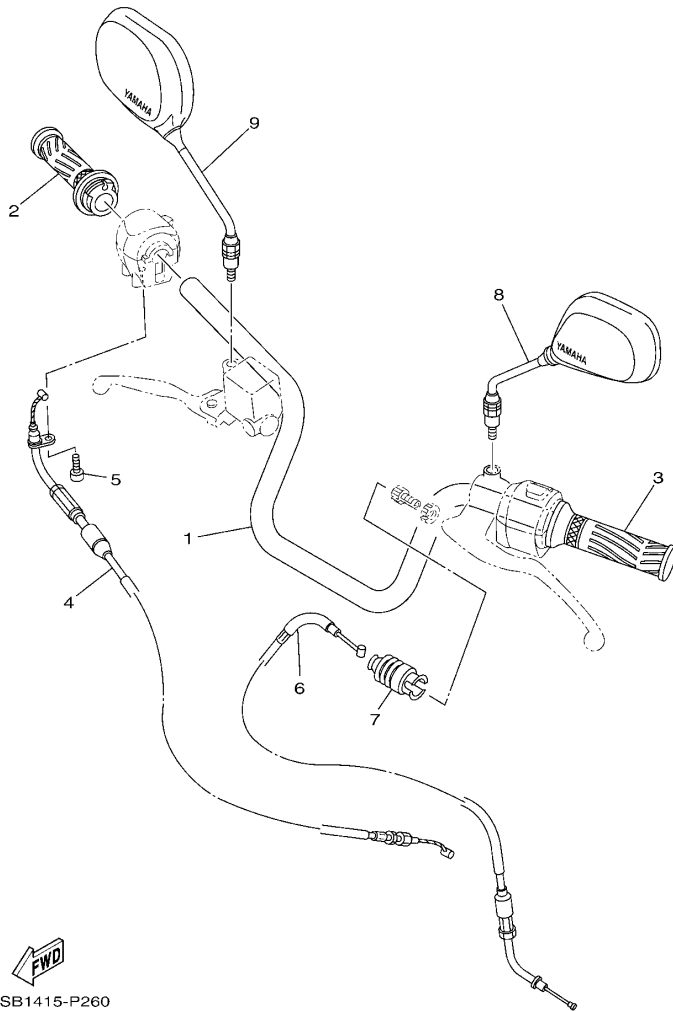
REAR WHEEL

参照 号码	零件号码 PART NO.	零件名称 DESCRIPTION	2SB1				备注 REMARKS
28	90109-08847	螺栓 BOLT	1				
29	90109-08848	螺栓 BOLT	1				
30	95602-08200	自锁螺母 NUT, SELF-LOCKING	2				
31	2SB-F5381-00	后轮轮轴 AXLE, WHEEL	1				
32	90201-15026	平垫圈 WASHER, PLATE	1				
33	90201-14814	平垫圈 WASHER, PLATE	1				
34	95602-14200	自锁螺母 NUT, SELF-LOCKING	1				
35	2SB-F5383-00	轴套 COLLAR, WHEEL	1				
36	2SB-F5386-00	链轮轴套 COLLAR, SPROCKET AXLE	1				
37	2SB-F5389-00	链条张紧板 2 PULLER, CHAIN 2	2				
38	2SB-F539F-00	面板 1 PLATE 1	2				
39	95302-06600	螺母 NUT, HEXAGON	4				
40	92902-06200	垫圈 WASHER	2				
41	2SB-F53C0-00	链条总成 CHAIN (DID 428H 126L)	1				
42	94668-E2001	链条接头 .JOINT, CHAIN (DID 428H)	1				



FIG. 26 操纵手柄·钢索

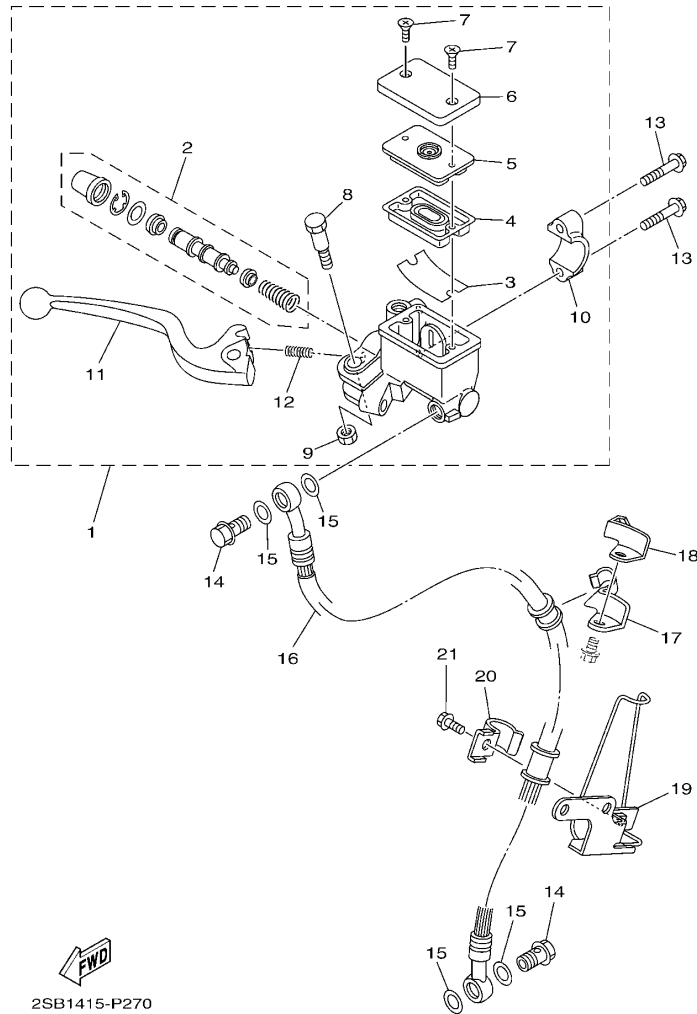
STEERING HANDLE & CABLE



参照 号码	零件号码 PART NO.	零件名称 DESCRIPTION	2SB1				备注 REMARKS
1	2SB-F6111-00	手把 HANDLEBAR	1				
2	2SB-F6240-00	握把 (右边) GRIP ASSY	1				
3	5VL-F6241-00	握把 (左边) GRIP	1				
4	2SB-F6311-00	节气门拉索 1 CABLE, THROTTLE 1	1				
5	98502-05014	十字螺钉 SCREW, PAN HEAD	1				
6	2SB-F6335-00	离合器拉索 CABLE, CLUTCH	1				
7	12B-F6342-00	橡胶套 BOOT, CABLE	1				
8	13R-F6280-00	后视镜组合 (左边) REAR VIEW MIRROR ASSY (LEFT)	1				
9	13R-F6290-00	后视镜组合 (右边) REAR VIEW MIRROR ASSY (RIGHT)	1				

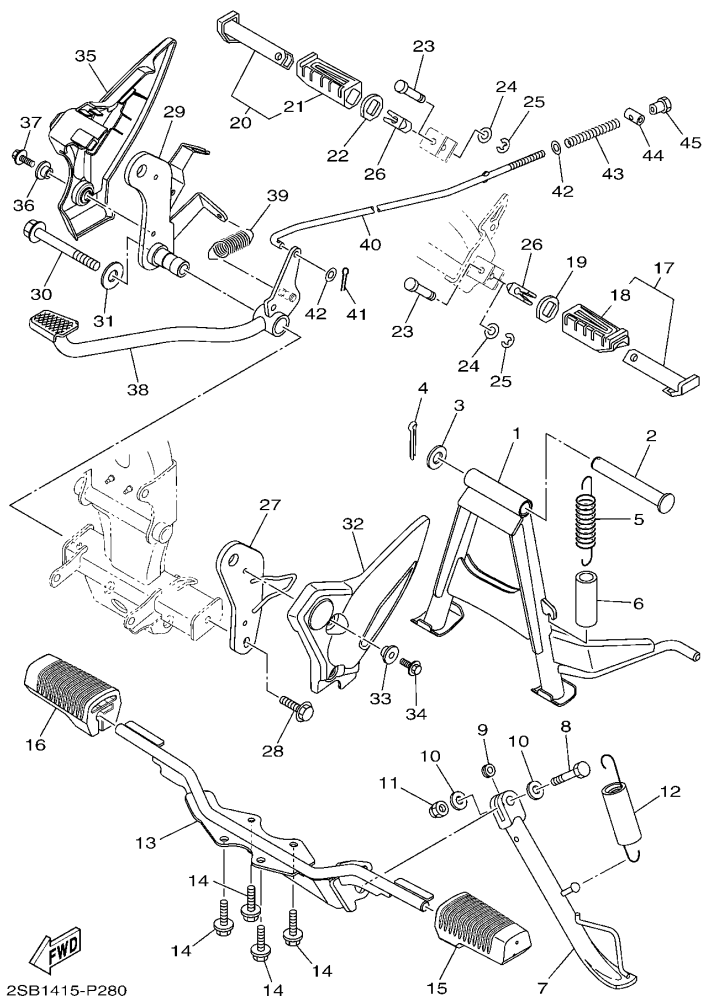
FRONT MASTER CYLINDER

FIG. 27 前主缸



  
2SB1415-P270

参照 号码	零件号码 PART NO.	零件名称 DESCRIPTION	2SB1				备注 REMARKS
1	2SB-F583T-00	前主缸组合 MASTER CYLINDER ASSY	1				
2	2MP-W0041-00	.前主缸套件 .CYLINDER KIT, MASTER	1				
3	4KL-F5896-00	.储油箱面板 .PLATE, RESERVOIR	1				
4	4KL-F5854-00	.油箱隔膜 .DIAPHRAGM, RESERVOIR	1				
5	4KL-F585B-00	.隔板 .PLATE, DIAPHRAGM	1				
6	2MP-F5852-00	.油杯盖 .CAP, RESERVOIR	1				
7	2MP-F589H-00	.螺钉 .SCREW	2				
8	3D9-F589F-01	.手柄螺栓 .BOLT, LEVER	1				
9	3D9-F586F-01	.手柄螺帽 .NUT, U	1				
10	5VL-F5867-00	.主缸托架 .BRACKET, MASTER CYLINDER	1				
11	3D9-H3922-02	.手柄 2 .LEVER 2	1				
12	3D9-F5865-01	.手柄弹簧 .SPRING, LEVER	1				
13	95022-06025	凸缘螺栓 BOLT, FLANGE	2				
14	90401-10811	螺栓 BOLT, UNION	2				
15	90201-108J9	平垫圈 WASHER, PLATE	4				
16	2SB-F5872-00	制动软管 1 HOSE, BRAKE 1	1				
17	5VL-F5887-00	制动软管支架 HOLDER, BRAKE HOSE	1				
18	5VL-F5886-00	制动软管支架 HOLDER, BRAKE HOSE	1				
19	5VL-F5875-01	制动软管支架 1 HOLDER, BRAKE HOSE 1	1				
20	5VL-F5876-00	制动软管支架 2 HOLDER, BRAKE HOSE 2	1				
21	95022-06016	凸缘螺栓 BOLT, FLANGE	1				



2SB1415-P280

FIG. 28 搁脚·支架

STAND & FOOTREST

参照 号码	零件号码 PART NO.	零件名称 DESCRIPTION	2SB1				备注 REMARKS
1	2SB-F7111-00	主支承 STAND, MAIN	1				
2	2SB-F7112-00	主支承轴 SHAFT, MAIN STAND	1				
3	90201-16813	平垫圈 WASHER, PLATE	1				
4	91402-30030	开口销 PIN, COTTER	1				
5	2SB-F7116-00	主支承弹簧 SPRING, MAIN STAND	1				
6	2SB-F247A-00	软管 1 HOSE 1	1				
7	2SB-F7311-00	侧支承 STAND, SIDE	1				
8	90101-10818	螺栓 BOLT	1				
9	1P6-F7313-01	轴套 COLLAR	1				
10	90201-10831	平垫圈 WASHER, PLATE	2				
11	90185-10807	自锁螺母 NUT, SELF-LOCKING	1				
12	2SB-F7316-00	侧支承弹簧 SPRING, SIDE STAND	1				
13	2SB-F7411-00	搁脚板 1 FOOTREST 1	1				
14	95822-08016	凸缘螺栓 BOLT, FLANGE	4				
15	2SB-F7413-00	搁脚套 COVER, FOOTREST	1				
16	2SB-F7423-00	搁脚套 COVER, FOOTREST	1				
17	5VL-F7430-01	后搁脚总成 1 REAR FOOTREST ASSY 1	1				
18	5VL-F7433-00	后搁脚板套 COVER, REAR FOOTREST	1				
19	5VL-F7445-01	面板 1 PLATE 1	1				
20	5VL-F7440-01	后搁脚总成 2 REAR FOOTREST ASSY 2	1				
21	5VL-F7444-00	后搁脚板套 COVER, REAR FOOTREST	1				
22	5VL-F7445-01	面板 1 PLATE 1	1				
23	90249-06800	销 PIN	2				
24	92902-06200	垫圈 WASHER	2				
25	99002-05600	卡环 CLIP	2				
26	5VL-F7414-00	搁脚板减震 DAMPER, FOOTREST	2				
27	2SB-F2191-00	左构件 MBR., LH.	1				

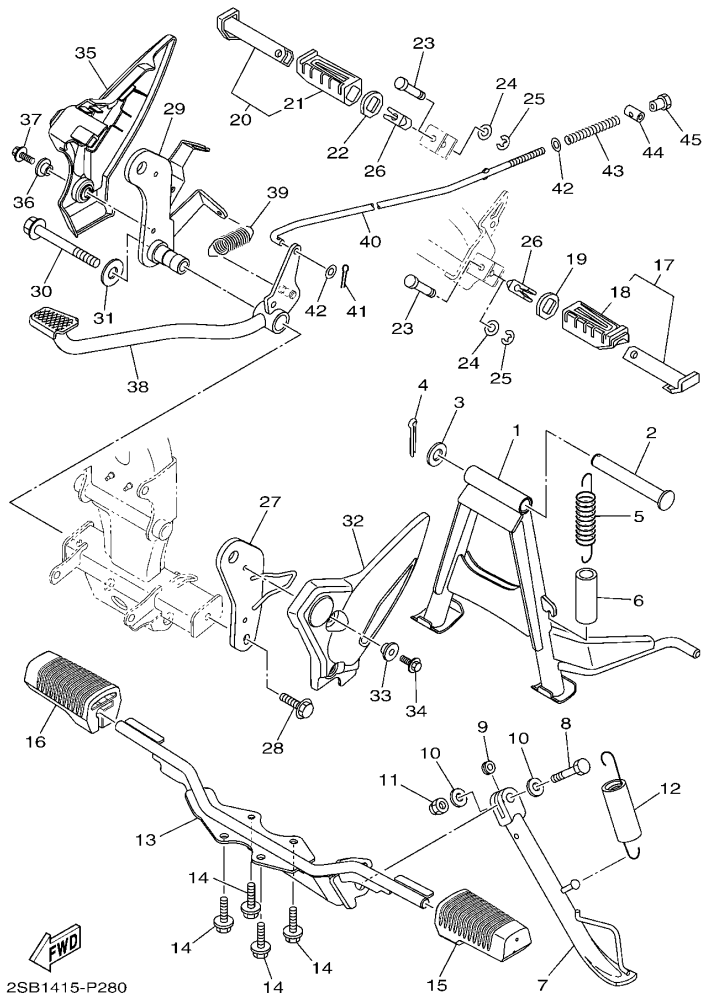


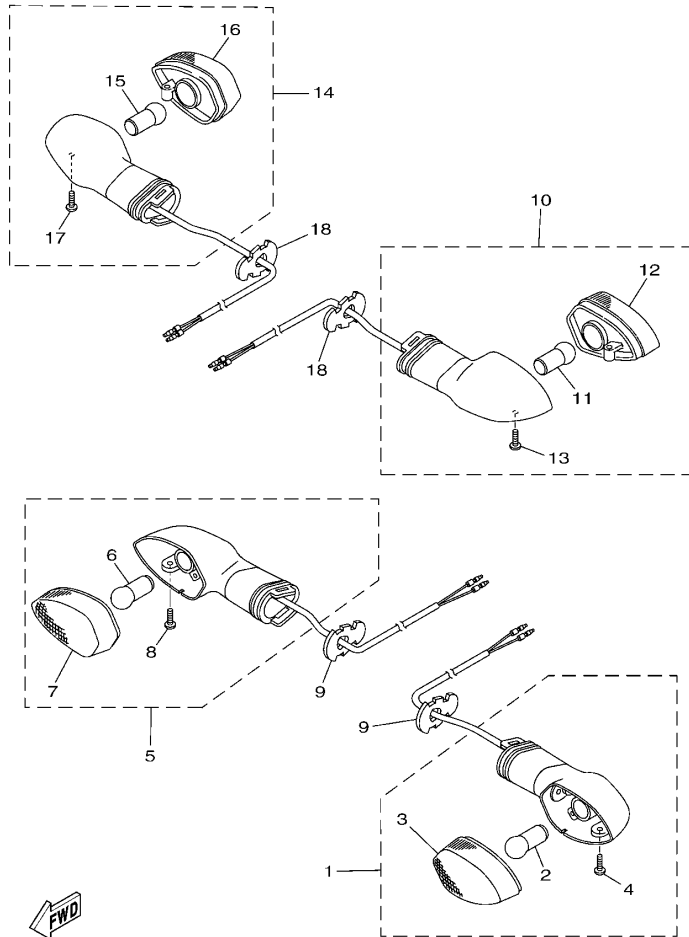
FIG. 28 搁脚·支架

STAND & FOOTREST

参照 号码	零件号码 PART NO.	零件名称 DESCRIPTION	2SB1				备注 REMARKS
28	95812-08020	凸缘螺栓 BOLT, FLANGE	1				
29	2SB-F2192-00	右构件 MBR.,RH.	1				
30	95812-08065	凸缘螺栓 BOLT, FLANGE	1				
31	90201-08840	平垫圈 WASHER, PLATE	1				
32	2SB-F7486-00	盖 1 COVER 1	1				
33	90387-07818	轴套 COLLAR	2				
34	95802-06012	凸缘螺栓 BOLT, FLANGE	2				
35	2SB-F7487-00	盖 2 COVER 2	1				
36	90387-07818	轴套 COLLAR	2				
37	95802-06012	凸缘螺栓 BOLT, FLANGE	2				
38	2SB-F7211-00	制动踏板 PEDAL, BRAKE	1				
39	90506-26809	拉簧 SPRING, TENSION	1				
40	2SB-F7231-00	制动拉杆 ROD, BRAKE	1				
41	91402-20012	开口销 PIN, COTTER	1				
42	92902-06200	垫圈 WASHER	2				
43	90501-10806	压簧 SPRING, COMPRESSION	1				
44	90249-12808	销 PIN	1				
45	90179-06826	螺母 NUT	1				







2SB1415-P310

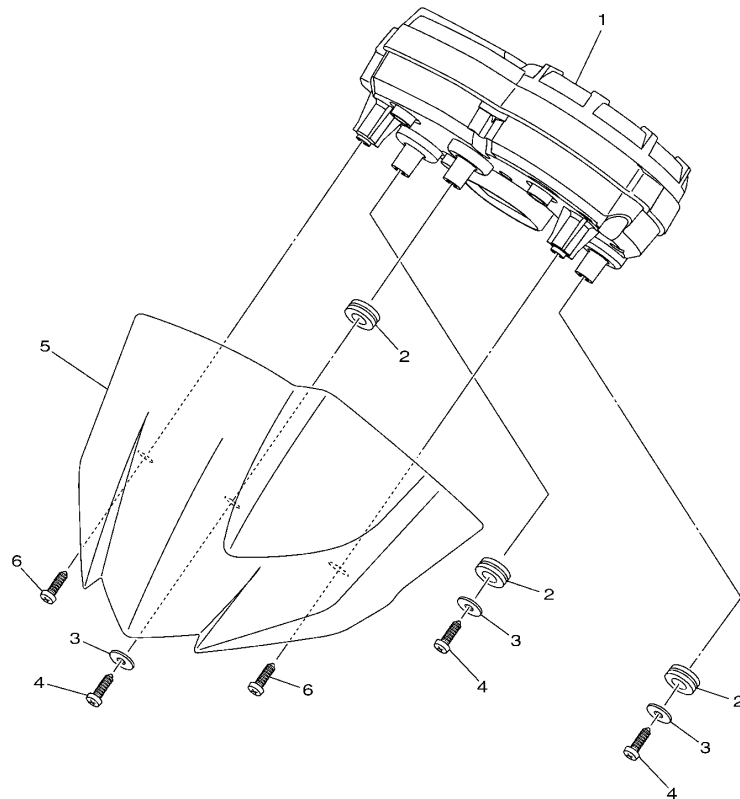
FIG. 31 转向灯

FLASHER LIGHT

参照 号码	零件号码 PART NO.	零件名称 DESCRIPTION	2SB1				备注 REMARKS
1	2SB-H3310-00	前转向灯组合 1 FRONT FLASHER LIGHT ASSY 1	1				
2	44C-H3311-10	.转向灯灯泡 .BULB (12V-10W)	1				
3	44C-H333A-00	.透镜组件 1 .LENS COMP 1	1				
4	3D9-H3333-10	.镜面安装螺钉 .SCREW, LENS FITTING	1				
5	2SB-H3320-00	前转向灯组合 2 FRONT FLASHER LIGHT ASSY 2	1				
6	44C-H3311-10	.转向灯灯泡 .BULB (12V-10W)	1				
7	44C-H334A-00	.透镜组件 2 .LENS COMP 2	1				
8	3D9-H3333-10	.镜面安装螺钉 .SCREW, LENS FITTING	1				
9	3D9-H3318-10	转向灯支承 1 STAY, FLASHER 1	2				
10	2SB-H3330-00	后转向灯组合 1 REAR FLASHER LIGHT ASSY 1	1				
11	44C-H3311-10	.转向灯灯泡 .BULB (12V-10W)	1				
12	44C-H334A-00	.透镜组件 2 .LENS COMP 2	1				
13	3D9-H3333-10	.镜面安装螺钉 .SCREW, LENS FITTING	1				
14	2SB-H3340-00	后转向灯组合 2 REAR FLASHER LIGHT ASSY 2	1				
15	44C-H3311-10	.转向灯灯泡 .BULB (12V-10W)	1				
16	44C-H333A-00	.透镜组件 1 .LENS COMP 1	1				
17	3D9-H3333-10	.镜面安装螺钉 .SCREW, LENS FITTING	1				
18	3D9-H3318-10	转向灯支承 1 STAY, FLASHER 1	2				

FIG. 32 仪表

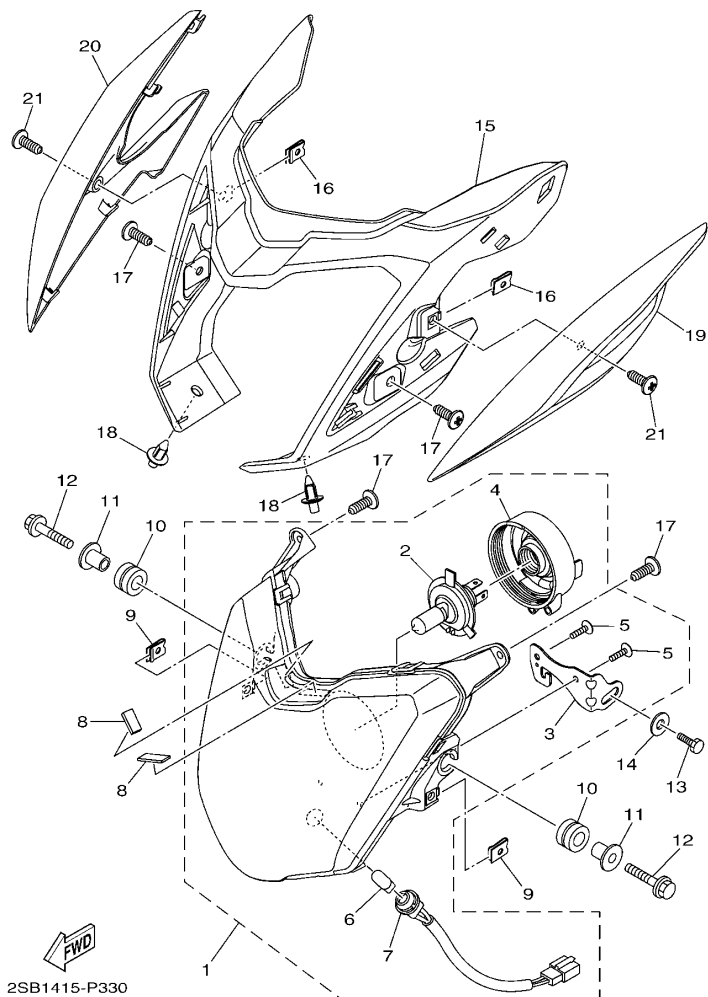
METER



参照 号码	零件号码 PART NO.	零件名称 DESCRIPTION	2SB1				备注 REMARKS
1	2SB-H3500-00	仪表组合 METER ASSY	1				
2	90480-14812	橡胶垫 GROMMET	3				
3	90201-05827	平垫圈 WASHER, PLATE	3				
4	97702-50016	自攻螺钉 SCREW, TAPPING	3				
5	2SB-H3559-00-P0	仪表盖 COVER, METER	1				UR 金属黑色车用 UR FOR SMX
	2SB-H3559-00-P1	仪表盖 COVER, METER	1				UR 金属红色 7 车用 UR FOR RM7
	2SB-H3559-00-P2	仪表盖 COVER, METER	1				UR 浅蓝鸡尾白色 1 车用 UR FOR BWC1
	2SB-H3559-00-P3	仪表盖 COVER, METER	1				UR 浅紫灰黑色车用 UR FOR DNPM1
6	97702-50016	自攻螺钉 SCREW, TAPPING	2				

  
2SB1415-P320





2SB1415-P330

FIG. 33 前大灯

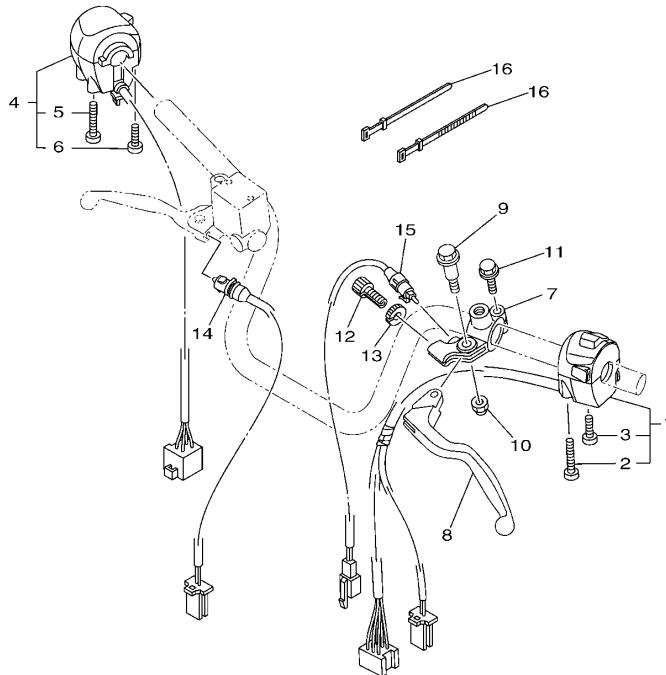
HEADLIGHT

参照 号码	零件号码 PART NO.	零件名称 DESCRIPTION	2SB1				备注 REMARKS
1	2SB-H4300-00	前照灯组合 HEADLIGHT ASSY	1				
2	1SB-H4314-00	.前照灯灯泡 .BULB, HEADLIGHT (12V-35/35W)	1				
3	2SB-H4318-00	.前照灯支承 1 .STAY, HEADLIGHT 1	1				
4	1SB-H4397-00	.灯座盖 .COVER, SOCKET	1				
5	2SL-H4192-00	.特制螺钉 .SCREW, SPECIAL	2				
6	1JD-H4347-00	.灯泡 .BULB (W3W-12V)	1				
7	2SB-H4312-00	.导线组合 .CORD ASSY	1				
8	90520-02830	面板减震器 DAMPER, PLATE	2				
9	90183-05807	弹性螺母 NUT, SPRING	2				
10	90480-14102	橡胶垫 GROMMET	2				
11	90387-06158	轴套 COLLAR	2				
12	95822-06020	凸缘螺栓 BOLT, FLANGE	2				
13	97002-06012	螺栓 BOLT	1				
14	90201-06850	平垫圈 WASHER, PLATE	1				
15	2SB-F3121-00	上盖 1 COVER, UPPER 1	1				
16	90183-05807	弹性螺母 NUT, SPRING	2				
17	97702-50016	自攻螺钉 SCREW, TAPPING	4				
18	90269-06008	铆钉 RIVET	2				
19	2SB-F3122-00-P0	外盖 1 COVER, OUTER 1	1				UR 无光泽黑 金属黑色车用 UR MBL2 FOR SMX
	2SB-F3122-00-P1	外盖 1 COVER, OUTER 1	1				UR 金属红色 7 车用 UR FOR RM7
	2SB-F3122-00-P2	外盖 1 COVER, OUTER 1	1				UR 浅蓝鸡尾白色 1 车用 UR FOR BWC1
	2SB-F3122-00-P3	外盖 1 COVER, OUTER 1	1				UR 浅紫灰黑色车用 UR FOR DNPM1
20	2SB-F3132-00-P0	外盖 2 COVER, OUTER 2	1				UR 无光泽黑 金属黑色车用 UR MBL2 FOR SMX
	2SB-F3132-00-P1	外盖 2 COVER, OUTER 2	1				UR 金属红色 7 车用 UR FOR RM7
	2SB-F3132-00-P2	外盖 2 COVER, OUTER 2	1				UR 浅蓝鸡尾白色 1 车用 UR FOR BWC1
	2SB-F3132-00-P3	外盖 2 COVER, OUTER 2	1				UR 浅紫灰黑色车用 UR FOR DNPM1
21	97702-50016	自攻螺钉 SCREW, TAPPING	2				



FIG. 35 手柄开关·杆

HANDLE SWITCH & LEVER



参照 号码	零件号码 PART NO.	零件名称 DESCRIPTION	2SB1				备注 REMARKS
1	2SB-H3972-00	手把开关 4 SWITCH, HANDLE 4	1				
2	98507-05042	. 十字螺钉 .SCREW, PAN HEAD	1				
3	98507-05022	. 十字螺钉 .SCREW, PAN HEAD	1				
4	2SB-H3975-00	手把开关 2 SWITCH, HANDLE 2	1				
5	98507-05050	. 十字螺钉 .SCREW, PAN HEAD	1				
6	98507-05030	. 十字螺钉 .SCREW, PAN HEAD	1				
7	4FP-H2911-00	手柄座 1 HOLDER, LEVER 1	1				
8	3D9-H3912-30	手柄 1 LEVER 1	1				
9	90109-06850	螺栓 BOLT	1				
10	95602-06100	锁紧螺母 NUT, U	1				
11	97590-06522	带垫螺栓 BOLT, WITH WASHER	1				
12	90123-08813	螺栓 BOLT	1				
13	90179-08862	螺母 NUT	1				
14	2SB-H3980-00	前制动开关组合 FRONT STOP SWITCH ASSY	1				
15	2SB-H2917-00	开关 SWITCH	1				
16	4TU-H3936-00	开关导线撞带 BAND, SWITCH CORD	2				



2SB1415-P350

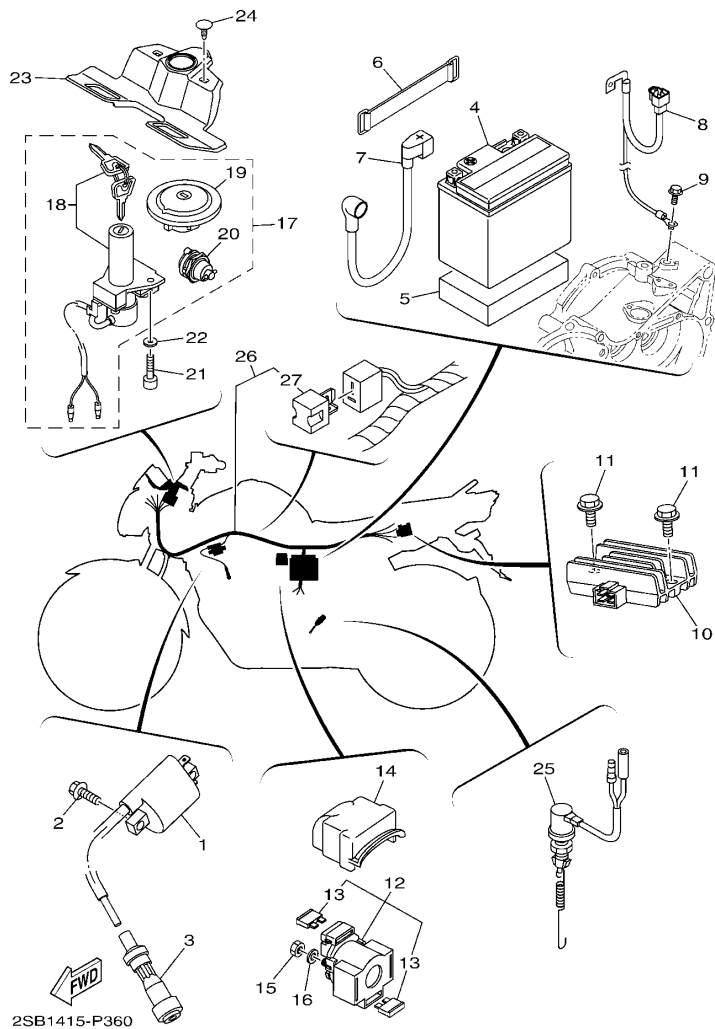


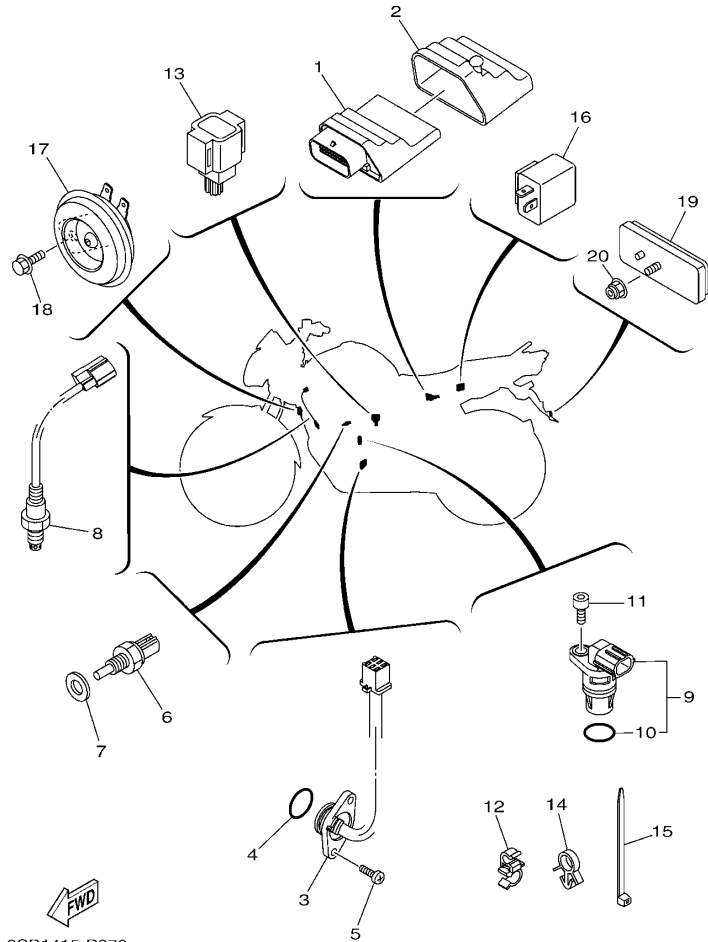
FIG. 36 电气系统 1

ELECTRICAL 1

参照 号码	零件号码 PART NO.	零件名称 DESCRIPTION	2SB1				备注 REMARKS
1	2SB-H2310-00	点火线圈组合 IGNITION COIL ASSY	1				
2	95022-06020	凸缘螺栓 BOLT, FLANGE	2				
3	2SB-H2370-00	火花塞帽组合 PLUG CAP ASSY	1				
4	5WY-H2100-10	蓄电池组合 (YTX5L-BS) BATTERY ASSY (YTX5L-BS)	1				
5	90520-25801	面板减震器 DAMPER, PLATE	1				
6	5VL-H2131-01	蓄电池带箍 BAND, BATTERY	1				
7	2SB-H2115-00	正极导线 WIRE, PLUS LEAD	1				
8	2SB-H2116-00	负极导线 WIRE, MINUS LEAD	1				
9	95802-06010	凸缘螺栓 BOLT, FLANGE	1				
10	54B-H1960-00	整流调节器 RECTIFIER & REGULATOR ASSY	1				
11	95802-06020	凸缘螺栓 BOLT, FLANGE	2				
12	5VL-H1940-10	起动继电器组合 STARTER RELAY ASSY	1				
13	4FP-H2151-00	保险丝 . FUSE (15A)	2				
14	2SB-F172W-00	盖 COVER	1				
15	95302-06600	螺母 NUT, HEXAGON	2				
16	90201-068C2	平垫圈 WASHER, PLATE	2				
17	2SB-H2021-00	锁总成 KEY SET	1				
18	2MP-H2501-00	主开关方向锁组合 . MAIN SWITCH STEERING LOCK	1				
19	1BK-F4610-10	油箱盖总成 . CAP ASSY	1				
20	5VL-F1780-01	侧盖锁 . LOCK ASSY	1				
21	91312-06020	螺栓 BOLT	2				
22	90201-068C2	平垫圈 WASHER, PLATE	2				
23	2SB-H2568-00	主开关盖 COVER, MAIN SWITCH	1				
24	90269-07013	铆钉 RIVET	2				
25	2SB-H2530-00	制动开关总成 STOP SWITCH ASSY	1				
26	2SB-H2590-00	电缆总成 WIRE HARNESS ASSY	1				
27	5VL-H1980-10	二极管总成 . DIODE ASSY	1				

FIG. 37 电气系统 2

ELECTRICAL 2



2SB1415-P370

参照 号码	零件号码 PART NO.	零件名称 DESCRIPTION	2SB1				备注 REMARKS
1	2SB-H591A-00	发动机控制装置组合 ENGINE CONTROL UNIT ASSY	1				
2	2SB-H5546-00	箍带 BAND	1				
3	2SB-H2540-00	空挡开关组合 NEUTRAL SWITCH ASSY	1				
4	93210-23801	O型环 O-RING	1				
5	98502-05016	十字螺钉 SCREW, PAN HEAD	2				
6	2SB-H3591-00	温控器组 THERMO UNIT	1				
7	90201-10128	平垫圈 WASHER, PLATE	1				
8	2DP-H592A-00	氧气传感器 SENSOR, OXYGEN	1				
9	2SB-H3755-00	速度传感器 SENSOR, SPEED	1				
10	2SB-H1168-00	.0型 .O-RING	1				
11	91312-06016	螺栓 BOLT	1				
12	90464-09018	线夹 CLAMP	1				
13	1PA-H2576-00	紧急制动开关组合 SENSOR, LEAN ANGLE	1				
14	90464-15157	线夹 CLAMP	2				
15	90464-35820	线夹 CLAMP	2				
16	18C-H3350-01	闪烁继电器组合 FLASHER RELAY ASSY	1				
17	2SB-H3371-00	电喇叭 HORN	1				
18	95802-06012	凸缘螺栓 BOLT, FLANGE	1				
19	4FP-H5130-21	后反射镜组合 REAR REFLECTOR ASSY	1				
20	95702-05500	螺母 NUT, FLANGE	1				

零件号码索引  
NUMERICAL INDEX

零件号码 PART NO.	参照 号码	零件号码 PART NO.	参照 号码	零件号码 PART NO.	参照 号码	零件号码 PART NO.	参照 号码	零件号码 PART NO.	参照 号码	零件号码 PART NO.	参照 号码
1ST-14104-00	6 - 15	2SB-E3595-00	6 - 1	2SB-E6356-00	11 - 15	2SB-F1778-00	17 - 3	5LK-F3356-01	20 - 10	5VL-F5355-01	25 - 13
1ST-1410H-00	6 - 14	2SB-E3635-00	6 - 9	2SB-E6357-00	11 - 23		17 - 8	2SB-F5364-00	20 - 26	2SB-F5364-00	25 - 7
1ST-1416A-00	6 - 17	2SB-E3750-00	6 - 12	4FP-E6358-00	11 - 14	2SB-F177G-00	17 - 11	2SB-F5366-00	19 - 17	2SB-F5366-00	25 - 17
1ST-14216-00	6 - 13	2GS-E3770-00	6 - 5	2SB-E6371-00	11 - 8	5VL-F1780-01	36 - 20	4FP-F3411-00	19 - 2	2SB-F5371-00	25 - 27
1ST-14945-00	6 - 16	2SB-E3907-00	21 - 26	2SB-E6380-00	11 - 21	2SB-F2110-00	18 - 1	4FP-F3411-10	20 - 34	2SB-F5377-00	25 - 20
2SB-E1111-00	1 - 1	2SB-E3971-00	21 - 30	2SB-E7121-00	12 - 7	2SB-F2141-00	18 - 3	1KL-F3412-00	19 - 1	2SB-F5381-00	25 - 31
2SB-E111F-00	4 - 6	5CA-E4147-00	6 - 6	2SB-E7131-00	12 - 5	2SB-F2151-00	18 - 6	4FP-F3412-00	19 - 3	2SB-F5383-00	25 - 35
2SB-E1166-00	6 - 30	2SB-E4410-00	6 - 18	2SB-E7141-00	12 - 2	2SB-F2191-00	28 - 27	4GU-F3416-00	19 - 5	2SB-F5386-00	25 - 36
2SB-E1181-00	1 - 14	2SB-E4411-00	6 - 19	2SB-E7151-00	12 - 6	2SB-F2192-00	28 - 29	5VL-F3418-01	19 - 8	2SB-F5389-00	25 - 37
2SB-E1186-00	1 - 8	2SB-E4412-00	6 - 20	2SB-E7211-00	12 - 22	2SB-F2210-01	18 - 10	5VL-F341E-00	19 - 4	2SB-F539F-00	25 - 38
2SB-E1193-00	1 - 6	2SB-E443E-00	6 - 26	2SB-E7221-00	12 - 13	2SB-F247A-00	28 - 6	5AP-F3427-00	20 - 12	2SB-F53C0-00	25 - 41
2SB-E1310-00	1 - 17	2SB-E4450-00	6 - 21	2SB-E7231-00	12 - 17	2SB-F3102-00	20 - 1		20 - 28	2SB-F5441-00	25 - 21
2SB-E1351-00	1 - 18	2SB-E4452-00	6 - 23	2SB-E7241-00	12 - 19	2SB-F3103-00	20 - 17	5VL-F3435-00-33	19 - 10	2SB-F5689-00	25 - 22
2SB-E1454-00	2 - 11	2SB-E4453-00	6 - 22	2SB-E7251-00	12 - 16	5VL-F3106-D0	20 - 2	5VL-F3441-00	19 - 12	2MP-F580U-00	24 - 3
2SB-E1496-00	2 - 13	2SB-E4613-00	7 - 7	2SB-E7258-00	12 - 21	5VL-F3107-D0	20 - 18	4TU-F3479-00	20 - 9	3D9-F582U-00	24 - 1
2SB-E1631-00	2 - 7	2SB-E4710-00	7 - 1	2SB-E7411-00	12 - 1	5HH-F3110-22	20 - 6		20 - 25	2SB-F583T-00	27 - 1
2SB-E1633-00	2 - 8	2SB-E4718-00	7 - 2	2SB-E7421-00	12 - 12		20 - 22	2SB-F411J-00	21 - 14	2MP-F5852-00	27 - 6
2SB-E1651-00	2 - 4	1JD-E4747-00	15 - 12	2SB-E7456-00	12 - 27	1ST-F3111-00	20 - 15		21 - 22	4KL-F5854-00	27 - 4
2SB-E1681-00	2 - 2	2SB-E4799-00	7 - 3	2SB-E7471-00	12 - 10		20 - 31	4S0-F4135-00	21 - 37	4KL-F585B-00	27 - 5
2SB-E2111-00	3 - 1	2SB-E4877-00	6 - 24	2SB-E8101-00	14 - 4	1ST-F3118-00	20 - 13	2SB-F4141-00	21 - 2	3D9-F5865-01	27 - 12
2SB-E2113-00	3 - 5	2SB-E5113-00	9 - 10	2SB-E8110-00	14 - 9		20 - 29	1DB-F414G-01	21 - 28	5VL-F5867-00	27 - 10
2SB-E2117-00	3 - 7	2SB-E5155-00	8 - 3	1KL-E8113-00	14 - 10	2SB-F3121-00	33 - 15	2SB-F4170-10	21 - 31	3D9-F586F-01	27 - 9
1P6-E2118-00	3 - 6	2SB-E5362-00	9 - 20	2SB-E8140-00	14 - 1	2SB-F3122-00-P0	33 - 19	18C-F4180-01	21 - 36	2SB-F5872-00	27 - 16
2SB-E2119-00	3 - 3	2SB-E5377-00	9 - 12	1BK-E8185-00	13 - 3	2SB-F3122-00-P1	33 - 19	2TY-F4181-00	7 - 5	5VL-F5875-01	27 - 19
2SB-E2121-00	3 - 2	2SB-E5411-00	9 - 3	2SB-E8337-00	14 - 3	2SB-F3122-00-P2	33 - 19	4FP-F4181-00	21 - 3	5VL-F5876-00	27 - 20
1JD-E2126-00	3 - 4	2SB-E5418-00	9 - 11	2SB-E8511-00	13 - 8	2SB-F3122-00-P3	33 - 19	2SB-F4182-00	21 - 4	5VL-F5886-00	27 - 18
2SB-E2150-00	3 - 9	2SB-E5421-00	9 - 16	2SB-E8512-00	13 - 9	2SB-F3132-00-P0	33 - 20	2SB-F4186-00	21 - 5	5VL-F5887-00	27 - 17
2SB-E2156-00	3 - 12	2SB-E5441-00	9 - 1	2SB-E8513-00	13 - 10	2SB-F3132-00-P1	33 - 20	2SB-F4188-00	21 - 25	4KL-F5896-00	27 - 3
2SB-E2159-00	3 - 10	2SB-E5451-00	9 - 4	2SB-E8531-00	13 - 11	2SB-F3132-00-P2	33 - 20	2SB-F419E-00	21 - 34	3D9-F589F-01	27 - 8
2SB-E2169-00	3 - 8	2SB-E5461-00	9 - 17	2SB-E8535-00	13 - 12	2SB-F3132-00-P3	33 - 20	2SB-F4216-00	21 - 23	2MP-F589H-00	27 - 7
2SB-E2171-00	4 - 1	2SB-E5514-00	10 - 1	2SB-E8541-00	13 - 1	1ST-F3141-00	20 - 11	2SB-F4312-00	21 - 38	4S5-F5917-00	24 - 12
2SB-E2210-00	4 - 15	2SB-E5521-00	10 - 2	1JD-E8542-00	13 - 6		20 - 27	2SB-F4313-00	21 - 39	4S5-F5919-00	24 - 11
1JD-E2213-00	4 - 16	2SB-E5524-00	10 - 5	2SB-F1110-00	15 - 1	1ST-F3144-00	20 - 3	2SB-F4314-00	21 - 40	4S5-F5921-01	24 - 8
2SB-E2231-00	4 - 11	2SB-E5580-00	10 - 8	2SB-F1316-00	15 - 2		20 - 19	2SB-F4315-00	21 - 41	4S5-F5924-01	24 - 13
2SB-E2241-00	4 - 12	2SB-E5583-00	10 - 9	2SB-F1317-00	15 - 5	1ST-F3145-00	20 - 4	2SB-F4491-00	21 - 27	4S5-F5925-00	24 - 14
2SB-E2280-00	4 - 7	5VL-E5598-00	4 - 13	2SB-F137U-00	21 - 8		20 - 20	1BK-F4610-10	36 - 19	4S5-F5937-00	24 - 9
2SB-E2288-00	4 - 8	2SB-E5614-00	10 - 10	2SB-F137V-00	21 - 16	5AP-F3147-00	20 - 14	2SB-F4730-00	22 - 1	4S5-F5939-00	24 - 10
2SB-E2435-00	1 - 9	2SB-E6111-00	11 - 1	2SB-F1511-00-P0	16 - 1		20 - 30	4TU-F4741-00	22 - 2	2SB-F6111-00	26 - 1
2SB-E2437-00	4 - 18	2SB-E6135-00	11 - 18	2SB-F1511-00-P1	16 - 1	5AP-F3153-00	20 - 5	2SB-F474A-00-P0	22 - 18	2SB-F6240-00	26 - 2
2SB-E2661-00	1 - 19	2SB-E6150-00	11 - 6	2SB-F1511-00-P2	16 - 1		20 - 21	2SB-F474W-00-P0	22 - 19	5VL-F6241-00	26 - 3
2SB-E3300-00	5 - 1	2SB-E6154-00	11 - 7	2SB-F1511-00-P3	16 - 1	1ST-F3170-00	20 - 7	2MP-F511X-00	23 - 8	13R-F6280-00	26 - 8
2D0-E3411-00	5 - 5	2SB-E6300-00	11 - 5	18C-F1513-01	16 - 2		20 - 23	2SB-F511X-00	23 - 7	13R-F6290-00	26 - 9
2SB-E3440-00	5 - 6	2SB-E6321-00	11 - 9	5VL-F1541-00	17 - 15	4GU-F3173-01	20 - 8	3D9-F5168-10-33	23 - 1	2SB-F6311-00	26 - 4
2SB-E3447-00	5 - 7	2SB-E6324-00	11 - 10	2SB-F1611-00	16 - 6		20 - 24	5VL-F5181-11	23 - 9	2SB-F6335-00	26 - 6
1SF-E3455-00	9 - 8	2SB-E6333-00	11 - 12	2SB-F1650-00	18 - 7	2SB-F3174-00	19 - 14	5VL-F5321-01-33	25 - 8	12B-F6342-00	26 - 7
3D9-E3556-01	6 - 7	2SB-E6337-00	11 - 13	2SB-F172W-00	36 - 14	2SB-F317J-00	19 - 16	2SB-F5338-00-33	25 - 1	2SB-F7111-00	28 - 1
18C-E3575-01	6 - 11	2SB-E6345-00	11 - 22	2SB-F172X-00	22 - 14	1ST-F331X-00	20 - 33	4GU-F533A-01	25 - 16	2SB-F7112-00	28 - 2
2SB-E3585-00	6 - 2	2SB-E6351-00	11 - 11	5VL-F1746-00	16 - 3	5VL-F3346-01	20 - 35	4GU-F5351-02	25 - 12	2SB-F7116-00	28 - 5

零件号码索引  
NUMERICAL INDEX

零件号码 PART NO.	参照 号码	零件号码 PART NO.	参照 号码	零件号码 PART NO.	参照 号码	零件号码 PART NO.	参照 号码	零件号码 PART NO.	参照 号码	零件号码 PART NO.	参照 号码
2SB-F7211-00	28 - 38	44C-H3311-10	31 - 2	2DP-H592A-00	37 - 8	90109-08848	25 - 29	90201-12819	18 - 5	90464-15157	37 - 14
2SB-F7214-00	7 - 6		31 - 6	2MP-W0041-00	27 - 2	90110-06304	1 - 16	90201-12820	11 - 3	90464-35820	37 - 15
2SB-F7231-00	28 - 40		31 - 11	2MP-W0045-00	24 - 6	90110-06846	1 - 21	90201-14814	25 - 33	90467-09006	21 - 42
2SB-F7311-00	28 - 7		31 - 15	2MP-W0047-00	24 - 5	90111-05035	5 - 2	90201-15022	2 - 14	90467-12806	6 - 27
1P6-F7313-01	28 - 9	3D9-H3318-10	31 - 9	4SS-W0048-01	24 - 7	90111-06807	7 - 4	90201-15026	25 - 32	90467-12828	6 - 31
2SB-F7316-00	28 - 12		31 - 18	2MP-W0057-00	24 - 4	90111-08805	24 - 2	90201-16813	28 - 3	90467-16807	6 - 32
2SB-F7411-00	28 - 13	2SB-H3320-00	31 - 5	2SB-W1140-00	2 - 1	90116-08844	25 - 23	90201-178D3	12 - 20	90467-20050	6 - 25
2SB-F7413-00	28 - 15	2SB-H3330-00	31 - 10	2SB-W1161-00	2 - 10	90119-06810	6 - 29	90201-22793	12 - 14	90480-12812	9 - 15
5VL-F7414-00	28 - 26	3D9-H3333-10	31 - 4	2SB-W137W-00-P0	21 - 7	90119-068B7	16 - 7	90201-228F6	17 - 10	90480-12835	21 - 10
2SB-F7423-00	28 - 16		31 - 8	2SB-W137W-00-P1	21 - 7		18 - 8	90201-258D7	10 - 7		21 - 18
5VL-F7430-01	28 - 17		31 - 13	2SB-W137W-00-P2	21 - 7		22 - 3	90202-26142	19 - 7	90480-13837	17 - 2
5VL-F7433-00	28 - 18		31 - 17	2SB-W137W-00-P3	21 - 7		22 - 7	90208-20003	11 - 20		17 - 7
5VL-F7440-01	28 - 20	44C-H333A-00	31 - 3	2SB-W137X-00-P0	21 - 15		22 - 11	90209-17285	12 - 3		21 - 12
5VL-F7444-00	28 - 21		31 - 16	2SB-W137X-00-P1	21 - 15	90123-08813	35 - 12	90209-18208	12 - 18		21 - 20
5VL-F7445-01	28 - 19	2SB-H3340-00	31 - 14	2SB-W137X-00-P2	21 - 15	90149-06829	4 - 14	90214-10006	2 - 15	90480-14102	33 - 10
	28 - 22	44C-H334A-00	31 - 7	2SB-W137X-00-P3	21 - 15	90151-06818	13 - 5	90215-10284	2 - 22	90480-14812	32 - 2
2SB-F7486-00	28 - 32		31 - 12	2SB-W1510-00	8 - 1	90159-06864	17 - 12	90249-06800	28 - 23	90480-14819	34 - 4
2SB-F7487-00	28 - 35	18C-H3350-01	37 - 16	2SB-W2411-00-P0	21 - 1		21 - 32	90249-12808	28 - 44	90480-15878	21 - 11
2SB-F8100-00	17 - 16	2SB-H3371-00	37 - 17	2SB-W2411-00-P1	21 - 1	90170-05302	3 - 11	90269-06008	16 - 10		21 - 19
5VL-F811G-01	17 - 17	2SB-H3500-00	32 - 1	2SB-W2411-00-P2	21 - 1	90170-10012	2 - 23		22 - 8	90480-24186	17 - 9
2SB-H1168-00	37 - 10	2SB-H3559-00-P0	32 - 5	2SB-W2411-00-P3	21 - 1	90176-10804	18 - 12		22 - 12	90501-03802	10 - 11
2SB-H1410-00	29 - 2	2SB-H3559-00-P1	32 - 5	5VL-W2533-21	25 - 9	90176-22801	19 - 9		33 - 18	90501-06805	13 - 7
2SB-H1450-00	29 - 1	2SB-H3559-00-P2	32 - 5	2SB-W471K-00-P0	22 - 6	90179-06826	28 - 45	90269-07013	36 - 24	90501-10806	28 - 43
2SB-H1800-00	30 - 1	2SB-H3559-00-P3	32 - 5	2SB-W471K-00-P1	22 - 6	90179-08862	35 - 13	90269-09005	17 - 14	90501-18801	2 - 16
4RT-H1801-00	30 - 4	2SB-H3591-00	37 - 6	2SB-W471K-00-P2	22 - 6	90179-12803	11 - 4		18 - 9	90506-12801	25 - 10
1JD-H1828-00	30 - 6	2SB-H3755-00	37 - 9	2SB-W471K-00-P3	22 - 6	90179-14806	11 - 19	90280-03017	2 - 6	90506-15802	25 - 11
4S9-H1834-00	30 - 5	3D9-H3912-30	35 - 8	2SB-W472K-00-P0	22 - 10	90179-25806	19 - 6	90282-05010	2 - 21	90506-26809	28 - 39
2SB-H183G-00	30 - 2	3D9-H3922-02	27 - 11	2SB-W472K-00-P1	22 - 10	90183-05807	16 - 11	90282-05805	11 - 2	90508-32801	14 - 5
5VL-H1940-10	36 - 12	4TU-H3936-00	35 - 16	2SB-W472K-00-P2	22 - 10		17 - 5	90340-12097	5 - 3	90520-02830	33 - 8
54B-H1960-00	36 - 10	2SB-H3972-00	35 - 1	2SB-W472K-00-P3	22 - 10		22 - 17	90387-06158	33 - 11	90520-25801	36 - 5
5VL-H1980-10	36 - 27	2SB-H3975-00	35 - 4	2SB-W4756-00	22 - 4		33 - 9	90387-068N6	9 - 14	90560-15293	23 - 2
2SB-H2021-00	36 - 17	2SB-H3980-00	35 - 14	2SB-Y1119-00	1 - 5		33 - 16	90387-07818	16 - 4	91312-05010	12 - 28
5WY-H2100-10	36 - 4	2SL-H4192-00	33 - 5	2SB-Y1153-00	2 - 12	90185-08008	15 - 8		16 - 9		21 - 29
2SB-H2115-00	36 - 7	2SB-H4300-00	33 - 1	2SB-Y2171-00	17 - 1	90185-10807	28 - 11		17 - 13	91312-05016	3 - 13
2SB-H2116-00	36 - 8	2SB-H4312-00	33 - 7	2SB-Y2172-00	17 - 6	90201-05803	1 - 20		21 - 33	91312-06016	4 - 19
5VL-H2131-01	36 - 6	1SB-H4314-00	33 - 2	90101-06848	25 - 14	90201-05827	32 - 3		22 - 16		9 - 2
4FP-H2151-00	36 - 13	2SB-H4318-00	33 - 3	90101-10818	28 - 8		34 - 5		28 - 33		29 - 4
2SB-H2310-00	36 - 1	1JD-H4347-00	33 - 6	90105-06899	4 - 17	90201-06850	33 - 14		28 - 36		37 - 11
2SB-H2370-00	36 - 3	1SB-H4397-00	33 - 4	90105-08196	4 - 9	90201-068C2	36 - 16	90387-08830	15 - 13	91312-06020	10 - 12
2MP-H2501-00	36 - 18	2SB-H4700-00	34 - 1	90105-08197	1 - 12		36 - 22	90387-155J0	2 - 18		30 - 7
2SB-H2530-00	36 - 25	4KL-H4714-20	34 - 2	90105-088E4	15 - 7	90201-08840	28 - 31	90387-15809	25 - 2		36 - 21
2SB-H2540-00	37 - 3	2SB-H4717-00	34 - 3	90105-10176	15 - 9	90201-088C4	7 - 9	90388-14801	18 - 2	91312-06025	6 - 3
2SB-H2568-00	36 - 23	2SB-H4736-00	34 - 7	90105-10282	15 - 3	90201-10128	37 - 7	90401-10811	27 - 14		29 - 3
1PA-H2576-00	37 - 13	5VL-H5110-30	20 - 16	90105-10831	24 - 15	90201-105E8	10 - 3	90430-06014	1 - 3	91402-20012	28 - 41
2SB-H2590-00	36 - 26		20 - 32	90105-10861	15 - 10	90201-10831	28 - 10		1 - 11	91402-30030	28 - 4
4FP-H2911-00	35 - 7	4FP-H5130-21	37 - 19	90109-06259	14 - 2	90201-108C7	18 - 11	90430-12227	5 - 4	91810-14809	1 - 15
2SB-H2917-00	35 - 15	2SB-H5546-00	37 - 2	90109-06850	35 - 9	90201-108J9	27 - 15	90450-43805	6 - 10		8 - 2
2SB-H3310-00	31 - 1	2SB-H591A-00	37 - 1	90109-08847	25 - 28	90201-12030	29 - 6	90464-09018	37 - 12		9 - 5

零件号码索引  
NUMERICAL INDEX

零件号码 PART NO.	参照 号码	零件号码 PART NO.	参照 号码	零件号码 PART NO.	参照 号码	零件号码 PART NO.	参照 号码	零件号码 PART NO.	参照 号码	零件号码 PART NO.	参照 号码
91810-14809	9 - 18	94110-18803	25 - 25	95812-08016	15 - 6						
92902-06200	11 - 16	94127-18828	23 - 5	95812-08020	22 - 20						
	25 - 40	94568-J2096	4 - 10		28 - 28						
	28 - 24	94668-E2001	25 - 42	95812-08040	7 - 10						
	28 - 42	94700-00415	1 - 13	95812-08065	28 - 30						
93101-10800	9 - 22	95022-06012	1 - 2	95812-10035	18 - 13						
93101-12803	14 - 8	95022-06016	27 - 21	95822-06012	19 - 15						
93102-12802	11 - 26	95022-06020	5 - 8		19 - 18						
93102-20857	23 - 4		36 - 2	95822-06016	16 - 8						
93102-22828	12 - 25	95022-06025	1 - 7		22 - 15						
93104-22802	25 - 5		1 - 10	95822-06020	16 - 5						
93106-26812	25 - 19		27 - 13		33 - 12						
93210-12804	4 - 3	95022-06040	9 - 6	95822-06030	21 - 6						
93210-14899	9 - 9		9 - 19	95822-08016	28 - 14						
93210-19809	9 - 21	95022-06045	8 - 5	97002-06012	33 - 13						
93210-23801	37 - 4	95022-06050	9 - 7	97590-06522	35 - 11						
93210-29811	30 - 8	95022-06055	8 - 4	97602-05220	6 - 28						
93210-30611	6 - 4	95022-06065	5 - 9	97702-50016	17 - 4						
93210-42803	25 - 6	95022-06070	8 - 6		21 - 9						
93210-64800	5 - 10	95022-08020	14 - 11		21 - 17						
93306-002YP	4 - 5	95022-08035	19 - 13		21 - 35						
93306-054X3	25 - 18	95022-08040	19 - 11		22 - 5						
93306-054YD	12 - 8	95302-06600	11 - 17		22 - 9						
93306-201Y8	12 - 9		25 - 15		22 - 13						
93306-202XN	2 - 19		25 - 39		32 - 4						
93306-202Y4	23 - 3		36 - 15		32 - 6						
93306-203XM	12 - 23	95602-06100	35 - 10		33 - 17						
93306-252XA	25 - 4	95602-08200	25 - 24		33 - 21						
93306-252YY	25 - 3		25 - 30		34 - 6						
93306-253YH	2 - 20	95602-10200	15 - 4	98502-05014	26 - 5						
93306-272X8	12 - 24		15 - 11	98502-05016	37 - 5						
93306-305XB	2 - 5	95602-12200	18 - 4	98507-05022	35 - 3						
93306-905Y7	13 - 2	95602-14200	23 - 10	98507-05030	35 - 6						
93306-906X0	4 - 2		25 - 34	98507-05042	35 - 2						
93310-325X7	10 - 6	95612-08635	1 - 4	98507-05050	35 - 5						
93310-628YA	2 - 3	95702-05500	37 - 20	98512-06012	12 - 11						
93317-112X0	11 - 25	95702-08500	7 - 8	98902-05008	30 - 3						
93410-20809	12 - 4	95702-12500	29 - 5	99002-05600	28 - 25						
93410-22820	12 - 15	95802-06010	21 - 13	99002-10600	14 - 6						
93450-16812	2 - 9		21 - 21	99009-10400	10 - 4						
93505-16814	11 - 24		21 - 24	99009-20500	11 - 27						
93604-10800	2 - 17		36 - 9								
93604-10837	13 - 4	95802-06012	28 - 34								
93605-06800	4 - 4		28 - 37								
93608-43238	14 - 7		37 - 18								
93823-14821	12 - 26	95802-06020	9 - 13								
93900-00826	23 - 6		36 - 11								
	25 - 26	95812-06030	6 - 8								





# 雅马哈纯正用品大集结



① 纯色头盔(全盔)

- BL
- RD
- BK



④ 纯色头盔(半盔)

- BL
- RD
- BK



② 锋利头盔(全盔)

- BL
- RD
- BK
- WH



⑤ 锋利头盔(半盔)

- BL
- RD
- BK
- WH



③ 鹰眼头盔(全盔)

- BL
- RD
- BK



⑥ 飞行盔(半盔)

- BL
- BR
- BK
- WH

编号①: Q01-00001-尺寸代码-颜色代码  
 编号②: Q01-00003-尺寸代码-颜色代码  
 编号③: Q01-NS001-尺寸代码-颜色代码

编号④: Q01-00002-尺寸代码-颜色代码  
 编号⑤: Q01-00004-尺寸代码-颜色代码  
 编号⑥: Q01-00006-尺寸代码-颜色代码

尺寸	M	L	XL	XXL
尺寸代码	0M	0L	0X	2X



YAMAHA尾箱

编号: Q41-20000-33-BK

YAMAHA尾箱靠背

编号: Q41-20000-33-CC

# 雅马哈纯正机油大集结



## 纯正机油

品质保证! 动力之源!

请经销YAMALUBE纯正  
机油!



90793-AC421-T1  
90793-AC421-G1  
SAE 10W-40 (1L)  
高等级/通用



90793-AC432-00  
90793-AC432-T1  
SAE 10W-30(1L)  
通用机油



90793-AC404  
SAE 80W-90  
齿轮油  
踏板车专用



90793-AC423-T2  
90793-AC423-G2  
SAE 20W-40 (1L)  
通用机油



90793-AC427-T1  
90793-AC427-G1  
SAE 10W-40 (0.8L)  
弯梁车专用



90793-AC426-T1  
SAE 5W-30 (1L)  
冬季专用/通用



90793-AC434-00  
SAE 10W-30 (0.8L)  
弯梁车专用



90793-AC408  
SAE 85W-140  
齿轮油  
踏板车专用



90793-AC423-P1  
SAE 20W-40 (1L)  
通用机油

友情提示: 磨合期后, 建议每1500KM更换一次机油(可根据实际使用状况减少里程数)。并清洗机油滤网。