

翻印必究



上海雅马哈建设摩托车销售有限公司

<http://www.yamaha-motor.com.cn/>

第一版 2011年5月



SHANGHAI YAMAHA JIANSHE MOTOR MARKETING CO., LTD.

零件目录

XC100E(4S09)
XC100E(4S0A)

4S0-F8198-1K-M1

1K4S0-415M1



XC100E(4S09)/XC100E(4S0A)



4S09 (手制动/鼓刹)

代号	颜色
0376	深鸡尾红色2



代号	颜色
0627	特暗蓝4



代号	颜色
0903	金属黑色



代号	颜色
0390	浅蓝鸡尾白色1



4S0A (手制动/碟刹)

代号	颜色
0791	银3



代号	颜色
00UG	棕色



代号	颜色
0903	金属黑色



代号	颜色
0390	浅蓝鸡尾白色1



前言

本零件目录记载着封面页所示型号所使用的零件。当您订购更换零件时，请参阅本零件目录并正确指示零件号码和零件名称。

1. 零件目录发行后有变更或附加零件时，将会以雅马哈零件信息通知大家。
建议您应按照雅马哈零件信息修改本零件目录。

2. 省略记号
本文中所记载的省略记号的意思如下。

“UR” 需要指定的零件号码。

“UN” 需要数。

“AP” 选购品

“LM” 当地制造（必需于当地订购的零件）

“F#” 车架号（适用的机器号）

“O/S” 超过尺寸

3. 组件中部件的数量

- 组件的销售零件，如下所示，在零件名称的前面加上（.）的记号来表示。
- 每个部件右侧的数字表示各组件单体内该部件的数量。

零件号码	零件名称	数量	备注
2F5 - 83310 - 60	前闪光灯组合	2	
115 - 83311 - 60	. 灯泡 (6V - 18W)	1	

4. 适用的图形颜色表示在“备注”中，如下所示。

零件号码	零件名称	数量	备注
2N4 - 24110 - 00 - X5	燃油箱组件	2	MXR
3J1 - 24240 - 10	. 燃油箱图形	1	适用于 MXR

5. 请注意插图只用于找寻零件号码时参照，并不适用于组装。组装时，请使用适用的维修手册。

6. 在参照号码前的星号（*）表示其为在第一版后更改的项目。

前言

7. 适用的系列号码

车架系列号

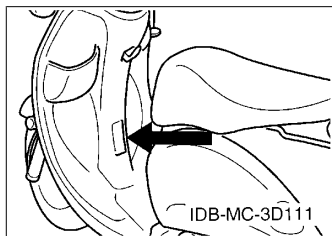

发动机系列号码

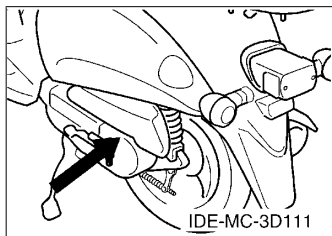

8. 适用的颜色记号 (*标志表示型号颜色。)

省略记号	颜色名称 (英文)	颜色名称	颜色记号
BWC1(*)	BLUISH WHITE COCKTAIL 1	浅蓝鸡尾白色 1	0390
DGM1	DARK GRAY METALLIC 1	黑灰	00C1
DRC2(*)	DEEP RED COCKTAIL 2	深鸡尾红色 2	0376
IPB(*)	IMPERIAL BROWN	棕色	00UG
S3(*)	SILVER 3	银 3	0791
SL	SILVER	银色	0035
SMX(*)	BLACK METALLIC X	金属黑色	0903
VDBC4(*)	VERY DARK BLUE COCKTAIL 4	特暗蓝 4	0627

9. 适用的初始系列号码

车架系列号

系列号码	数量栏名称	型号记号

发动机系列号码

系列号码	数量栏名称	型号记号

型号信息

10. 颜色信息

型号代码	颜色类型代码	颜色记号	颜色名称 (英文)	颜色名称	省略记号
4S09	A	0376	DEEP RED COCKTAIL 2	深鸡尾红色 2	DRC2
	B	0627	VERY DARK BLUE COCKTAIL 4	特暗蓝 4	VDBC4
	C	0903	BLACK METALLIC X	金属黑色	SMX
	D	0390	BLUIISH WHITE COCKTAIL 1	浅蓝鸡尾白色 1	BWC1
4S0A	A	0791	SILVER 3	银 3	S3
	B	00UG	IMPERIAL BROWN	棕色	IPB
	C	0903	BLACK METALLIC X	金属黑色	SMX
	D	0390	BLUIISH WHITE COCKTAIL 1	浅蓝鸡尾白色 1	BWC1

目录

发动机

气缸头.....	1
曲柄·活塞.....	3
凸轮轴·链条.....	4
空气罩&风扇.....	5
油泵.....	6
进气门.....	7
化油器.....	8
排气装置.....	9
曲轴箱.....	11
起动机.....	13
离合器.....	14
传动.....	16

车体

车架.....	17
挡泥板.....	18
侧盖.....	20
后臂·悬挂.....	23
前叉(鼓刹).....	24
前叉(碟刹).....	26
油箱.....	28
座位.....	30
前轮(鼓刹).....	31
前轮(碟刹).....	33
前制动器卡钳.....	34
后轮.....	35
操纵手柄 钢索(鼓刹).....	36
操纵手柄 钢索(碟刹).....	37
前主缸.....	38
搁脚·支架.....	39
护腿.....	40
导流罩 1.....	41
发电机.....	42
起动机.....	43
转向灯.....	44
仪表.....	45
前大灯.....	46
尾灯.....	47
手柄开关(鼓刹).....	48

手柄开关(碟刹).....	49
电气系统 1.....	50
电气系统 2.....	51

索引

零件号码索引.....	52
-------------	----

CONTENTS

ENGINE

CYLINDER HEAD.....	1
CRANKSHAFT & PISTON.....	3
CAMSHAFT & CHAIN.....	4
AIR SHROUD & FAN.....	5
OIL PUMP.....	6
INTAKE.....	7
CARBURETOR.....	8
EXHAUST.....	9
CRANKCASE.....	11
STARTER.....	13
CLUTCH.....	14
TRANSMISSION.....	16

CHASSIS

FRAME.....	17
FENDER.....	18
SIDE COVER.....	20
REAR ARM & SUSPENSION.....	23
FRONT FORK FOR DRUM BRAKE.....	24
FRONT FORK FOR DISK BRAKE.....	26
FUEL TANK.....	28
SEAT.....	30
FRONT WHEEL FOR DRUM BRAKE.....	31
FRONT WHEEL FOR DISK BRAKE.....	33
FRONT BRAKE CALIPER.....	34
REAR WHEEL.....	35
STEERING CABLE FOR DRUM BRAKE.....	36
STEERING CABLE FOR DISK BRAKE.....	37
FRONT MASTER CYLINDER.....	38
STAND & FOOTREST.....	39
LEG SHIELD.....	40
COWLING 1.....	41
GENERATOR.....	42
STARTING MOTOR.....	43
FLASHER LIGHT.....	44
METER.....	45
HEADLIGHT.....	46
TAILLIGHT.....	47
SWITCH & LEVER FOR DRUM BRAKE.....	48

SWITCH & LEVER FOR DISK BRAKE.....	49
ELECTRICAL 1.....	50
ELECTRICAL 2.....	51

INDEX

NUMERICAL INDEX.....	52
----------------------	----

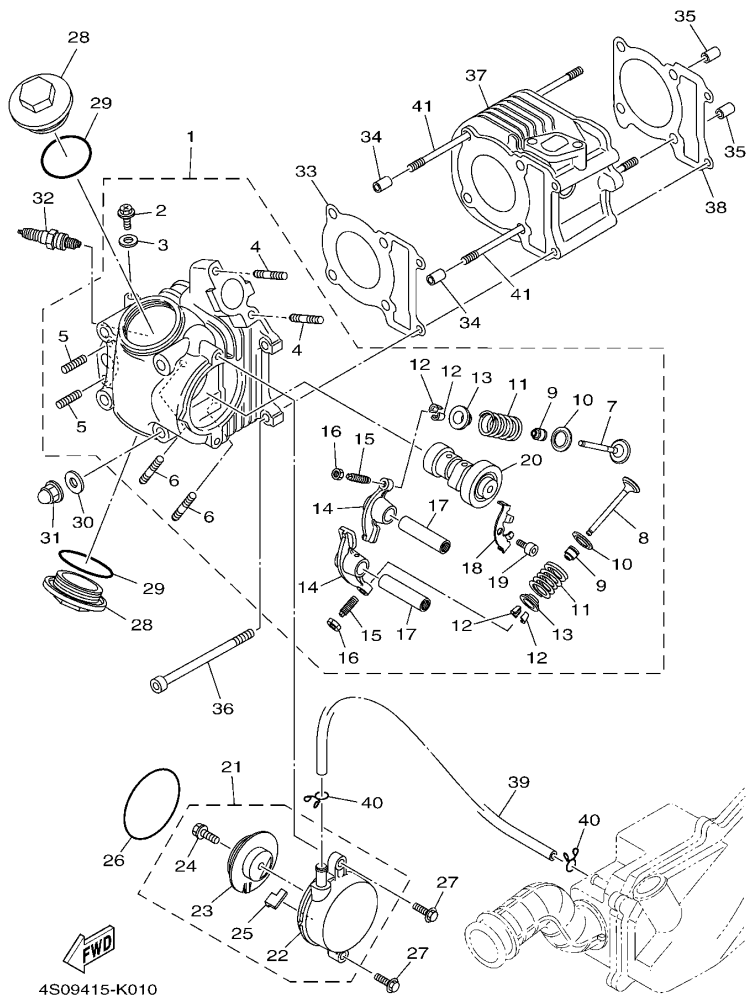

4S09415-K010

FIG. 1 气缸头

CYLINDER HEAD

参照 号码	零件号码 PART NO.	零件名称 DESCRIPTION	4S09	4S0A	备注 REMARKS
1	1CC-X1111-00	气缸头 1 组合 CYLINDER HEAD ASSY	1	1	
2	90153-06803	.六角头螺钉 .SCREW, HEXAGON	1	1	
3	90430-06014	.衬垫 .GASKET	1	1	
4	1CC-E4651-00	.螺栓 .BOLT	2	2	
5	90113-06804	.离合杆螺栓 .BOLT, SET	2	2	
6	90116-06805	.双头螺栓 .BOLT, STUD	2	2	
7	1CC-E2111-00	.进气门 .VALVE, INTAKE	1	1	
8	1CC-E2121-00	.排气门 .VALVE, EXHAUST	1	1	
9	1CC-E2119-00	.气门油封 .SEAL, VALVE STEM	2	2	
10	1CC-E2116-00	.气门弹簧座 .SEAT, VALVE SPRING	2	2	
11	1CC-E2113-00	.气门内弹簧 .SPRING, VALVE INNER	2	2	
12	1CC-E2118-00	.气门锁夹 .COTTER, VALVE	4	4	
13	1CC-E2117-00	.气门弹簧座 .RETAINER, VALVE SPRING	2	2	
14	1CC-E2151-00	.气门摇臂 .ARM, VALVE ROCKER	2	2	
15	1CC-E2159-00	.气门调整螺钉 .SCREW, VALVE ADJUSTING	2	2	
16	90170-05801	.螺母 .NUT	2	2	
17	1CC-E2156-00	.摇臂轴 2 .SHAFT, ROCKER 2	2	2	
18	1CC-E111F-00	.面板 .PLATE	1	1	
19	91312-06012	.螺栓 .BOLT	1	1	
20	1CC-E2170-00	.凸轮轴组合 1 .CAMSHAFT ASSY 1	1	1	
21	1CC-E1160-01	.通气管组合 BREATHER ASSY	1	1	
22	1CC-E1185-00	.气缸头侧盖 3 .COVER, CYLINDER HEAD SIDE 3	1	1	
23	1CC-E1165-00	.通气管面板 .PLATE, BREATHER	1	1	
24	97522-06512	.带垫螺栓 .BOLT, WITH WASHER	1	1	
25	1CC-E1155-00	.曲折环式密封圈 .SEAL, LABYRINTH	1	1	
26	.O 型环 O-RING	1	1		
27	95022-06020	.凸缘螺栓 BOLT, FLANGE	2	2	

FIG. 1 气缸头

CYLINDER HEAD

参照 号码	零件号码 PART NO.	零件名称 DESCRIPTION	4S09	4S0A	备注 REMARKS
28	4KL-E1186-00	气缸头侧盖 2 COVER, CYLINDER HEAD SIDE 2	2	2	
29	93210-44808	O型环 O-RING	2	2	
30	90201-08827	平垫圈 WASHER, PLATE	4	4	
31	90176-08811	盖型螺母 NUT, CROWN	4	4	
32	94700-00869	火花塞 PLUG SPARK (NGK CR6HSA)	1	1	
33	1CC-E1181-00	气缸头衬垫 1 GASKET, CYLINDER HEAD 1	1	1	
34	91810-14805	定位销 PIN, DOWEL	2	2	
35	91810-14805	定位销 PIN, DOWEL	2	2	
36	91312-06090	螺栓 BOLT	2	2	
37	1CC-E1310-02	气缸 CYLINDER	1	1	
38	1CC-E1351-00	气缸衬垫 GASKET, CYLINDER	1	1	
39	4S0-E4987-00	软管 HOSE	1	1	
40	90467-13804	卡环 CLIP	2	2	
41	90116-08811	双头螺栓 BOLT, STUD	4	4	

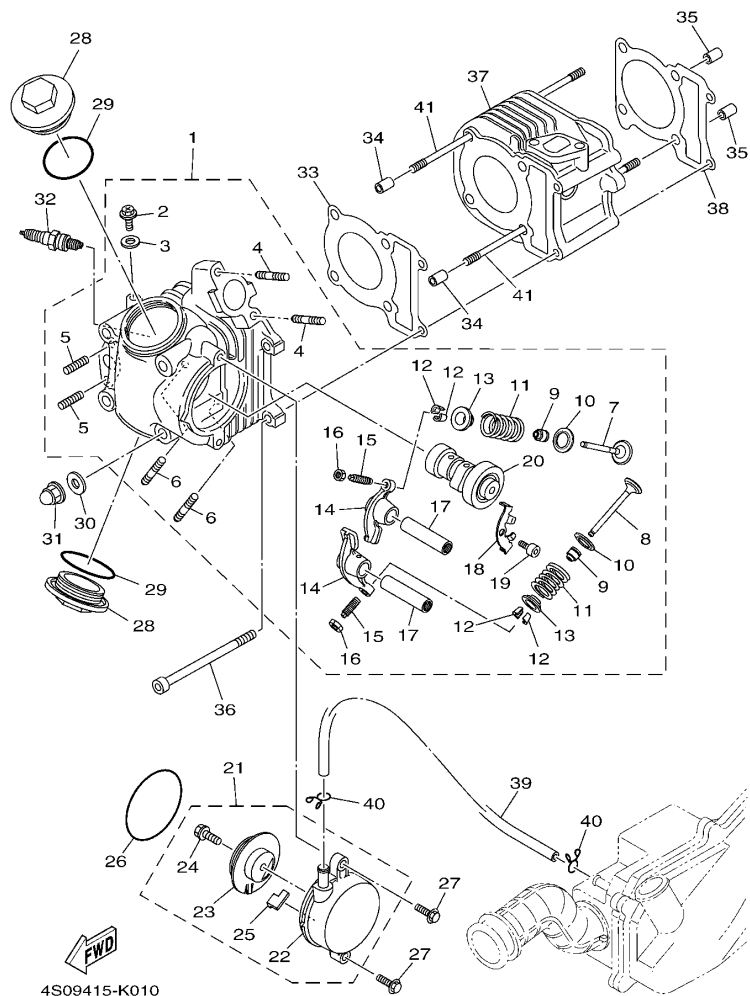
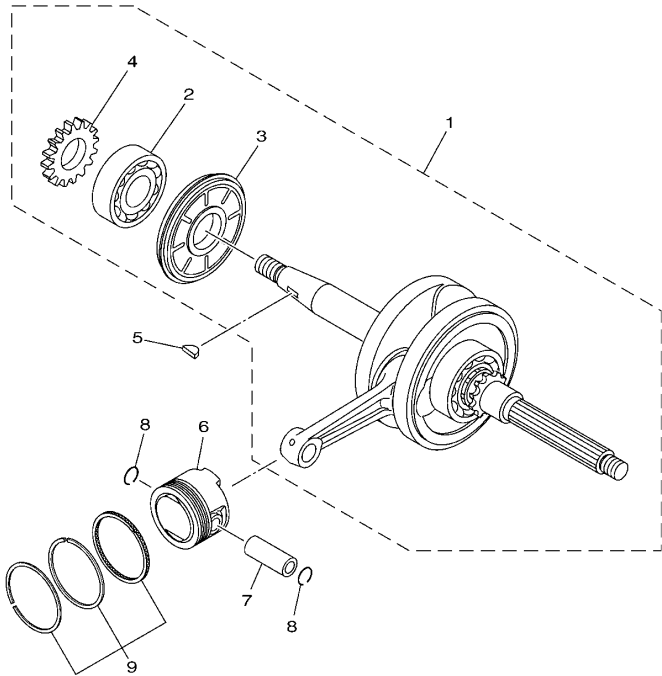

FIG. 2 曲柄·活塞

CRANKSHAFT & PISTON

参照 号码	零件号码 PART NO.	零件名称 DESCRIPTION	4S09	4S0A		备注 REMARKS
1	1CC-E1400-00	曲轴组合 CRANKSHAFT ASSY	1	1		
2	93306-205XY	.轴承 .BEARING	1	1		
3	1CC-E3451-00	.转子过滤器 .FILTER,ROTARY	1	1		
4	1CC-E3324-00	.机油泵驱动齿轮 .GEAR, PUMP DRIVE	1	1		
5	90280-03045	半圆键 KEY, WOODRUFF	1	1		
6	1CC-E1631-00	活塞(STD) PISTON (STD)	1	1		
7	1CC-E1633-00	活塞销 PIN, PISTON	1	1		
8	93450-15825	卡环 CIRCLIP	2	2		
9	1CC-E1603-00	活塞环套件(STD) PISTON RING SET (STD)	1	1		



FWD
4S01415-E020

FIG. 3 凸轮轴·链条

CAMSHAFT & CHAIN

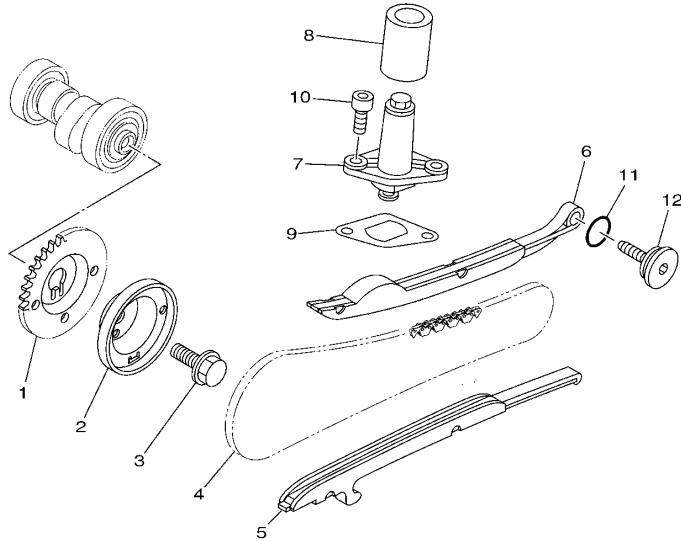

参照 号码	零件号码 PART NO.	零件名称 DESCRIPTION	4SD9	4SDA	备注 REMARKS
1	1CC-E2176-00	链轮 SPROCKET, CAM CHAIN	1	1	
2	1CC-E1145-00	通气管面板 2 PLATE, BREATHER 2	1	1	
3	95812-08016	凸缘螺栓 BOLT, FLANGE	1	1	
4	94568-A2084	链条 CHAIN	1	1	
5	1CC-E2231-00	导向限位板 1 GUIDE, STOPPER 1	1	1	
6	1CC-E2241-00	导向限位板 2 GUIDE, STOPPER 2	1	1	
7	4KL-E2210-00	链条张紧器组合 TENSIONER ASSY, CAM CHAIN	1	1	
8	4KL-E2232-00	减震器 DAMPER	1	1	
9	5MH-E2213-10	张紧器垫片 GASKET, TENSIONER CASE	1	1	
10	91312-06016	螺栓 BOLT	2	2	
11	93210-15171	O型环 O-RING	1	1	
12	5MH-E2157-01	锁紧螺母 BOLT	1	1	

FIG. 4 空气罩&风扇

AIR SHROUD & FAN

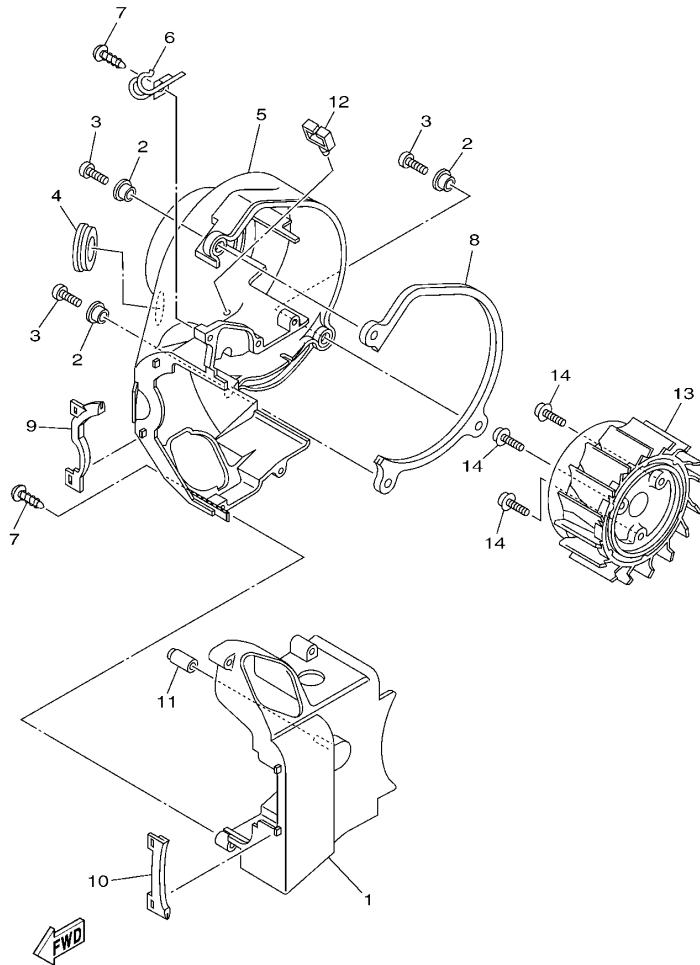

1CC1415-K040

参照 号码	零件号码 PART NO.	零件名称 DESCRIPTION	4S09	4S0A	备注 REMARKS
1	1CC-E2651-00	气缸空气罩 1 AIR SHROUD, CYLINDER 1	1	1	
2	90387-068K5	轴套 COLLAR	3	3	
3	98502-06020	十字螺钉 SCREW, PAN HEAD	3	3	
4	90480-30800	橡胶垫 GROMMET	1	1	
5	1CC-E2652-00	气缸空气罩 2 AIR SHROUD, CYLINDER 2	1	1	
6	90465-12803	夹箍 CLAMP	1	1	
7	97702-60530	自攻螺钉 SCREW, TAPPING	5	5	
8	1CC-E2658-00	冷却风道避震垫 1 DAMPER, AIR SHROUD 1	1	1	
9	1CC-E2659-00	冷却风道避震垫 2 DAMPER, AIR SHROUD 2	1	1	
10	1CC-E2668-00	冷却风道避震垫 3 DAMPER, AIR SHROUD 3	1	1	
11	1CC-E3569-00	绝缘插头 PLUG, BLIND	1	1	
12	90464-08020	线夹 CLAMP	1	1	
13	1CC-E2611-00	风扇 FAN	1	1	
14	97602-06214	带垫圈大柱头螺钉 SCREW, PAN HEAD WITH WASHER	3	3	

FIG. 5 油泵

OIL PUMP

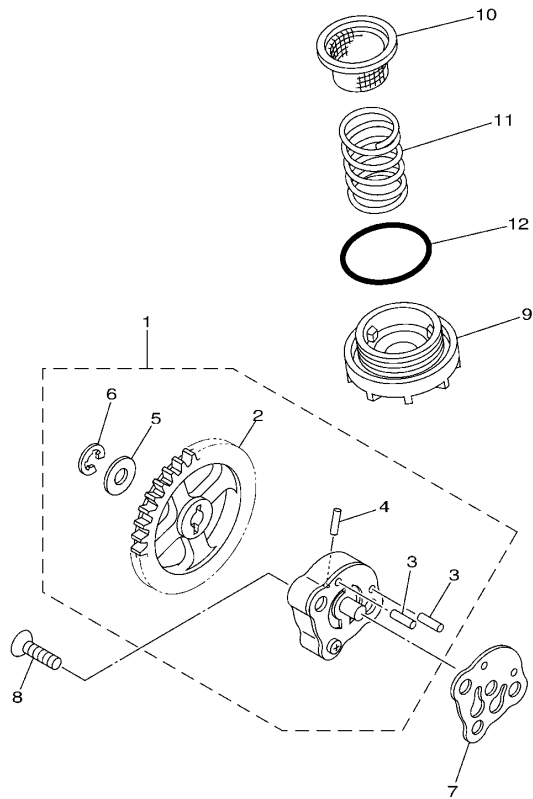

1CC1415-K050

参照 号码	零件号码 PART NO.	零件名称 DESCRIPTION	4S09	4S0A			备注 REMARKS
1	1CC-E3300-00	机油泵总成 OIL PUMP ASSY	1	1			
2	1CC-E3325-00	.从动齿轮 .GEAR, PUMP DRIVEN	1	1			
3	93603-12802	.定位销 .PIN, DOWEL	2	2			
4	93602-12801	.定位销 .PIN, DOWEL	1	1			
5	90201-07811	.平垫圈 .WASHER, PLATE	1	1			
6	99001-05600	.卡环 .CIRCLIP	1	1			
7	5MH-E3475-00	衬垫 GASKET	1	1			
8	98702-06020	平头螺钉 SCREW, FLAT HEAD	2	2			
9	4KL-E5351-10	放油塞 PLUG, DRAIN	1	1			
10	4KL-E3411-01	机油滤网 STRAINER, OIL	1	1			
11	90501-16829	压簧 SPRING, COMPRESSION	1	1			
12	93210-34803	O型环 O-RING	1	1			

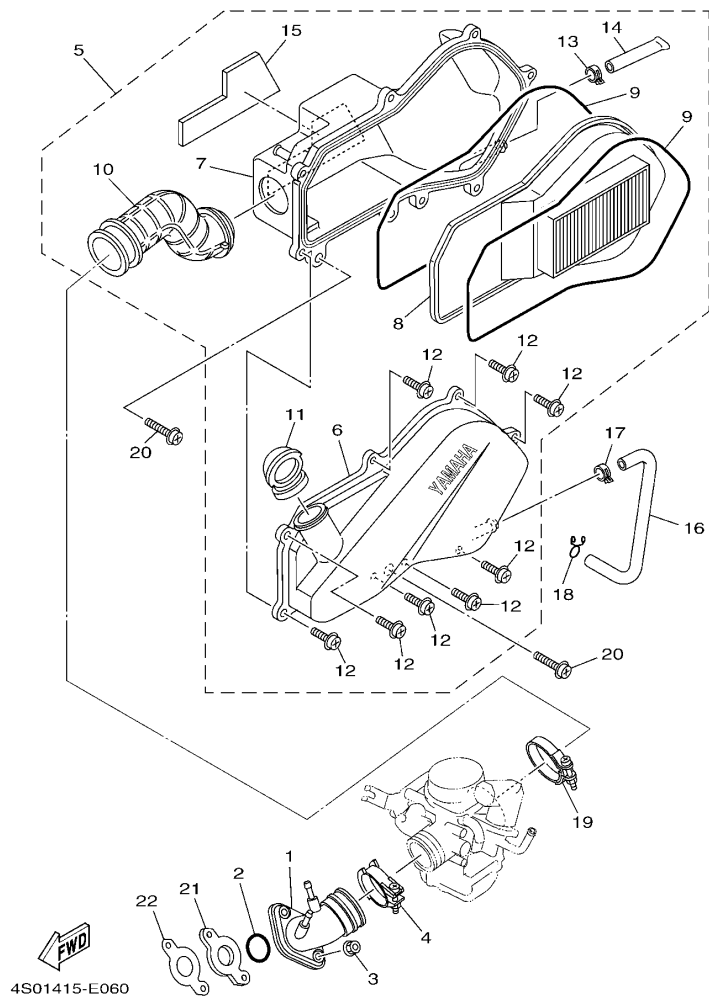

FIG. 6 进气门

INTAKE

参照 号码	零件号码 PART NO.	零件名称 DESCRIPTION	4S09	4S0A	备注 REMARKS
1	1CC-E3585-00	岐管 MANIFOLD	1	1	
2	93210-25806	O型环 O-RING	1	1	
3	95702-06500	螺母 NUT, FLANGE	2	2	
4	1CC-E3575-00	箍带 BAND	1	1	
5	4S0-E4410-03	空气净化器组合 AIR CLEANER ASSY.	1	1	
6	4S0-E4412-01	.空气净化器箱盖 1 .CAP, CLEANER CASE 1	1	1	
7	4S0-E4411-02	.空气净化器箱 1 .CASE, AIR CLEANER 1	1	1	
8	4S0-E4451-01	.空气滤芯 .ELEMENT, AIR CLEANER	1	1	
9	5WG-E4476-00	.密封圈 .SEAL	2	2	
10	4S0-E4453-00	.空气净化器接头 1 .JOINT, AIR CLEANER 1	1	1	
11	4S0-E4437-00	.导管 .DUCT	1	1	
12	97602-06220	.带垫圈大柱头螺钉 .SCREW, PAN HEAD W/WASHER	8	8	
13	90467-13817	.卡环 .CLIP	1	1	
14	5WY-E443E-01	.排水管 .PIPE, DRAIN	1	1	
15	4S0-E4409-00	.减震器 .DAMPER	1	1	
16	4S0-E443G-00	排气管 PIPE, DRAIN 2	1	1	
17	90467-13815	卡环 CLIP	1	1	
18	90467-12814	卡环 CLIP	1	1	
19	90450-45801	软管夹组合 HOSE CLAMP ASSY	1	1	
20	97602-06225	带垫圈大柱头螺钉 SCREW, PAN HEAD WITH WASHER	2	2	
21	1CC-E3595-00	接头 JOINT	1	1	
22	1CC-E3556-00	岐管衬垫 GASKET, MANIFOLD	1	1	

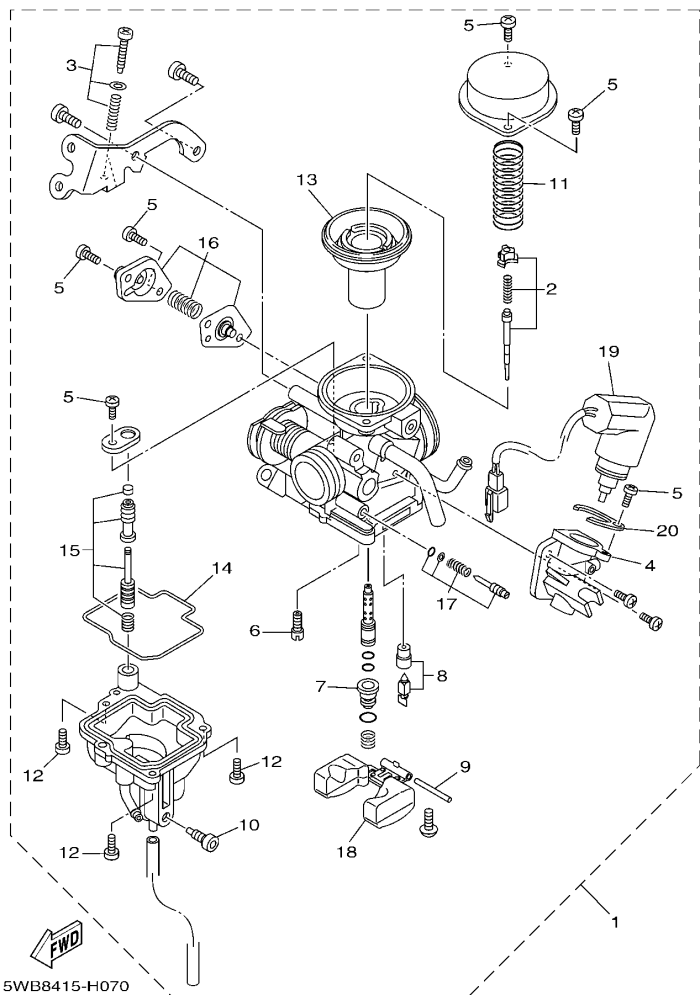

FIG. 7 化油器

CARBURETOR

参照 号码	零件号码 PART NO.	零件名称 DESCRIPTION	4S09	4S0A	备注 REMARKS
1	1CC-E4301-00	化油器总成 1 CARBURETOR ASSY 1	1	1	
2	5WB-E490J-30	. 滚针套件 . NEEDLE SET	1	1	
3	5WB-E490K-10	. 止动螺钉套件 . STOP SCREW SET	1	1	
4	5WB-E4283-10	. 化油器盖 1 . COVER, CARBURETOR 1	1	1	
5	98501-04008	. 十字螺钉 . SCREW, PAN HEAD	6	6	
6	5WB-E4342-16	. 低速量孔 (# 32) . JET, PILOT (# 32)	1	1	
7	5WB-E4343-52	. 主量孔 (#104) . JET, MAIN (#104)	1	1	
8	5WB-E4390-00	. 针阀组合 . NEEDLE VALVE ASSY	1	1	
9	5LB-E4386-00	. 浮子销 . PIN, FLOAT	1	1	
10	5WB-E4115-00	. 螺旋 . PLUG, SCREW	1	1	
11	5WB-E4286-10	. 弹簧 . SPRING	1	1	
12	97601-04014	. 带垫十字螺钉 . SCREW, PAN HEAD WITH WASHER	3	3	
13	5WB-E4340-00	. 阀组合 . VALVE ASSY	1	1	
14	5WB-E4384-10	. 浮子室衬垫 . GASKET, FLOAT CHAMBER	1	1	
15	5WB-E4504-00	. 杆套 . ROD SET	1	1	
16	5WB-E490A-10	. 隔膜套件 1 . DIAPHRAGM SET 1	1	1	
17	5WB-E4105-10	. 混合气调整螺钉组件 . PILOT SCREW SET	1	1	
18	5WB-E4385-10	. 浮子 . FLOAT	1	1	
19	5WB-E4370-10	. 柱塞起动机组合 . PLUNGER STARTER ASSY	1	1	
20	5WB-E4346-00	. 面板 . PLATE	1	1	

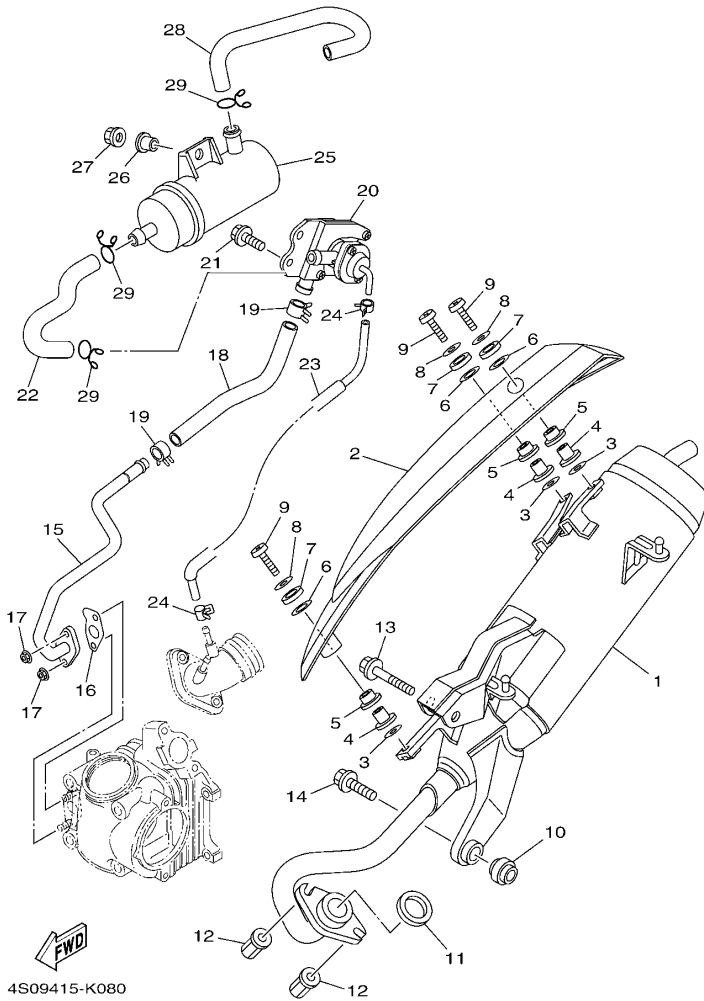

FIG. 8 排气装置

EXHAUST

参照 号码	零件号码 PART NO.	零件名称 DESCRIPTION	4S09	4S0A	备注 REMARKS
1	5WY-E4610-80	排气管组合 1 EXHAUST PIPE ASSY 1	1	1	
2	5WY-E4708-10	保护件组合 PROTECTOR ASSY	1	1	
3	5WB-E4766-10	保护件垫圈 WASHER, PROTECTOR	3	3	
4	5WY-E4779-01	安装套 COLLAR	3	3	
5	5WY-E4445-00	固定套 GROMMET	3	3	
6	5WY-E4759-01	垫圈 WASHER	3	3	
7	5WY-E4617-00	垫圈 WASHER	3	3	
8	90201-06814	平垫圈 WASHER, PLATE	3	3	
9	98980-06020	螺钉 SCREW, BIND	3	3	
10	4KL-E4737-00	消音器减震器 DAMPER, MUFFLER	1	1	
11	4KL-E4613-10	排气管衬垫 GASKET, EXHAUST PIPE	1	1	
12	90179-06850	螺母 NUT	2	2	
13	95812-08050	凸缘螺栓 BOLT, FLANGE	1	1	
14	95812-08030	凸缘螺栓 BOLT, FLANGE	1	1	
15	5WY-E4872-30	管 2 PIPE 2	1	1	
16	5WG-E4815-00	衬垫 GASKET	1	1	
17	95702-06500	螺母 NUT, FLANGE	2	2	
18	4S0-E4883-00	弯曲软管 3 HOSE, BEND 3	1	1	
19	90467-16805	卡环 CLIP	2	2	
20	5WB-E4803-11	二次进气系统 AIR INDUCTION SYSTEM ASSY	1	1	
21	95802-06012	凸缘螺栓 BOLT, FLANGE	2	2	
22	4S0-E4884-00	弯曲软管 4 HOSE, BEND 4	1	1	
23	4S0-E3542-10	负压传感软管 1 HOSE, VACUUM SENSING 1	1	1	
24	90467-08070	卡环 CLIP	2	2	
25	5WG-E4806-01	空气滤芯器 AIR FILTER	1	1	
26	90387-068J2	轴套 COLLAR	1	1	
27	95702-06500	螺母 NUT, FLANGE	1	1	

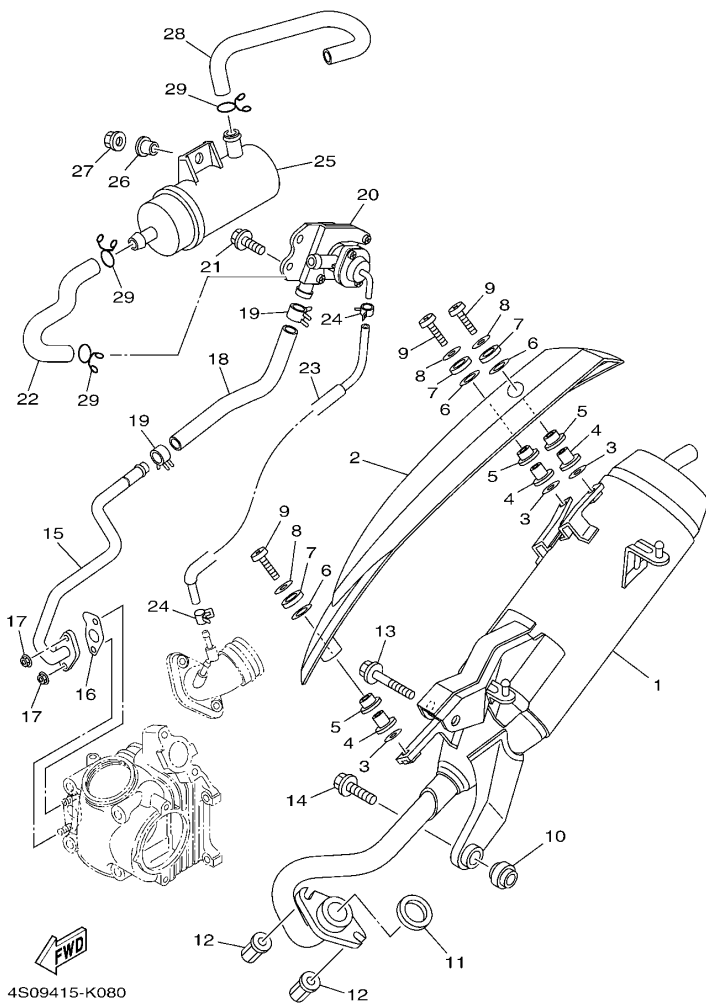
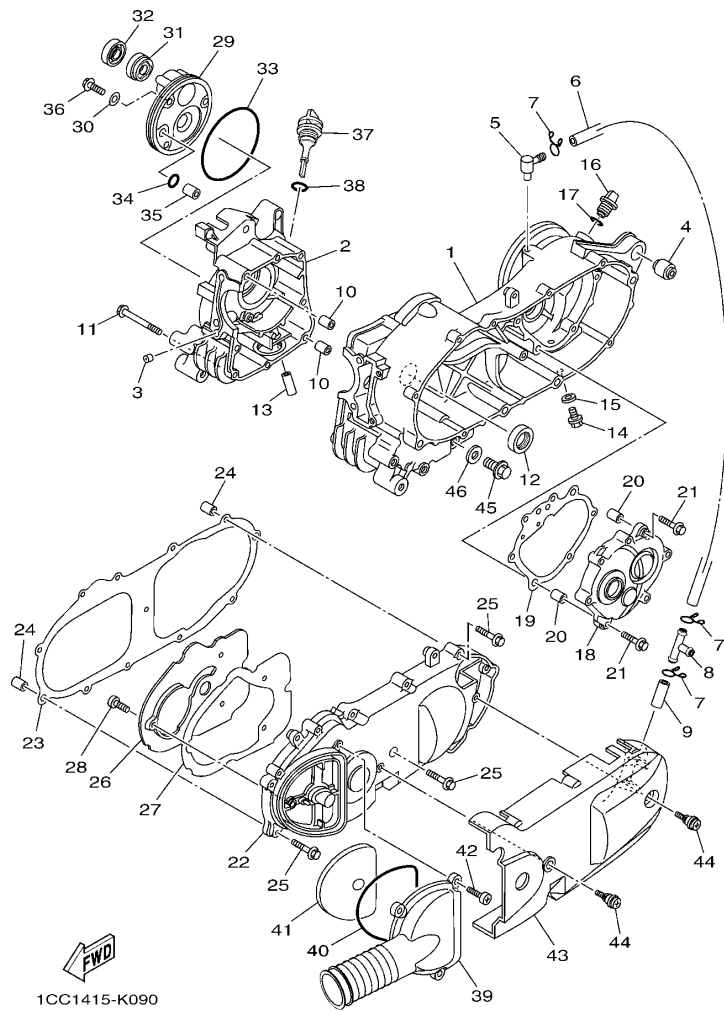

FIG. 8 排气装置

EXHAUST

参照 号码	零件号码 PART NO.	零件名称 DESCRIPTION	4S09	4S0A		备注 REMARKS
28	4S5-E4885-00	弯曲软管 5 HOSE, BEND 5	1	1		
29	90467-16808	卡环 CLIP	3	3		



1CC1415-K090

FIG. 9 曲轴箱

CRANKCASE

参照 号码	零件号码 PART NO.	零件名称 DESCRIPTION	4S09	4S0A	备注 REMARKS
1	1CC-E5111-00	曲轴箱 1 CRANKCASE 1	1	1	
2	1CC-E5121-00	曲轴箱 2 CRANKCASE 2	1	1	
3	1CC-E5138-00	喷管 1 NOZZLE 1	1	1	
4	4KL-F2216-00	后减震器衬套 BUSH, REAR SHOCK ABSORBER	1	1	
5	1CC-E5371-00	通气管接头 BREATHER	1	1	
6	1CC-E5373-00	通气管 PIPE, BREATHER	1	1	
7	90467-12814	卡环 CLIP	3	3	
8	90413-12800	轨道 3 WAY 3	1	1	
9	4S0-E5393-00	通气管 2 PIPE, BREATHER 2	1	1	
10	91810-14805	定位销 PIN, DOWEL	2	2	
11	95022-06070	凸缘螺栓 BOLT, FLANGE	8	8	
12	93102-22811	油封 OIL SEAL	1	1	
13	1CC-E3416-00	机油管 1 PIPE, OIL 1	1	1	
14	95812-08016	凸缘螺栓 BOLT, FLANGE	1	1	
15	90430-08119	衬垫 GASKET	1	1	
16	4KL-E5363-00	机油塞 PLUG, OIL	1	1	
17	93210-14815	O型环 O-RING	1	1	
18	1CC-E5421-00	曲轴箱盖 2 COVER, CRANKCASE 2	1	1	
19	1CC-E5461-00	曲轴箱盖衬垫 2 GASKET, CRANKCASE COVER 2	1	1	
20	91810-14805	定位销 PIN, DOWEL	2	2	
21	95022-06030	凸缘螺栓 BOLT, FLANGE	7	7	
22	1CC-E5411-00	曲轴箱盖 1 COVER, CRANKCASE 1	1	1	
23	1CC-E5451-00	曲轴箱盖衬垫 1 GASKET, CRANKCASE COVER 1	1	1	
24	91810-14805	定位销 PIN, DOWEL	2	2	
25	95022-06035	凸缘螺栓 BOLT, FLANGE	12	12	
26	1CC-E5191-00	面板 PLATE	1	1	
27	1CC-E5455-00	衬垫 1 GASKET 1	1	1	

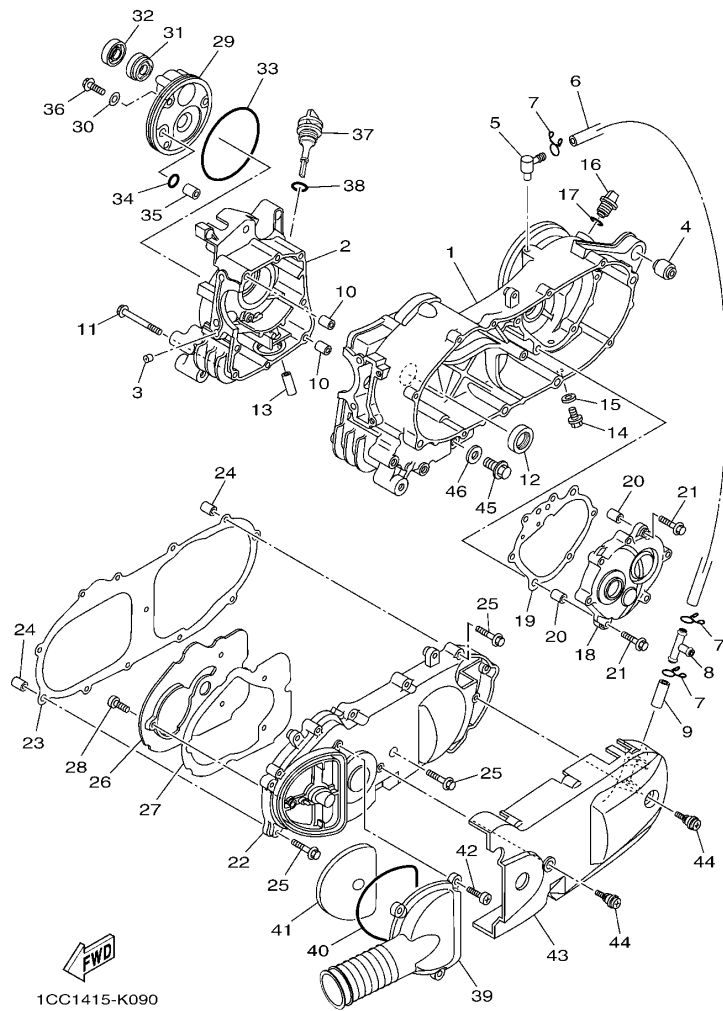

FIG. 9 曲轴箱

CRANKCASE

参照 号码	零件号码 PART NO.	零件名称 DESCRIPTION	4SD9	4SDA	备注 REMARKS
28	98902-06010	十字槽盘头螺钉 SCREW, BIND	3	3	
29	1CC-E5417-00	帽盖 COVER, CAP	1	1	
30	90430-06014	衬垫 GASKET	3	3	
31	93102-19805	油封 OIL SEAL	1	1	
32	93102-19810	油封 OIL SEAL	1	1	
33	93211-02802	O 型环 O-RING	1	1	
34	93210-07809	O 型环 O-RING	1	1	
35	91808-12804	定位销 PIN, DOWEL	1	1	
36	95022-06020	凸缘螺栓 BOLT, FLANGE	3	3	
37	1CC-E5363-10	机油塞 PLUG, OIL	1	1	
38	93210-26812	O 型环 O-RING	1	1	
39	1CC-E5471-00	空气导管 DUCT, AIR	1	1	
40	1CC-E5472-00	空气导管密封圈 SEAL, AIR DUCT	1	1	
41	1CC-E5407-00	滤芯 1 ELEMENT 1	1	1	
42	98902-06020	十字槽盘头螺钉 SCREW, BIND	3	3	
43	1CC-X1543-00	曲轴箱盖 3 COVER, CRANKCASE 3	1	1	
44	1CC-E5481-00	螺栓 1 BOLT 1	2	2	
45	90340-12806	放油旋 PLUG, STRAIGHT SCREW	1	1	
46	90201-12172	平垫圈 WASHER, PLATE	1	1	

FIG. 10 起动器

STARTER

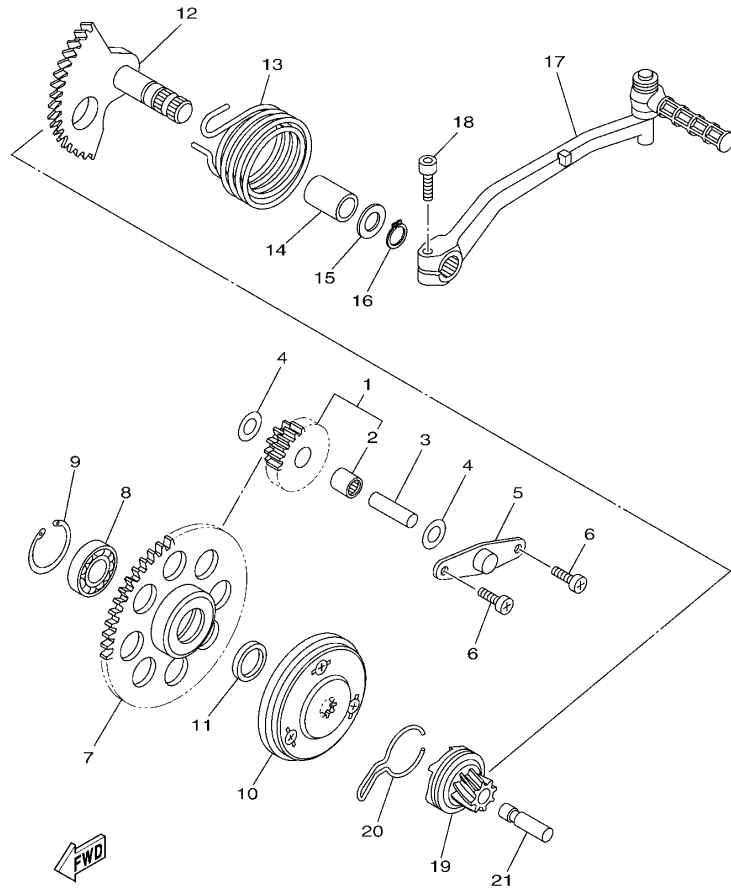

1CC1415-K100

参照 号码	零件号码 PART NO.	零件名称 DESCRIPTION	4S09	4S0A	备注 REMARKS
1	1CC-E5650-00	空转齿轮组合 IDLE GEAR ASSY	1	1	
2	93317-110Y4	.轴承 .BEARING	1	1	
3	5WG-E5521-00	轴 1 SHAFT 1	1	1	
4	90201-108A3	平垫圈 WASHER, PLATE	2	2	
5	5MH-E5532-00	惰齿轮面板 PLATE, IDLE GEAR	1	1	
6	98502-06012	十字螺钉 SCREW, PAN HEAD	2	2	
7	1CC-E5524-00	起动齿轮 WHEEL, STARTER	1	1	
8	93306-003X8	轴承 BEARING	1	1	
9	99009-35700	卡环 CIRCLIP	1	1	
10	1CC-E5570-00	起动离合器组合 STARTER CLUTCH ASSY	1	1	
11	90387-16806	轴套 COLLAR	1	1	
12	1CC-E5601-00	起动轴组合 KICK SHAFT ASSY	1	1	
13	90508-32804	扭簧 SPRING, TORSION	1	1	
14	90380-15806	固体套管 BUSH, SOLID	1	1	
15	90201-15838	平垫圈 WASHER, PLATE	1	1	
16	99009-15400	卡环 CIRCLIP	1	1	
17	1CC-E5620-00	起动曲柄组合 KICK CRANK ASSY	1	1	
18	91312-06025	螺栓 BOLT	1	1	
19	1CC-E5630-00	起动小齿轮组合 KICK PINION ASSY	1	1	
20	1CC-E5673-00	钢夹 CLIP	1	1	
21	1CC-E5659-00	轴 SHAFT	1	1	

FIG. 11 离合器

CLUTCH

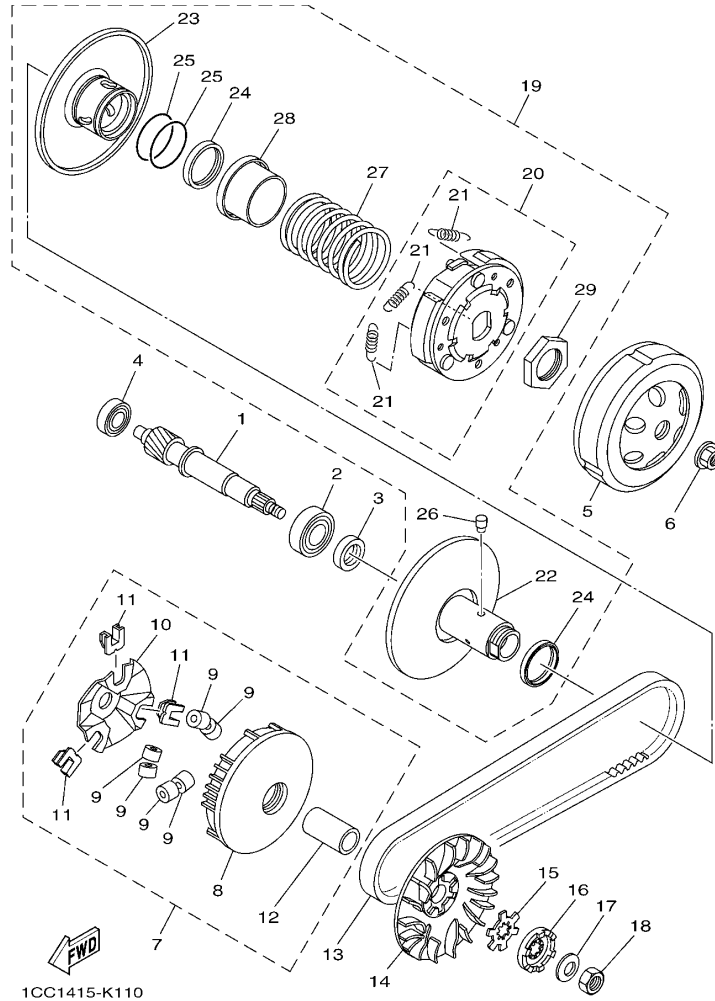

1CC1415-K110

参照 号码	零件号码 PART NO.	零件名称 DESCRIPTION	4S09	4S0A	备注 REMARKS
1	1CC-E6111-00	初级驱动齿轮 GEAR, PRIMARY DRIVE	1	1	
2	93306-253Y0	轴承 BEARING	1	1	
3	93102-17808	油封 OIL SEAL	1	1	
4	93306-200X0	轴承 BEARING	1	1	
5	1CC-E6611-01	离合器壳体组合 CLUTCH HOUSING COMP.	1	1	
6	90179-10817	螺母 NUT	1	1	
7	1CC-E7601-00	主槽轮组合 PRIMARY SHEAVE ASSY	1	1	
8	1CC-E7620-00	主滑轮组合 PRIMARY SLIDING SHEAVE COMP.	1	1	
9	1CC-E7632-00	重锤 WEIGHT	6	6	
10	1CC-E7623-00	凸轮 CAM	1	1	
11	1CC-E7653-00	滑块 SLIDER	3	3	
12	90387-16816	轴套 COLLAR	1	1	
13	1CC-E7641-00	V型皮带 V-BELT	1	1	
14	1CC-E7611-00	主固定槽 SHEAVE, PRIMARY FIXED	1	1	
15	90214-14804	爪形垫圈 WASHER, CLAW	1	1	
16	1CC-E5657-00	单向离合器 CLUTCH, ONEWAY	1	1	
17	90208-12050	弹性挡圈 WASHER, CONICAL SPRING	1	1	
18	95302-12700	螺母 NUT	1	1	
19	1CC-E7602-00	副槽轮组合 SECONDARY SHEAVE ASSY	1	1	
20	1CC-E6620-00	离合器载架组合 CLUTCH CARRIER ASSY	1	1	
21	1CC-E6626-00	离合器重锤弹簧 1 SPRING, CLUTCH WEIGHT 1	3	3	
22	1CC-E7660-00	副固定槽轮组合 SECONDARY FIXED SHEAVE COMP.	1	1	
23	1CC-E7670-00	副滑轮 SECONDARY SLIDING SHEAVE	1	1	
24	93109-33803	油封 OIL SEAL	2	2	
25	93210-36800	O型环 O-RING	2	2	
26	1CC-E7664-00	导承销 PIN, GUIDE	2	2	
27	90501-43804	压簧 SPRING, COMPRESSION	1	1	

FIG. 11 离合器

CLUTCH

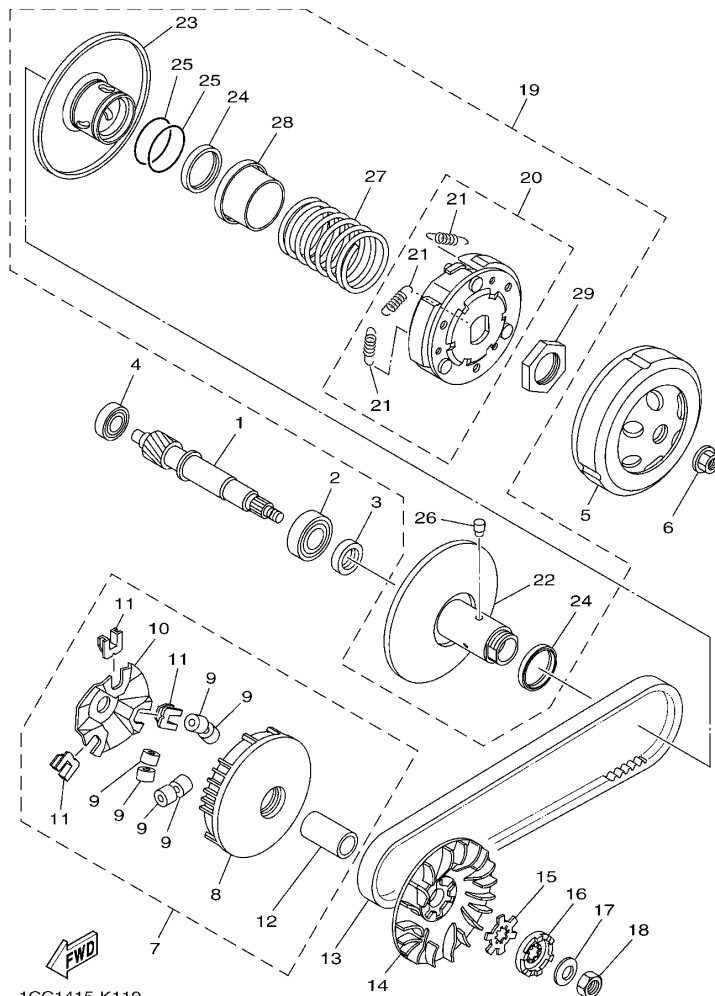

1CC1415-K110

参照 号码	零件号码 PART NO.	零件名称 DESCRIPTION	4SD9	4SDA		备注 REMARKS
28	1CC-E7684-00	.辅助弹簧座 .SEAT, SECONDARY SPRING	1	1		
29	90170-28802	.螺母 .NUT	1	1		

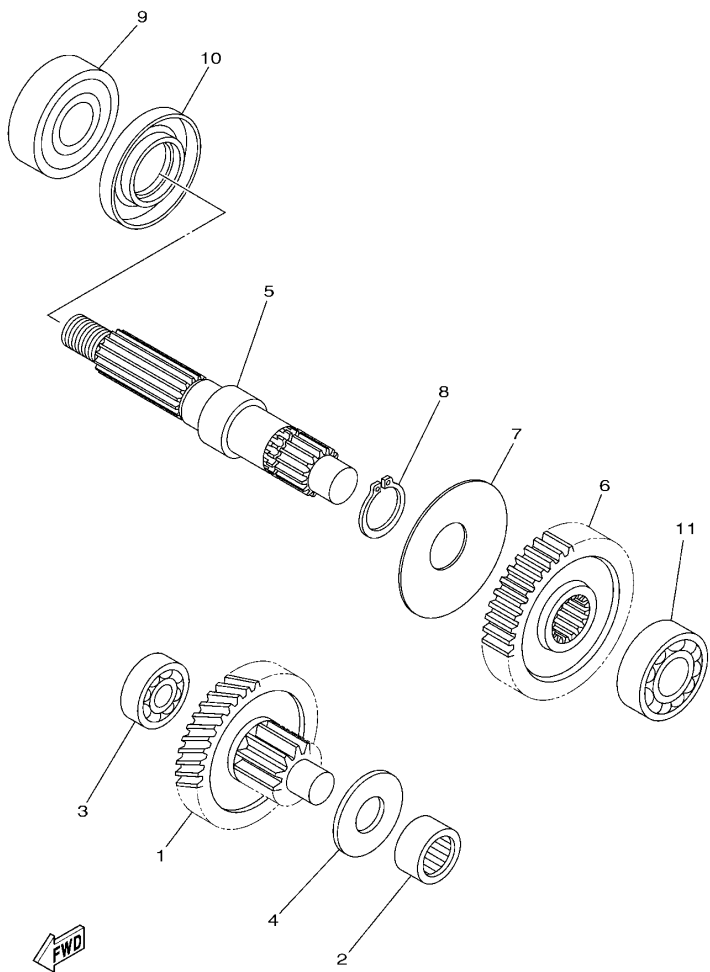

1CC1415-K120

FIG. 12 传动

TRANSMISSION

参照 号码	零件号码 PART NO.	零件名称 DESCRIPTION	4S09	4S0A			备注 REMARKS
1	1CC-E7410-00	主轮轴组 MAIN AXLE COMP. (13T/47T)	1	1			
2	93311-315X0	轴承 BEARING	1	1			
3	93306-200X0	轴承 BEARING	1	1			
4	90201-15816	平垫圈 WASHER, PLATE	1	1			
5	1CC-E7421-00	驱动轴 AXLE, DRIVE	1	1			
6	1CC-E7211-00	一档从动齿轮 GEAR, 1ST WHEEL (39T)	1	1			
7	90208-21802	弹性挡圈 WASHER, CONICAL SPRING	1	1			
8	93410-20823	卡环 CIRCLIP	1	1			
9	93306-204XC	轴承 BEARING	1	1			
10	93102-26852	油封 OIL SEAL	1	1			
11	93306-253Y0	轴承 BEARING	1	1			

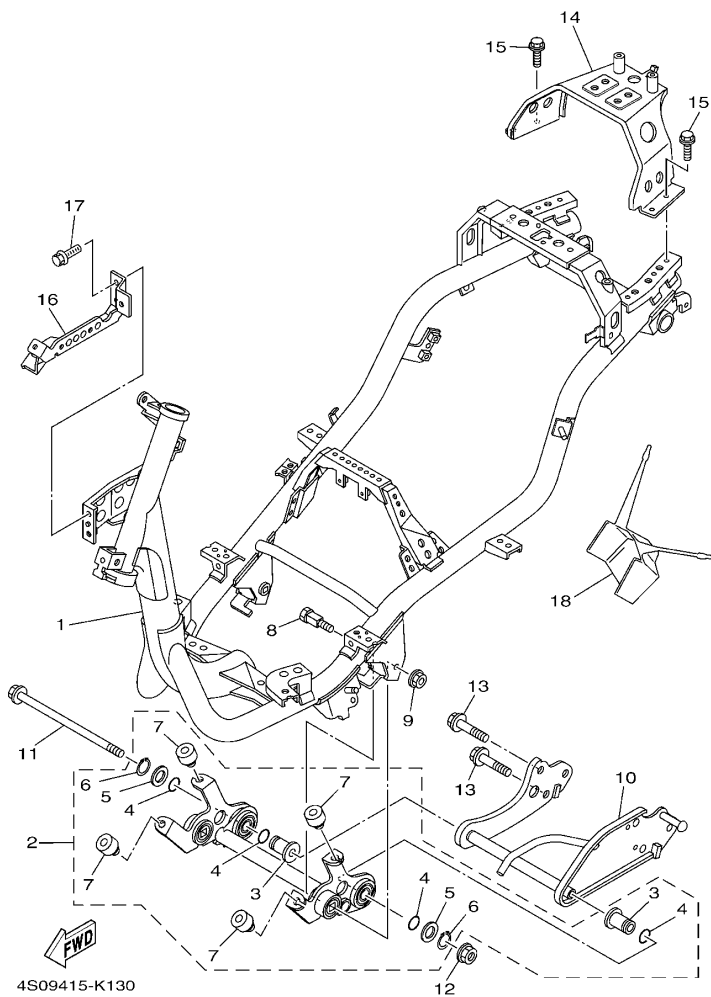

4S09415-K130

FIG. 13 车架

FRAME

参照 号码	零件号码 PART NO.	零件名称 DESCRIPTION	4S09	4S0A	备注 REMARKS
1	4S0-F1110-01	车架组合 FRAME COMP.	1	1	
2	4S0-X2142-10	发动机托架组合 2 ENGINE BRACKET COMP.2	1	1	
3	5WG-E5317-01	发动机机架衬套 .SPACER, ENGINE MOUNT	2	2	
4	93210-15639	.O型环 .O-RING	4	4	
5	90201-17804	.平垫圈 .WASHER, PLATE	2	2	
6	99009-17400	.卡环 .CIRCLIP	2	2	
7	5WG-F118W-00	.限位板 .STOPPER	4	4	
8	5WG-F1481-01	发动机装配螺栓 1 BOLT, ENGINE MOUNTING 1	2	2	
9	95602-10200	自锁螺母 NUT, U FLANGE	2	2	
10	4S0-F1410-20	发动机托架组合 ENGINE BRACKET COMP.	1	1	
11	5WG-F1482-01	发动机装配螺栓 2 BOLT, ENGINE MOUNTING 2	1	1	
12	95602-10200	自锁螺母 NUT, U FLANGE	1	1	
13	95812-10030	凸缘螺栓 BOLT, FLANGE	2	2	
14	5WG-F116F-11	后支承 STAY, REAR	1	1	
15	95802-06014	凸缘螺栓 BOLT, FLANGE	4	4	
16	4S0-F1274-00	电子点火器托架 BRACKET, C.D.I. UNIT	1	1	
17	95802-06012	凸缘螺栓 BOLT, FLANGE	2	2	
18	5WG-F1521-00	前防护板挡板 FLAP, FRONT FENDER	1	1	

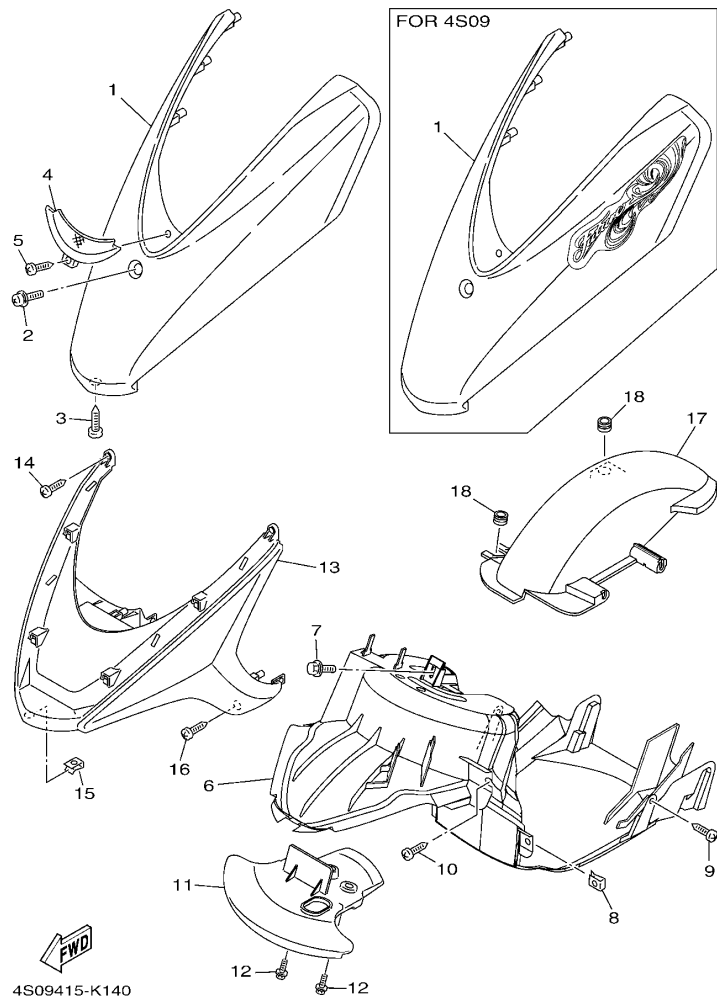

FIG. 14 挡泥板

FENDER

参照 号码	零件号码 PART NO.	零件名称 DESCRIPTION	4S09	4S0A	备注 REMARKS
1	4S0-X2150-10-PA	前挡泥板 FRONT FENDER ASSY	1		UR 深鸡尾红色 2 车用 UR FOR DRC2
	4S0-X2150-10-PB	前挡泥板 FRONT FENDER ASSY	1		UR 特暗蓝 4 车用 UR FOR VDBC4
	4S0-X2150-10-P2	前挡泥板 FRONT FENDER ASSY	1		UR 金属黑色车用 UR FOR SMX
	4S0-X2150-10-P9	前挡泥板 FRONT FENDER ASSY	1		UR 浅蓝鸡尾白色 1 车用 UR FOR BWC1
	5WG-F1511-01-P1	前挡泥板 FENDER, FRONT		1	UR 银 3 车用 UR FOR S3
	5WG-F1511-01-UG	前挡泥板 FENDER, FRONT		1	UR 棕色车用 UR FOR IPB
	5WG-F1511-01-P2	前挡泥板 FENDER, FRONT		1	UR 金属黑色车用 UR FOR SMX
	5WG-F1511-01-P9	前挡泥板 FENDER, FRONT		1	UR 浅蓝鸡尾白色 1 车用 UR FOR BWC1
2	90159-06811	带垫螺钉 SCREW, WITH WASHER	1	1	
3	97702-50012	自攻螺钉 SCREW, TAPPING	1	1	
4	5WG-F1523-00	面板 1 PLATE 1	1	1	
5	97702-50016	自攻螺钉 SCREW, TAPPING	1	1	
6	5WG-F1552-04	内防护板 FENDER, INNER	1	1	
7	90119-068A3	带垫螺栓 BOLT, WITH WASHER	1	1	
8	90183-05818	弹性螺母 NUT, SPRING	2	2	
9	97702-50012	自攻螺钉 SCREW, TAPPING	2	2	
10	97702-50016	自攻螺钉 SCREW, TAPPING	2	2	
11	5WG-F1553-00	内防护板 2 FENDER, INNER 2	1	1	
12	90119-06157	带垫螺栓 BOLT, WITH WASHER	2	2	
13	5WG-F1519-01-P9	防护板嵌条 MOLE, FENDER	1		UR 深鸡尾红色 2 车用 UR FOR DRC2
	5WG-F1519-01-PA	防护板嵌条 MOLE, FENDER	1		UR 特暗蓝 4 车用 UR FOR VDBC4
	5WG-F1519-01-P2	防护板嵌条 MOLE, FENDER	1		UR 金属黑色车用 UR FOR SMX
	5WG-F1519-01-P8	防护板嵌条 MOLE, FENDER	1		UR 浅蓝鸡尾白色 1 车用 UR FOR BWC1
	5WG-F1519-01-C1	防护板嵌条 MOLE, FENDER		1	黑灰 DGM1
14	97702-50016	自攻螺钉 SCREW, TAPPING	2	2	
15	90183-05818	弹性螺母 NUT, SPRING	1	1	
16	97702-50012	自攻螺钉 SCREW, TAPPING	2	2	

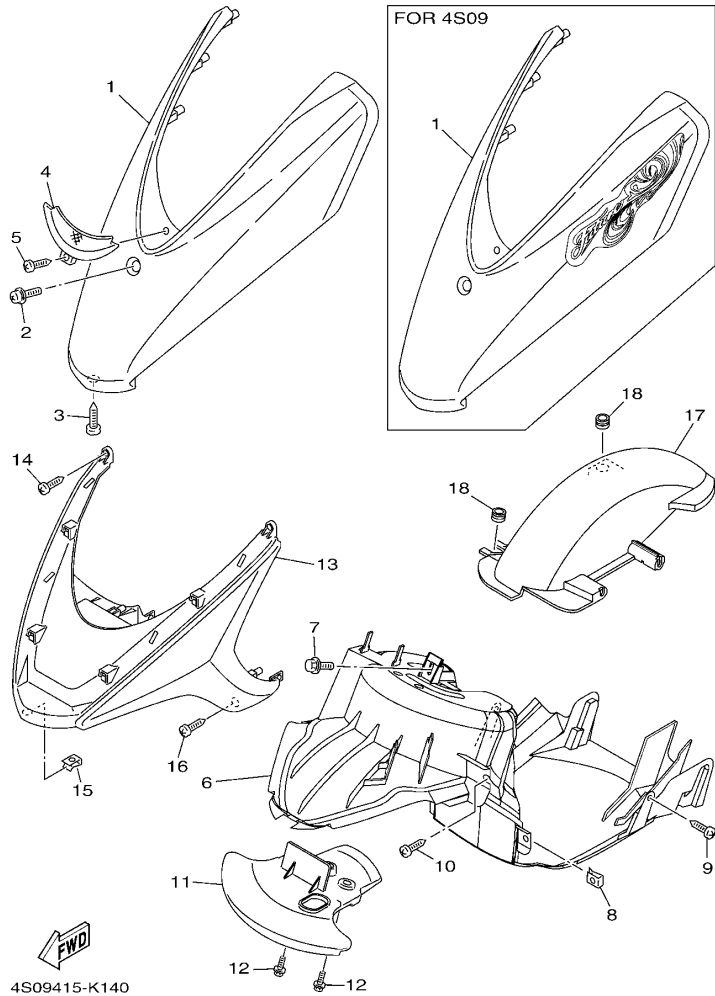
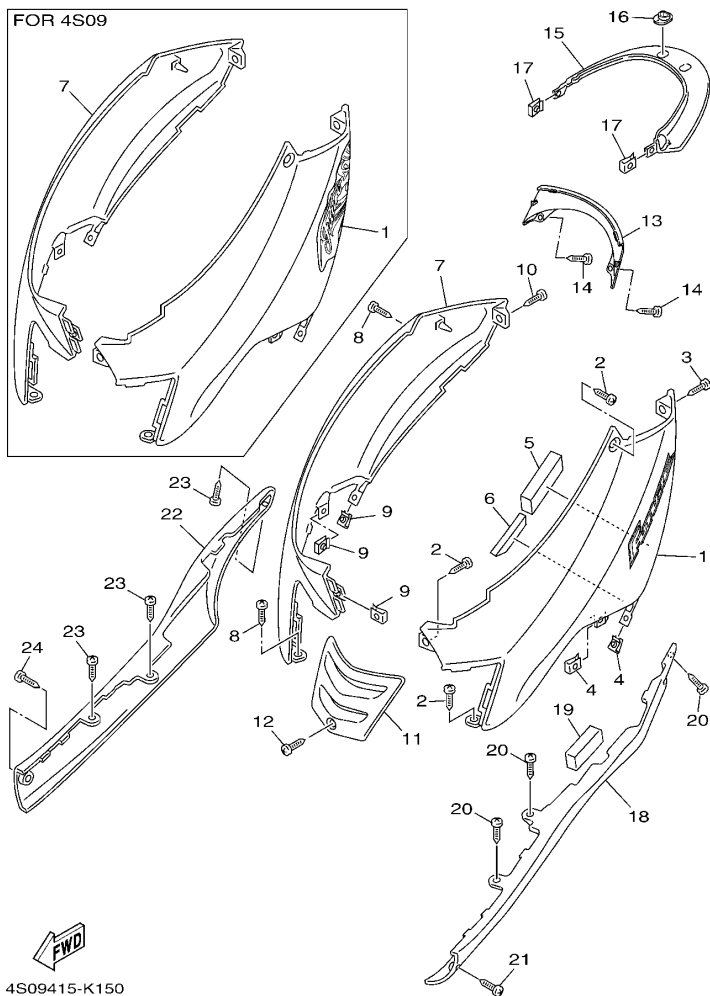

FIG. 14 挡泥板

FENDER

参照 号码	零件号码 PART NO.	零件名称 DESCRIPTION	4S09	4S0A			备注 REMARKS
17	4S0-F1611-00	后挡泥板 FENDER, REAR	1	1			
18	90480-12803	橡胶垫 GROMMET	2	2			



4S09415-K150

FIG. 15 侧盖

SIDE COVER

参照 号码	零件号码 PART NO.	零件名称 DESCRIPTION	4S09	4S0A	备注 REMARKS
1	4S0-X2171-21-PB	侧盖 1 COVER, SIDE 1	1		UR 深鸡尾红色 2 车用 UR FOR DRC2
	4S0-X2171-21-PC	侧盖 1 COVER, SIDE 1	1		UR 特暗蓝 4 车用 UR FOR VDBC4
	4S0-X2171-21-P0	侧盖 1 COVER, SIDE 1	1		UR 金属黑色车用 UR FOR SMX
	4S0-X2171-21-P9	侧盖 1 COVER, SIDE 1	1		UR 浅蓝鸡尾白色 1 车用 UR FOR BWC1
	4S0-X2171-31-P3	侧盖 1 COVER, SIDE 1		1	UR 银 3 车用 UR FOR S3
	4S0-X2171-31-UG	侧盖 1 COVER, SIDE 1		1	UR 棕色车用 UR FOR IPB
	4S0-X2171-31-P0	侧盖 1 COVER, SIDE 1		1	UR 金属黑色车用 UR FOR SMX
	4S0-X2171-31-P9	侧盖 1 COVER, SIDE 1		1	UR 浅蓝鸡尾白色 1 车用 UR FOR BWC1
2	97702-50012	自攻螺钉 SCREW, TAPPING	3	3	
3	97702-50016	自攻螺钉 SCREW, TAPPING	1	1	
4	90183-05818	弹性螺母 NUT, SPRING	2	2	
5	5WG-F1717-00	侧罩减震 DAMPER	1	1	
6	5WG-F1746-00	减震垫 DAMPER	1	1	
7	4S0-X2172-21-PB	侧盖 2 COVER, SIDE 2	1		UR 深鸡尾红色 2 车用 UR FOR DRC2
	4S0-X2172-21-PC	侧盖 2 COVER, SIDE 2	1		UR 特暗蓝 4 车用 UR FOR VDBC4
	4S0-X2172-21-P0	侧盖 2 COVER, SIDE 2	1		UR 金属黑色车用 UR FOR SMX
	4S0-X2172-21-P9	侧盖 2 COVER, SIDE 2	1		UR 浅蓝鸡尾白色 1 车用 UR FOR BWC1
	4S0-X2172-31-P3	侧盖 2 COVER, SIDE 2		1	UR 银 3 车用 UR FOR S3
	4S0-X2172-31-UG	侧盖 2 COVER, SIDE 2		1	UR 棕色车用 UR FOR IPB
	4S0-X2172-31-P0	侧盖 2 COVER, SIDE 2		1	UR 金属黑色车用 UR FOR SMX
	4S0-X2172-31-P9	侧盖 2 COVER, SIDE 2		1	UR 浅蓝鸡尾白色 1 车用 UR FOR BWC1
8	97702-50012	自攻螺钉 SCREW, TAPPING	2	2	
9	90183-05818	弹性螺母 NUT, SPRING	3	3	
10	97702-50016	自攻螺钉 SCREW, TAPPING	1	1	
11	5WG-F1731-00-PB	侧盖 3 COVER, SIDE 3	1		UR 深鸡尾红色 2 车用 UR FOR DRC2
	5WG-F1731-00-PC	侧盖 3 COVER, SIDE 3	1		UR 特暗蓝 4 车用 UR FOR VDBC4
	5WG-F1731-00-P2	侧盖 3 COVER, SIDE 3	1	1	UR 金属黑色车用 UR FOR SMX

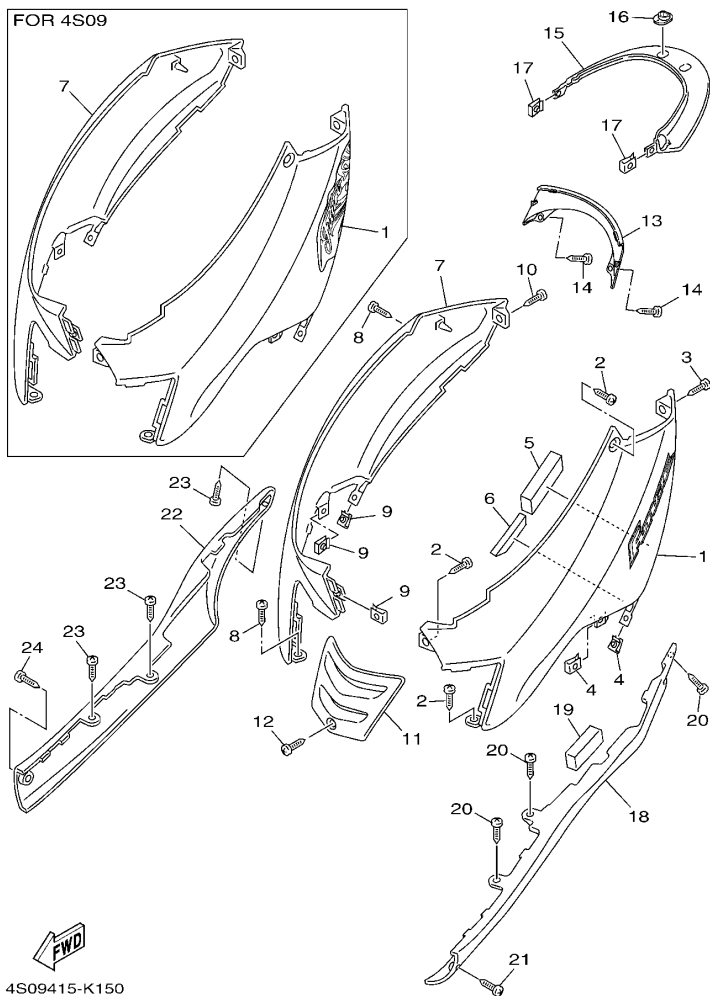

4S09415-K150

FIG. 15 侧盖

SIDE COVER

参照 号码	零件号码 PART NO.	零件名称 DESCRIPTION	4S09	4S0A	备注 REMARKS
11	5WG-F1731-00-P9	侧盖 3 COVER, SIDE 3	1	1	UR 浅蓝鸡尾白色 1 车用 UR FOR BWC1
	5WG-F1731-00-P1	侧盖 3 COVER, SIDE 3		1	UR 银 3 车用 UR FOR S3
	5WG-F1731-00-UG	侧盖 3 COVER, SIDE 3		1	UR 棕色车用 UR FOR IPB
12	97702-50012	自攻螺钉 SCREW, TAPPING	1	1	
13	5WG-F1741-00-PB	侧盖 4 COVER, SIDE 4	1		UR 深鸡尾红色 2 车用 UR FOR DRC2
	5WG-F1741-00-PC	侧盖 4 COVER, SIDE 4	1		UR 特暗蓝 4 车用 UR FOR VDBC4
	5WG-F1741-00-P2	侧盖 4 COVER, SIDE 4	1	1	UR 金属黑色车用 UR FOR SMX
	5WG-F1741-00-P9	侧盖 4 COVER, SIDE 4	1	1	UR 浅蓝鸡尾白色 1 车用 UR FOR BWC1
	5WG-F1741-00-P1	侧盖 4 COVER, SIDE 4		1	UR 银 3 车用 UR FOR S3
	5WG-F1741-00-UG	侧盖 4 COVER, SIDE 4		1	UR 棕色车用 UR FOR IPB
14	97702-50012	自攻螺钉 SCREW, TAPPING	2	2	
15	5WG-F171E-00-PB	侧盖 5 COVER, SIDE 5	1		UR 深鸡尾红色 2 车用 UR FOR DRC2
	5WG-F171E-00-PC	侧盖 5 COVER, SIDE 5	1		UR 特暗蓝 4 车用 UR FOR VDBC4
	5WG-F171E-00-P2	侧盖 5 COVER, SIDE 5	1	1	UR 金属黑色车用 UR FOR SMX
	5WG-F171E-00-P9	侧盖 5 COVER, SIDE 5	1	1	UR 浅蓝鸡尾白色 1 车用 UR FOR BWC1
	5WG-F171E-00-P1	侧盖 5 COVER, SIDE 5		1	UR 银 3 车用 UR FOR S3
	5WG-F171E-00-UG	侧盖 5 COVER, SIDE 5		1	UR 棕色车用 UR FOR IPB
16	5WG-F1773-00	固定套 GROMMET	2	2	
17	90183-05818	弹性螺母 NUT, SPRING	2	2	
18	5WG-F171L-02-P2	侧盖嵌条 1 MOLE, SIDE COVER 1	1		UR 深鸡尾红色 2 车用 UR FOR DRC2
	5WG-F171L-02-PC	侧盖嵌条 1 MOLE, SIDE COVER 1	1		UR 特暗蓝 4 车用 UR FOR VDBC4
	5WG-F171L-02-P9	侧盖嵌条 1 MOLE, SIDE COVER 1	1		UR 金属黑色车用 UR FOR SMX
	5WG-F171L-02-P8	侧盖嵌条 1 MOLE, SIDE COVER 1	1		UR 浅蓝鸡尾白色 1 车用 UR FOR BWC1
	5WG-F171L-02-C1	侧盖嵌条 1 MOLE, SIDE COVER 1		1	黑灰 DGM1
19	5MH-F1717-00	侧罩减震 DAMPER	1	1	
20	97702-50012	自攻螺钉 SCREW, TAPPING	3	3	
21	97702-50016	自攻螺钉 SCREW, TAPPING	1	1	

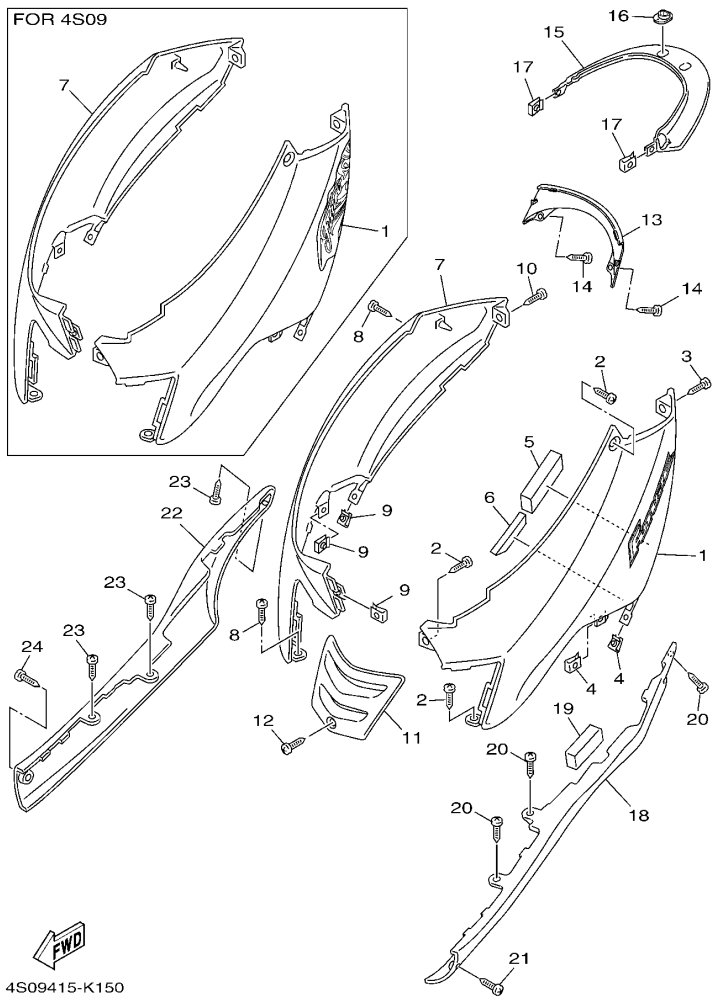

FIG. 15 侧盖

SIDE COVER

参照 号码	零件号码 PART NO.	零件名称 DESCRIPTION	4S09	4S0A	备注 REMARKS
22	5WG-F171M-02-P2	侧盖嵌条 2 MOLE, SIDE COVER 2	1		UR 深鸡尾红色 2 车用 UR FOR DRC2
	5WG-F171M-02-PC	侧盖嵌条 2 MOLE, SIDE COVER 2	1		UR 特暗蓝 4 车用 UR FOR VDBC4
	5WG-F171M-02-P9	侧盖嵌条 2 MOLE, SIDE COVER 2	1		UR 金属黑色车用 UR FOR SMX
	5WG-F171M-02-P8	侧盖嵌条 2 MOLE, SIDE COVER 2	1		UR 浅蓝鸡尾白色 1 车用 UR FOR BWC1
	5WG-F171M-02-C1	侧盖嵌条 2 MOLE, SIDE COVER 2		1	黑灰 DGM1
23	97702-50012	自攻螺钉 SCREW, TAPPING	3	3	
24	97702-50016	自攻螺钉 SCREW, TAPPING	1	1	

FIG. 16 后臂·悬挂

REAR ARM & SUSPENSION

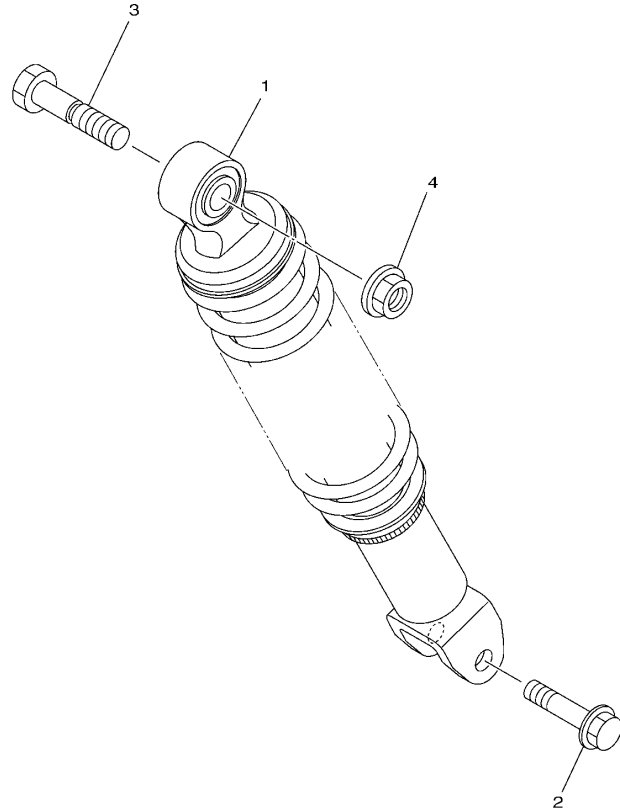

参照 号码	零件号码 PART NO.	零件名称 DESCRIPTION	4S09	4S0A			备注 REMARKS
1	4S5-F2210-00	后减震器组合 SHOCK ABSORBER ASSY, REAR	1	1			
2	90105-08861	凸缘螺栓 BOLT, FLANGE	1	1			
3	90101-10809	螺栓 BOLT	1	1			
4	95702-10500	螺母 NUT, FLANGE	1	1			

FIG. 17 前叉(鼓刹)

FRONT FORK FOR DRUM BRAKE

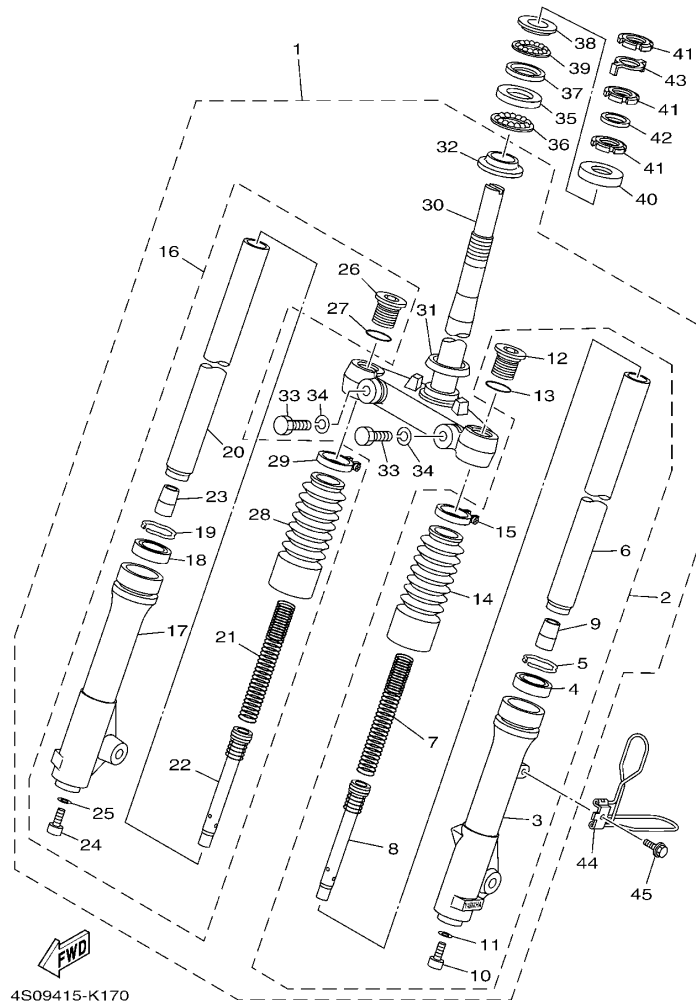

参照 号码	零件号码 PART NO.	零件名称 DESCRIPTION	4S09	4S0A		备注 REMARKS
1	4S0-F3100-02	前叉组合 FRONT FORK ASSY	1			
2	4S0-F3102-02	.前叉组合(左边) .FRONT FORK ASSY (L.H)	1			
3	4S0-F3126-01	.外管 1 .TUBE, OUTER (LEFT)	1			
4	4GU-F3145-00	.油封 .OIL SEAL	1			
5	5AP-F3153-00	.扣环 .RING, SNAP	1			
6	5WG-F3110-00	.内管组件 1 .INNER TUBE COMP.1	1			
7	5WG-F3141-00	.前叉弹簧 .SPRING, FRONT FORK	1			
8	5WG-F3170-00	.柄管缸套 .CYL,COMP.	1			
9	4GU-F3173-01	.锥形主轴 .SPINDLE, TAPER	1			
10	5LK-F3356-01	.螺栓 2 .BOLT 2	1			
11	4TU-F3479-00	.衬垫 .GASKET	1			
12	4KL-F3111-01	.顶盖螺栓 .BOLT, CAP	1			
13	5AP-F3147-00	.O型环 .O-RING	1			
14	4KL-F3191-10	.保护罩 .BOOT	1			
15	4KL-F3192-11	.带箍 .BAND	1			
16	4S0-F3103-02	.前叉组合(右边) .FRONT FORK ASSY (R.H)	1			
17	4S0-F3136-00	.外管 2 .TUBE, OUTER (RIGHT)	1			
18	4GU-F3145-00	.油封 .OIL SEAL	1			
19	5AP-F3153-00	.扣环 .RING, SNAP	1			
20	5WG-F3110-00	.内管组件 1 .INNER TUBE COMP.1	1			
21	5WG-F3141-00	.前叉弹簧 .SPRING, FRONT FORK	1			
22	5WG-F3170-00	.柄管缸套 .CYL,COMP.	1			
23	4GU-F3173-01	.锥形主轴 .SPINDLE, TAPER	1			
24	5LK-F3356-01	.螺栓 2 .BOLT 2	1			
25	4TU-F3479-00	.衬垫 .GASKET	1			
26	4KL-F3111-01	.顶盖螺栓 .BOLT, CAP	1			
27	5AP-F3147-00	.O型环 .O-RING	1			

FIG. 17 前叉(鼓刹)

FRONT FORK FOR DRUM BRAKE

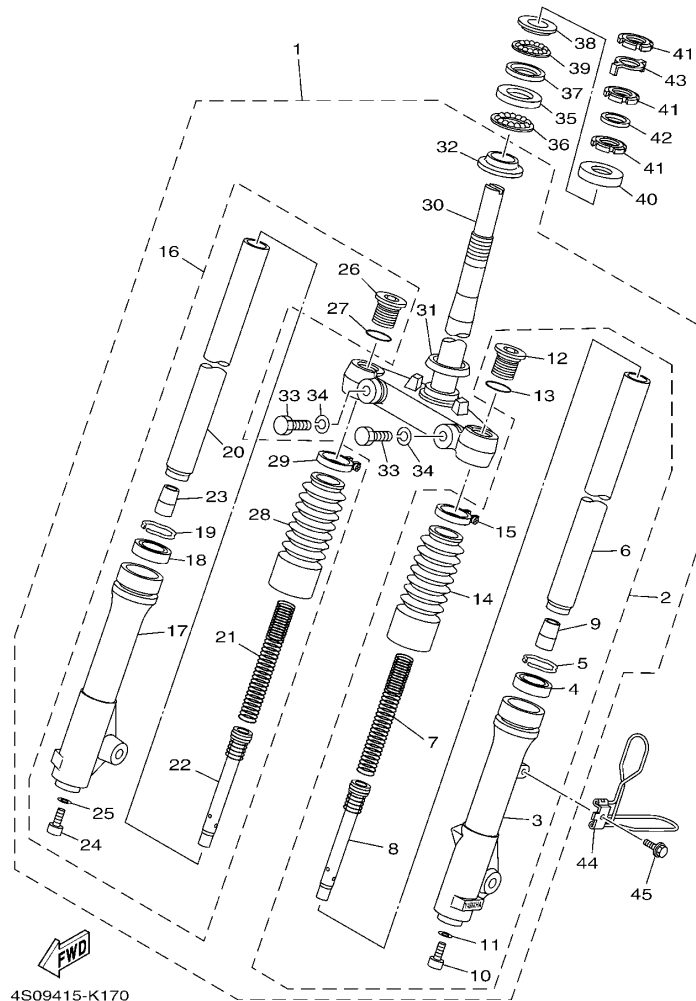

4S09415-K170

参照 号码	零件号码 PART NO.	零件名称 DESCRIPTION	4S09	4S0A			备注 REMARKS
28	4KL-F3191-10	. 保护罩 .BOOT	1				
29	4KL-F3192-11	. 带箍 .BAND	1				
30	5WG-F3340-00	. 底托架组 .UNDER BRACKET COMP.	1				
31	4GU-F3462-00	. 方向柱密封圈 .SEAL, DUST	1				
32	4FP-F3411-10	. 滚珠座圈 1 .RACE, BALL 1	1				
33	4RT-F3346-01	. 螺栓 1 .BOLT 1	2				
34	94101-12302	. 轮胎 .WASHER, SPRING	2				
35	4KL-F3412-20	. 滚珠座圈 2 RACE, BALL 2	1				
36	5WG-F341E-00	. 保持架 RETAINER, BALL BEARING	1				
37	4KL-F3412-30	. 滚珠座圈 2 RACE, BALL 2	1				
38	4KL-F3411-00	. 滚珠座圈 1 RACE, BALL 1	1				
39	5WG-F341E-10	. 保持架 RETAINER, BALL BEARING	1				
40	5MH-F3416-01	. 滚珠座圈盖 2 COVER, BALL RACE 2	1				
41	90179-25810	. 螺母 NUT	3				
42	90202-26142	. 平垫圈 WASHER, PLATE	1				
43	5WG-F3418-01	. 专用垫圈 WASHER, SPECIAL	1				
44	1CC-F3317-10	. 钢索支架 HOLDER, CABLE	1				
45	95802-06010	. 凸缘螺栓 BOLT, FLANGE	1				

FIG. 18 前叉(碟刹)

FRONT FORK FOR DISK BRAKE

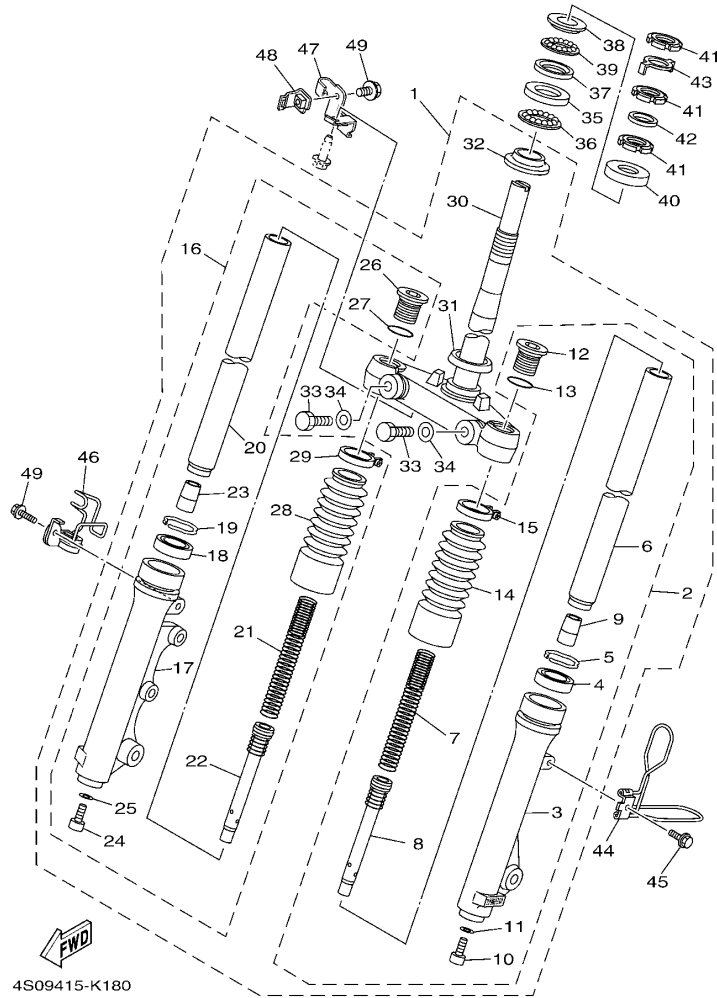

参照 号码	零件号码 PART NO.	零件名称 DESCRIPTION	4S09	4S0A	备注 REMARKS
1	4S0-F3100-12	前叉组合 FRONT FORK ASSY		1	
2	4S0-F3102-12	前叉组合(左边) FRONT FORK ASSY (L.H)		1	
3	4S0-F3126-11	外管 1 TUBE, OUTER (LEFT)		1	
4	4GU-F3145-00	油封 OIL SEAL		1	
5	5AP-F3153-00	扣环 RING, SNAP		1	
6	5WG-F3110-00	内管组件 1 INNER TUBE COMP.1		1	
7	4P7-F3141-10	前叉弹簧 SPRING, FRONT FORK		1	
8	4P7-F3170-10	前叉气缸组合 CYLINDER COMP., FRONT FORK		1	
9	4GU-F3173-01	锥形主轴 SPINDLE, TAPER		1	
10	5LK-F3356-01	螺栓 2 BOLT 2		1	
11	4TU-F3479-00	衬垫 GASKET		1	
12	4KL-F3111-01	顶盖螺栓 BOLT, CAP		1	
13	5AP-F3147-00	O型环 O-RING		1	
14	4KL-F3191-10	保护罩 BOOT		1	
15	4KL-F3192-11	带箍 BAND		1	
16	4S0-F3103-12	前叉组合(右边) FRONT FORK ASSY (R.H)		1	
17	4S0-F3136-10	外管 2 TUBE, OUTER (RIGHT)		1	
18	4GU-F3145-00	油封 OIL SEAL		1	
19	5AP-F3153-00	扣环 RING, SNAP		1	
20	5WG-F3110-00	内管组件 1 INNER TUBE COMP.1		1	
21	4P7-F3141-10	前叉弹簧 SPRING, FRONT FORK		1	
22	4P7-F3170-10	前叉气缸组合 CYLINDER COMP., FRONT FORK		1	
23	4GU-F3173-01	锥形主轴 SPINDLE, TAPER		1	
24	5LK-F3356-01	螺栓 2 BOLT 2		1	
25	4TU-F3479-00	衬垫 GASKET		1	
26	4KL-F3111-01	顶盖螺栓 BOLT, CAP		1	
27	5AP-F3147-00	O型环 O-RING		1	

FIG. 18 前叉(碟刹)

FRONT FORK FOR DISK BRAKE

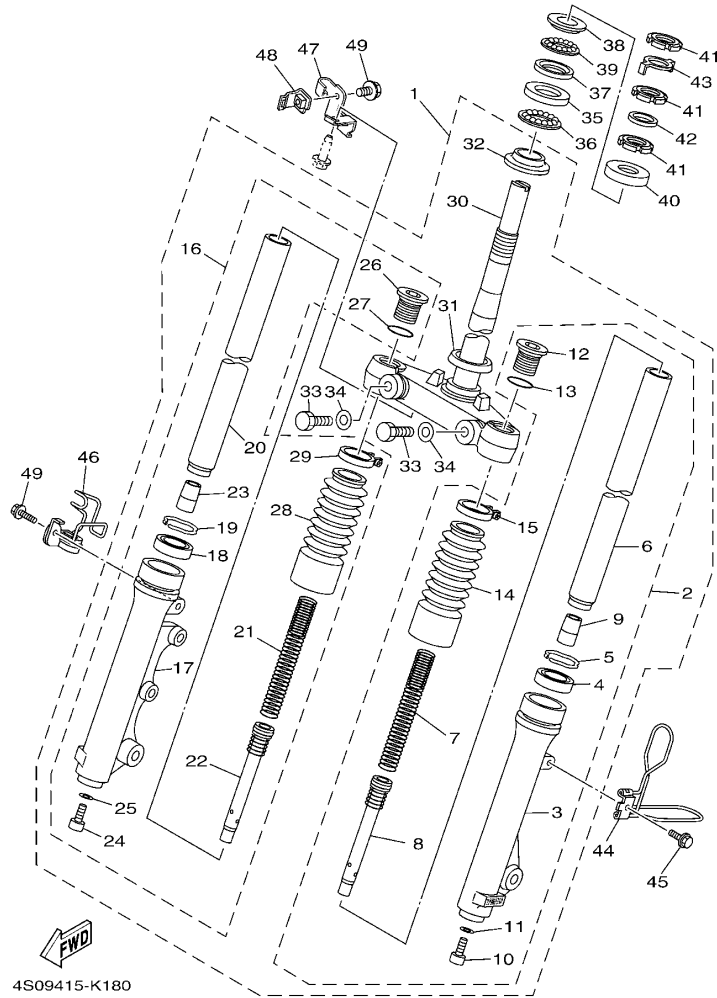

参照 号码	零件号码 PART NO.	零件名称 DESCRIPTION	4S09	4S0A	备注 REMARKS
28	4KL-F3191-10	. 保护罩 .BOOT		1	
29	4KL-F3192-11	. 带箍 .BAND		1	
30	4P7-F3340-10	. 底托架组 .UNDER BRACKET COMP.		1	
31	4GU-F3462-00	. 方向柱密封圈 .SEAL, DUST		1	
32	4FP-F3411-10	. 滚珠座圈 1 .RACE, BALL 1		1	
33	4RT-F3346-01	. 螺栓 1 .BOLT 1		2	
34	4P7-F3843-00	. 平垫圈 .WASHER, PLAIN		2	
35	4KL-F3412-00	滚珠座圈 2 RACE, BALL 2		1	
36	5WG-F341E-00	保持架 RETAINER, BALL BEARING		1	
37	4KL-F3412-30	滚珠座圈 2 RACE, BALL 2		1	
38	4KL-F3411-00	滚珠座圈 1 RACE, BALL 1		1	
39	5WG-F341E-10	保持架 RETAINER, BALL BEARING		1	
40	5MH-F3416-01	滚珠座圈盖 2 COVER, BALL RACE 2		1	
41	90179-25810	螺母 NUT		3	
42	90202-26142	平垫圈 WASHER, PLATE		1	
43	5WG-F3418-01	专用垫圈 WASHER, SPECIAL		1	
44	1CC-F3317-10	钢索支架 HOLDER, CABLE		1	
45	95802-06010	凸缘螺栓 BOLT, FLANGE		1	
46	4P7-F5875-01	制动软管支架 1 HOLDER, BRAKE HOSE 1		1	
47	5WG-F5887-02	制动软管支架 HOLDER, BRAKE HOSE		1	
48	5WG-F5886-01	制动软管支架 HOLDER, BRAKE HOSE		1	
49	95802-06012	凸缘螺栓 BOLT, FLANGE		2	

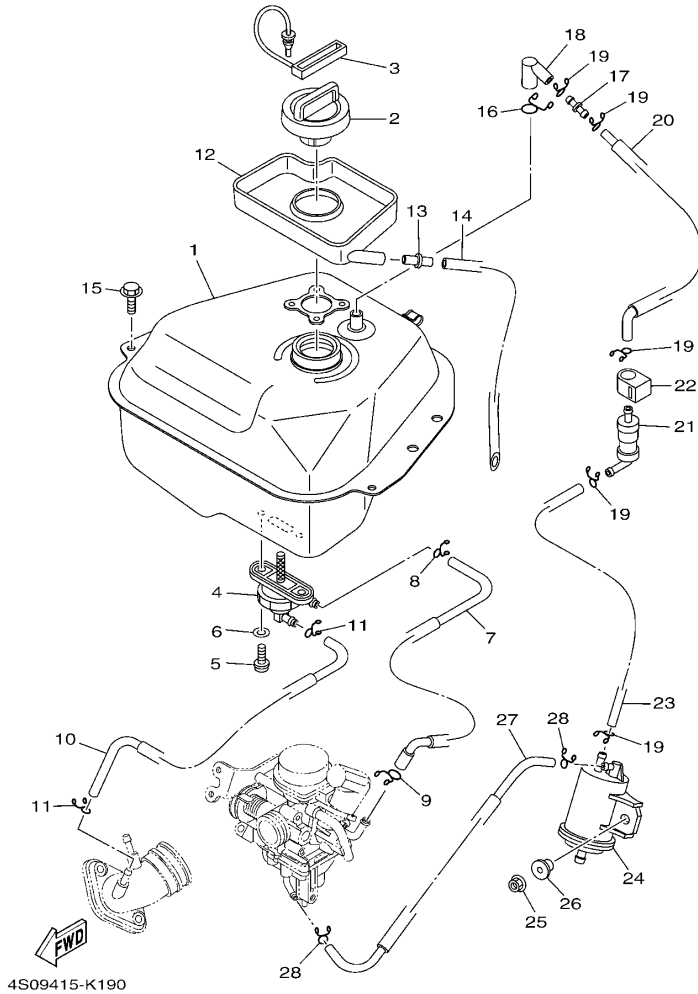

4S09415-K190

FIG. 19 油箱

FUEL TANK

参照 号码	零件号码 PART NO.	零件名称 DESCRIPTION	4S09	4S0A	备注 REMARKS
1	4S0-F4110-01	油箱组合 FUEL TANK COMP.	1	1	
2	4S0-F4610-01	油箱盖总成 CAP ASSY	1	1	
3	5WY-F4633-00	滚珠链 CHAIN, BALL	1	1	
4	5WG-F4500-01	燃油开关组合 1 FUEL COCK ASSY 1	1	1	
5	90149-06108	螺钉 SCREW	2	2	
6	90202-05193	平垫圈 WASHER, PLATE	2	2	
7	4S0-F4311-11	燃油管 1 PIPE, FUEL 1	1	1	
8	90467-09006	卡环 CLIP	1	1	
9	90467-10008	卡环 CLIP	1	1	
10	4S0-F4312-10	管 2 PIPE 2	1	1	
11	90467-08003	卡环 CLIP	2	2	
12	5WG-F414A-00	加油器盖 COVER, FILLER	1	1	
13	5WY-F1753-00	连接器轴节 BOSS, CONNECTOR	1	1	
14	91A11-07042	软管 TUBE, FLEXIBLE	1	1	
15	95802-06014	凸缘螺栓 BOLT, FLANGE	2	2	
16	90467-12802	卡环 CLIP	1	1	
17	4S0-F1753-00	连接器轴节 BOSS, CONNECTOR	1	1	
18	4S0-F4112-00	管 PIPE	1	1	
19	90467-09006	卡环 CLIP	5	5	
20	4S0-F4313-00	管 3 PIPE 3	1	1	
21	18C-F4180-00	滚动阀组合 ROLL OVER VALVE ASSY	1	1	
22	4S0-F4135-00	夹箍 1 CLAMP 1	1	1	
23	4S0-F4314-00	管 4 PIPE 4	1	1	
24	1CC-F4170-00	过滤缸总成 CANISTER ASSY	1	1	
25	95702-06500	螺母 NUT, FLANGE	1	1	
26	90387-068J2	轴套 COLLAR	1	1	
27	4S0-F4315-00	管 5 PIPE 5	1	1	

FIG. 19 油箱

FUEL TANK

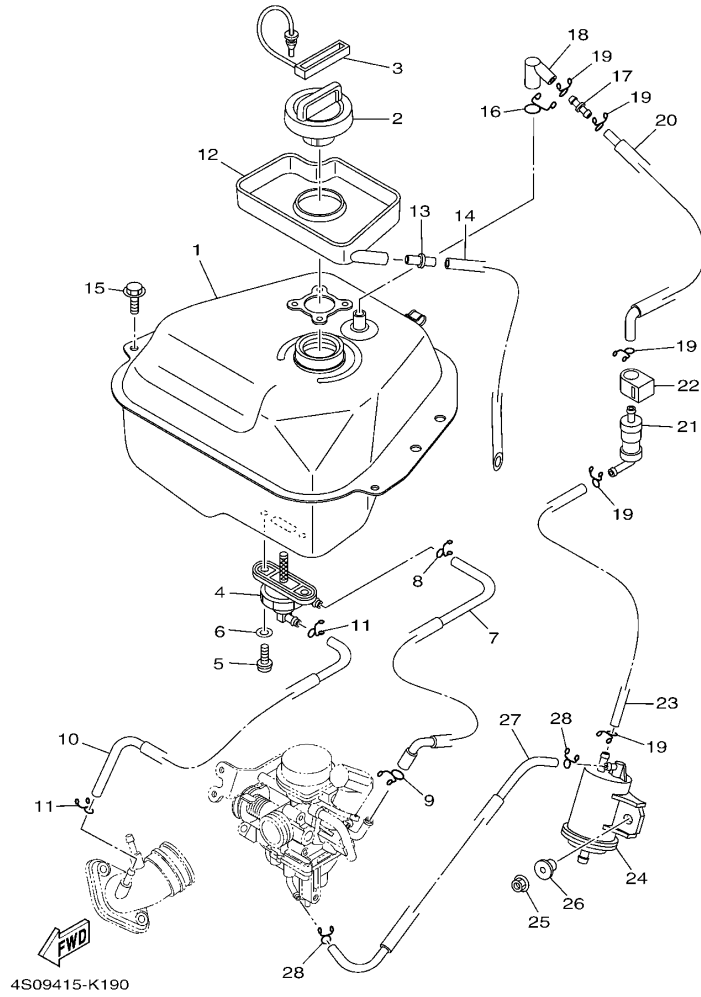

4S09415-K190

参照 号码	零件号码 PART NO.	零件名称 DESCRIPTION	4S09	4S0A		备注 REMARKS
28	90467-08003	卡环 CLIP	2	2		

FIG. 20 座位

SEAT

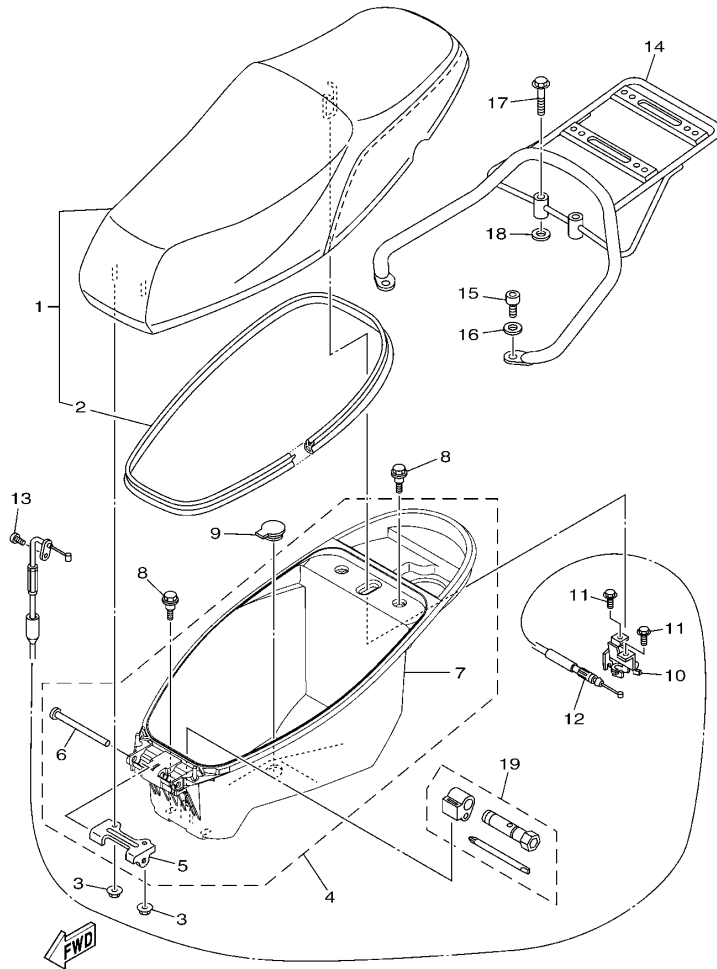

4S09415-K200

参照 号码	零件号码 PART NO.	零件名称 DESCRIPTION	4S09	4S0A			备注 REMARKS
1	5WG-F4730-03	双人座垫组合 DOUBLE SEAT ASSY	1	1			
2	5WG-F475M-00	.密封圈 .SEAL	1	1			
3	95702-06500	螺母 NUT, FLANGE	2	2			
4	4S0-X2473-20	置物箱组装总成 BOX 1 SUB ASSY	1	1			
5	5WG-F4726-00	.座位铰 .HINGE, SEAT	1	1			
6	90241-10801	.销 .PIN	1	1			
7	4S0-F473R-01	.箱 1 .BOX 1	1	1			
8	90109-06822	螺栓 BOLT	4	4			
9	5WY-F4742-00	塞 GROMMET	1	1			
10	5WY-F4780-01	座位锁装置组合 SEAT LOCK ASSY	1	1			
11	95802-06010	凸缘螺栓 BOLT, FLANGE	2	2			
12	5WG-F478E-01	车座锁钢索 CABLE, SEAT LOCK	1	1			
13	98502-05012	十字螺钉 SCREW, PAN HEAD	1	1			
14	4S0-F4842-00	后载架 CARRIER, REAR	1	1			
15	91312-08016	螺栓 BOLT	2	2			
16	90201-08043	平垫圈 WASHER, PLATE	2	2			
17	90119-08839	带垫螺栓 BOLT, WITH WASHER	2	2			
18	90201-08043	平垫圈 WASHER, PLATE	2	2			
19	4KL-F8100-01	随车工具 TOOL KIT	1	1			

FIG. 21 前轮(鼓刹)

FRONT WHEEL FOR DRUM BRAKE

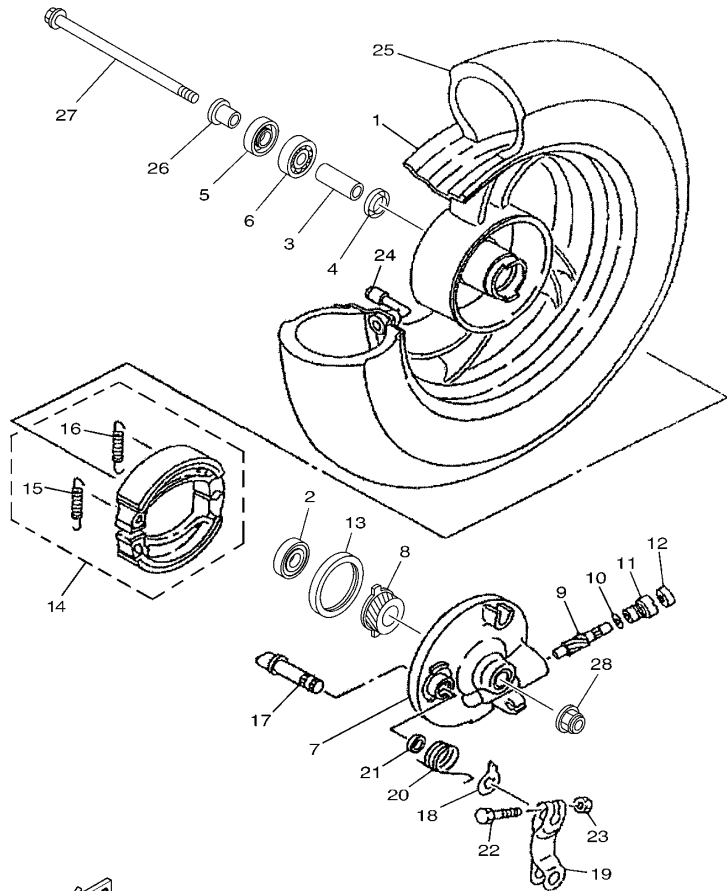

5WY3415-C200

参照 号码	零件号码 PART NO.	零件名称 DESCRIPTION	4S09	4S0A		备注 REMARKS
1	4KL-F5168-30-35	前压铸轮 CAST WHEEL, FRONT	1			银色 SL
2	93306-301XJ	轴承 BEARING	1			
3	90560-12138	衬套 SPACER	1			
4	5WG-F5315-00	凸缘衬套 FLANGE, SPACER	1			
5	93102-17853	油封 OIL SEAL	1			
6	93306-201X4	轴承 BEARING	1			
7	4KL-F5121-00-35	前制动盖 PLATE, BRAKE SHOE	1			银色 SL
8	5WG-F5135-00	主驱动齿轮 GEAR, DRIVE	1			
9	5WG-F5138-00	仪表齿轮 GEAR, METER	1			
10	90201-07076	平垫圈 WASHER, PLATE	1			
11	4KL-F5136-00	衬套 BUSH	1			
12	93104-07803	油封 OIL SEAL	1			
13	93106-47814	油封 OIL SEAL	1			
14	5WG-X2534-00	制动蹄块组合 BRAKE SHOE SET	1			
15	90506-12001	拉簧 .SPRING, TENSION	1			
16	90506-15001	拉簧 .SPRING, TENSION	1			
17	4KL-F5151-01	凸轮轴 CAMSHAFT	1			
18	4KL-F513A-01	指示器面板 PLATE, INDICATOR	1			
19	4KL-F5155-01	制动臂 1 LEVER, CAMSHAFT 1	1			
20	90508-26801	扭簧 SPRING, TORSION	1			
21	4KL-F5159-00	凸轮轴密封 SEAL, CAMSHAFT	1			
22	90101-06046	螺栓 BOLT	1			
23	95302-06600	螺母 NUT	1			
24	93900-00827	气门嘴 VALVE, RIM TR413	1			
25	94110-10810	轮胎 TIRE (100/90-10 C-922 56J TL)	1			CHENG SHIN
26	90387-128M1	轴套 COLLAR	1			
27	5WG-F5181-01	前轮轮轴 AXLE, WHEEL	1			

FIG. 21 前轮(鼓刹)

FRONT WHEEL FOR DRUM BRAKE

参照 号码	零件号码 PART NO.	零件名称 DESCRIPTION	4SD9	4SDA		备注 REMARKS
28	95602-12200	自锁螺母 NUT, SELF-LOCKING	1			

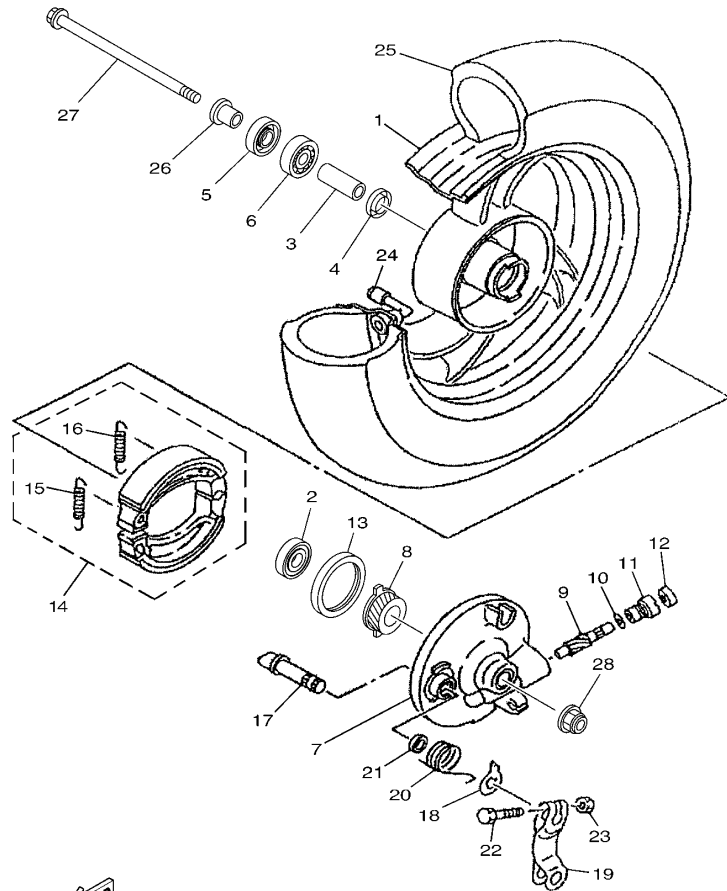

5WY3415-C200

FIG. 22 前轮(碟刹)

FRONT WHEEL FOR DISK BRAKE

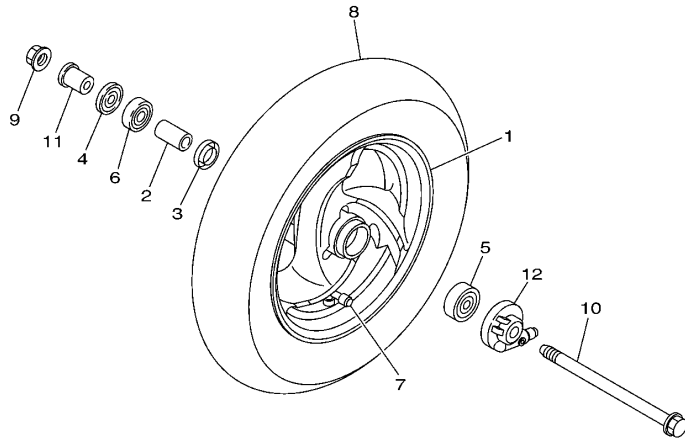

参照 号码	零件号码 PART NO.	零件名称 DESCRIPTION	4S09	4S0A	备注 REMARKS
1	4S5-F5168-01-35	前压铸轮 CAST WHEEL, FRONT		1	银色 SL
2	90387-12825	轴套 COLLAR		1	
3	5WG-F5315-00	凸缘衬套 FLANGE, SPACER		1	
4	93102-17853	油封 OIL SEAL		1	
5	93306-301XJ	轴承 BEARING		1	
6	93306-201X4	轴承 BEARING		1	
7	93900-00827	气门嘴 VALVE, RIM TR413		1	
8	94110-10810	轮胎 TIRE (100/90-10 C-922 56J TL)		1	CHENG SHIN
9	95602-12200	自锁螺母 NUT, SELF-LOCKING		1	
10	5WG-F5181-21	前轮轮轴 AXLE, WHEEL		1	
11	90387-125J1	轴套 COLLAR		1	
12	4P7-F5190-00	齿轮装置组合 GEAR UNIT ASSY		1	

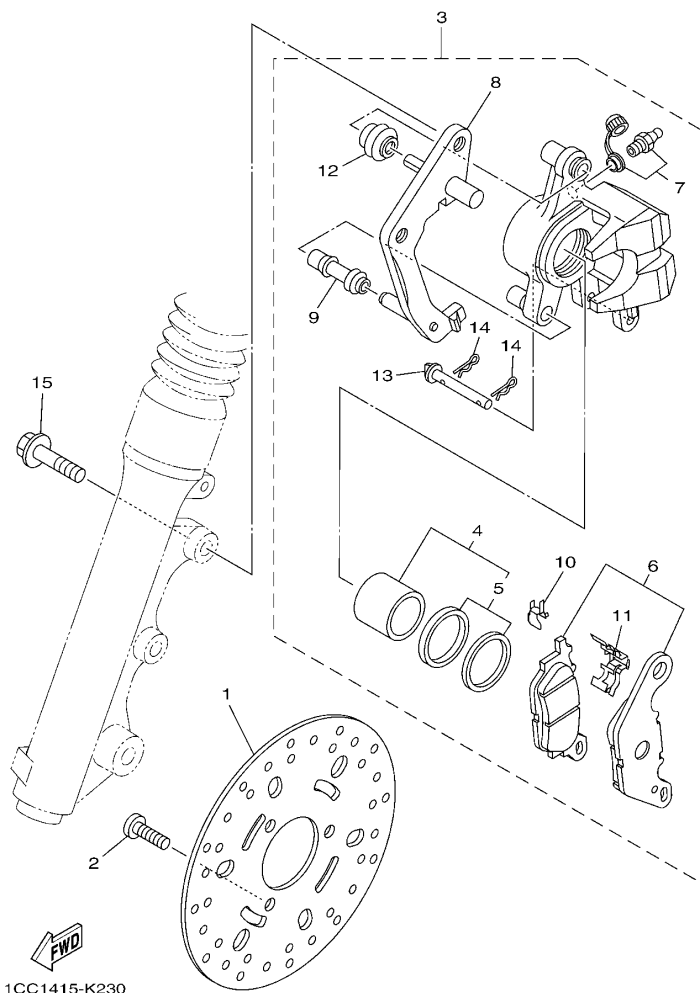

1CC1415-K230

FIG. 23 前制动器卡钳

FRONT BRAKE CALIPER

参照 号码	零件号码 PART NO.	零件名称 DESCRIPTION	4S09	4S0A		备注 REMARKS
1	5WG-F582U-20	制动盘 (右边) DISK, BRAKE (RIGHT)		1		
2	90149-08814	螺钉 SCREW		3		
3	3D9-F580U-01	制动器卡钳组合 (右边) CALIPER ASSY (RIGHT)		1		
4	4S5-W0057-00	. 卡钳活塞组合 . PISTON ASSY, CALIPER		1		
5	4S5-W0047-00	. 卡钳密封套件 . CALIPER SEAL KIT		1		
6	4S5-W0045-00	. 刹车片组合 . BRAKE PAD KIT		1		
7	4S5-W0048-01	. 带孔螺钉套件 . BLEED SCREW KIT		1		
8	4S5-F5921-01	. 支承托架 . BRACKET, SUPPORT		1		
9	4S5-F5937-00	. 保护罩 2 . BOOT 2		1		
10	4S5-F5939-00	. 扣片 . CLIP, PAD		1		
11	4S5-F5919-00	. 衬垫支承 . SUPPORT, PAD		1		
12	4S5-F5917-00	. 卡钳套 . BOOT, CALIPER		1		
13	4S5-F5924-01	. 刹车片销 . PIN, PAD		1		
14	4S5-F5925-00	. 卡环 . CLIP		2		
15	95022-10030	凸缘螺栓 BOLT, FLANGE		2		

FIG. 24 后轮

REAR WHEEL

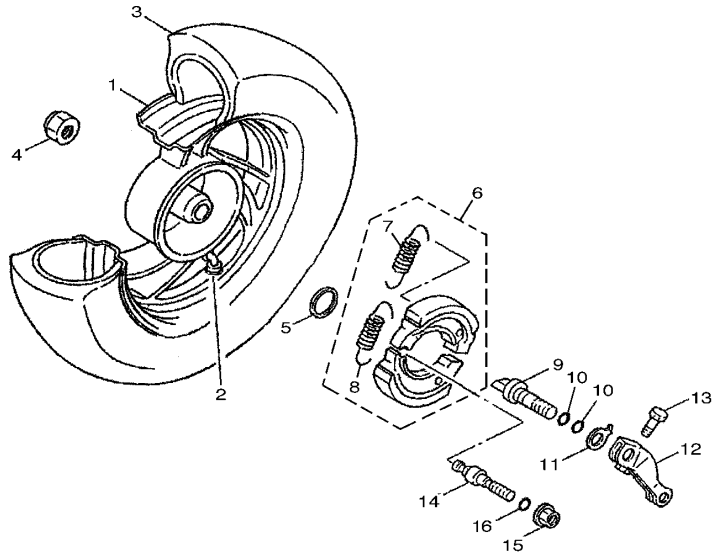

参照 号码	零件号码 PART NO.	零件名称 DESCRIPTION	4S09	4S0A			备注 REMARKS
1	4KL-F5338-10-35	后压铸轮 CAST WHEEL, REAR	1	1			银色 SL
2	93900-00827	气门嘴 VALVE, RIM TR413	1	1			
3	94110-10816	轮胎 TIRE (100/90-10 C940 56J TL)	1	1			CHENG SHIN
4	90185-14807	自锁螺母 NUT, SELF-LOCKING	1	1			
5	90201-20819	平垫圈 WASHER, PLATE	1	1			
6	5WG-X2534-00	制动蹄块组合 BRAKE SHOE SET	1	1			
7	90506-12001	拉簧 .SPRING, TENSION	1	1			
8	90506-15001	拉簧 .SPRING, TENSION	1	1			
9	5WY-F5351-01	凸轮轴 CAMSHAFT	1	1			
10	93210-09859	O型环 O-RING	2	2			
11	5WY-F533A-01	指示片 PLATE, INDICATOR	1	1			
12	5WY-F5355-01	制动臂 LEVER, CAMSHAFT	1	1			
13	90101-06046	螺栓 BOLT	1	1			
14	5WG-F5326-01	枢轴 PIN, PIVOT	1	1			
15	95702-10500	螺母 NUT, FLANGE	1	1			
16	93210-07890	O型环 O-RING	1	1			

FIG. 25 操纵手柄 钢索(鼓刹)

STEERING CABLE FOR DRUM BRAKE

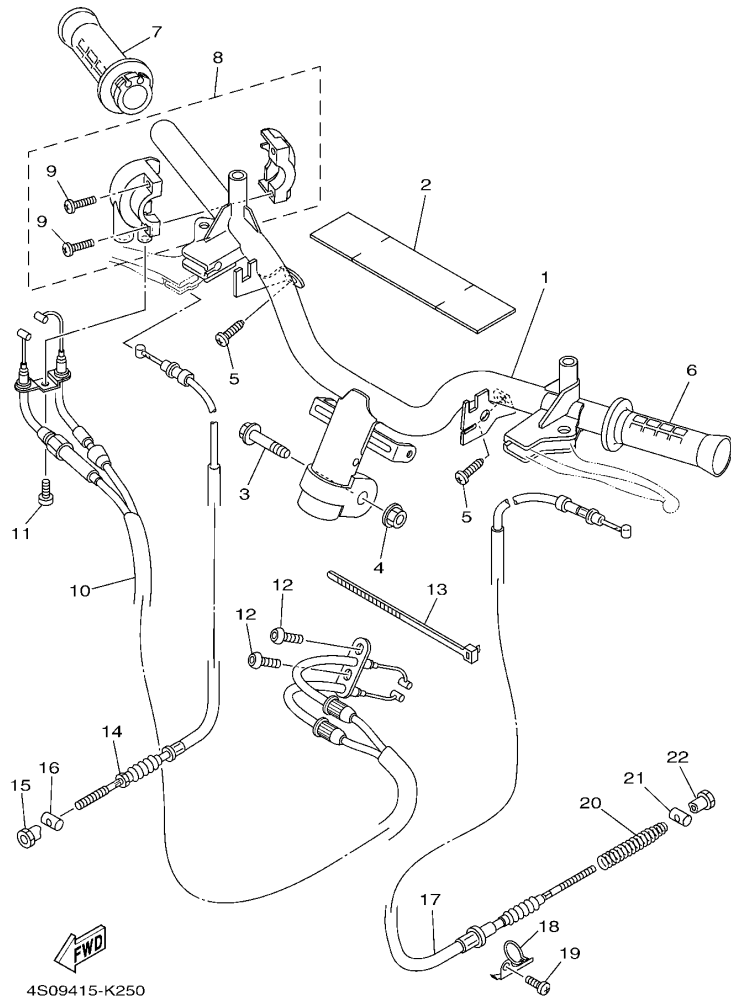

4S09415-K250

参照 号码	零件号码 PART NO.	零件名称 DESCRIPTION	4S09	4S0A		备注 REMARKS
1	4S0-F6110-00	手柄组件 HANDLE COMP.	1			
2	5WG-F6113-00	减震器 DAMPER	1			
3	90105-10839	凸缘螺栓 BOLT, FLANGE	1			
4	95602-10200	自锁螺母 NUT, U FLANGE	1			
5	97702-50016	自攻螺钉 SCREW, TAPPING	2			
6	4KL-F6241-20	握把(左边) GRIP	1			
7	4S0-F6240-00	握把(右边) GRIP ASSY	1			
8	4P7-F6270-01	钢索连接器盖组合 CAP GRIP ASSY	1			
9	98502-05020	十字螺钉 SCREW, PAN HEAD	2			
10	4S0-F6301-00	油门钢索组合 THROTTLE CABLE ASSY	1			
11	98502-05010	十字螺钉 SCREW, PAN HEAD	1			
12	92012-05010	螺钉 BOLT, BUTTON HEAD	2			
13	90464-20809	线夹 CLAMP	1			
14	5WG-F6341-01	制动拉索 1 WIRE, BRAKE 1	1			
15	90179-06843	螺母 NUT	1			
16	90249-12806	销 PIN	1			
17	4S0-F6351-01	制动器钢索 CABLE, BRAKE	1			
18	4KL-F637G-01	钢索支架 HOLDER, WIRE	1			
19	98502-06012	十字螺钉 SCREW, PAN HEAD	1			
20	90501-16831	压簧 SPRING, COMPRESSION	1			
21	90249-12806	销 PIN	1			
22	90179-06843	螺母 NUT	1			

FIG. 26 操纵手柄 钢索(碟刹)

STEERING CABLE FOR DISK BRAKE

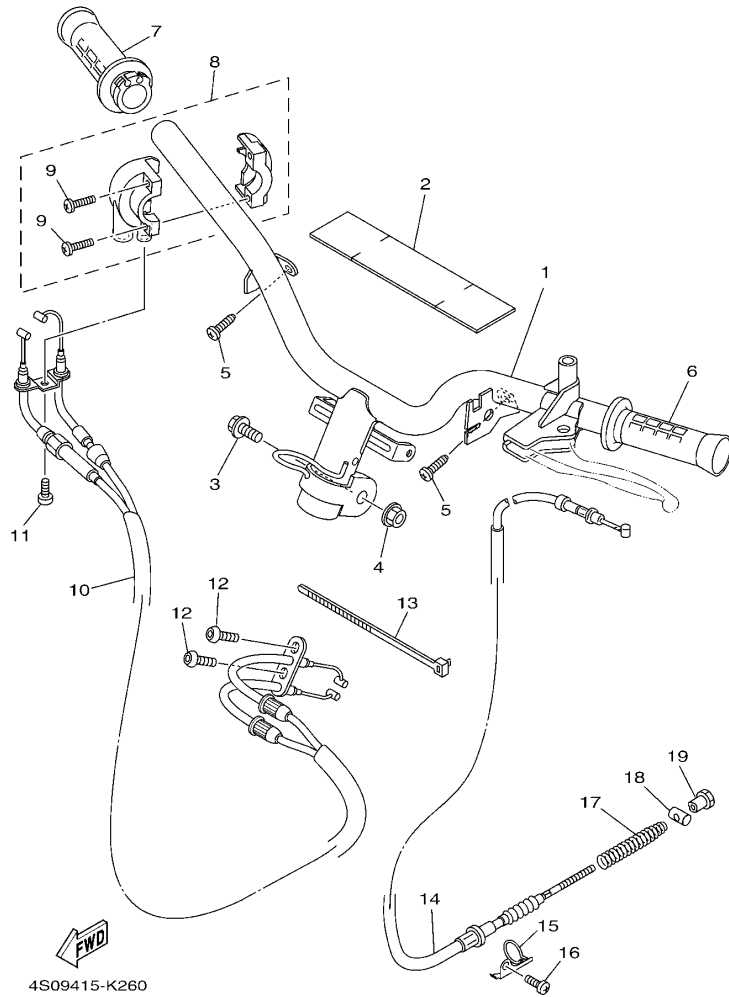

4S09415-K260

参照 号码	零件号码 PART NO.	零件名称 DESCRIPTION	4S09	4S0A	备注 REMARKS
1	4S0-F6110-11	手柄组件 HANDLE COMP.		1	
2	5WG-F6113-00	减震器 DAMPER		1	
3	90105-10839	凸缘螺栓 BOLT, FLANGE		1	
4	95602-10200	自锁螺母 NUT, U FLANGE		1	
5	97702-50016	自攻螺钉 SCREW, TAPPING		2	
6	4KL-F6241-20	握把(左边) GRIP		1	
7	4S0-F6240-00	握把(右边) GRIP ASSY		1	
8	4P7-F6270-01	钢索连接器盖组合 CAP GRIP ASSY		1	
9	98502-05020	十字螺钉 SCREW, PAN HEAD		2	
10	4S0-F6301-00	油门钢索组合 THROTTLE CABLE ASSY		1	
11	98502-05010	十字螺钉 SCREW, PAN HEAD		1	
12	92012-05010	螺钉 BOLT, BUTTON HEAD		2	
13	90464-20809	线夹 CLAMP		1	
14	4S0-F6351-01	制动器钢索 CABLE, BRAKE		1	
15	4KL-F637G-01	钢索支架 HOLDER, WIRE		1	
16	98502-06012	十字螺钉 SCREW, PAN HEAD		1	
17	90501-16831	压簧 SPRING, COMPRESSION		1	
18	90249-12806	销 PIN		1	
19	90179-06843	螺母 NUT		1	

FIG. 27 前主缸

FRONT MASTER CYLINDER

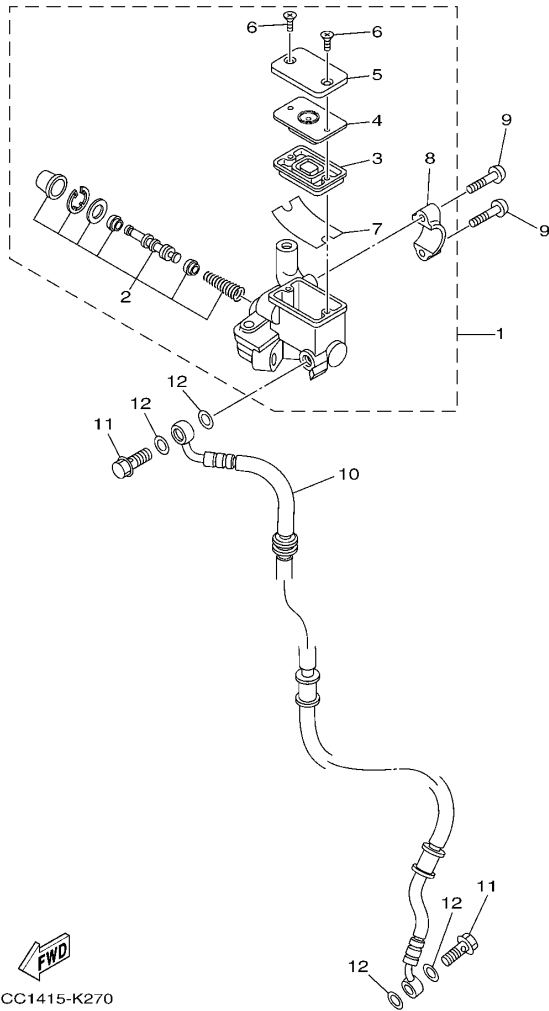

1CC1415-K270

参照 号码	零件号码 PART NO.	零件名称 DESCRIPTION	4S09	4S0A	备注 REMARKS
1	4KL-F5870-21	主缸副组合 MASTER CYLINDER SUB ASSY		1	
2	3D9-W0041-02	.前主缸套件 .CYLINDER KIT, MASTER		1	
3	4KL-F5854-00	.油箱隔膜 .DIAPHRAGM, RESERVOIR		1	
4	4KL-F585B-00	.隔板 .PLATE, DIAPHRAGM		1	
5	4KL-F5852-00	.储油箱盖 .CAP, RESERVOIR		1	
6	4KL-F589H-01	.螺钉 .SCREW		2	
7	4KL-F5896-00	.储油箱面板 .PLATE, RESERVOIR		1	
8	4KL-F5867-00	.主缸托架 .BRACKET, MASTER CYLINDER		1	
9	92012-06025	螺钉 BOLT, BUTTON HEAD		2	
10	4P7-F5872-01	制动软管 1 HOSE, BRAKE 1		1	
11	90401-10823	螺栓 BOLT, UNION		2	
12	90201-108J9	平垫圈 WASHER, PLATE		4	

STAND & FOOTREST

FIG. 28 搁脚·支架

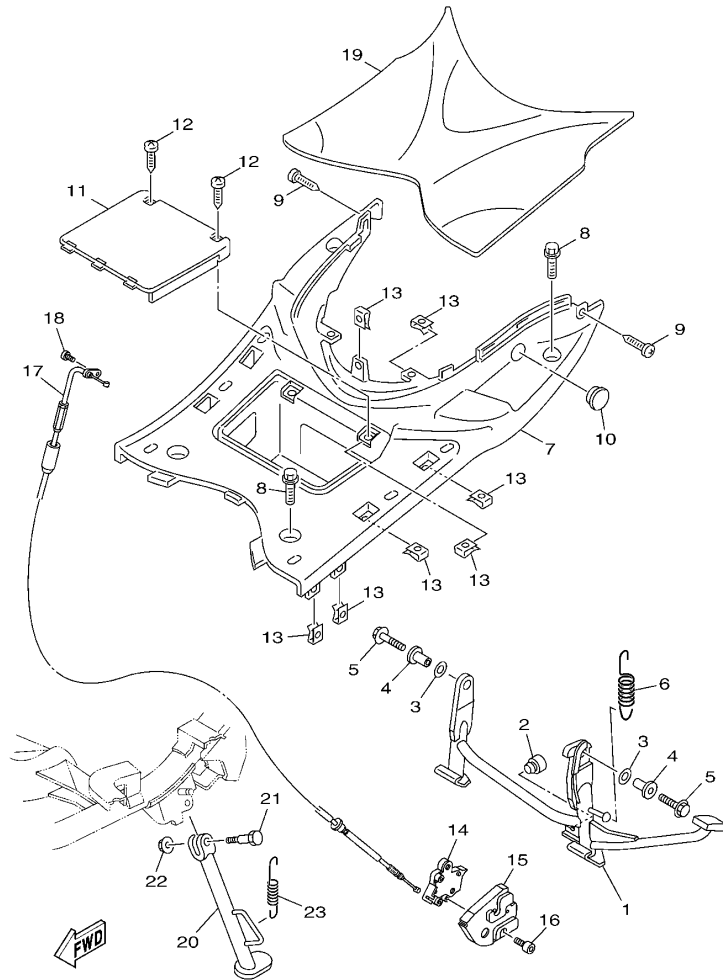

4S01415-E280

参照 号码	零件号码 PART NO.	零件名称 DESCRIPTION	4S09	4S0A	备注 REMARKS
1	4S0-F7111-00	主支承 STAND, MAIN	1	1	
2	4KL-F7314-00	限位板 STOPPER	1	1	
3	90202-15804	平垫圈 WASHER, PLATE	2	2	
4	5WG-F7113-01	主支承安装 COLLAR, MAIN STAND	2	2	
5	95812-10035	凸缘螺栓 BOLT, FLANGE	4	4	
6	90506-35820	拉簧 SPRING, TENSION	1	1	
7	5WG-F7481-00	搁脚踏板 BOARD, FOOTREST	1	1	
8	90119-06157	带垫螺栓 BOLT, WITH WASHER	4	4	
9	97702-50012	自攻螺钉 SCREW, TAPPING	2	2	
10	5WG-F6199-00	绝缘插头 PLUG, BLIND	1	1	
11	5WG-H2129-00	蓄电池盖 COVER, BATTERY	1	1	
12	97702-50012	自攻螺钉 SCREW, TAPPING	2	2	
13	90183-05818	弹性螺母 NUT, SPRING	13	13	
14	4S0-F7180-01	锁紧装置组合 LOCK ASSY	1	1	
15	4S0-F7151-00	主支承托架 BRACKET, MAIN STAND	1	1	
16	90149-06827	螺钉 SCREW	2	2	
17	16D-F473J-01	电线 WIRE	1	1	
18	98502-05012	十字螺钉 SCREW, PAN HEAD	1	1	
19	5WG-F7483-00	衬垫 1 MAT 1	1	1	
20	4S0-F7311-00	侧支承 STAND, SIDE	1	1	
21	90109-08836	螺栓 BOLT	1	1	
22	95602-08200	自锁螺母 NUT, SELF-LOCKING	1	1	
23	90506-20816	拉簧 SPRING, TENSION	1	1	

FIG. 29 护腿

LEG SHIELD

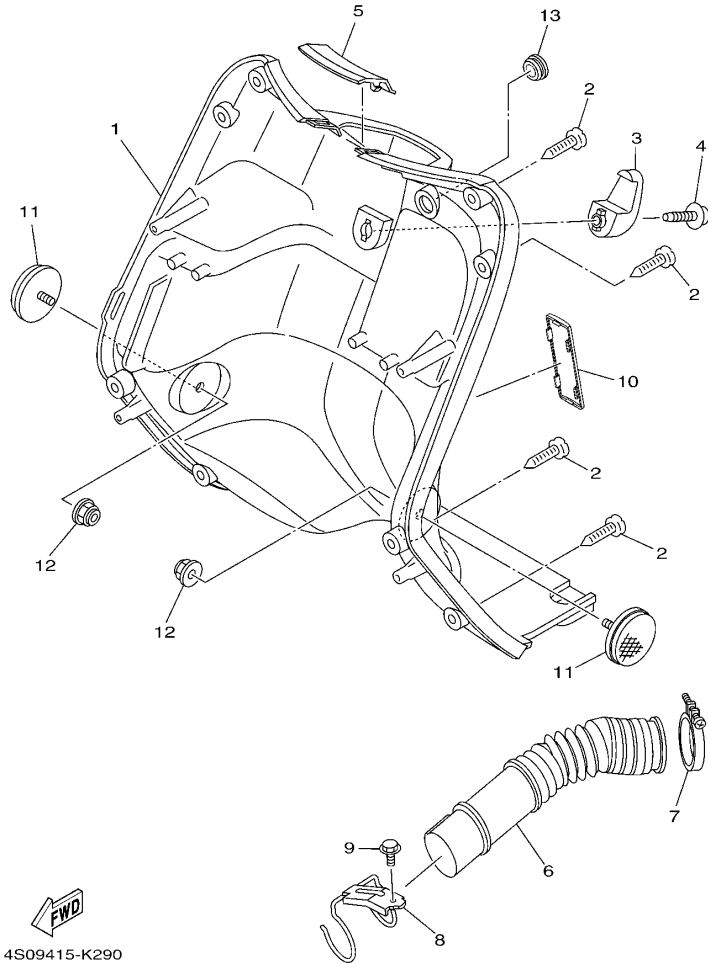

4S09415-K290

参照 号码	零件号码 PART NO.	零件名称 DESCRIPTION	4S09	4S0A			备注 REMARKS
1	4S0-F8300-01	护腿装置组合 LEG SHIELD ASSY	1	1			
2	97702-50016	自攻螺钉 SCREW, TAPPING	8	8			
3	5WG-F8257-01	钩 1 HOOK 1	1	1			
4	90159-06856	带垫螺钉 SCREW, WITH WASHER	1	1			
5	5WG-F8365-00	盖 COVER	1	1			
6	5WG-F1557-00	空气管道 DUCT, AIR	1	1			
7	5WG-F1823-01	软管夹 CLAMP, HOSE	1	1			
8	5WG-F1161-01	钢索支架 HOLDER, CABLE	1	1			
9	95802-06012	凸缘螺栓 BOLT, FLANGE	1	1			
10	4KL-F8349-10	盖 CAP	1	1			
11	4KL-H5131-12	后反射镜 1 REFLECTOR, REAR 1	2	2			
12	95602-05200	自锁螺母 NUT, SELF-LOCKING	2	2			
13	5MH-F6199-00	绝缘插头 PLUG, BLIND	1	1			

FIG. 30 导流罩 1

COWLING 1

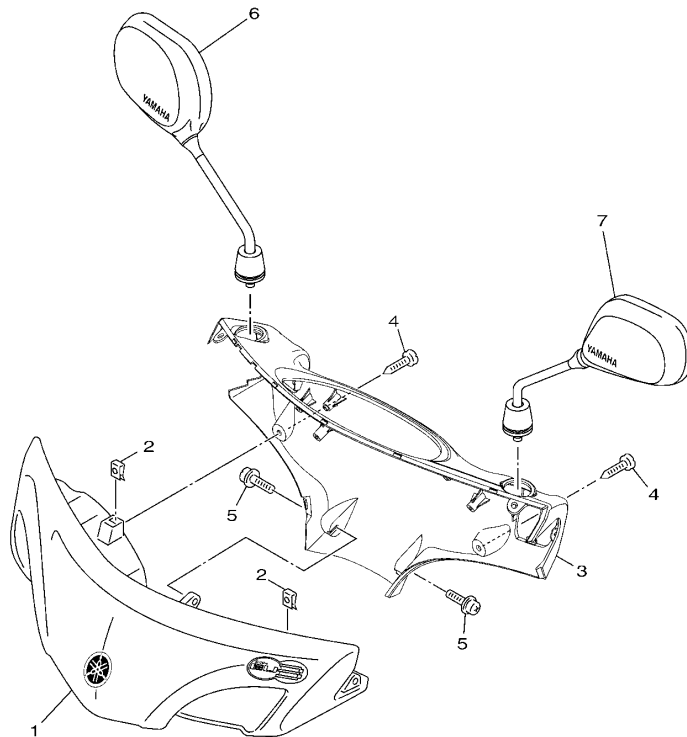



4S09415-K300

参照 号码	零件号码 PART NO.	零件名称 DESCRIPTION	4S09	4S0A			备注 REMARKS
1	4S0-X2610-11-PB	手把杆上侧盖 1 COVER, HANDLEBAR UPPER 1	1				UR 深鸡尾红色 2 车用 UR FOR DRC2
	4S0-X2610-11-PA	手把杆上侧盖 1 COVER, HANDLEBAR UPPER 1	1				UR 特暗蓝 4 车用 UR FOR VDBC4
	4S0-X2610-11-P2	手把杆上侧盖 1 COVER, HANDLEBAR UPPER 1	1				UR 金属黑色车用 UR FOR SMX
	4S0-X2610-11-P9	手把杆上侧盖 1 COVER, HANDLEBAR UPPER 1	1				UR 浅蓝鸡尾白色 1 车用 UR FOR BWC1
	4S0-X2610-02-P1	手把杆上侧盖 1 COVER, HANDLEBAR UPPER 1		1			UR 银 3 车用 UR FOR S3
	4S0-X2610-02-UG	手把杆上侧盖 1 COVER, HANDLEBAR UPPER 1		1			UR 棕色车用 UR FOR IPB
	4S0-X2610-02-P2	手把杆上侧盖 1 COVER, HANDLEBAR UPPER 1		1			UR 金属黑色车用 UR FOR SMX
	4S0-X2610-02-P9	手把杆上侧盖 1 COVER, HANDLEBAR UPPER 1		1			UR 浅蓝鸡尾白色 1 车用 UR FOR BWC1
2	90183-05818	弹性螺母 NUT, SPRING	2	2			
3	4P7-F6145-00	手把杆上侧盖 2 COVER,HAND,UPPER 2	1	1			
4	97702-50016	自攻螺钉 SCREW, TAPPING	2	2			
5	97602-05216	带垫圈大柱头螺钉 SCREW, PAN HEAD WITH WASHER	2	2			
6	4S0-F6290-02	后视镜组合 (右边) REAR VIEW MIRROR ASSY (RIGHT)	1	1			
7	4S0-F6280-02	后视镜组合 (左边) REAR VIEW MIRROR ASSY (LEFT)	1	1			

FIG. 31 发电机

GENERATOR

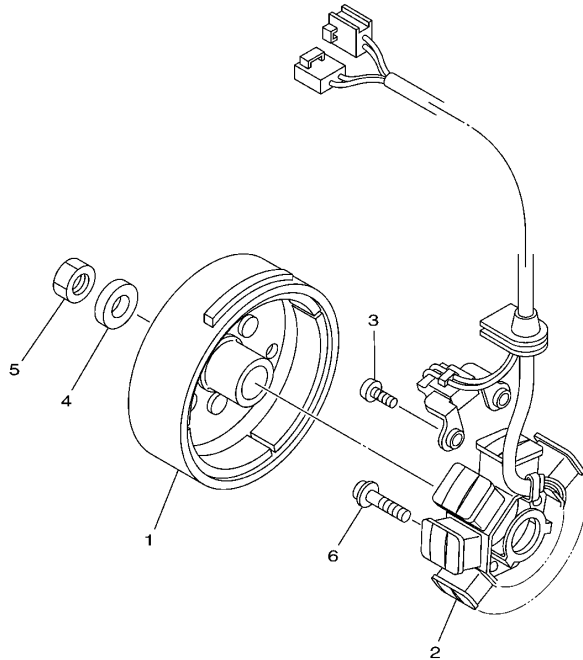
参照 号码	零件号码 PART NO.	零件名称 DESCRIPTION	4S09	4S0A			备注 REMARKS
1	5WY-H1450-01	转子组合 ROTOR ASSY	1	1			
2	5WY-H1410-11	定子组合 STATOR ASSY	1	1			
3	98502-06016	十字螺钉 SCREW, PAN HEAD	2	2			
4	90387-12853	轴套 COLLAR	1	1			
5	90170-12181	螺母 NUT	1	1			
6	97602-06225	带垫圈大柱头螺钉 SCREW, PAN HEAD WITH WASHER	3	3			
<hr/>							
<hr/>							
<hr/>							
<hr/>							
<hr/>							
<hr/>							
<hr/>							
<hr/>							



1CC1415-K310

FIG. 32 起动机

STARTING MOTOR

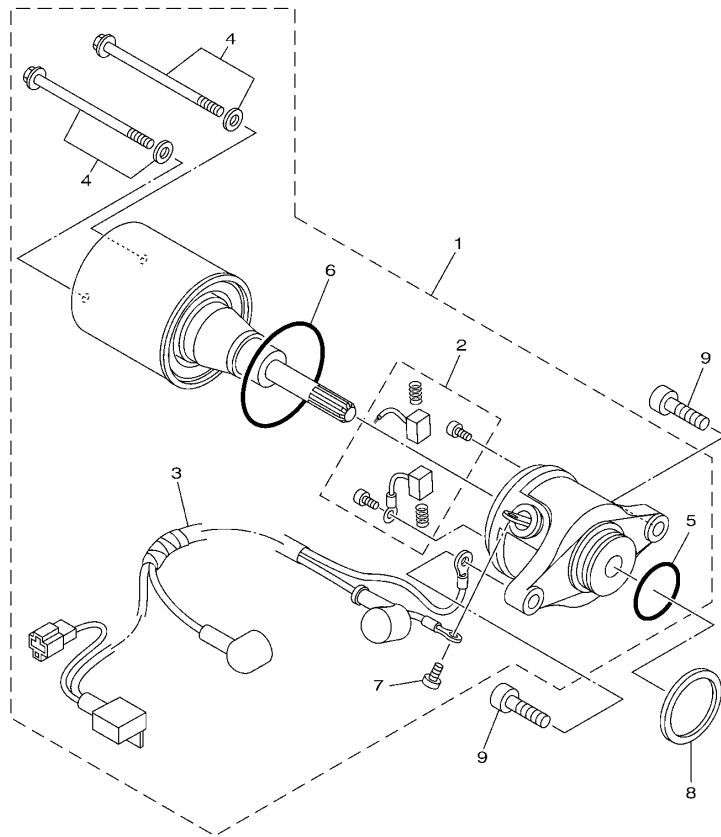

4S09415-K320

参照 号码	零件号码 PART NO.	零件名称 DESCRIPTION	4S09	4S0A			备注 REMARKS
1	4S0-H1800-10	起动机组合 STARTING MOTOR ASSY	1	1			
2	4RT-H1801-00	. 碳刷组件 . BRUSH SET	1	1			
3	4S0-H183G-00	. 导线组件 . CORD COMP.	1	1			
4	5WV-H1828-01	. 组合螺钉 . SCREW 2	2	2			
5	93210-23614	. O型环 . O-RING	1	1			
6	93210-44678	. O型环 . O-RING	1	1			
7	98902-05008	. 十字槽盘头螺钉 . SCREW, BIND	1	1			
8	90202-26801	. 平垫圈 . WASHER, PLATE	1	1			
9	91312-06020	. 螺栓 . BOLT	2	2			

FIG. 33 转向灯

FLASHER LIGHT

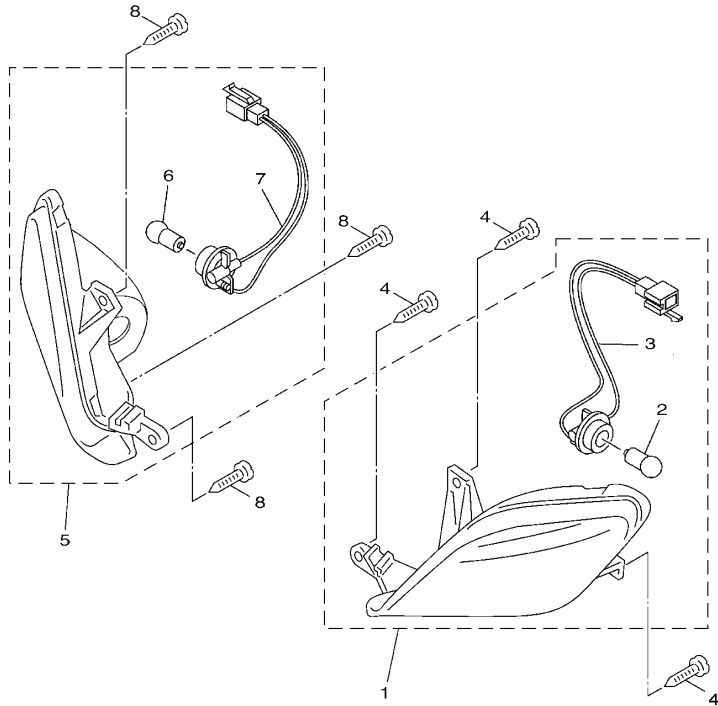

参照 号码	零件号码 PART NO.	零件名称 DESCRIPTION	4S09	4S0A			备注 REMARKS
1	4P7-H3310-12	前转向灯组合 1 FRONT FLASHER LIGHT ASSY 1	1	1			
2	4P7-H3311-10	. 转向灯灯泡 .BULB, FLASHER (12V-10W)	1	1			
3	4P7-H331E-00	. 缆索组合 .CORD ASSY	1	1			
4	97702-50016	自攻螺钉 SCREW, TAPPING	3	3			
5	4P7-H3320-12	前转向灯组合 2 FRONT FLASHER LIGHT ASSY 2	1	1			
6	4P7-H3311-10	. 转向灯灯泡 .BULB, FLASHER (12V-10W)	1	1			
7	4P7-H332E-00	. 缆索组合 .CORD ASSY	1	1			
8	97702-50016	自攻螺钉 SCREW, TAPPING	3	3			

FIG. 34 仪表

METER

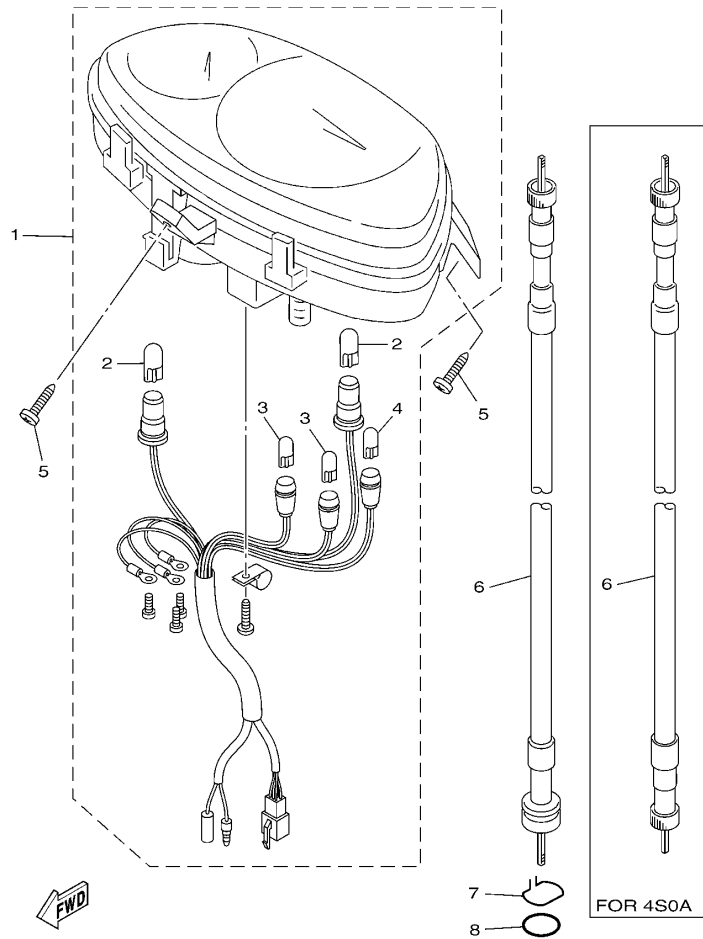

4S09415-K340

参照 号码	零件号 PART NO.	零件名称 DESCRIPTION	4S09	4S0A	备注 REMARKS
1	4S0-H3510-01	测速计组合 SPEEDOMETER ASSY	1	1	
2	5WG-H3517-V0	.灯泡 (T10 12V-3.4W) .BULB (T10 12V-3.4W)	2	2	
3	5WG-H3517-00	.灯泡 (T6.5 12V-1.7W) .BULB (T6.5 12V-1.7W)	2	2	
4	5WG-H3517-10	.灯泡 (T6.5 12V-3.4W) .BULB (T6.5 12V-3.4W)	1	1	
5	97702-50016	自攻螺钉 SCREW, TAPPING	3	3	
6	5WG-H3550-01	速度计软轴组合 SPEEDOMETER CABLE ASSY	1		
	5WG-H3550-11	速度计软轴组合 SPEEDOMETER CABLE ASSY		1	
7	4KL-F5137-21	制动环 RING, STOP	1		
8	93210-14104	O型环 O-RING	1		

FIG. 35 前大灯

HEADLIGHT

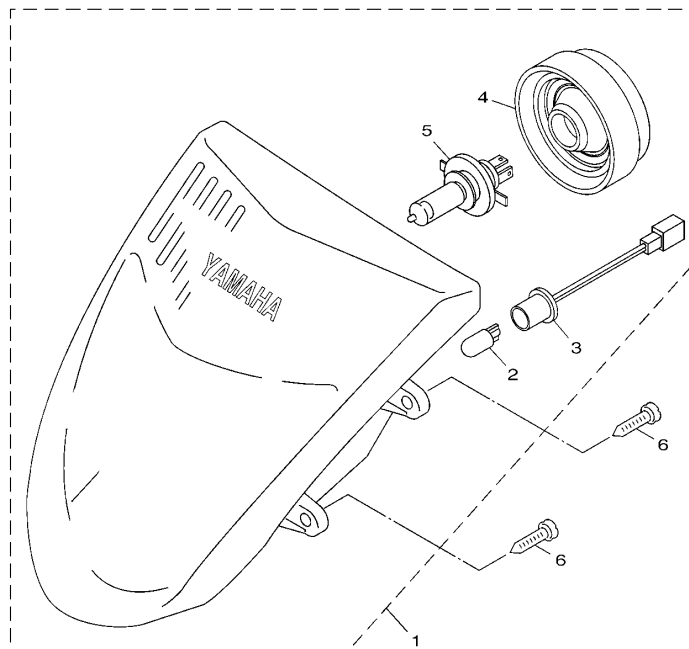

参照 号码	零件号码 PART NO.	零件名称 DESCRIPTION	4S09	4S0A			备注 REMARKS
1	4P7-H4310-02	大灯组件 HEADLIGHT UNIT ASSY	1	1			
2	4P7-H4347-00	. 灯泡 . BULB (12V-3W)	1	1			
3	4P7-H4312-00	. 导线组合 . CORD ASSY	1	1			
4	4P7-H4396-00	. 盖 . COVER	1	1			
5	4P7-H4314-00	. 前照灯灯泡 . BULB, HEADLIGHT (12V-35/35W)	1	1			
6	97702-50016	自攻螺钉 SCREW, TAPPING	4	4			

FIG. 36 尾灯

TAILLIGHT

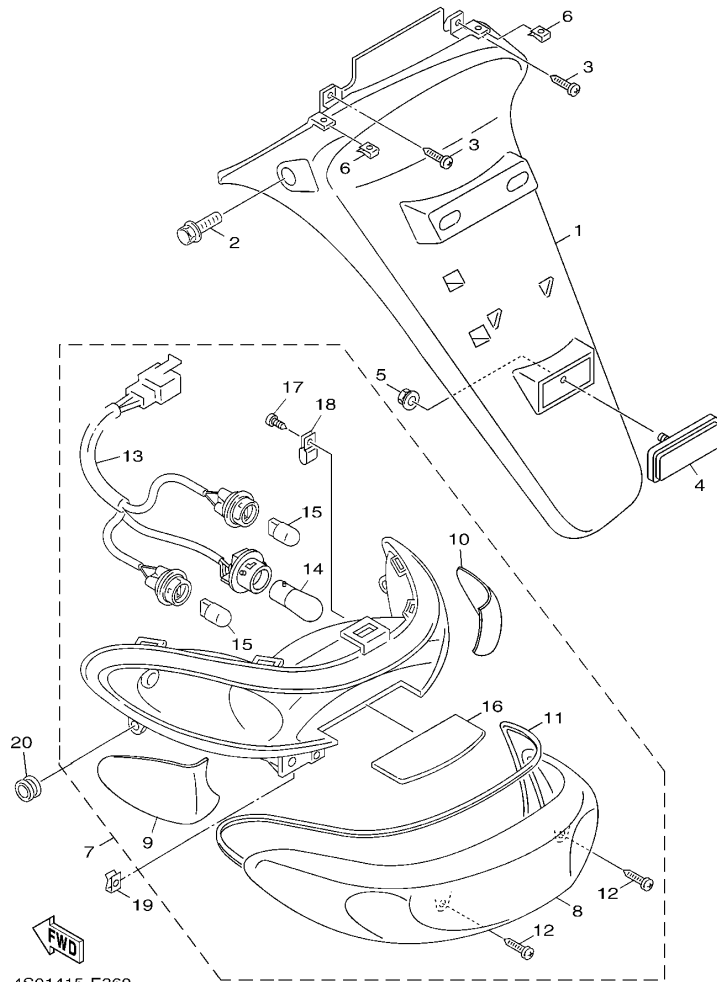

4S01415-E360

参照 号码	零件号码 PART NO.	零件名称 DESCRIPTION	4S09	4S0A	备注 REMARKS
1	5WG-F1685-00	车牌托架 BRACKET, LICENSE	1	1	
2	90109-06822	螺栓 BOLT	2	2	
3	97702-50012	自攻螺钉 SCREW, TAPPING	2	2	
4	4P7-H5130-01	后反射镜组合 REAR REFLECTOR ASSY	1	1	
5	95602-05200	自锁螺母 NUT, SELF-LOCKING	1	1	
6	90183-05818	弹性螺母 NUT, SPRING	2	2	
7	4P7-H4700-03	尾灯组合 TAILLIGHT ASSY	1	1	
8	4P7-H4540-01	镜面组合 .LENS ASSY	1	1	
9	4P7-H333L-00	闪烁器内镜 .LENS, INNER 1	1	1	
10	4P7-H333M-00	闪烁灯泡罩 .LENS, INNER 2	1	1	
11	4P7-H4723-00	尾灯镜面衬垫 .GASKET, TAIL LENS	1	1	
12	4P7-H4724-00	镜面安装螺钉 .SCREW, LENS FITTING	2	2	
13	4P7-H4735-00	缆索组合 .SOCKET CORD ASSY	1	1	
14	4P7-H4714-00	灯泡 .BULB, TAILLIGHT (12V-21/5W)	1	1	
15	4P7-H3331-00	闪烁灯泡 .BULB, FLASHER (12V-16W)	2	2	
16	4P7-H4743-00	牌照灯镜头 .LENS, LICENCE LIGHT	1	1	
17	4P7-H4726-00	螺钉 .SCREW	1	1	
18	4P7-H4746-00	座位基座面板 .PLATE, SEAT BASE	1	1	
19	90183-05818	弹性螺母 NUT, SPRING	2	2	
20	90480-14023	橡胶垫 GROMMET	2	2	

FIG. 37 手柄开关(鼓刹)

SWITCH & LEVER FOR DRUM BRAKE

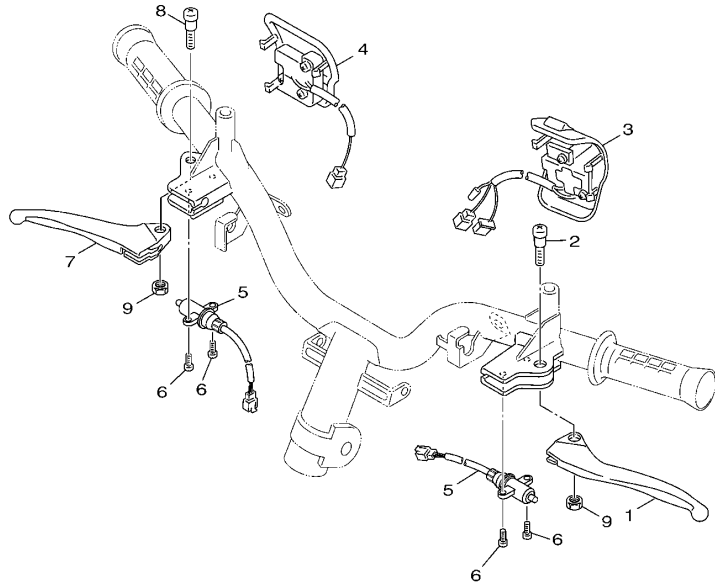

参照 号码	零件号码 PART NO.	零件名称 DESCRIPTION	4S09	4S0A			备注 REMARKS
1	5WY-H3912-11	手柄 1 LEVER 1	1				
2	90157-05812	大柱头螺钉 SCREW, PAN HEAD	1				
3	4S0-H3963-01	手把开关 3(右边) SWITCH, HANDLE 3	1				
4	4S0-H3975-01	手把开关 2 SWITCH, HANDLE 2	1				
5	1CC-H3980-00	前制动开关组合 FRONT STOP SWITCH ASSY	2				
6	98502-03006	十字螺钉 SCREW, PAN HEAD	4				
7	5WY-H3922-01	手柄 2 LEVER 2	1				
8	90157-05812	大柱头螺钉 SCREW, PAN HEAD	1				
9	95602-05100	锁紧螺母 NUT, U	2				

FIG. 38 手柄开关(碟刹)

SWITCH & LEVER FOR DISK BRAKE

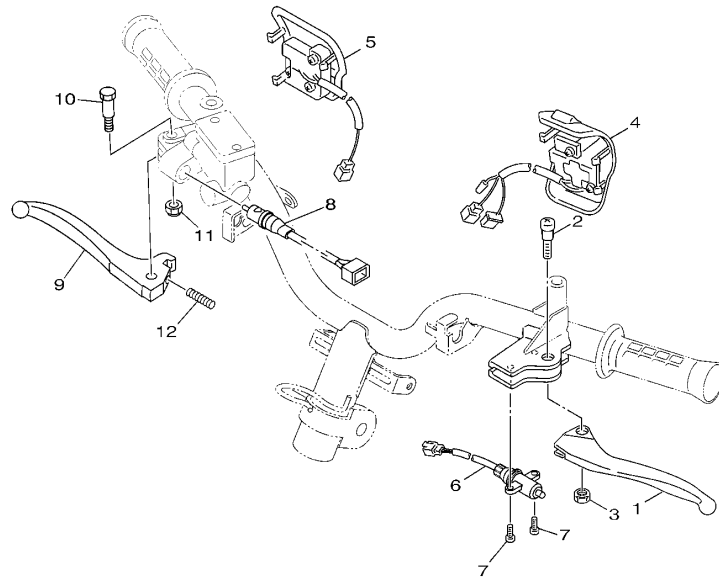

参照 号码	零件号码 PART NO.	零件名称 DESCRIPTION	4S09	4S0A			备注 REMARKS
1	5WY-H3912-11	手柄 1 LEVER 1		1			
2	90157-05812	大柱头螺钉 SCREW, PAN HEAD		1			
3	95602-05100	锁紧螺母 NUT, U		1			
4	4S0-H3963-01	手把开关 3(右边) SWITCH, HANDLE 3		1			
5	4S0-H3975-01	手把开关 2 SWITCH, HANDLE 2		1			
6	1CC-H3980-00	前制动开关组合 FRONT STOP SWITCH ASSY		1			
7	98502-03006	十字螺钉 SCREW, PAN HEAD		2			
8	5MH-H3980-11	前制动开关组合 FRONT STOP SWITCH ASSY		1			
9	4S0-H3922-00	手柄 2 LEVER 2		1			
10	90109-06255	螺栓 BOLT		1			
11	95602-06100	锁紧螺母 NUT, U		1			
12	90501-10312	压簧 SPRING, COMPRESSION		1			

4S05415-H380

FIG. 39 电气系统 1

ELECTRICAL 1

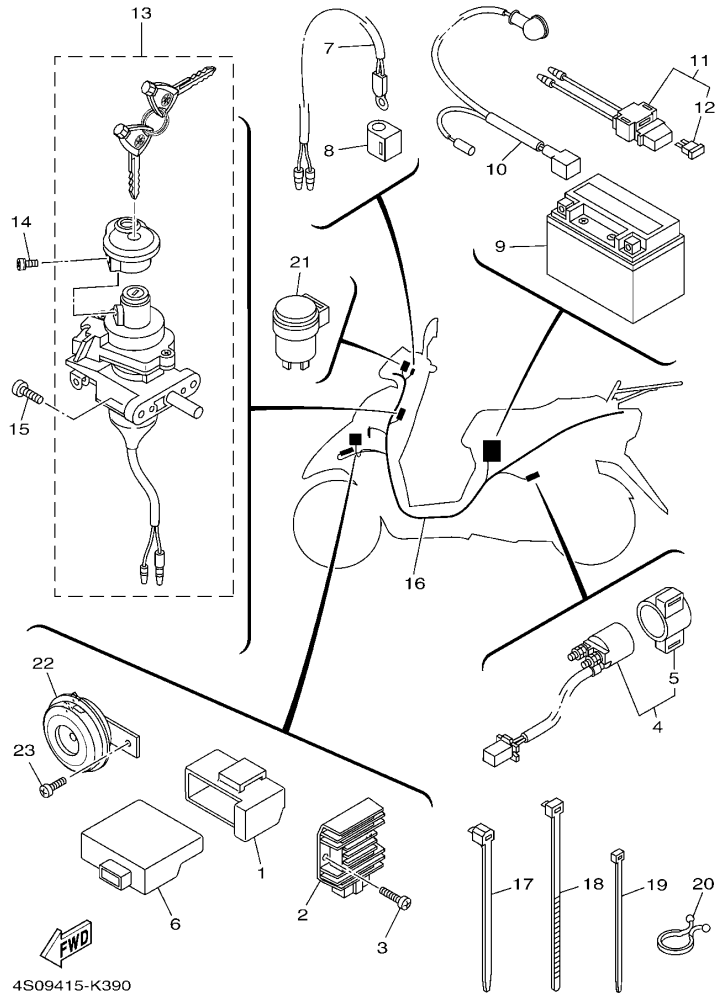

4S09415-K390

参照 号码	零件号码 PART NO.	零件名称 DESCRIPTION	4S09	4S0A	备注 REMARKS
1	4S0-H5546-00	箍带 BAND	1	1	
2	5WY-H1960-10	整流调节器 RECTIFIER & REGULATOR ASSY	1	1	
3	98502-06012	十字螺钉 SCREW, PAN HEAD	2	2	
4	5WG-H1940-30	起动机继电器组合 STARTER RELAY ASSY	1	1	
5	5WG-H1952-10	继电器支架 .HOLDER, RELAY	1	1	
6	5WY-H5540-21	CDI 总成 C.D.I. UNIT ASSY	1	1	
7	1CC-H5700-00	温度传感器 THERMISTOR ASSY	1	1	
8	4S0-H3836-00	卡箍 BAND	1	1	
9	4KL-H2100-00	蓄电池组合 BATTERY (GTX7A-BS)	1	1	
10	5WG-H2115-00	正极导线 WIRE, PLUS LEAD	1	1	
11	4KL-H2170-10	保险丝盒组合 FUSE BOX ASSY	1	1	
12	4KL-H2151-10	保险丝 .FUSE (15A-BL)	1	1	
13	1CC-X8250-01	锁组合 LOCK ASSY.	1	1	
14	97602-05212	带垫圈大柱头螺钉 SCREW, PAN HEAD WITH WASHER	1	1	
15	98502-06012	十字螺钉 SCREW, PAN HEAD	2	2	
16	4S0-H2590-30	电缆总成 WIRE HARNESS ASSY	1	1	
17	90464-12812	线夹 CLAMP	5	5	
18	90464-20809	线夹 CLAMP	1	1	
19	90465-13152	夹箍 CLAMP	2	2	
20	90464-23811	线夹 CLAMP	1	1	
21	5WG-H3350-00	闪烁继电器组合 FLASHER RELAY ASSY	1	1	
22	5WG-H3371-10	电喇叭 HORN	1	1	
23	98502-06010	十字螺钉 SCREW, PAN HEAD	1	1	

FIG. 40 电气系统 2

ELECTRICAL 2

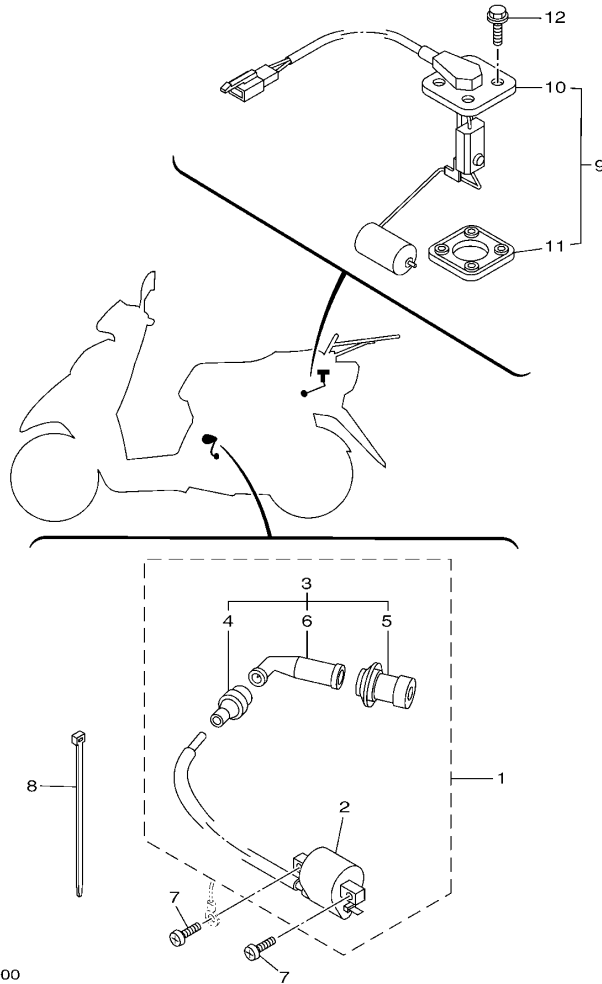

参照 号码	零件号码 PART NO.	零件名称 DESCRIPTION	4S09	4S0A	备注 REMARKS
1	4S0-X8231-30	点火线圈组合 IGN. COIL ASSY.	1	1	
2	4S0-H2310-10	点火线圈组合 IGNITION COIL ASSY	1	1	
3	4S0-H2370-00	火花塞帽组合 PLUG CAP ASSY	1	1	
4	4FP-H2371-00	塞帽 CAP, PLUG	1	1	
5	4KL-H2372-00	塞帽密封 SEAL, PLUG CAP	1	1	
6	4S0-H2373-00	高压缆索密封 SEAL, HIGH TENSION CORD	1	1	
7	98502-06018	十字螺钉 SCREW, PAN HEAD	2	2	
8	90465-13152	夹箍 CLAMP	1	1	
9	5WG-X8575-10	传感装置组合 SENDER UNIT ASSY	1	1	
10	5WG-H5752-01	燃油表传感装置组合 SENDER UNIT ASSY, FUEL METER	1	1	
11	4KL-H5753-00	传感器垫圈 GASKET, SENDER UNIT	1	1	
12	90119-05802	带垫螺栓 BOLT, WITH WASHER	4	4	

零件号码索引
NUMERICAL INDEX

零件号码 PART NO.	参照 号码	零件号码 PART NO.	参照 号码	零件号码 PART NO.	参照 号码	零件号码 PART NO.	参照 号码	零件号码 PART NO.	参照 号码	零件号码 PART NO.	参照 号码
1CC-E111F-00	1 - 18	1CC-E3575-00	6 - 4	4S0-E4987-00	1 - 39	1CC-E7660-00	11 - 22	5WG-F1731-00-P9	15 - 11	5AP-F3153-00	17 - 19
1CC-E1145-00	3 - 2	1CC-E3585-00	6 - 1	1CC-E5111-00	9 - 1	1CC-E7664-00	11 - 26	5WG-F1731-00-PB	15 - 11		18 - 5
1CC-E1155-00	1 - 25	1CC-E3595-00	6 - 21	1CC-E5121-00	9 - 2	1CC-E7670-00	11 - 23	5WG-F1731-00-PC	15 - 11		18 - 19
1CC-E1160-01	1 - 21	5WB-E4105-10	7 - 17	1CC-E5138-00	9 - 3	1CC-E7684-00	11 - 28	5WG-F1731-00-UG	15 - 11	5WG-F3170-00	17 - 8
1CC-E1165-00	1 - 23	5WB-E4115-00	7 - 10	1CC-E5191-00	9 - 26	4S0-F1110-01	13 - 1	5WG-F1741-00-P1	15 - 13		17 - 22
1CC-E1181-00	1 - 33	5WB-E4283-10	7 - 4	5WG-E5317-01	13 - 3	5WG-F1161-01	29 - 8	5WG-F1741-00-P2	15 - 13	4P7-F3170-10	18 - 8
1CC-E1185-00	1 - 22	5WB-E4286-10	7 - 11	4KL-E5351-10	5 - 9	5WG-F116F-11	13 - 14	5WG-F1741-00-P9	15 - 13		18 - 22
4KL-E1186-00	1 - 28	1CC-E4301-00	7 - 1	4KL-E5363-00	9 - 16	5WG-F118W-00	13 - 7	5WG-F1741-00-PB	15 - 13	4GU-F3173-01	17 - 9
1CC-E1310-02	1 - 37	5WB-E4340-00	7 - 13	1CC-E5363-10	9 - 37	4S0-F1274-00	13 - 16	5WG-F1741-00-PC	15 - 13		17 - 23
1CC-E1351-00	1 - 38	5WB-E4342-16	7 - 6	1CC-E5371-00	9 - 5	4S0-F1410-20	13 - 10	5WG-F1741-00-UG	15 - 13		18 - 9
1CC-E1400-00	2 - 1	5WB-E4343-52	7 - 7	1CC-E5373-00	9 - 6	5WG-F1481-01	13 - 8	5WG-F1746-00	15 - 6		18 - 23
1CC-E1603-00	2 - 9	5WB-E4346-00	7 - 20	4S0-E5393-00	9 - 9	5WG-F1482-01	13 - 11	4S0-F1753-00	19 - 17	4KL-F3191-10	17 - 14
1CC-E1631-00	2 - 6	5WB-E4370-10	7 - 19	1CC-E5407-00	9 - 41	5WG-F1511-01-P1	14 - 1	5WY-F1753-00	19 - 13		17 - 28
1CC-E1633-00	2 - 7	5WB-E4384-10	7 - 14	1CC-E5411-00	9 - 22	5WG-F1511-01-P2	14 - 1	5WG-F1773-00	15 - 16		18 - 14
1CC-E2111-00	1 - 7	5WB-E4385-10	7 - 18	1CC-E5417-00	9 - 29	5WG-F1511-01-P9	14 - 1	5WG-F1823-01	29 - 7		18 - 28
1CC-E2113-00	1 - 11	5LB-E4386-00	7 - 9	1CC-E5421-00	9 - 18	5WG-F1511-01-UG	14 - 1	455-F2210-00	16 - 1	4KL-F3192-11	17 - 15
1CC-E2116-00	1 - 10	5WB-E4390-00	7 - 8	1CC-E5451-00	9 - 23	5WG-F1519-01-C1	14 - 13	4KL-F2216-00	9 - 4		17 - 29
1CC-E2117-00	1 - 13	4S0-E4409-00	6 - 15	1CC-E5455-00	9 - 27	5WG-F1519-01-P2	14 - 13	4S0-F3100-02	17 - 1		18 - 15
1CC-E2118-00	1 - 12	4S0-E4410-03	6 - 5	1CC-E5461-00	9 - 19	5WG-F1519-01-P8	14 - 13	4S0-F3100-12	18 - 1		18 - 29
1CC-E2119-00	1 - 9	4S0-E4411-02	6 - 7	1CC-E5471-00	9 - 39	5WG-F1519-01-P9	14 - 13	4S0-F3102-02	17 - 2	1CC-F3317-10	17 - 44
1CC-E2121-00	1 - 8	4S0-E4412-01	6 - 6	1CC-E5472-00	9 - 40	5WG-F1519-01-PA	14 - 13	4S0-F3102-12	18 - 2		18 - 44
1CC-E2151-00	1 - 14	4S0-E4437-00	6 - 11	1CC-E5481-00	9 - 44	5WG-F1521-00	13 - 18	4S0-F3103-02	17 - 16	5WG-F3340-00	17 - 30
1CC-E2156-00	1 - 17	5WY-E443E-01	6 - 14	5WG-E5521-00	10 - 3	5WG-F1523-00	14 - 4	4S0-F3103-12	18 - 16	4P7-F3340-10	18 - 30
5MH-E2157-01	3 - 12	4S0-E443G-00	6 - 16	1CC-E5524-00	10 - 7	5WG-F1552-04	14 - 6	5WG-F3110-00	17 - 6	4RT-F3346-01	17 - 33
1CC-E2159-00	1 - 15	5WY-E4445-00	8 - 5	5MH-E5532-00	10 - 5	5WG-F1553-00	14 - 11		17 - 20		18 - 33
1CC-E2170-00	1 - 20	4S0-E4451-01	6 - 8	1CC-E5570-00	10 - 10	5WG-F1557-00	29 - 6		18 - 6	5LK-F3356-01	17 - 10
1CC-E2176-00	3 - 1	4S0-E4453-00	6 - 10	1CC-E5601-00	10 - 12	4S0-F1611-00	14 - 17		18 - 20		17 - 24
4KL-E2210-00	3 - 7	5WG-E4476-00	6 - 9	1CC-E5620-00	10 - 17	5WG-F1685-00	36 - 1	4KL-F3111-01	17 - 12		18 - 10
5MH-E2213-10	3 - 9	5WB-E4504-00	7 - 15	1CC-E5630-00	10 - 19	5MH-F1717-00	15 - 19		17 - 26		18 - 24
1CC-E2231-00	3 - 5	5WY-E4610-80	8 - 1	1CC-E5650-00	10 - 1	5WG-F1717-00	15 - 5		18 - 12	4KL-F3411-00	17 - 38
4KL-E2232-00	3 - 8	4KL-E4613-10	8 - 11	1CC-E5657-00	11 - 16	5WG-F171E-00-P1	15 - 15		18 - 26		18 - 38
1CC-E2241-00	3 - 6	5WY-E4617-00	8 - 7	1CC-E5659-00	10 - 21	5WG-F171E-00-P2	15 - 15	4S0-F3126-01	17 - 3	4FP-F3411-10	17 - 32
1CC-E2611-00	4 - 13	1CC-E4651-00	1 - 4	1CC-E5673-00	10 - 20	5WG-F171E-00-P9	15 - 15	4S0-F3126-11	18 - 3		18 - 32
1CC-E2651-00	4 - 1	5WY-E4708-10	8 - 2	1CC-E6111-00	11 - 1	5WG-F171E-00-PB	15 - 15	4S0-F3136-00	17 - 17	4KL-F3412-00	18 - 35
1CC-E2652-00	4 - 5	4KL-E4737-00	8 - 10	1CC-E6611-01	11 - 5	5WG-F171E-00-PC	15 - 15	4S0-F3136-10	18 - 17	4KL-F3412-20	17 - 35
1CC-E2658-00	4 - 8	5WY-E4759-01	8 - 6	1CC-E6620-00	11 - 20	5WG-F171E-00-UG	15 - 15	5WG-F3141-00	17 - 7	4KL-F3412-30	17 - 37
1CC-E2659-00	4 - 9	5WB-E4766-10	8 - 3	1CC-E6626-00	11 - 21	5WG-F171L-02-C1	15 - 18		17 - 21		18 - 37
1CC-E2668-00	4 - 10	5WY-E4779-01	8 - 4	1CC-E7211-00	12 - 6	5WG-F171L-02-P2	15 - 18	4P7-F3141-10	18 - 7	5MH-F3416-01	17 - 40
1CC-E3300-00	5 - 1	5WB-E4803-11	8 - 20	1CC-E7410-00	12 - 1	5WG-F171L-02-P8	15 - 18		18 - 21		18 - 40
1CC-E3324-00	2 - 4	5WG-E4806-01	8 - 25	1CC-E7421-00	12 - 5	5WG-F171L-02-P9	15 - 18	4GU-F3145-00	17 - 4	5WG-F3418-01	17 - 43
1CC-E3325-00	5 - 2	5WG-E4815-00	8 - 16	1CC-E7601-00	11 - 7	5WG-F171L-02-PC	15 - 18		17 - 18		18 - 43
4KL-E3411-01	5 - 10	5WY-E4872-30	8 - 15	1CC-E7602-00	11 - 19	5WG-F171M-02-C1	15 - 22		18 - 4	5WG-F341E-00	17 - 36
1CC-E3416-00	9 - 13	4S0-E4883-00	8 - 18	1CC-E7611-00	11 - 14	5WG-F171M-02-P2	15 - 22		18 - 18		18 - 36
1CC-E3451-00	2 - 3	4S0-E4884-00	8 - 22	1CC-E7620-00	11 - 8	5WG-F171M-02-P8	15 - 22	5AP-F3147-00	17 - 13	5WG-F341E-10	17 - 39
5MH-E3475-00	5 - 7	4S5-E4885-00	8 - 28	1CC-E7623-00	11 - 10	5WG-F171M-02-P9	15 - 22		17 - 27		18 - 39
4S0-E3542-10	8 - 23	5WB-E490A-10	7 - 16	1CC-E7632-00	11 - 9	5WG-F171M-02-PC	15 - 22		18 - 13	4GU-F3462-00	17 - 31
1CC-E3556-00	6 - 22	5WB-E490J-30	7 - 2	1CC-E7641-00	11 - 13	5WG-F1731-00-P1	15 - 11		18 - 27		18 - 31
1CC-E3569-00	4 - 11	5WB-E490K-10	7 - 3	1CC-E7653-00	11 - 11	5WG-F1731-00-P2	15 - 11	5AP-F3153-00	17 - 5	4TU-F3479-00	17 - 11

零件号码索引
NUMERICAL INDEX

零件号码 PART NO.	参照 号码	零件号码 PART NO.	参照 号码	零件号码 PART NO.	参照 号码	零件号码 PART NO.	参照 号码	零件号码 PART NO.	参照 号码	零件号码 PART NO.	参照 号码
4TU-F3479-00	17 - 25	3D9-F580U-01	23 - 3	5WG-F7481-00	28 - 7	5WY-H3922-01	37 - 7	4S0-X2171-31-UG	15 - 1	90159-06811	14 - 2
	18 - 11	5WG-F582U-20	23 - 1	5WG-F7483-00	28 - 19	4S0-H3963-01	37 - 3	4S0-X2172-21-P0	15 - 7	90159-06856	29 - 4
	18 - 25	4KL-F5852-00	27 - 5	4KL-F8100-01	20 - 19		38 - 4	4S0-X2172-21-P9	15 - 7	90170-05801	1 - 16
4P7-F3843-00	18 - 34	4KL-F5854-00	27 - 3	5WG-F8257-01	29 - 3	4S0-H3975-01	37 - 4	4S0-X2172-21-PB	15 - 7	90170-12181	31 - 5
4S0-F4110-01	19 - 1	4KL-F585B-00	27 - 4	4S0-F8300-01	29 - 1		38 - 5	4S0-X2172-21-PC	15 - 7	90170-28802	11 - 29
4S0-F4112-00	19 - 18	4KL-F5867-00	27 - 8	4KL-F8349-10	29 - 10	1CC-H3980-00	37 - 5	4S0-X2172-31-P0	15 - 7	90176-08811	1 - 31
4S0-F4135-00	19 - 22	4KL-F5870-21	27 - 1	5WG-F8365-00	38 - 2		38 - 6	4S0-X2172-31-P3	15 - 7	90179-06843	25 - 15
5WG-F414A-00	19 - 12	4P7-F5872-01	27 - 10	5WY-H1410-11	31 - 2	5MH-H3980-11	38 - 8	4S0-X2172-31-P9	15 - 7		25 - 22
1CC-F4170-00	19 - 24	4P7-F5875-01	18 - 46	5WY-H1450-01	31 - 1	4P7-H4310-02	35 - 1	4S0-X2172-31-UG	15 - 7		26 - 19
18C-F4180-00	19 - 21	5WG-F5886-01	18 - 48	4S0-H1800-10	32 - 1	4P7-H4312-00	35 - 3	4S0-X2473-20	20 - 4	90179-06850	8 - 12
4S0-F4311-11	19 - 7	5WG-F5887-02	18 - 47	4RT-H1801-00	32 - 2	4P7-H4314-00	35 - 5	5WG-X2534-00	21 - 14	90179-10817	11 - 6
4S0-F4312-10	19 - 10	4KL-F5896-00	27 - 7	5WV-H1828-01	32 - 4	4P7-H4347-00	35 - 2		24 - 6	90179-25810	17 - 41
4S0-F4313-00	19 - 20	4KL-F589H-01	27 - 6	4S0-H183G-00	32 - 3	4P7-H4396-00	35 - 4	4S0-X2610-02-P1	30 - 1		18 - 41
4S0-F4314-00	19 - 23	4S5-F5917-00	23 - 12	5WG-H1940-30	39 - 4	4P7-H4540-01	36 - 8	4S0-X2610-02-P2	30 - 1	90183-05818	14 - 8
4S0-F4315-00	19 - 27	4S5-F5919-00	23 - 11	5WG-H1952-10	39 - 5	4P7-H4700-03	36 - 7	4S0-X2610-02-P9	30 - 1		14 - 15
5WG-F4500-01	19 - 4	4S5-F5921-01	23 - 8	5WY-H1960-10	39 - 2	4P7-H4714-00	36 - 14	4S0-X2610-02-UG	30 - 1		15 - 4
4S0-F4610-01	19 - 2	4S5-F5924-01	23 - 13	4KL-H2100-00	39 - 9	4P7-H4723-00	36 - 11	4S0-X2610-11-P2	30 - 1		15 - 9
5WY-F4633-00	19 - 3	4S5-F5925-00	23 - 14	5WG-H2115-00	39 - 10	4P7-H4724-00	36 - 12	4S0-X2610-11-P9	30 - 1		15 - 17
5WG-F4726-00	20 - 5	4S5-F5937-00	23 - 9	5WG-H2129-00	28 - 11	4P7-H4726-00	36 - 17	4S0-X2610-11-PA	30 - 1		28 - 13
5WG-F4730-03	20 - 1	4S5-F5939-00	23 - 10	4KL-H2151-10	39 - 12	4P7-H4735-00	36 - 13	4S0-X2610-11-PB	30 - 1		30 - 2
16D-F473J-01	28 - 17	4S0-F6110-00	25 - 1	4KL-H2170-10	39 - 11	4P7-H4743-00	36 - 16	4S0-X8231-30	40 - 1		36 - 6
4S0-F473R-01	20 - 7	4S0-F6110-11	26 - 1	4S0-H2310-10	40 - 2	4P7-H4746-00	36 - 18	1CC-X8250-01	39 - 13		36 - 19
5WY-F4742-00	20 - 9	5WG-F6113-00	25 - 2	4S0-H2370-00	40 - 3	4P7-H5130-01	36 - 4	5WG-X8575-10	40 - 9	90185-14807	24 - 4
5WG-F475M-00	20 - 2		26 - 2	4FP-H2371-00	40 - 4	4KL-H5131-12	29 - 11	90101-06046	21 - 22	90201-06814	8 - 8
5WY-F4780-01	20 - 10	4P7-F6145-00	30 - 3	4KL-H2372-00	40 - 5	5WY-H5540-21	39 - 6		24 - 13	90201-07076	21 - 10
5WG-F478E-01	20 - 12	5MH-F6199-00	29 - 13	4S0-H2373-00	40 - 6	4S0-H5546-00	39 - 1	90101-10809	16 - 3	90201-07811	5 - 5
4S0-F4842-00	20 - 14	5WG-F6199-00	28 - 10	4S0-H2590-30	39 - 16	1CC-H5700-00	39 - 7	90105-08861	16 - 2	90201-08043	20 - 16
4KL-F5121-00-35	21 - 7	4S0-F6240-00	25 - 7	4P7-H3310-12	33 - 1	5WG-H5752-01	40 - 10	90105-10839	25 - 3		20 - 18
5WG-F5135-00	21 - 8		26 - 7	4P7-H3311-10	33 - 2	4KL-H5753-00	40 - 11		26 - 3	90201-08827	1 - 30
4KL-F5136-00	21 - 11	4KL-F6241-20	25 - 6		33 - 6	3D9-W0041-02	27 - 2	90109-06255	38 - 10	90201-108A3	10 - 4
	34 - 7		26 - 6	4P7-H331E-00	33 - 3	4S5-W0045-00	23 - 6	90109-06822	20 - 8	90201-108J9	27 - 12
5WG-F5138-00	21 - 9	4P7-F6270-01	25 - 8	4P7-H3320-12	33 - 5	4S5-W0047-00	23 - 5		36 - 2	90201-12172	9 - 46
	21 - 18		26 - 8	4P7-H332E-00	33 - 7	4S5-W0048-01	23 - 7	90109-08836	28 - 21	90201-15816	12 - 4
4KL-F5151-01	21 - 17	4S0-F6280-02	30 - 7	4P7-H3331-00	36 - 15	4S5-W0057-00	23 - 4	90113-06804	1 - 5	90201-15838	10 - 15
4KL-F5155-01	21 - 19	4S0-F6290-02	30 - 6	4P7-H333L-00	36 - 9	1CC-X1111-00	1 - 1	90116-06805	1 - 6	90201-17804	13 - 5
4KL-F5159-00	21 - 21	4S0-F6301-00	25 - 10	4P7-H333M-00	36 - 10	1CC-X1543-00	9 - 43	90116-08811	1 - 41	90201-20819	24 - 5
4S5-F5168-01-35	22 - 1		26 - 10	5WG-H3350-00	39 - 21	4S0-X2142-10	13 - 2	90119-05802	40 - 12	90202-05193	19 - 6
4KL-F5168-30-35	21 - 1	5WG-F6341-01	25 - 14	5WG-H3371-10	39 - 22	4S0-X2150-10-P2	14 - 1	90119-06157	14 - 12	90202-15804	28 - 3
5WG-F5181-01	21 - 27	4S0-F6351-01	25 - 17	4S0-H3510-01	34 - 1	4S0-X2150-10-P9	14 - 1		28 - 8	90202-26142	17 - 42
5WG-F5181-21	22 - 10		26 - 14	5WG-H3517-00	34 - 3	4S0-X2150-10-PA	14 - 1	90119-068A3	14 - 7		18 - 42
4P7-F5190-00	22 - 12	4KL-F637G-01	25 - 18	5WG-H3517-10	34 - 4	4S0-X2150-10-PB	14 - 1	90119-08839	20 - 17	90202-26801	32 - 8
5WG-F5315-00	21 - 4		26 - 15	5WG-H3517-V0	34 - 2	4S0-X2171-21-P0	15 - 1	90149-06108	19 - 5	90208-12050	11 - 17
	22 - 3	4S0-F7111-00	28 - 1	5WG-H3550-01	34 - 6	4S0-X2171-21-P9	15 - 1	90149-06827	28 - 16	90208-21802	12 - 7
5WG-F5326-01	24 - 14	5WG-F7113-01	28 - 4	5WG-H3550-11	34 - 6	4S0-X2171-21-PB	15 - 1	90149-08814	23 - 2	90214-14804	11 - 15
4KL-F5338-10-35	24 - 1	4S0-F7151-00	28 - 15	4S0-H3836-00	39 - 8	4S0-X2171-21-PC	15 - 1	90153-06803	1 - 2	90241-10801	20 - 6
5WY-F533A-01	24 - 11	4S0-F7180-01	28 - 14	5WY-H3912-11	37 - 1	4S0-X2171-31-P0	15 - 1	90157-05812	37 - 2	90249-12806	25 - 16
5WY-F5351-01	24 - 9	4S0-F7311-00	28 - 20		38 - 1	4S0-X2171-31-P3	15 - 1		37 - 8		25 - 21
5WY-F5355-01	24 - 12	4KL-F7314-00	28 - 2	4S0-H3922-00	38 - 9	4S0-X2171-31-P9	15 - 1		38 - 2		26 - 18

零件号码索引
NUMERICAL INDEX

零件号码 PART NO.	参照 号码	零件号码 PART NO.	参照 号码	零件号码 PART NO.	参照 号码	零件号码 PART NO.	参照 号码	零件号码 PART NO.	参照 号码	零件号码 PART NO.	参照 号码
90280-03045	2 - 5	90501-43804	11 - 27	93210-44678	32 - 6	95602-12200	21 - 28	97702-50016	15 - 10		
90340-12806	9 - 45	90506-12001	21 - 15	93210-44808	1 - 29		22 - 9		15 - 21		
90380-15806	10 - 14		24 - 7	93210-62802	1 - 26	95702-06500	6 - 3		15 - 24		
90387-068J2	8 - 26	90506-15001	21 - 16	93211-02802	9 - 33		8 - 17		25 - 5		
	19 - 26		24 - 8	93306-003X8	10 - 8		8 - 27		26 - 5		
90387-068K5	4 - 2	90506-20816	28 - 23	93306-200X0	11 - 4		19 - 25		29 - 2		
90387-125J1	22 - 11	90506-35820	28 - 6		12 - 3		20 - 3		30 - 4		
90387-12825	22 - 2	90508-26801	21 - 20	93306-201X4	21 - 6	95702-10500	16 - 4		33 - 4		
90387-12853	31 - 4	90508-32804	10 - 13		22 - 6		24 - 15		33 - 8		
90387-128M1	21 - 26	90560-12138	21 - 3	93306-204XC	12 - 9	95802-06010	17 - 45		34 - 5		
90387-16806	10 - 11	91312-06012	1 - 19	93306-205XY	2 - 2		18 - 45		35 - 6		
90387-16816	11 - 12	91312-06016	3 - 10	93306-253Y0	11 - 2		20 - 11	97702-60530	4 - 7		
90401-10823	27 - 11	91312-06020	32 - 9		12 - 11	95802-06012	8 - 21	98501-04008	7 - 5		
90413-12800	9 - 8	91312-06025	10 - 18	93306-301XJ	21 - 2		13 - 17	98502-03006	37 - 6		
90430-06014	1 - 3	91312-06090	1 - 36		22 - 5		18 - 49		38 - 7		
	9 - 30	91312-08016	20 - 15	93311-315X0	12 - 2		29 - 9	98502-05010	25 - 11		
90430-08119	9 - 15	91808-12804	9 - 35	93317-110Y4	10 - 2	95802-06014	13 - 15		26 - 11		
90450-45801	6 - 19	91810-14805	1 - 34	93410-20823	12 - 8		19 - 15	98502-05012	20 - 13		
90464-08020	4 - 12		1 - 35	93450-15825	2 - 8	95812-08016	3 - 3		28 - 18		
90464-12812	39 - 17		9 - 10	93602-12801	5 - 4		9 - 14	98502-05020	25 - 9		
90464-20809	25 - 13		9 - 20	93603-12802	5 - 3	95812-08030	8 - 14		26 - 9		
	26 - 13		9 - 24	93900-00827	21 - 24	95812-08050	8 - 13	98502-06010	39 - 23		
	39 - 18	91A11-07042	19 - 14		22 - 7	95812-10030	13 - 13	98502-06012	10 - 6		
90464-23811	39 - 20	92012-05010	25 - 12		24 - 2	95812-10035	28 - 5		25 - 19		
90465-12803	4 - 6		26 - 12	94101-12302	17 - 34	97522-06512	1 - 24		26 - 16		
90465-13152	39 - 19	92012-06025	27 - 9	94110-10810	21 - 25	97601-04014	7 - 12		39 - 3		
	40 - 8	93102-17808	11 - 3		22 - 8	97602-05212	39 - 14		39 - 15		
90467-08003	19 - 11	93102-17853	21 - 5	94110-10816	24 - 3	97602-05216	30 - 5	98502-06016	31 - 3		
	19 - 28		22 - 4	94568-A2084	3 - 4	97602-06214	4 - 14	98502-06018	40 - 7		
90467-08070	8 - 24	93102-19805	9 - 31	94700-00869	1 - 32	97602-06220	6 - 12	98502-06020	4 - 3		
90467-09006	19 - 8	93102-19810	9 - 32	95022-06020	1 - 27	97602-06225	6 - 20	98702-06020	5 - 8		
	19 - 19	93102-22811	9 - 12		9 - 36		31 - 6	98902-05008	32 - 7		
90467-10008	19 - 9	93102-26852	12 - 10	95022-06030	9 - 21	97702-50012	14 - 3	98902-06010	9 - 28		
90467-12802	19 - 16	93104-07803	21 - 12	95022-06035	9 - 25		14 - 9	98902-06020	9 - 42		
90467-12814	6 - 18	93106-47814	21 - 13	95022-06070	9 - 11		14 - 16	98980-06020	8 - 9		
	9 - 7	93109-33803	11 - 24	95022-10030	23 - 15		15 - 2	99001-05600	5 - 6		
90467-13804	1 - 40	93210-07809	9 - 34	95302-06600	21 - 23		15 - 8	99009-15400	10 - 16		
90467-13815	6 - 17	93210-07890	24 - 16	95302-12700	11 - 18		15 - 12	99009-17400	13 - 6		
90467-13817	6 - 13	93210-09859	24 - 10	95602-05100	37 - 9		15 - 14	99009-35700	10 - 9		
90467-16805	8 - 19	93210-14104	34 - 8		38 - 3		15 - 20				
90467-16808	8 - 29	93210-14815	9 - 17	95602-05200	29 - 12		15 - 23				
90480-12803	14 - 18	93210-15171	3 - 11		36 - 5		28 - 9				
90480-14023	36 - 20	93210-15639	13 - 4	95602-06100	38 - 11		28 - 12				
90480-30800	4 - 4	93210-23614	32 - 5	95602-08200	28 - 22		36 - 3				
90501-10312	38 - 12	93210-25806	6 - 2	95602-10200	13 - 9	97702-50016	14 - 5				
90501-16829	5 - 11	93210-26812	9 - 38		13 - 12		14 - 10				
90501-16831	25 - 20	93210-34803	5 - 12		25 - 4		14 - 14				
	26 - 17	93210-36800	11 - 25		26 - 4		15 - 3				

雅马哈纯正机油大集结



纯正机油

品质保证! 动力之源!

请经销YAMALUBE纯正 机油!



90793-AC421-T1
90793-AC421-G1
SAE 10W-40 (1L)
高等级/通用



90793-AC422-00
SAE 10W-30 (1L)
跨骑车专用



90793-AC423-T1
90793-AC423-G1
SAE 20W-40 (1L)
跨骑车专用



90793-AC427-T1
90793-AC427-G1
SAE 10W-40 (0.8L)
弯梁车专用



90793-AC426-T1
SAE 5W-30 (1L)
冬季专用/通用



90793-AC424-00
SAE 10W-30 (1L)
踏板车专用



90793-AC425-T1
90793-AC425-G1
SAE 20W-40 (1L)
踏板车专用



90793-AC404
GEAR (0.13L)
齿轮油
踏板车专用

友情提示：磨合期后，建议每1500KM更换一次机油(可根据实际使用状况减少里程数)。并清洗机油滤网。