

翻印必究



上海雅马哈建设摩托车销售有限公司

<http://www.yamaha-motor.com.cn/>

第一版 2013年6月



SHANGHAI YAMAHA JIANSHE MOTOR MARKETING CO., LTD.

零件目录

XA125 (4S5F)
XA125 (4S5G)
XA125 (4S5H)
XA125 (4S5J)

4S5-F8198-1M-M1

1M4S5-415M1

CYANUS Z

XA125 (4S5F)/XA125 (4S5G)/XA125 (4S5H)/XA125 (4S5J)



4S5F (手碟)

代号	颜色
00WL	星灰银



代号	颜色
00AL	宁静黄



代号	颜色
0775	金属蓝



代号	颜色
0632	亮金属红5



代号	颜色
0903	金属黑



4S5G (脚碟)

代号	颜色
00WL	星灰银



代号	颜色
00AL	宁静黄



代号	颜色
0775	金属蓝



代号	颜色
0632	亮金属红5



代号	颜色
0903	金属黑



4S5H (手碟)

代号	颜色
0582	亚光黑2



4S5H (手碟)

代号	颜色
0390	带蓝混合白1



4S5J (脚碟)

代号	颜色
0582	亚光黑2



4S5J (脚碟)

代号	颜色
0390	带蓝混合白1



前言

本零件目录记载着封面页所示型号所使用的零件。当您订购更换零件时，请参阅本零件目录并正确指示零件号码和零件名称。

1. 零件目录发行后有变更或附加零件时，将会以雅马哈零件信息通知大家。
建议您应按照雅马哈零件信息修改本零件目录。

2. 省略记号
本文中所记载的省略记号的意思如下。

“UR” 需要指定的零件号码。

“UN” 需要数。

“AP” 选购品

“LM” 当地制造（必需于当地订购的零件）

“F#” 车架号（适用的机器号）

“O/S” 超过尺寸

3. 组件中部件的数量

- 组件的销售零件，如下所示，在零件名称的前面加上（.）的记号来表示。
- 每个部件右侧的数字表示各组件单体内该部件的数量。

零件号码	零件名称	数量	备注
2F5 - 83310 - 60	前闪光灯组合	2	
115 - 83311 - 60	. 灯泡 (6V - 18W)	1	

4. 适用的图形颜色表示在“备注”中，如下所示。

零件号码	零件名称	数量	备注
2N4 - 24110 - 00 - X5	燃油箱组件	2	MXR
3J1 - 24240 - 10	. 燃油箱图形	1	适用于 MXR

5. 请注意插图只用于找寻零件号码时参照，并不适用于组装。组装时，请使用适用的维修手册。

6. 在参照号码前的星号（*）表示其为在第一版后更改的项目。

前言

7. 适用的系列号码

车架系列号

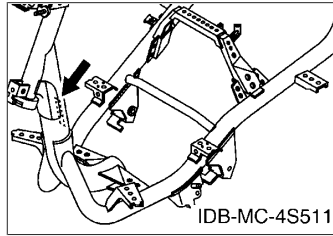

发动机系列号码

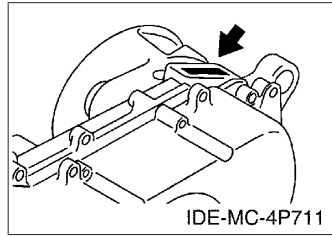

8. 适用的颜色记号 (*标志表示型号颜色。)

省略记号	颜色名称 (英文)	颜色名称	颜色记号
BMC(*)	BLUE METALLIC C	金属蓝	0775
BWC1(*)	BLUISH WHITE COCKTAIL 1	浅蓝鸡尾白色 1	0390
CMY(*)	CALM YELLOW	黄	00AL
LGB	LOW GLOSS BLACK	黑色	0098
MBL2(*)	MAT BLACK 2	无光泽黑	0582
MBM3	MAT BLUE METALLIC 3	无光泽金属蓝	0960
MNYM1	MAT GRAYISH YELLOW METALLIC 1	无光泽浅灰金属黄	1199
SMX(*)	BLACK METALLIC X	金属黑色	0903
STDS(*)	STARDUST SILVER	幻银	00WL
VRM5(*)	VIVID RED METALLIC 5	亮金属红	0632

9. 适用的初始系列号码

车架系列号

系列号码	数量栏名称	型号记号

发动机系列号码

系列号码	数量栏名称	型号记号

型号信息

10. 颜色信息

型号代码	颜色类型代码	颜色记号	颜色名称 (英文)	颜色名称	省略记号
4S5F, 4S5G	A	00WL	STARDUST SILVER	幻银	STDS
	B	00AL	CALM YELLOW	黄	CMY
	C	0775	BLUE METALLIC C	金属蓝	BMC
	D	0632	VIVID RED METALLIC 5	亮金属红	VRM5
	E	0903	BLACK METALLIC X	金属黑色	SMX
4S5H, 4S5J	A	0582	MAT BLACK 2	无光泽黑	MBL2
	B	0390	BLUISH WHITE COCKTAIL 1	浅蓝鸡尾白色 1	BWC1

目录

发动机

气缸头.....	1
曲柄·活塞.....	3
凸轮轴·链条.....	4
空气罩&风扇.....	5
油泵.....	6
进气门.....	7
化油器.....	8
排气装置.....	10
曲轴箱.....	12
起动机.....	14
离合器.....	15
传动.....	17

车体

车架.....	18
挡泥板.....	19
侧盖.....	20
后悬挂.....	21
前叉.....	22
油箱.....	24
座位.....	25
前轮.....	26
前制动器卡钳.....	27
后轮.....	28
操纵手柄·钢索.....	29
前主缸.....	30
搁脚·支架.....	31
护腿.....	34
手把杆上侧盖.....	36
发电机.....	37
起动机.....	38
转向灯.....	39
仪表.....	40
前大灯.....	41
尾灯.....	42
手柄开关·杆.....	43
电气系统 1.....	44
电气系统 2.....	45

索引

零件号码索引.....	46
-------------	----

CONTENTS

ENGINE

CYLINDER HEAD.....	1
CRANKSHAFT & PISTON.....	3
CAMSHAFT & CHAIN.....	4
AIR SHROUD & FAN.....	5
OIL PUMP.....	6
INTAKE.....	7
CARBURETOR.....	8
EXHAUST.....	10
CRANKCASE.....	12
STARTER.....	14
CLUTCH.....	15
TRANSMISSION.....	17

CHASSIS

FRAME.....	18
FENDER.....	19
SIDE COVER.....	20
REAR SUSPENSION.....	21
FRONT FORK.....	22
FUEL TANK.....	24
SEAT.....	25
FRONT WHEEL.....	26
FRONT BRAKE CALIPER.....	27
REAR WHEEL.....	28
STEERING HANDLE & CABLE.....	29
FRONT MASTER CYLINDER.....	30
STAND & FOOTREST.....	31
LEG SHIELD.....	34
COVER.....	36
GENERATOR.....	37
STARTING MOTOR.....	38
FLASHER LIGHT.....	39
METER.....	40
HEADLIGHT.....	41
TAILLIGHT.....	42
HANDLE SWITCH & LEVER.....	43
ELECTRICAL 1.....	44
ELECTRICAL 2.....	45

INDEX

NUMERICAL INDEX.....	46
----------------------	----

FIG. 1 气缸头

CYLINDER HEAD

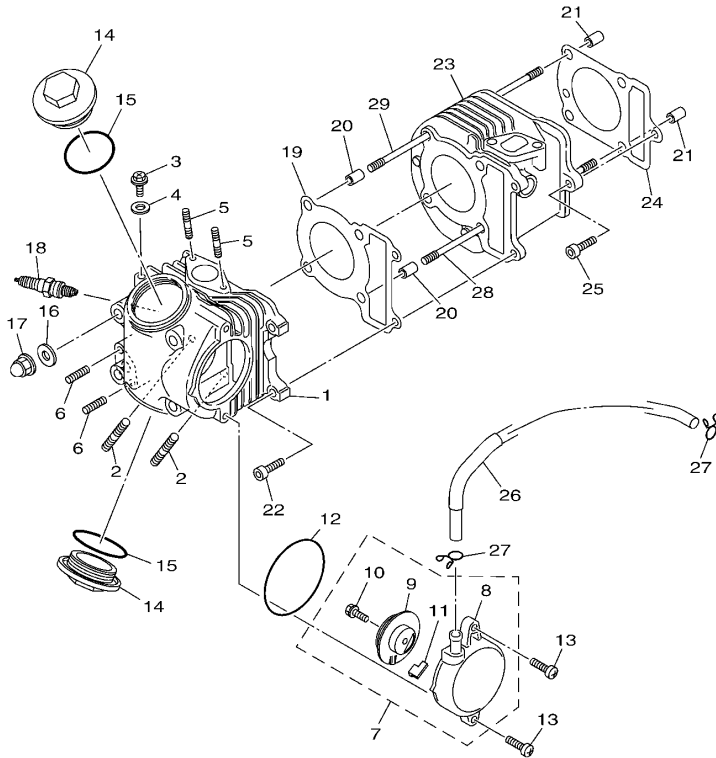

4S5F415-M010

参照 号码	零件号码 PART NO.	零件名称 DESCRIPTION	4SF	4SG	4SH	4SJ	备注 REMARKS
1	4S5-E1111-10	气缸头 1 HEAD, CYLINDER 1	1	1	1	1	
2	90116-08019	双头螺栓 BOLT, STUD	2	2	2	2	
3	90153-06803	六角头螺钉 SCREW, HEXAGON	1	1	1	1	
4	90430-06014	衬垫 GASKET	1	1	1	1	
5	95612-06625	双头螺栓 BOLT, STUD	2	2	2	2	
6	90113-06804	离合杆螺栓 BOLT, SET	2	2	2	2	
7	4S5-E1160-02	通气管组合 BREATHER ASSY	1	1	1	1	
8	4S5-E1185-01	气缸头侧盖 3 COVER, CYLINDER HEAD SIDE 3	1	1	1	1	
9	5WG-E1165-00	通气管面板 PLATE, BREATHER	1	1	1	1	
10	97522-06512	带垫螺栓 BOLT, WITH WASHER	1	1	1	1	
11	5WG-E1155-00	曲折环式密封圈 SEAL, LABYRINTH	1	1	1	1	
12	93210-71462	O型环 O-RING	1	1	1	1	
13	98502-06020	十字螺钉 SCREW, PAN HEAD	2	2	2	2	
14	4KL-E1186-00	气缸头侧盖 2 COVER, CYLINDER HEAD SIDE 2	2	2	2	2	
15	93210-448C2	O型环 O-RING	2	2	2	2	
16	90201-08609	平垫圈 WASHER, PLATE	4	4	4	4	
17	90176-08811	盖型螺母 NUT, CROWN	4	4	4	4	
18	94700-00876	火花塞 PLUG, SPARK (NGK CR7E)	1	1	1	1	
19	5WG-E1181-01	气缸头衬垫 1 GASKET, CYLINDER HEAD 1	1	1	1	1	
20	99530-10114	定位销 PIN, DOWEL	2	2	2	2	
21	99530-10114	定位销 PIN, DOWEL	2	2	2	2	
22	91312-06025	螺栓 BOLT	2	2	2	2	
23	5WG-E1310-01	气缸 CYLINDER	1	1	1	1	
24	5WG-E1351-10	气缸衬垫 GASKET, CYLINDER	1	1	1	1	
25	91312-06025	螺栓 BOLT	1	1	1	1	
26	4S5-E4987-00	软管 HOSE	1	1	1	1	
27	90467-13804	卡环 CLIP	2	2	2	2	

FIG. 1 气缸头

CYLINDER HEAD

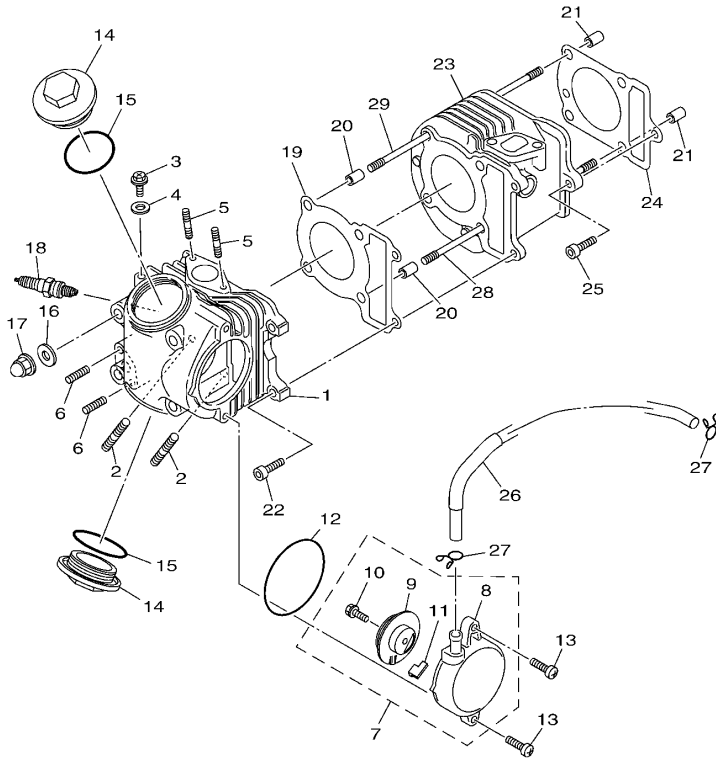



4S5F415-M010

参照 号码	零件号码 PART NO.	零件名称 DESCRIPTION	4S5F	4S5G	4S5H	4S5J	备注 REMARKS
28	90116-08020	双头螺栓 BOLT, STUD	2	2	2	2	
29	90116-08020	双头螺栓 BOLT, STUD	2	2	2	2	

FIG. 2 曲柄·活塞

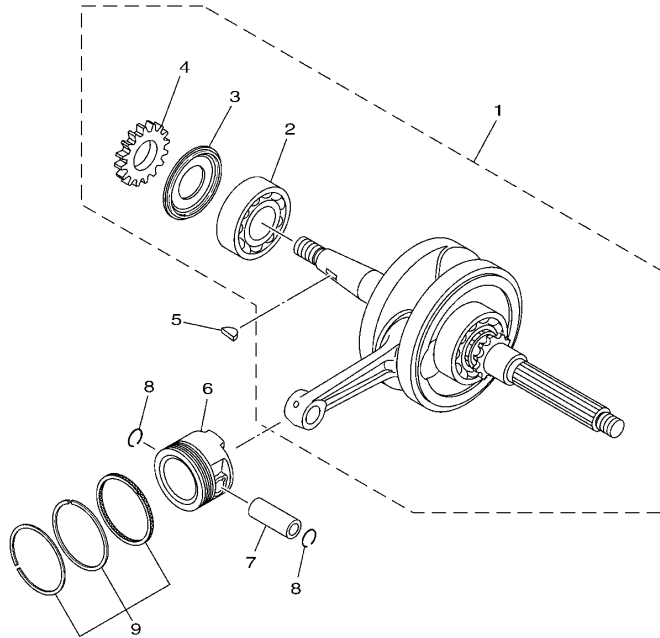
CRANKSHAFT & PISTON



参照 号码	零件号码 PART NO.	零件名称 DESCRIPTION	4SF6	4S5G	4S5H	4S5J	备注 REMARKS
1	5WG-E1400-60	曲轴组合 CRANKSHAFT ASSY	1	1			
	5WG-E1400-70	曲轴组合 CRANKSHAFT ASSY		1	1		
2	93306-205XY	.轴承 .BEARING	1	1	1	1	
3	4KL-E1445-00	.隔套 .SPACER	1	1	1	1	
4	4KL-E3324-00	.机油泵驱动齿轮 .GEAR, PUMP DRIVE	1	1	1	1	
5	90280-03045	半圆键 KEY, WOODRUFF	1	1	1	1	
6	4S5-E1631-00	活塞 (STD) PISTON (STD)	1	1	1	1	
7	1CC-E1633-10	活塞销 PIN, PISTON	1	1	1	1	
8	93450-14088	卡环 CIRCLIP	2	2	2	2	
9	5MH-E1603-00	活塞环套件 (STD) PISTON RING SET (STD)	1	1	1	1	

4S5B415-K020

FIG. 3 凸轮轴·链条

CAMSHAFT & CHAIN

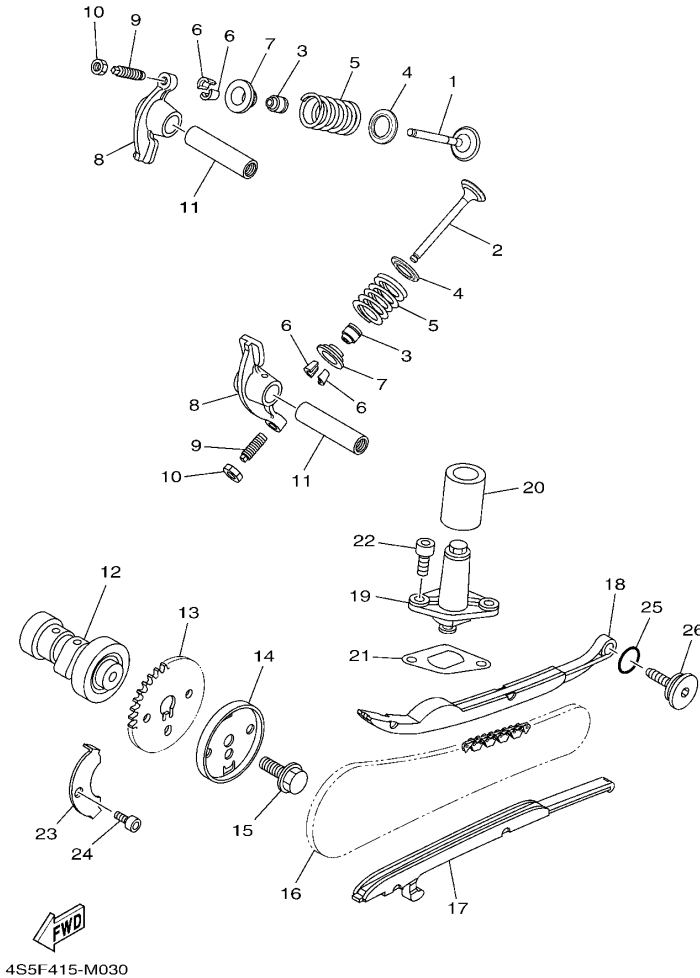

4S5F415-M030

参照 号码	零件号码 PART NO.	零件名称 DESCRIPTION	4SF	4SG	4SH	4SJ	备注 REMARKS
1	5WG-E2111-01	进气门 VALVE, INTAKE	1	1	1	1	
2	5WG-E2121-00	排气门 VALVE, EXHAUST	1	1	1	1	
3	5WG-E2119-00	气门油封 SEAL, VALVE STEM	2	2	2	2	
4	4S5-E2116-00	气门弹簧座 SEAT, VALVE SPRING	2	2	2	2	
5	5WG-E2113-00	气门内弹簧 SPRING, VALVE INNER	2	2	2	2	
6	5WG-E2118-00	气门锁夹 LOCK, VALVE SPRING RETAINER	4	4	4	4	
7	5WG-E2117-00	气门弹簧座 RETAINER, VALVE SPRING	2	2	2	2	
8	5WG-E2151-01	气门摇臂 ARM, VALVE ROCKER	2	2	2	2	
9	22F-12159-00	气门调整螺钉 SCREW, VALVE ADJUSTING	2	2	2	2	
10	90170-05302	螺母 NUT	2	2	2	2	
11	1CC-E2156-10	摇臂轴 2 SHAFT, ROCKER 2	2	2	2	2	
12	5WG-E2170-00	凸轮轴组合 1 CAMSHAFT ASSY 1	1	1	1	1	
13	5WG-E2176-00	链轮 SPROCKET, CAM CHAIN	1	1	1	1	
14	5WG-E1145-00	通气管面板 2 PLATE, BREATHER 2	1	1	1	1	
15	95812-08016	凸缘螺栓 BOLT, FLANGE	1	1	1	1	
16	94568-E8088	链条 CHAIN	1	1	1	1	
17	4KL-E2231-00	导向限位板 1 GUIDE, STOPPER 1	1	1	1	1	
18	4KL-E2241-00	导向限位板 2 GUIDE, STOPPER 2	1	1	1	1	
19	4KL-E2210-00	链条张紧器组合 TENSIONER ASSY, CAM CHAIN	1	1	1	1	
20	4KL-E2232-00	减震器 DAMPER	1	1	1	1	
21	5MH-E2213-10	张紧器垫片 GASKET, TENSIONER CASE	1	1	1	1	
22	91312-06016	螺栓 BOLT	2	2	2	2	
23	5WG-E1111F-00	面板 PLATE	1	1	1	1	
24	91312-06012	螺栓 BOLT	1	1	1	1	
25	93210-15171	O型环 O-RING	1	1	1	1	
26	5MH-E2157-01	锁紧螺母 BOLT	1	1	1	1	

FIG. 4 空气罩&风扇

AIR SHROUD & FAN

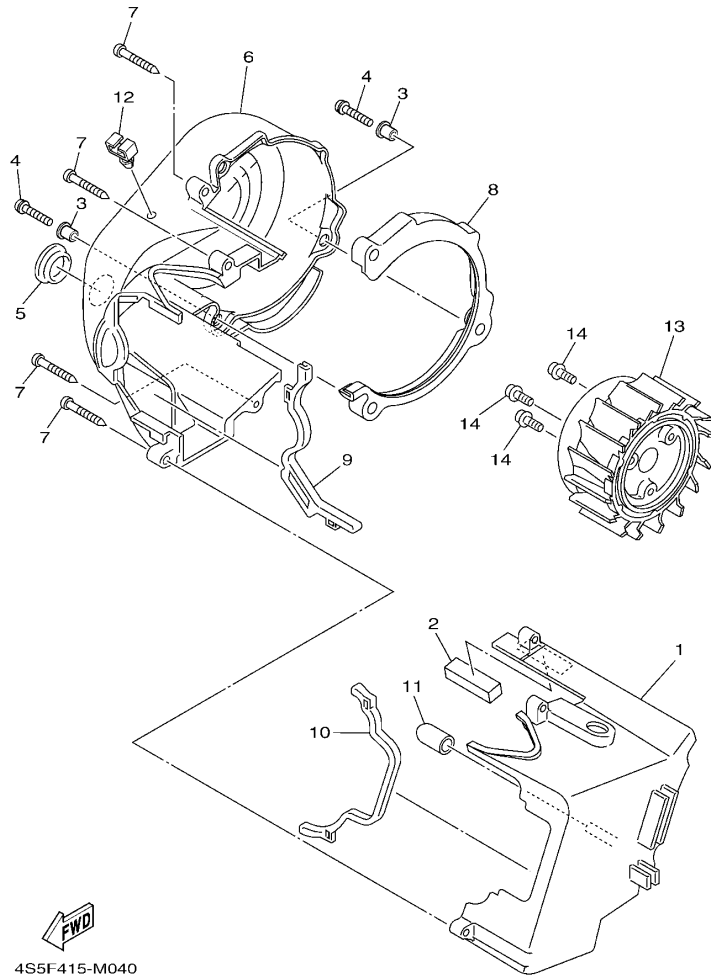

4S5F415-M040

参照 号码	零件号码 PART NO.	零件名称 DESCRIPTION	4SF	4SG	4SH	4SJ	备注 REMARKS
1	4P7-E2651-00	气缸空气罩 1 AIR SHROUD, CYLINDER 1	1	1	1	1	
2	5WG-E2669-00	空气罩挡板 4 DAMPER, AIR SHROUD 4	1	1	1	1	
3	90387-068J1	轴套 COLLAR	2	2	2	2	
4	97602-06220	带垫圈大柱头螺钉 SCREW, PAN HEAD W/WASHER	2	2	2	2	
5	90480-30167	橡胶垫 GROMMET	1	1	1	1	
6	4P7-E2652-00	气缸空气罩 2 AIR SHROUD, CYLINDER 2	1	1	1	1	
7	97702-60530	自攻螺钉 SCREW, TAPPING	4	4	4	4	
8	5WG-E2658-00	冷却风道避震垫 1 DAMPER, AIR SHROUD 1	1	1	1	1	
9	5WG-E2659-00	冷却风道避震垫 2 DAMPER, AIR SHROUD 2	1	1	1	1	
10	5WG-E2668-00	冷却风道避震垫 3 DAMPER, AIR SHROUD 3	1	1	1	1	
11	5MH-E3569-00	绝缘插头 PLUG, BLIND	1	1	1	1	
12	90464-08020	线夹 CLAMP	1	1	1	1	
13	4P7-E2611-00	风扇 FAN	1	1	1	1	
14	97602-06214	带垫圈大柱头螺钉 SCREW, PAN HEAD WITH WASHER	3	3	3	3	

FIG. 5 油泵

OIL PUMP

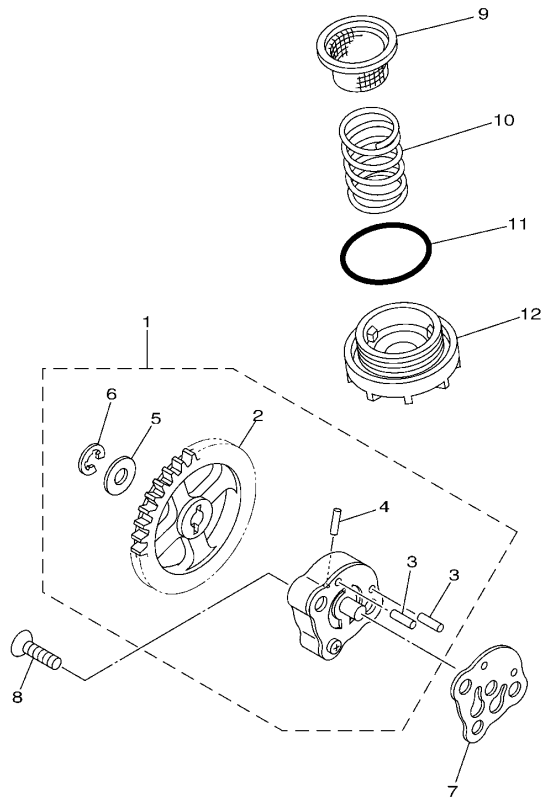

参照 号码	零件号码 PART NO.	零件名称 DESCRIPTION	4SF6	4S6G	4S6H	4S6J	备注 REMARKS
1	5MH-E3300-21	机油泵总成 OIL PUMP ASSY	1	1	1	1	
2	5MH-E3325-10	.从动齿轮 .GEAR, PUMP DRIVEN	1	1	1	1	
3	93603-12833	.定位销 .PIN, DOWEL	2	2	2	2	
4	93602-13832	.定位销 .PIN, DOWEL	1	1	1	1	
5	90201-077F5	.平垫圈 .WASHER, PLATE	1	1	1	1	
6	99001-05600	.卡环 .CIRCLIP	1	1	1	1	
7	5MH-E3475-00	衬垫 GASKET	1	1	1	1	
8	98702-06020	平头螺钉 SCREW, FLAT HEAD	2	2	2	2	
9	4KL-E3411-01	机油滤网 STRAINER, OIL	1	1	1	1	
10	90501-16829	压簧 SPRING, COMPRESSION	1	1	1	1	
11	93210-34803	O型环 O-RING	1	1	1	1	
12	4KL-E5351-10	放油塞 PLUG, DRAIN	1	1	1	1	

1CC1415-K051

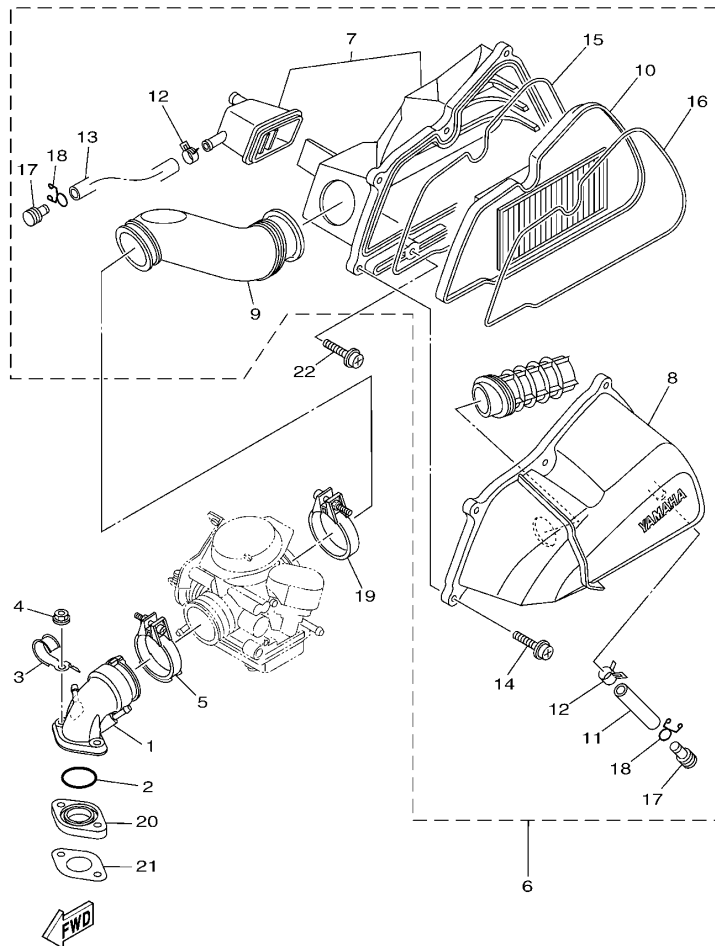

4S5B415-K060

FIG. 6 进气门

INTAKE

参照 号码	零件号码 PART NO.	零件名称 DESCRIPTION	4SFE	4S5G	4S5H	4S5J	备注 REMARKS
1	5WG-E3585-00	岐管 MANIFOLD	1	1	1	1	
2	93210-25806	O型环 O-RING	1	1	1	1	
3	90462-10803	夹箍 CLAMP	1	1	1	1	
4	95702-06500	螺母 NUT, FLANGE	2	2	2	2	
5	5MH-E3575-01	箍带 BAND	1	1	1	1	
6	4S5-E4410-01	空气净化装置组合 AIR CLEANER ASSY.	1	1	1	1	
7	4S5-WE441-02	空气净化装置箱组 AIR CLEANER CASE COMP.	1	1	1	1	
8	4S5-E4412-00	空气净化装置箱盖 1 CAP, CLEANER CASE 1	1	1	1	1	
9	4S5-E4453-00	空气净化装置接头 1 JOINT, AIR CLEANER 1	1	1	1	1	
10	4S5-E4451-01	空气滤芯 ELEMENT, AIR CLEANER	1	1	1	1	
11	5WG-E443E-01	排水管 PIPE, DRAIN	1	1	1	1	
12	90467-13817	卡环 CLIP	2	2	2	2	
13	4S5-E443E-00	排水管 PIPE, DRAIN	1	1	1	1	
14	97602-06220	带垫圈大柱头螺钉 SCREW, PAN HEAD W/WASHER	6	6	6	6	
15	4S5-E4467-00	密封圈 SEAL	1	1	1	1	
16	4S5-E4476-00	密封圈 SEAL	1	1	1	1	
17	90338-11820	塞 PLUG	2	2	2	2	
18	90467-12802	卡环 CLIP	2	2	2	2	
19	5WG-E3575-01	箍带 BAND	1	1	1	1	
20	5WG-E3595-00	接头 JOINT	1	1	1	1	
21	5WG-E3556-10	岐管衬垫 GASKET, MANIFOLD	1	1	1	1	
22	97602-06225	带垫圈大柱头螺钉 SCREW, PAN HEAD WITH WASHER	2	2	2	2	

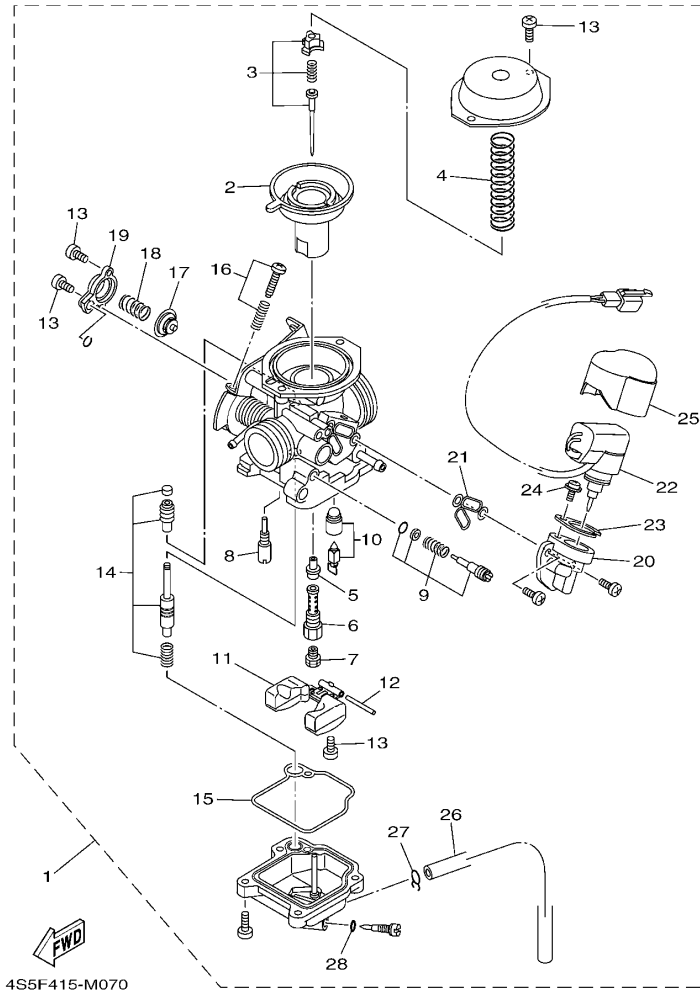

4S5F415-M070

FIG. 7 化油器

CARBURETOR

参照 号码	零件号码 PART NO.	零件名称 DESCRIPTION	4S5F	4S5G	4S5H	4S5J	备注 REMARKS
1	4S5-E4901-10	化油器总成 1 CARBURETOR ASSY 1	1	1	1	1	
2	4S5-E4940-00	.隔膜组合 .DIAPHRAGM ASSY	1	1	1	1	
3	4S5-E490J-10	.滚针套件 .NEEDLE SET	1	1	1	1	
4	5WG-E4933-00	.隔膜弹簧 .SPRING, DIAPHRAGM	1	1	1	1	
5	5WG-E4947-00	.针形量孔 .JET, NEEDLE	1	1	1	1	
6	5WG-E414G-00	.主排放管 .HOLDER	1	1	1	1	
7	5TY-E4943-28	.主量孔 (#105) .JET, MAIN (#105)	1	1	1	1	
8	4S5-E4948-00	.量孔 .JET	1	1	1	1	
9	4S5-E4105-00	.混合气调整螺钉组件 .PILOT SCREW SET	1	1	1	1	
10	5WG-E4107-00	.针阀套件 .NEEDLE VALVE SET	1	1	1	1	
11	5WG-E4985-00	.浮子 .FLOAT	1	1	1	1	
12	5WG-E4548-00	.浮子臂销 .PIN, FLOAT ARM	1	1	1	1	
13	5WG-E4592-00	.螺钉 .SCREW	5	5	5	5	
14	5WG-E4504-00	.杆套 .ROD SET	1	1	1	1	
15	1B6-E4984-00	.浮子室衬垫 .GASKET, FLOAT CHAMBER	1	1	1	1	
16	5WG-E490K-00	.止动螺钉套件 .STOP SCREW SET	1	1	1	1	
17	5WG-E490A-00	.隔膜套件 1 .DIAPHRAGM SET 1	1	1	1	1	
18	5WG-E4275-00	.弹簧 .SPRING	1	1	1	1	
19	5WG-E4958-00	.隔膜盖 .COVER, DIAPHRAGM	1	1	1	1	
20	5WG-E4907-00	.起动机 .BODY, STARTER	1	1	1	1	
21	5WG-E4147-00	.O型环 .O-RING	1	1	1	1	
22	5WG-E4370-00	.柱塞起动机组合 .PLUNGER STARTER ASSY	1	1	1	1	
23	5WG-E4243-00	.面板 .PLATE	1	1	1	1	
24	97607-04208	.带垫螺栓 .SCREW, WITH WASHER	1	1	1	1	
25	5WG-E4967-00	.罩 .COVER	1	1	1	1	
26	5WG-E4196-00	.溢流管 1 .PIPE, OVER FLOW 1	1	1	1	1	
27	4S5-E4137-00	.钢夹 .CLIP	1	1	1	1	

FIG. 7 化油器

CARBURETOR

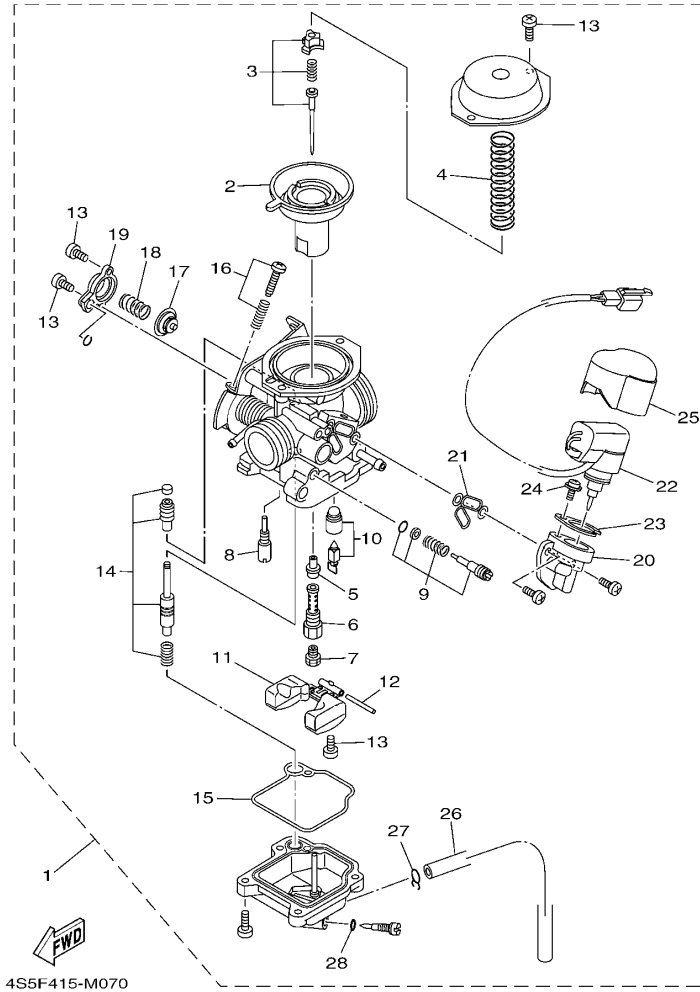

4S5F415-M070

参照 号码	零件号码 PART NO.	零件名称 DESCRIPTION	4S5F	4S5G	4S5H	4S5J	备注 REMARKS
28	4JH-14562-00	.0 型 .O-RING	1	1	1	1	

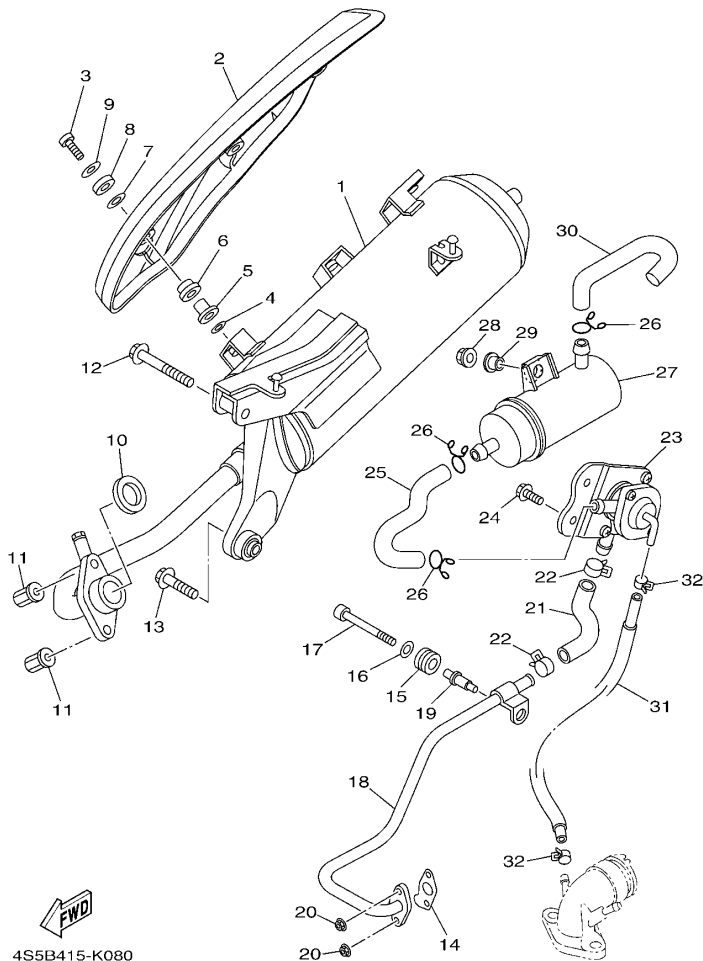

4S5B415-K080

FIG. 8 排气装置

EXHAUST

参照 号码	零件号码 PART NO.	零件名称 DESCRIPTION	4SFE	4SSG	4SHH	4SJ	备注 REMARKS
1	4S5-E4610-20	排气管组合 1 EXHAUST PIPE ASSY 1	1	1	1	1	
2	4S5-E4708-10	保护件组合 PROTECTOR ASSY	1	1	1	1	
3	98980-06020	螺钉 SCREW, BIND	3	3	3	3	
4	5WB-E4766-10	保护件垫圈 WASHER, PROTECTOR	3	3	3	3	
5	5WY-E4779-01	安装套 COLLAR	3	3	3	3	
6	5WY-E4445-00	固定套 GROMMET	3	3	3	3	
7	5WY-E4759-01	垫圈 WASHER	3	3	3	3	
8	5WY-E4617-00	垫圈 WASHER	3	3	3	3	
9	90201-06814	平垫圈 WASHER, PLATE	3	3	3	3	
10	4KL-E4613-10	排气管衬垫 GASKET, EXHAUST PIPE	1	1	1	1	
11	90179-08833	螺母 NUT	2	2	2	2	
12	95812-08050	凸缘螺栓 BOLT, FLANGE	1	1	1	1	
13	95812-08035	凸缘螺栓 BOLT, FLANGE	1	1	1	1	
14	5WG-E4815-00	衬垫 GASKET	1	1	1	1	
15	4S5-E4871-00	管 1 PIPE 1	1	1	1	1	
16	90480-15801	橡胶垫 GROMMET	1	1	1	1	
17	90201-06078	平垫圈 WASHER, PLATE	1	1	1	1	
18	91312-06050	螺栓 BOLT	1	1	1	1	
19	5WG-E4876-11	管 6 PIPE 6	1	1	1	1	
20	95702-06500	螺母 NUT, FLANGE	2	2	2	2	
21	5WG-E4883-10	弯曲软管 3 HOSE, BEND 3	1	1	1	1	
22	90467-16805	卡环 CLIP	2	2	2	2	
23	5WG-E4803-11	二次进气系统 AIR INDUCTION SYSTEM ASSY	1	1	1	1	
24	95802-06012	凸缘螺栓 BOLT, FLANGE	2	2	2	2	
25	5WG-E4884-10	弯曲软管 4 HOSE, BEND 4	1	1	1	1	
26	90467-16808	卡环 CLIP	3	3	3	3	
27	5WG-E4806-11	空气滤芯器 AIR FILTER	1	1	1	1	

FIG. 8 排气装置

EXHAUST

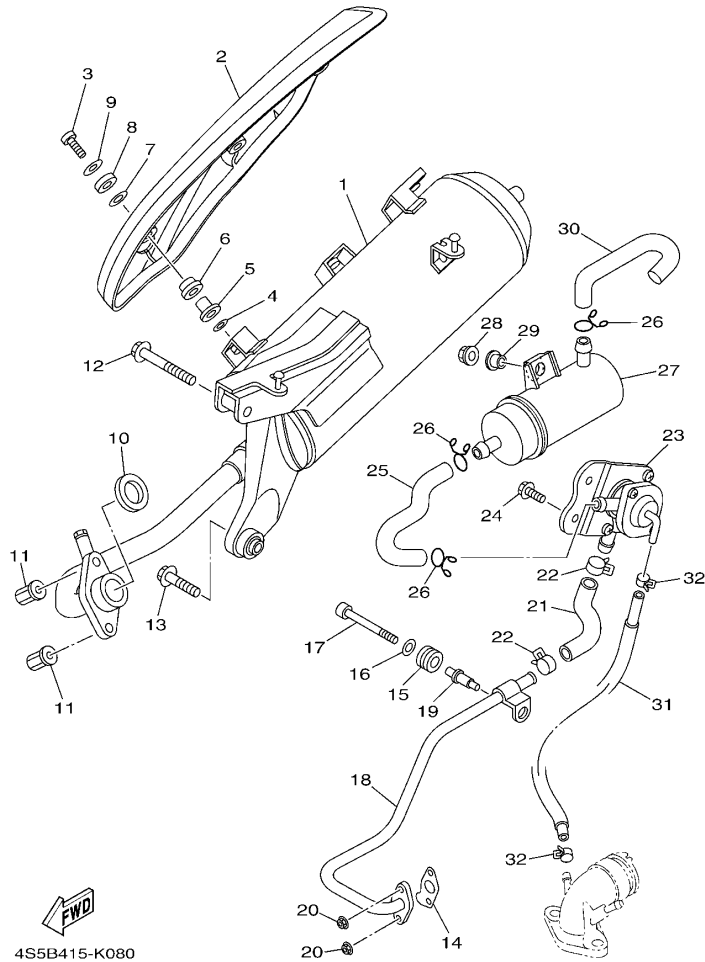

参照 号码	零件号码 PART NO.	零件名称 DESCRIPTION	4S5F	4S5G	4S5H	4S5J	备注 REMARKS
28	95702-06500	螺母 NUT, FLANGE	1	1	1	1	
29	90387-068J2	轴套 COLLAR	1	1	1	1	
30	4S5-E4885-00	弯曲软管 5 HOSE, BEND 5	1	1	1	1	
31	5WG-E3542-10	负压传感软管 1 HOSE, VACUUM SENSING 1	1	1	1	1	
32	90467-08070	卡环 CLIP	2	2	2	2	

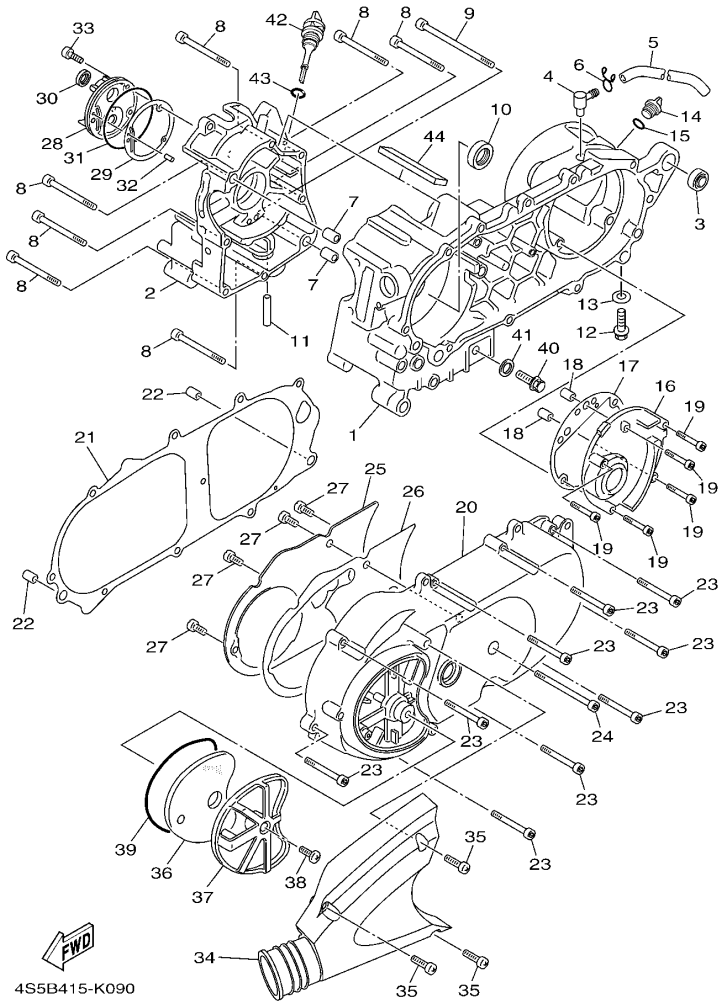

4S5B415-K090

FIG. 9 曲轴箱

CRANKCASE

参照 号码	零件号码 PART NO.	零件名称 DESCRIPTION	4SF	4SG	4SH	4SJ	备注 REMARKS
1	4S5-E5111-00	曲轴箱 1 CRANKCASE 1	1	1	1	1	
2	4S5-E5121-00	曲轴箱 2 CRANKCASE 2	1	1	1	1	
3	4KL-F2216-00	后减震器衬套 BUSH, REAR SHOCK ABSORBER	1	1	1	1	
4	5MH-E5371-00	通气管接头 BREATHER	1	1	1	1	
5	90446-13800	软管 HOSE	1	1	1	1	
6	90467-12802	卡环 CLIP	1	1	1	1	
7	99530-12016	定位销 PIN, DOWEL	2	2	2	2	
8	91312-06060	螺栓 BOLT	7	7	7	7	
9	91312-06100	螺栓 BOLT	1	1	1	1	
10	93102-22817	油封 OIL SEAL	1	1	1	1	
11	1CC-E3416-00	机油管 1 PIPE, OIL 1	1	1	1	1	
12	95812-08016	凸缘螺栓 BOLT, FLANGE	1	1	1	1	
13	90430-08119	衬垫 GASKET	1	1	1	1	
14	4KL-E5363-00	机油塞 PLUG, OIL	1	1	1	1	
15	93210-14104	O型环 O-RING	1	1	1	1	
16	4KL-E5421-00	曲轴箱盖 2 COVER, CRANKCASE 2	1	1	1	1	
17	4KL-E5461-10	曲轴箱盖衬垫 2 GASKET, CRANKCASE COVER 2	1	1	1	1	
18	99530-10114	定位销 PIN, DOWEL	2	2	2	2	
19	91312-06040	螺栓 BOLT	5	5	5	5	
20	5WG-E5411-40	曲轴箱盖 1 COVER, CRANKCASE 1	1	1	1	1	
21	5WG-E5451-10	曲轴箱盖衬垫 1 GASKET, CRANKCASE COVER 1	1	1	1	1	
22	99530-10114	定位销 PIN, DOWEL	2	2	2	2	
23	91312-06035	螺栓 BOLT	9	9	9	9	
24	91312-06060	螺栓 BOLT	1	1	1	1	
25	5WG-E5191-01	面板 PLATE	1	1	1	1	
26	5WG-E5455-00	衬垫 1 GASKET 1	1	1	1	1	
27	98902-06012	十字槽盘头螺钉 SCREW, BIND	4	4	4	4	

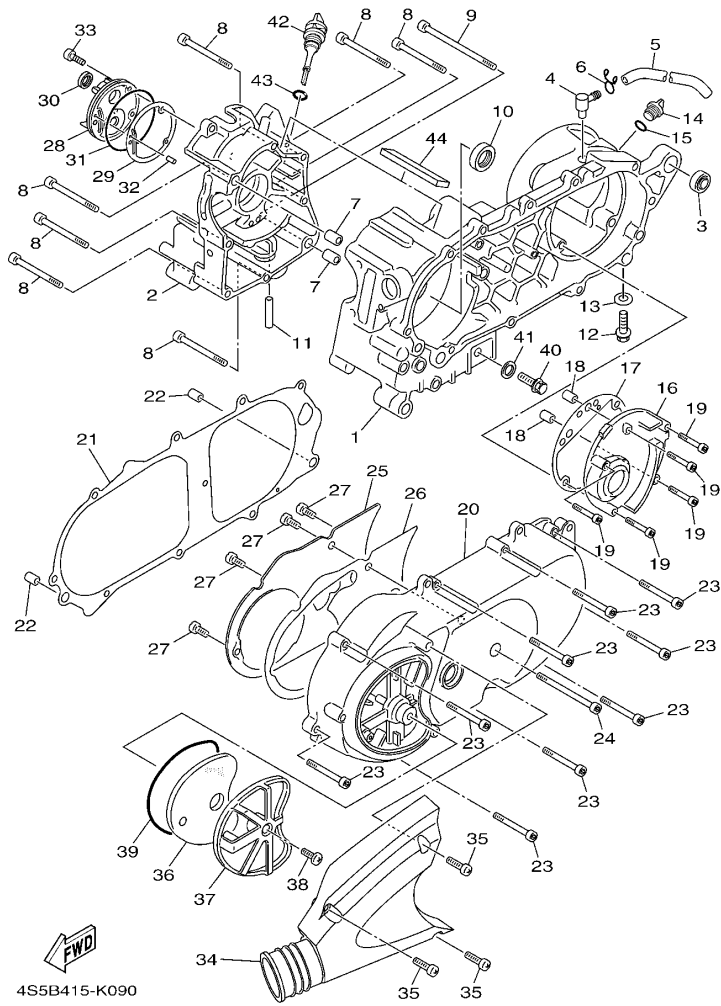

4S5B415-K090

FIG. 9 曲轴箱

CRANKCASE

参照 号码	零件号码 PART NO.	零件名称 DESCRIPTION	4S5F	4S5G	4S5H	4S5J	备注 REMARKS
28	5WG-E5417-01	盖 1 COVER, CAP	1	1	1	1	
29	5WG-E5453-10	化油器盖衬垫 GASKET	1	1	1	1	
30	93102-19808	油封 OIL SEAL	1	1	1	1	
31	93211-028A9	0 型环 O-RING	1	1	1	1	
32	93604-12831	定位销 PIN, DOWEL	1	1	1	1	
33	92012-06020	螺钉 BOLT, BUTTON HEAD	3	3	3	3	
34	5WG-E5471-01	空气导管 DUCT, AIR	1	1	1	1	
35	98902-06020	十字槽盘头螺钉 SCREW, BIND	3	3	3	3	
36	4P7-E5407-00	滤芯 1 ELEMENT 1	1	1	1	1	
37	5WG-E5404-01	滤芯导管 GUIDE, ELEMENT	1	1	1	1	
38	98902-06016	十字槽盘头螺钉 SCREW, BIND	1	1	1	1	
39	5WG-E5472-00	空气导管密封圈 SEAL, AIR DUCT	1	1	1	1	
40	90340-12806	螺塞 PLUG, STRAIGHT SCREW	1	1	1	1	
41	90201-12172	平垫圈 WASHER, PLATE	1	1	1	1	
42	5WG-E5362-02	油标塞 PLUG, OIL LEVEL	1	1	1	1	
43	5WG-E3769-00	0 型环 O-RING	1	1	1	1	
44	4S5-E5789-00	减震器 DAMPER	1	1	1	1	

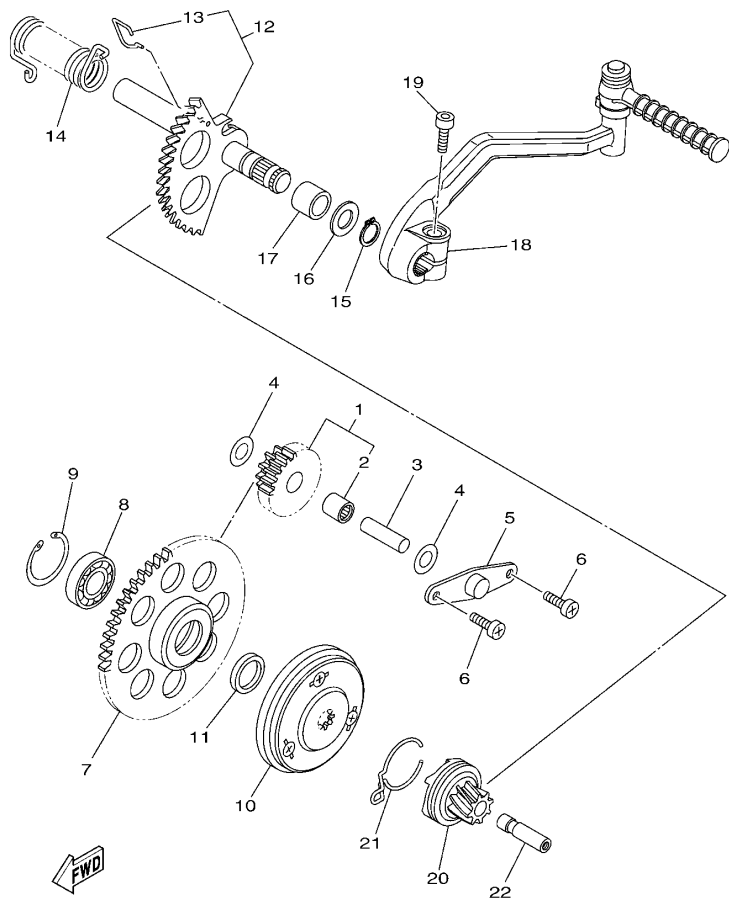

4S5B415-K100

FIG. 10 起动机

STARTER

参照 号码	零件号码 PART NO.	零件名称 DESCRIPTION	4SFE	4SFG	4SHH	4SJ	备注 REMARKS
1	4KL-E5650-10	中间齿轮组合 IDLE GEAR ASSY	1	1	1	1	
2	93317-110Y4	.轴承 .BEARING	1	1	1	1	
3	5WG-E5521-00	轴 1 SHAFT 1	1	1	1	1	
4	90201-108A3	平垫圈 WASHER, PLATE	2	2	2	2	
5	5MH-E5532-00	惰齿轮面板 PLATE, IDLE GEAR	1	1	1	1	
6	98502-06012	十字螺钉 SCREW, PAN HEAD	2	2	2	2	
7	4KL-E5524-00	起动机轮 WHEEL, STARTER	1	1	1	1	
8	93306-003X8	轴承 BEARING	1	1	1	1	
9	99009-35700	卡环 CIRCLIP	1	1	1	1	
10	4KL-E5570-01	起动机离合器组合 STARTER CLUTCH ASSY	1	1	1	1	
11	90201-163G6	平垫圈 WASHER, PLATE	1	1	1	1	
12	4KL-E5601-11	起动机轴组合 KICK SHAFT ASSY	1	1	1	1	
13	4KL-E5687-00	.钢夹 .CLIP	1	1	1	1	
14	90508-40838	扭簧 SPRING, TORSION	1	1	1	1	
15	99009-17400	卡环 CIRCLIP	1	1	1	1	
16	90201-175F6	平垫圈 WASHER, PLATE	1	1	1	1	
17	90380-17234	固体套管 BUSH, SOLID	1	1	1	1	
18	4KL-E5620-01	起动机曲柄组合 KICK CRANK ASSY	1	1	1	1	
19	91312-08030	螺栓 BOLT	1	1	1	1	
20	4KL-E5630-00	起动机小齿轮组合 KICK PINION ASSY	1	1	1	1	
21	5MH-E5673-00	钢夹 CLIP	1	1	1	1	
22	4KL-E5659-00	轴 SHAFT	1	1	1	1	

FIG. 11 离合器

CLUTCH

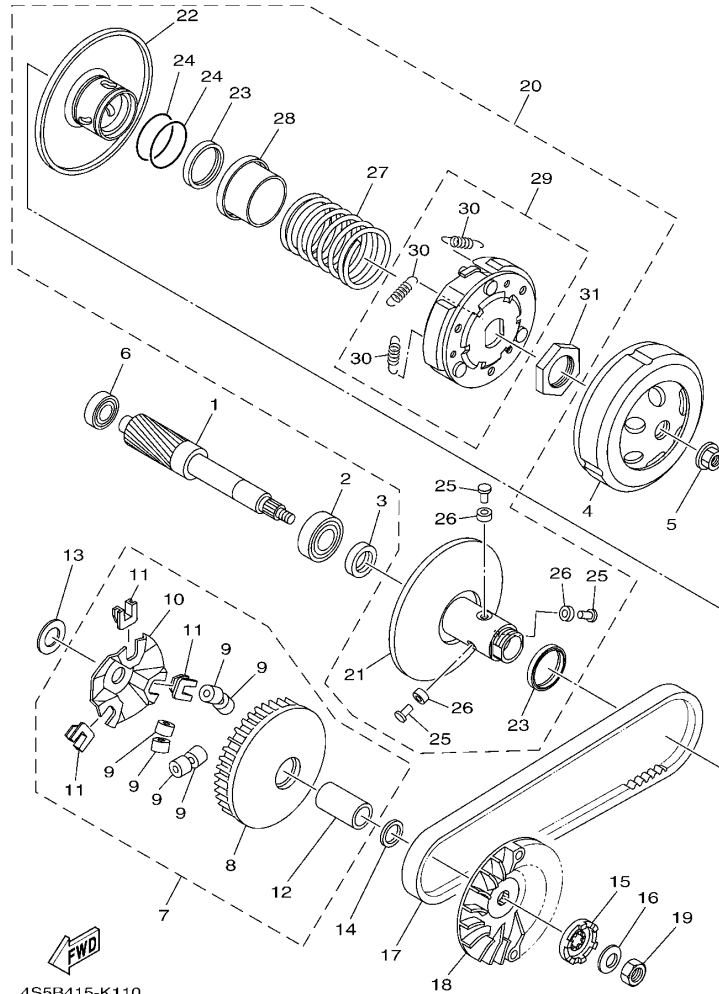

4S5B415-K110

参照 号码	零件号码 PART NO.	零件名称 DESCRIPTION	4S5F	4S5G	4S5H	4S5J	备注 REMARKS
1	4KL-E6111-00	初级驱动齿轮 GEAR, PRIMARY DRIVE	1	1	1	1	
2	93306-204YN	轴承 BEARING	1	1	1	1	
3	93102-22805	油封 OIL SEAL	1	1	1	1	
4	4KL-E6611-20	离合器壳体组合 CLUTCH HOUSING COMP.	1	1	1	1	
5	90179-14805	螺母 NUT	1	1	1	1	
6	93306-203Y0	轴承 BEARING	1	1	1	1	
7	4KL-E7601-21	主槽轮组合 PRIMARY SHEAVE ASSY	1	1	1	1	
8	4KL-E7620-20	主滑轮组合 PRIMARY SLIDING SHEAVE COMP.	1	1	1	1	
9	4KL-E7632-21	重锤 WEIGHT	6	6	6	6	
10	4KL-E7623-20	凸轮 CAM	1	1	1	1	
11	4KL-E7653-20	滑块 SLIDER	3	3	3	3	
12	4KL-E7645-20	安装 COLLAR	1	1	1	1	
13	90201-16809	平垫圈 WASHER, PLATE	1	1	1	1	
14	90201-163J6	平垫圈 WASHER, PLATE	1	1	1	1	
15	4KL-E5657-00	单向离合器 CLUTCH, ONEWAY	1	1	1	1	
16	90208-12050	弹性挡圈 WASHER, CONICAL SPRING	1	1	1	1	
17	4KL-E7641-00	V型皮带 V-BELT	1	1	1	1	
18	4KL-E7611-20	主固定槽 SHEAVE, PRIMARY FIXED	1	1	1	1	
19	90170-12011	螺母 NUT	1	1	1	1	
20	4KL-E7602-22	副槽轮组合 SECONDARY SHEAVE ASSY	1	1	1	1	
21	4KL-E7660-21	副固定槽轮组合 SECONDARY FIXED SHEAVE COMP.	1	1	1	1	
22	4KL-E7670-20	副滑轮 SECONDARY SLIDING SHEAVE	1	1	1	1	
23	4KL-E7465-00	毡密封 SEAL	2	2	2	2	
24	4KL-E7465-20	毡密封 SEAL	2	2	2	2	
25	4KL-E7664-20	导承销 PIN, GUIDE	3	3	3	3	
26	4KL-E7674-20	导向 COLLAR, GUIDE	3	3	3	3	
27	4KL-E7683-20	辅助弹簧 SPRING, SECONDARY	1	1	1	1	

FIG. 11 离合器

CLUTCH

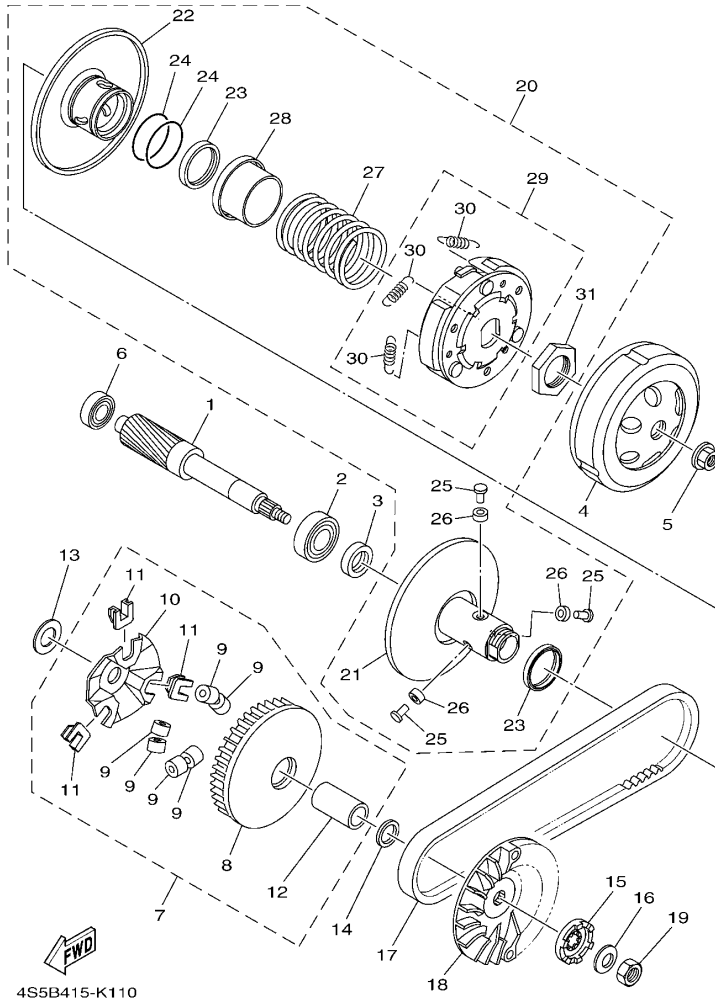

参照 号码	零件号码 PART NO.	零件名称 DESCRIPTION	4SF	4SG	4SH	4SJ	备注 REMARKS
28	4KL-E7684-20	. 辅助弹簧座 .SEAT, SECONDARY SPRING	1	1	1	1	
29	4KL-E6620-20	. 离合器载架组合 .CLUTCH CARRIER ASSY	1	1	1	1	
30	4KL-E6626-20	. 离合器重锤弹簧 1 .SPRING, CLUTCH WEIGHT 1	3	3	3	3	
31	4KL-E7668-21	. 螺母 .NUT	1	1	1	1	

FIG. 12 传动

TRANSMISSION

参照 号码	零件号码 PART NO.	零件名称 DESCRIPTION	4S5F	4S5G	4S5H	4S5J	备注 REMARKS
1	4KL-E7410-10	主轮轴组 MAIN AXLE COMP. (40T)	1	1	1	1	
2	93306-301Y1	轴承 BEARING	1	1	1	1	
3	90201-156F8	平垫圈 WASHER, PLATE(0.8T)	1	1	1	1	
4	93311-315X0	轴承 BEARING	1	1	1	1	
5	5WG-E7420-00	驱动轴组合 DRIVE AXLE ASSY	1	1	1	1	
6	93306-302Y1	轴承 BEARING	1	1	1	1	
7	93306-204Y4	轴承 BEARING	1	1	1	1	
8	93102-26852	油封 OIL SEAL	1	1	1	1	

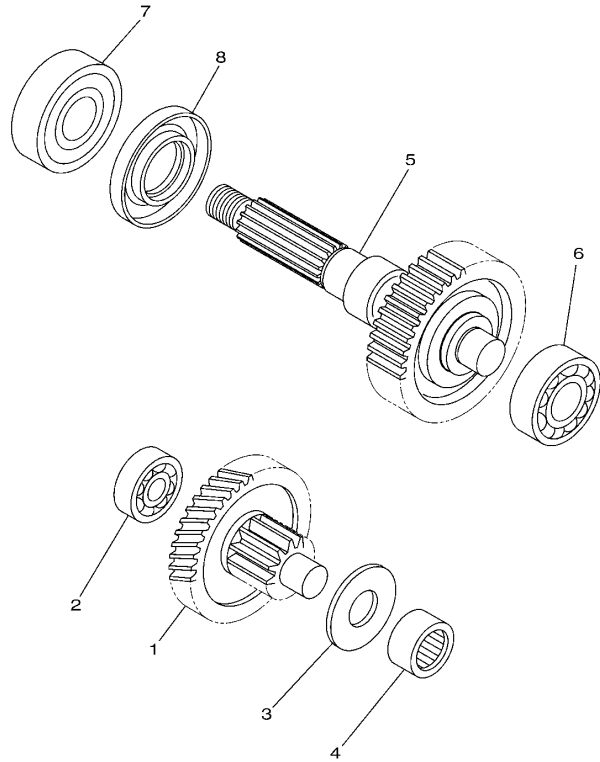

4S5B415-K120

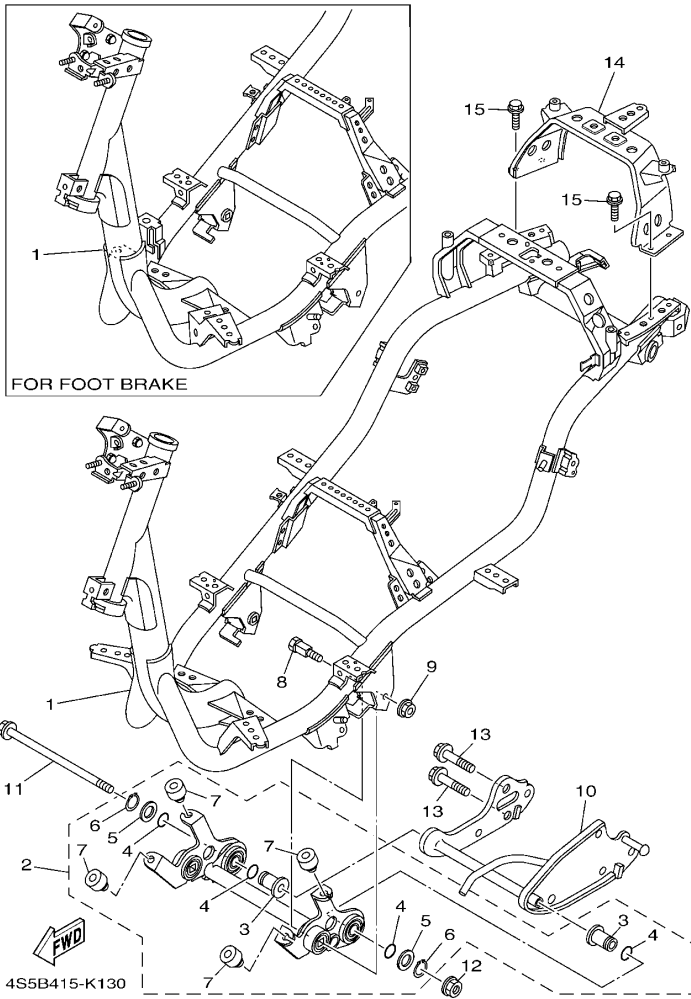

FIG. 13 车架

FRAME

参照 号码	零件号码 PART NO.	零件名称 DESCRIPTION	4SFE	4S5G	4S5H	4S5J	备注 REMARKS
1	4S5-F1110-20	车架组合 FRAME COMP.	1		1		
	4S5-F1110-30	车架组合 FRAME COMP.		1		1	
2	4S5-X2142-00	发动机托架组合 2 ENGINE BRACKET COMP.2	1	1	1	1	
3	5WG-E5317-01	.发动机架衬套 .SPACER, ENGINE MOUNT	2	2	2	2	
4	93210-15639	.O型环 .O-RING	4	4	4	4	
5	90201-17804	.平垫圈 .WASHER, PLATE	2	2	2	2	
6	99009-17400	.卡环 .CIRCLIP	2	2	2	2	
7	5WG-F118W-00	.限位板 .STOPPER	4	4	4	4	
8	5WG-F1481-01	发动机装配螺栓 1 BOLT, ENGINE MOUNTING 1	2	2	2	2	
9	95602-10200	自锁螺母 NUT, U FLANGE	2	2	2	2	
10	5WG-F1410-10	发动机托架组合 ENGINE BRACKET COMP.	1	1	1	1	
11	5WG-F1482-01	发动机装配螺栓 2 BOLT, ENGINE MOUNTING 2	1	1	1	1	
12	95602-10200	自锁螺母 NUT, U FLANGE	1	1	1	1	
13	95812-10030	凸缘螺栓 BOLT, FLANGE	2	2	2	2	
14	4S5-F116F-00	后支承 STAY, REAR	1	1	1	1	
15	95802-06014	凸缘螺栓 BOLT, FLANGE	4	4	4	4	

FIG. 14 挡泥板

FENDER

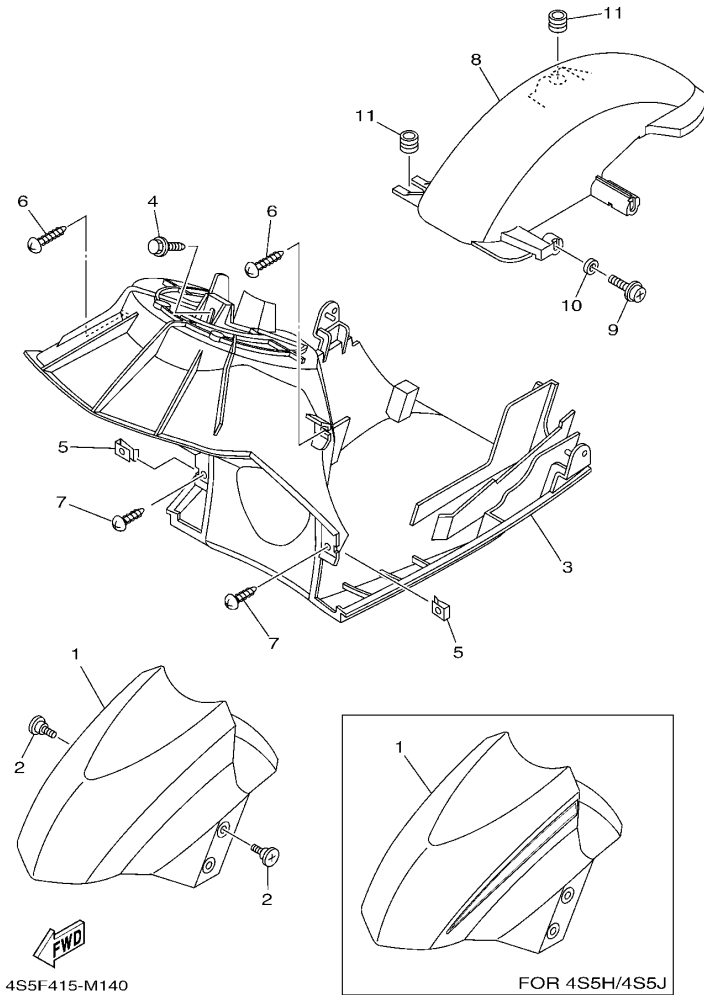

参照 号码	零件号码 PART NO.	零件名称 DESCRIPTION	4SF	4SG	4SH	4SJ	备注 REMARKS
1	4S5-F1511-01-WL	前挡泥板 FENDER, FRONT	1	1			UR 幻银车用 UR FOR STDS
	4S5-F1511-01-AL	前挡泥板 FENDER, FRONT	1	1			UR 黄车用 UR FOR CMY
	4S5-F1511-01-P7	前挡泥板 FENDER, FRONT	1	1			UR 金属蓝车用 UR FOR BMC
	4S5-F1511-01-P3	前挡泥板 FENDER, FRONT	1	1			UR 亮金属红车用 UR FOR VRM5
	4S5-F1511-01-P2	前挡泥板 FENDER, FRONT	1	1			UR 金属黑色车用 UR FOR SMX
	4S5-X2150-H0-P2	前挡泥板 FRONT FENDER ASSY			1	1	UR 金属黑色 无光泽黑车用 UR SMX FOR MBL2
	4S5-X2150-H0-P8	前挡泥板 FRONT FENDER ASSY			1	1	UR 无光泽金属蓝 浅蓝鸡尾白色 1 车用 UR MBM3 FOR BWC1
2	90154-06807	夹紧螺钉 SCREW, BINDING	4	4	4	4	
3	4S5-F1552-00	内防护板 FENDER, INNER	1	1	1	1	
4	90119-068A3	带垫螺栓 BOLT, WITH WASHER	1	1	1	1	
5	90183-05818	弹性螺母 NUT, SPRING	2	2	2	2	
6	97702-50016	自攻螺钉 SCREW, TAPPING	2	2	2	2	
7	97702-50012	自攻螺钉 SCREW, TAPPING	2	2	2	2	
8	5WG-F1611-00	后挡泥板 FENDER, REAR	1	1	1	1	
9	90159-06867	带垫螺钉 SCREW, WITH WASHER	1	1	1	1	
10	90387-063F7	轴套 COLLAR	1	1	1	1	
11	90480-12803	橡胶垫 GROMMET	2	2	2	2	

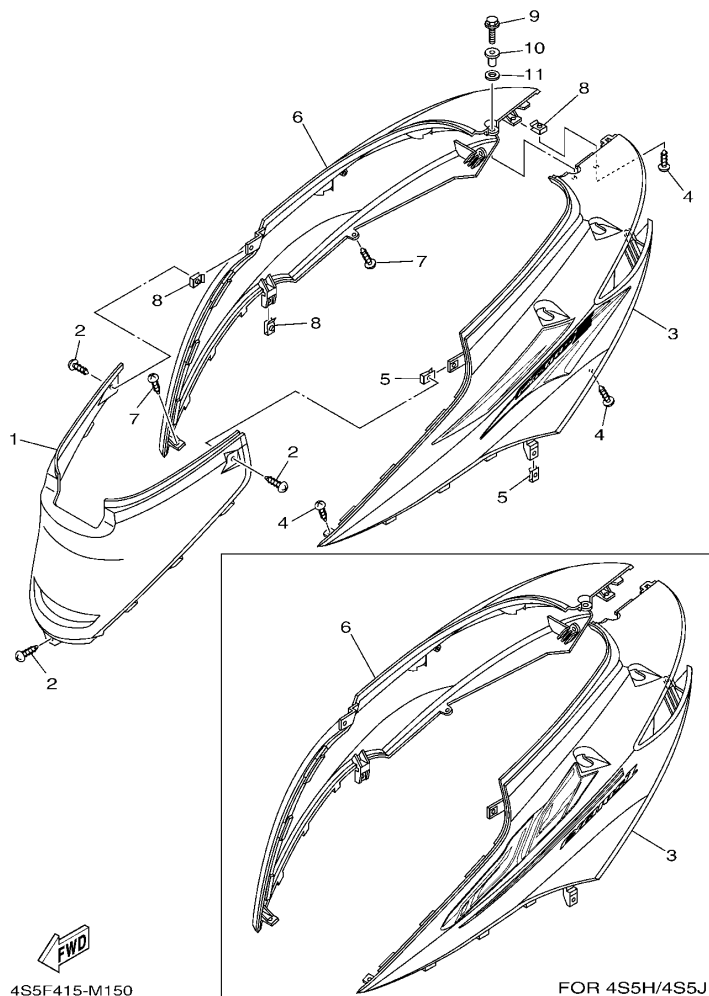

FIG. 15 侧盖

SIDE COVER

参照 号码	零件号码 PART NO.	零件名称 DESCRIPTION	4SF	4SG	4SH	4SJ	备注 REMARKS
1	4S5-F1711-00-P2	侧盖 1 COVER, SIDE 1	1	1	1	1	金属黑色 SMX
	4S5-F1711-00-P7	侧盖 1 COVER, SIDE 1			1	1	无光泽金属蓝 MBM3
2	97702-50012	自攻螺钉 SCREW, TAPPING	3	3	3	3	
	4S5-X2172-F0-WL	侧盖 2 COVER, SIDE 2	1	1			UR 幻银车用 UR FOR STDS
3	4S5-X2172-F0-AL	侧盖 2 COVER, SIDE 2	1	1			UR 黄车用 UR FOR CMY
	4S5-X2172-F0-P7	侧盖 2 COVER, SIDE 2	1	1			UR 金属蓝车用 UR FOR BMC
4	4S5-X2172-F0-P3	侧盖 2 COVER, SIDE 2	1	1			UR 亮金属红车用 UR FOR VRM5
	4S5-X2172-F0-P2	侧盖 2 COVER, SIDE 2	1	1			UR 金属黑色车用 UR FOR SMX
4S5-X2172-H0-P8	侧盖 2 COVER, SIDE 2				1	1	UR 无光泽黑车用 UR FOR MBL2
	4S5-X2172-H0-P9	侧盖 2 COVER, SIDE 2			1	1	UR 浅蓝鸡尾白色 1 车用 UR FOR BWC1
4	97702-50012	自攻螺钉 SCREW, TAPPING	3	3	3	3	
5	90183-05818	弹性螺母 NUT, SPRING	2	2	2	2	
6	4S5-X2173-F0-WL	侧盖 3 COVER, SIDE 3	1	1			UR 幻银车用 UR FOR STDS
	4S5-X2173-F0-AL	侧盖 3 COVER, SIDE 3	1	1			UR 黄车用 UR FOR CMY
4S5-X2173-F0-P7	侧盖 3 COVER, SIDE 3		1	1			UR 金属蓝车用 UR FOR BMC
	4S5-X2173-F0-P3	侧盖 3 COVER, SIDE 3	1	1			UR 亮金属红车用 UR FOR VRM5
4S5-X2173-F0-P2	侧盖 3 COVER, SIDE 3		1	1			UR 金属黑色车用 UR FOR SMX
	4S5-X2173-H0-P8	侧盖 3 COVER, SIDE 3			1	1	UR 无光泽黑车用 UR FOR MBL2
4S5-X2173-H0-P9	侧盖 3 COVER, SIDE 3				1	1	UR 浅蓝鸡尾白色 1 车用 UR FOR BWC1
	7	97702-50012	自攻螺钉 SCREW, TAPPING	2	2	2	2
8	90183-05818	弹性螺母 NUT, SPRING	3	3	3	3	
9	95802-06020	凸缘螺栓 BOLT, FLANGE	1	1	1	1	
10	90387-068H6	轴套 COLLAR	1	1	1	1	
11	4S5-F1773-00	固定套 GROMMET	1	1	1	1	

FIG. 16 后悬挂

REAR SUSPENSION

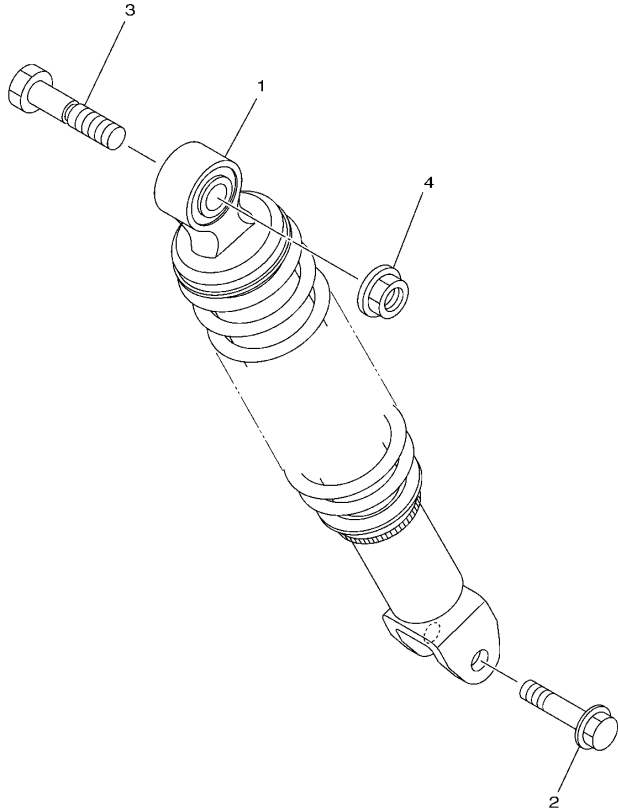

参照 号码	零件号码 PART NO.	零件名称 DESCRIPTION	4SFE	4SFG	4SGH	4SJJ	备注 REMARKS
1	4S5-F2210-10	后减震器组合 SHOCK ABSORBER ASSY, REAR	1	1			
	4S5-F2210-00	后减震器组合 SHOCK ABSORBER ASSY, REAR			1	1	
2	90105-08861	凸缘螺栓 BOLT, FLANGE	1	1	1	1	
3	90101-10809	螺栓 BOLT	1	1	1	1	
4	95702-10500	螺母 NUT, FLANGE	1	1	1	1	



1CC1415-K160

FIG. 17 前叉

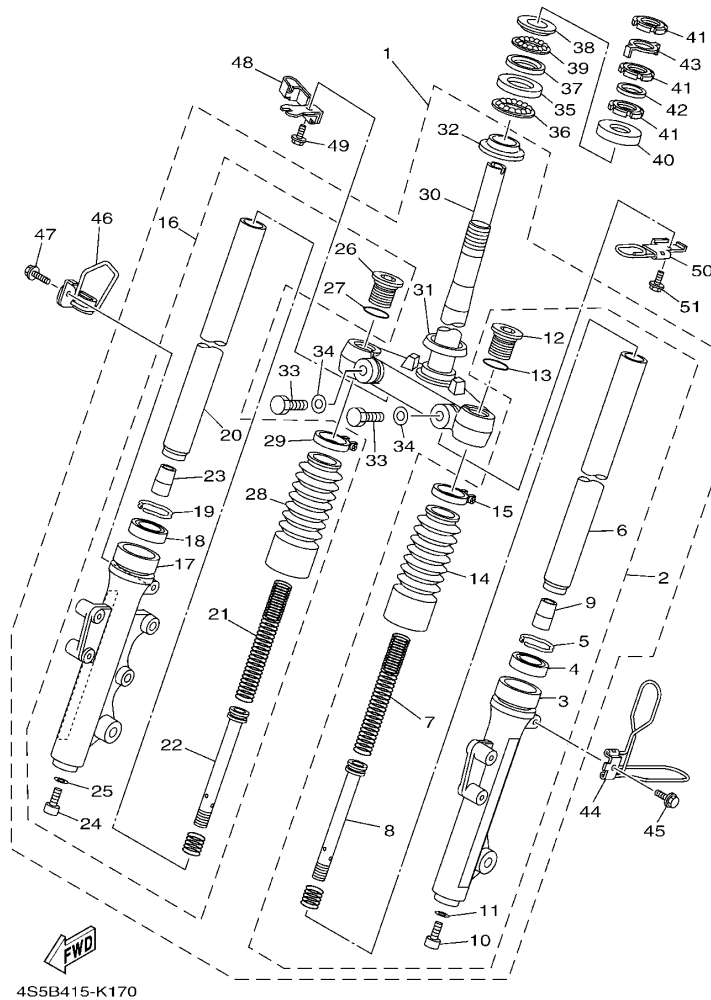
FRONT FORK

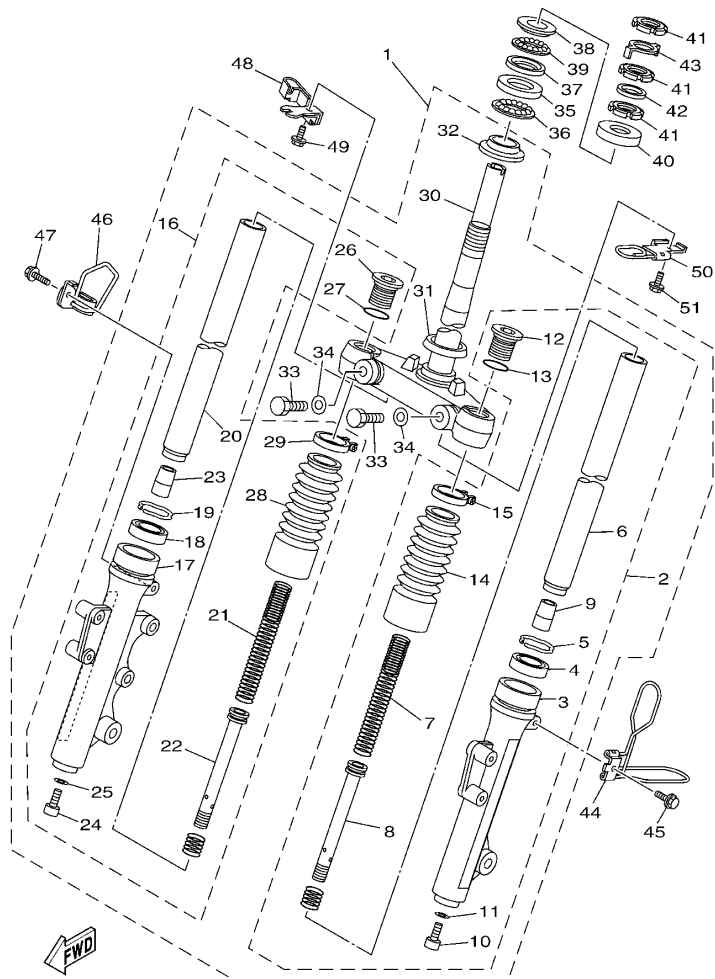

参照 号码	零件号码 PART NO.	零件名称 DESCRIPTION	4S5F	4S5G	4S5H	4S5J	备注 REMARKS
1	4S5-X2310-03	前叉总成 FRONT FORK ASSY	1	1	1	1	
2	4S5-X3102-03	.前叉组合(左边) .FRONT FORK ASSY (L.H)	1	1	1	1	
3	4S5-X3126-00	.外管 1 .TUBE, OUTER (LEFT)	1	1	1	1	
4	4GU-F3145-00	.油封 .OIL SEAL	1	1	1	1	
5	5AP-F3153-00	.扣环 .RING, SNAP	1	1	1	1	
6	5WG-F3110-00	.内管组件 1 .INNER TUBE COMP.1	1	1	1	1	
7	4S5-F3141-00	.前叉弹簧 .SPRING, FRONT FORK	1	1	1	1	
8	5WG-F3170-00	.柄管缸套 .CYL.COMP.	1	1	1	1	
9	2D0-F3166-00	.机油锁紧衬套 .SPACER, OIL LOCK	1	1	1	1	
10	5LK-F3356-00	.螺栓 2 .BOLT 2	1	1	1	1	
11	4TU-F3479-00	.衬垫 .GASKET	1	1	1	1	
12	4KL-F3111-00	.顶盖螺栓 .BOLT, CAP	1	1	1	1	
13	5AP-F3147-00	.O型环 .O-RING	1	1	1	1	
14	4KL-F3191-10	.保护罩 .BOOT	1	1	1	1	
15	4KL-F3192-10	.带箍 .BAND	1	1	1	1	
16	4S5-X3103-03	.前叉组合(右边) .FRONT FORK ASSY(R.H)	1	1	1	1	
17	4S5-X3136-00	.外管 2 .TUBE, OUTER (RIGHT)	1	1	1	1	
18	4GU-F3145-00	.油封 .OIL SEAL	1	1	1	1	
19	5AP-F3153-00	.扣环 .RING, SNAP	1	1	1	1	
20	5WG-F3110-00	.内管组件 1 .INNER TUBE COMP.1	1	1	1	1	
21	4S5-F3141-00	.前叉弹簧 .SPRING, FRONT FORK	1	1	1	1	
22	5WG-F3170-00	.柄管缸套 .CYL.COMP.	1	1	1	1	
23	2D0-F3166-00	.机油锁紧衬套 .SPACER, OIL LOCK	1	1	1	1	
24	5LK-F3356-00	.螺栓 2 .BOLT 2	1	1	1	1	
25	4TU-F3479-00	.衬垫 .GASKET	1	1	1	1	
26	4KL-F3111-00	.顶盖螺栓 .BOLT, CAP	1	1	1	1	
27	5AP-F3147-00	.O型环 .O-RING	1	1	1	1	



4S5B415-K170

FIG. 17 前叉

FRONT FORK

参照 号码	零件号码 PART NO.	零件名称 DESCRIPTION	4SFE	4S5G	4S5H	4S5J	备注 REMARKS
28	4KL-F3191-10	. 保护罩 .BOOT	1	1	1	1	
29	4KL-F3192-10	. 带箍 .BAND	1	1	1	1	
30	4S5-F3340-01	. 底托架组 .UNDER BRACKET COMP.	1	1	1	1	
31	4TU-F3144-00	. 防尘罩 .SEAL, DUST	1	1	1	1	
32	4TU-F3411-00	. 滚珠座圈 1 .RACE, BALL 1	1	1	1	1	
33	4RT-F3346-00	. 螺栓 1 .BOLT 1	2	2	2	2	
34	4P7-F3843-00	. 平垫圈 .WASHER, PLAIN	2	2	2	2	
35	4KL-F3412-00	. 滚珠座圈 2 RACE, BALL 2	1	1	1	1	
36	5WG-F341E-00	. 保持架 RETAINER, BALL BEARING	1	1	1	1	
37	4KL-F3412-10	. 滚珠座圈 2 RACE, BALL 2	1	1	1	1	
38	4KL-F3411-00	. 滚珠座圈 1 RACE, BALL 1	1	1	1	1	
39	5WG-F341E-10	. 保持架 RETAINER, BALL BEARING	1	1	1	1	
40	5MH-F3416-01	. 滚珠座圈盖 2 COVER, BALL RACE 2	1	1	1	1	
41	90179-25810	. 螺母 NUT	3	3	3	3	
42	90202-26142	. 平垫圈 WASHER, PLATE	1	1	1	1	
43	5WG-F3418-01	. 专用垫圈 WASHER, SPECIAL	1	1	1	1	
44	1CC-F3317-10	. 钢索支架 HOLDER, CABLE	1	1	1	1	
45	95802-06012	. 凸缘螺栓 BOLT, FLANGE	1	1	1	1	
46	4S5-F5875-01	. 制动软管支架 1 HOLDER, BRAKE HOSE 1	1	1	1	1	
47	95802-06012	. 凸缘螺栓 BOLT, FLANGE	1	1	1	1	
48	52P-F5887-00	. 制动软管支架 HOLDER, BRAKE HOSE	1	1	1	1	
49	95802-06012	. 凸缘螺栓 BOLT, FLANGE	1	1	1	1	
50	4S5-F331E-01	. 钢索导承 GUIDE, CABLE	1	1	1	1	
51	95802-06012	. 凸缘螺栓 BOLT, FLANGE	1	1	1	1	

FIG. 18 油箱

FUEL TANK

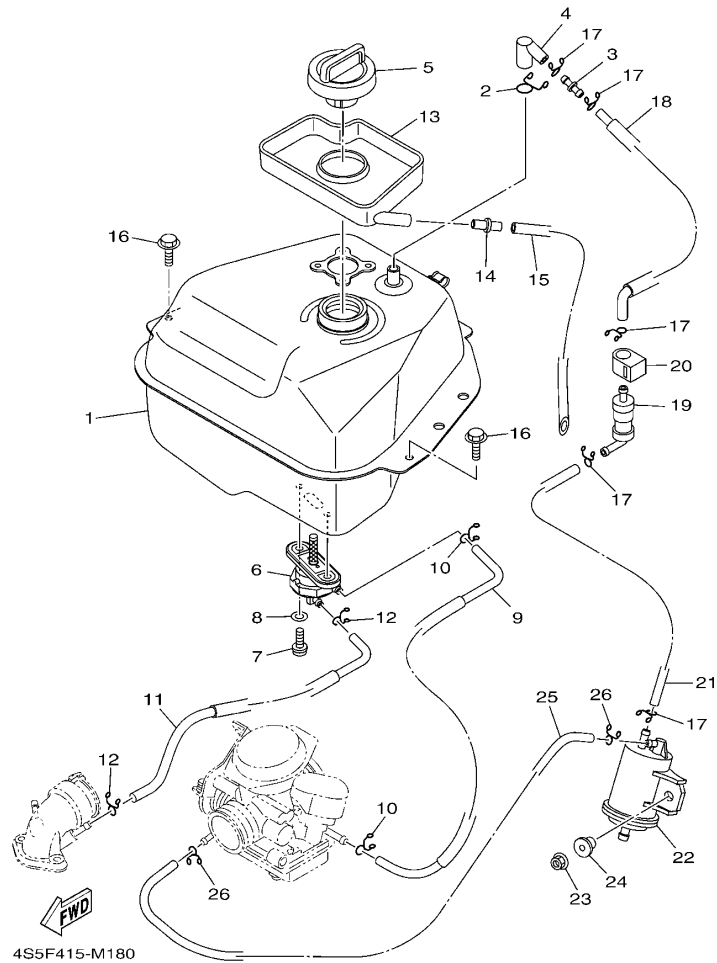

参照 号码	零件号码 PART NO.	零件名称 DESCRIPTION	4SF	4SG	4SH	4SJ	备注 REMARKS
1	4S5-F4110-10	油箱组合 FUEL TANK COMP.	1	1	1	1	
2	90467-12802	卡环 CLIP	1	1	1	1	
3	4S0-F1753-00	连接器轴节 BOSS, CONNECTOR	1	1	1	1	
4	4S0-F4112-00	管 PIPE	1	1	1	1	
5	4S0-F4610-01	油箱盖总成 CAP ASSY	1	1	1	1	
6	5WG-F4500-01	燃油开关组合 1 FUEL COCK ASSY 1	1	1	1	1	
7	90149-06108	螺钉 SCREW	2	2	2	2	
8	90202-05193	平垫圈 WASHER, PLATE	2	2	2	2	
9	4S5-F4311-10	燃油管 1 PIPE, FUEL 1	1	1	1	1	
10	90467-09006	卡环 CLIP	2	2	2	2	
11	4S5-F4312-00	管 2 PIPE 2	1	1	1	1	
12	90467-08003	卡环 CLIP	2	2	2	2	
13	5WG-F414A-00	加油器盖 COVER, FILLER	1	1	1	1	
14	5WY-F1753-00	连接器轴节 BOSS, CONNECTOR	1	1	1	1	
15	91A11-07048	软管 TUBE,FLEXUBLE	1	1	1	1	
16	95802-06014	凸缘螺栓 BOLT, FLANGE	2	2	2	2	
17	90467-09006	卡环 CLIP	5	5	5	5	
18	4S5-F4313-00	管 3 PIPE 3	1	1	1	1	
19	18C-F4180-00	滚动阀组合 ROLL OVER VALVE ASSY	1	1	1	1	
20	4S0-F4135-00	夹箍 1 CLAMP 1	1	1	1	1	
21	4S0-F4314-00	管 4 PIPE 4	1	1	1	1	
22	1CC-F4170-00	过滤缸总成 CANISTER ASSY	1	1	1	1	
23	95702-06500	螺母 NUT, FLANGE	1	1	1	1	
24	90387-068J2	轴套 COLLAR	1	1	1	1	
25	4S5-F4315-00	管 5 PIPE 5	1	1	1	1	
26	90467-08003	卡环 CLIP	2	2	2	2	

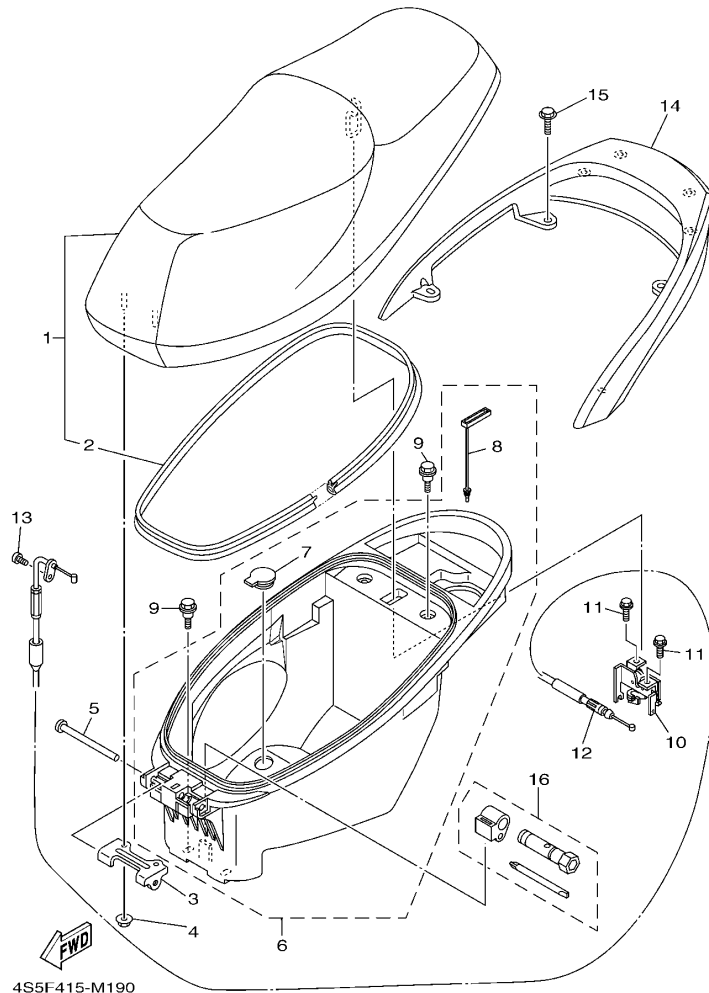

FIG. 19 座位

SEAT

参照 号码	零件号码 PART NO.	零件名称 DESCRIPTION	4SFE	4SFG	4SHH	4SJ	备注 REMARKS
1	4S5-F4730-01	双人座垫组合 DOUBLE SEAT ASSY	1	1			
	4S5-F4730-12	双人座垫组合 DOUBLE SEAT ASSY			1	1	
2	4S5-F475M-01	.密封圈 .SEAL	1	1	1	1	
3	5WG-F4726-00	座位铰 HINGE, SEAT	1	1	1	1	
4	95702-06500	螺母 NUT, FLANGE	2	2	2	2	
5	90241-10801	销 PIN	1	1	1	1	
6	4S5-X247R-00	载物箱组合 BOX,1 ASSY	1	1	1	1	
7	5WY-F4742-00	.塞 .GROMMET	1	1	1	1	
8	5WY-F4633-00	.滚珠链 .CHAIN, BALL	1	1	1	1	
9	90109-06822	螺栓 BOLT	4	4	4	4	
10	4S5-F4780-01	座位锁装置组合 SEAT LOCK ASSY	1	1	1	1	
11	95802-06010	凸缘螺栓 BOLT, FLANGE	2	2	2	2	
12	4S5-F478E-01	车座锁钢索 CABLE, SEAT LOCK	1	1	1	1	
13	98502-05012	十字螺钉 SCREW, PAN HEAD	1	1	1	1	
14	4S5-F4812-10-98	后载架 HANDLE	1	1			黑色 LGB
	4S5-F4812-10-P0	后载架 HANDLE			1	1	无光泽浅灰金属黄 MNYM1
	4S5-F4812-10-P3	后载架 HANDLE			1	1	无光泽金属蓝 MBM3
15	90119-08864	带垫螺栓 BOLT, WITH WASHER	4	4	4	4	
16	4KL-F8100-01	随车工具 TOOL KIT	1	1	1	1	

FIG. 20 前轮

FRONT WHEEL

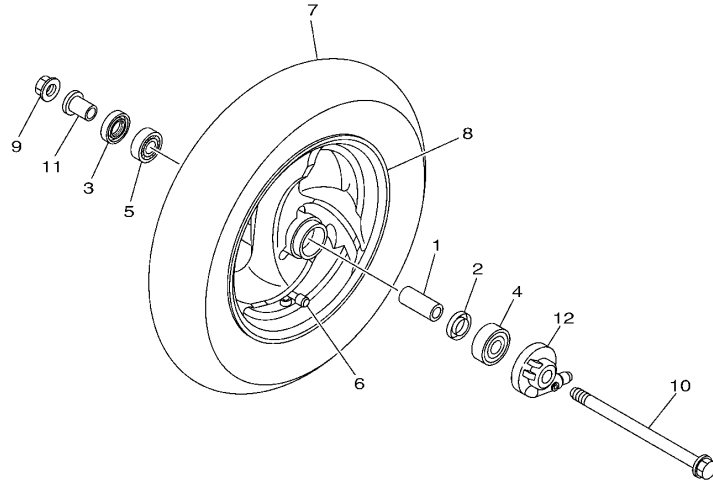

参照 号码	零件号码 PART NO.	零件名称 DESCRIPTION	4SFE	4SFG	4SHH	4SJ	备注 REMARKS
1	90387-12825	轴套 COLLAR	1	1	1	1	
2	5WG-F5315-00	凸缘衬套 FLANGE, SPACER	1	1	1	1	
3	93306-301XJ	轴承 BEARING	1	1	1	1	
4	93306-201X4	轴承 BEARING	1	1	1	1	
5	93900-00827	气门嘴 VALVE, RIM	1	1	1	1	
6	94135-10803	轮胎 (3.50-10) TIRE (3.50-18 4PR)	1	1	1	1	
7	4S5-F5168-01-33	前压铸轮 CAST WHEEL, FRONT	1	1	1	1	CHENG SHIN 雅马哈黑色 YB
8	93106-17806	油封 OIL SEAL	1	1	1	1	
9	95602-12200	自锁螺母 NUT, SELF-LOCKING	1	1	1	1	
10	5WG-F5181-11	前轮轮轴 AXLE, WHEEL	1	1	1	1	
11	90387-125J1	轴套 COLLAR	1	1	1	1	
12	4S5-F5190-11	齿轮装置组合 GEAR UNIT ASSY	1	1	1	1	

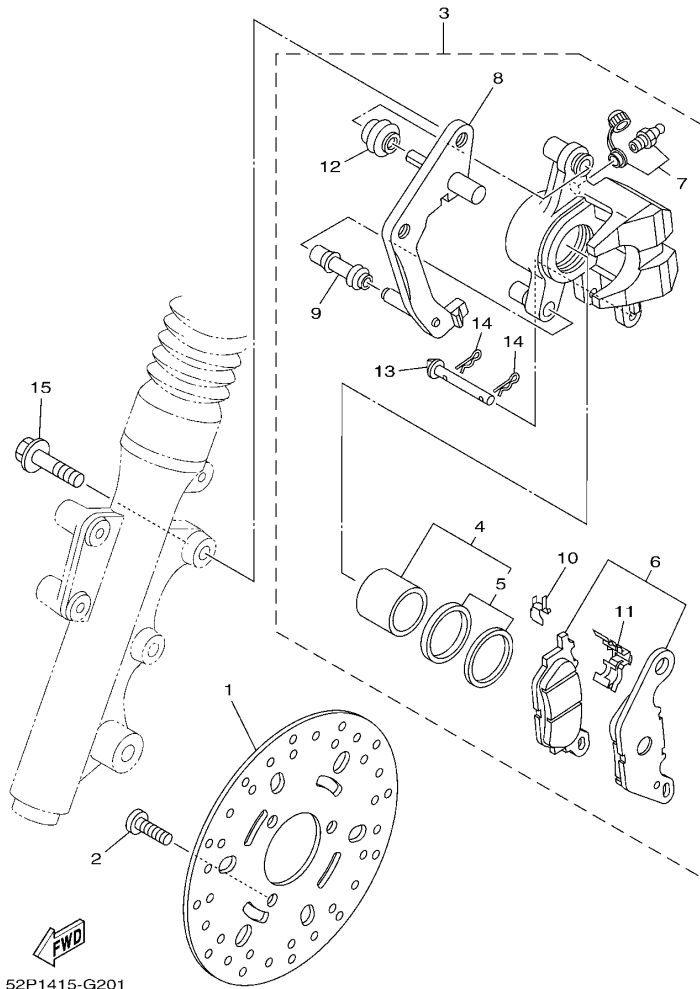

FIG. 21 前制动器卡钳

FRONT BRAKE CALIPER

参照 号码	零件号码 PART NO.	零件名称 DESCRIPTION	4SF	4SG	4SH	4SJ	备注 REMARKS
1	5WG-F582U-40	制动盘 (右边) DISK, BRAKE (RIGHT)	1	1	1	1	
2	90149-08814	螺钉 SCREW	3	3	3	3	
3	3D9-F580U-01 4S5-F580U-01	制动器卡钳组合 (右边) CALIPER ASSY (RIGHT) 制动器卡钳组合 (右边) CALIPER ASSY (RIGHT)	1	1			
4	4S5-W0057-00	卡钳活塞组合 .PISTON ASSY, CALIPER	1	1	1	1	
5	4S5-W0047-00	卡钳密封套件 .CALIPER SEAL KIT	1	1	1	1	
6	4S5-W0045-00	刹车片组合 .BRAKE PAD KIT	1	1	1	1	
7	4S5-W0048-01	带孔螺钉套件 .BLEED SCREW KIT	1	1	1	1	
8	4S5-F5921-01	支承托架 .BRACKET, SUPPORT	1	1	1	1	
9	4S5-F5937-00	保护罩 2 .BOOT 2	1	1	1	1	
10	4S5-F5939-00	扣片 .CLIP, PAD	1	1	1	1	
11	4S5-F5919-00	衬垫支承 .SUPPORT, PAD	1	1	1	1	
12	4S5-F5917-00	卡钳套 .BOOT, CALIPER	1	1	1	1	
13	4S5-F5924-01	刹车片销 .PIN, PAD	1	1	1	1	
14	4S5-F5925-00	卡环 .CLIP	2	2	2	2	
15	95022-10030	凸缘螺栓 BOLT, FLANGE	2	2	2	2	

FIG. 22 后轮

REAR WHEEL

参照 号码	零件号码 PART NO.	零件名称 DESCRIPTION	4SF6	4SG6	4SH6	4SJ6	备注 REMARKS
1	4KL-F5338-10-33	后压铸轮 CAST WHEEL, REAR	1	1	1	1	雅马哈黑色 YB
2	93900-00827	气门嘴 VALVE, RIM	1	1	1	1	
3	94135-10804	轮胎 (3.50-10) TIRE(3.50-10 S6007 51J TL)	1	1	1	1	CHENG SHIN
4	90185-14807	自锁螺母 NUT, SELF-LOCKING	1	1	1	1	
5	90201-20276	平垫圈 WASHER, PLATE (T=1.0)	1	1	1	1	
6	5WG-X2534-00	制动蹄块组合 BRAKE SHOE SET	1	1	1	1	
7	90506-12001	.拉簧 .SPRING, TENSION	1	1	1	1	
8	90506-15001	.拉簧 .SPRING, TENSION	1	1	1	1	
9	5MH-F5351-01	凸轮轴 CAMSHAFT	1	1	1	1	
10	93210-108J3	O型环 O-RING	2	2	2	2	
11	4KL-F533A-01	指示片 PLATE, INDICATOR	1	1	1	1	
12	4KL-F5355-01	制动臂 LEVER, CAMSHAFT	1	1	1	1	
13	90101-06046	螺栓 BOLT	1	1	1	1	
14	5WG-F5326-01	枢轴 PIN, PIVOT	1	1	1	1	
15	95702-10500	螺母 NUT, FLANGE	1	1	1	1	
16	93210-07890	O型环 O-RING	1	1	1	1	

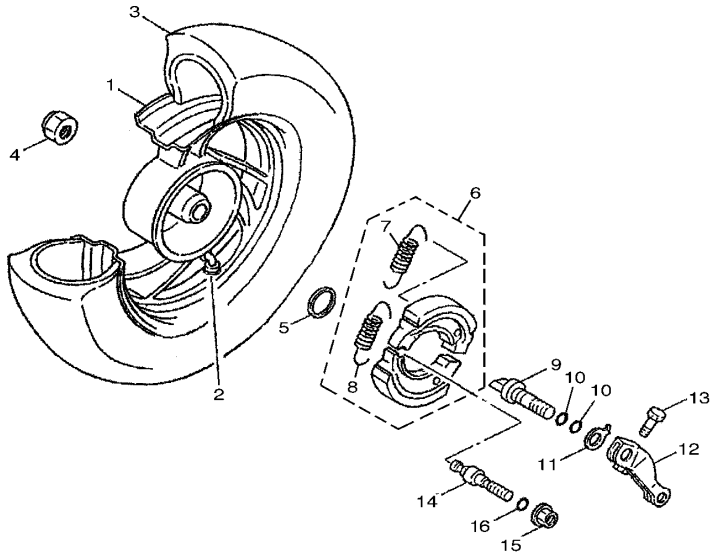

3D31210-D211

FIG. 23 操纵手柄·钢索

STEERING HANDLE & CABLE

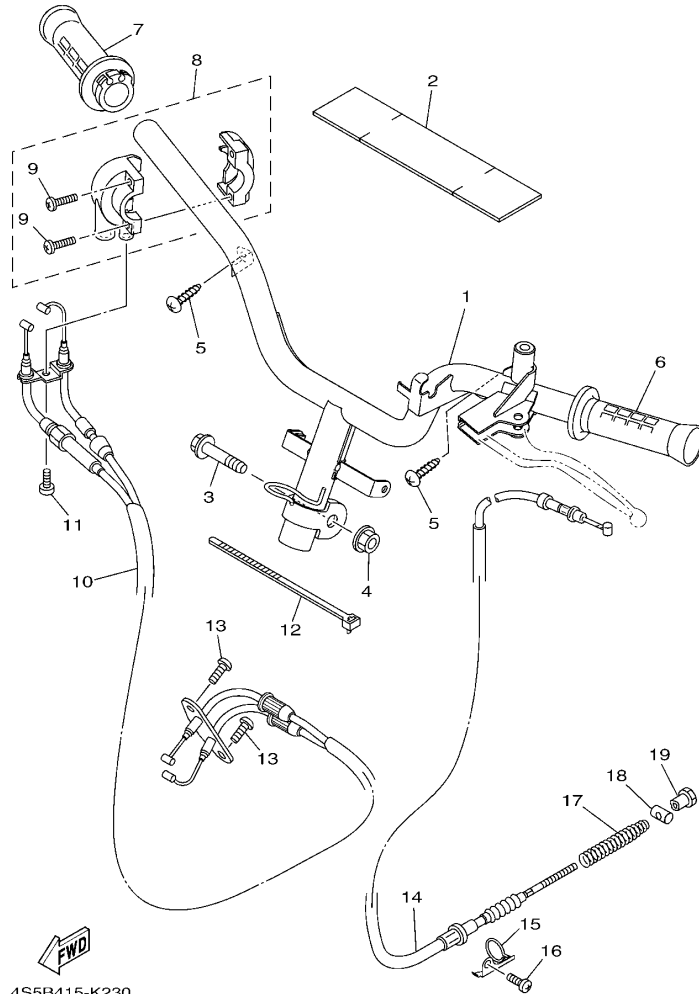

4S5B415-K230

参照 号码	零件号码 PART NO.	零件名称 DESCRIPTION	4SF	4SG	4SH	4SJ	备注 REMARKS
1	4S5-F6110-30	手柄组件 HANDLE COMP.	1		1		
	4S5-F6110-50	手柄组件 HANDLE COMP.		1		1	
2	5WG-F6113-00	减震垫 DAMPER	1	1	1	1	
3	90105-10839	凸缘螺栓 BOLT, FLANGE	1	1	1	1	
4	95602-10200	自锁螺母 NUT, U FLANGE	1	1	1	1	
5	97702-50016	自攻螺钉 SCREW, TAPPING	2	2	2	2	
6	4KL-F6241-20	握把 (左边) GRIP	1	1	1	1	
7	4S0-F6240-00	握把 (右边) GRIP ASSY	1	1	1	1	
8	4P7-F6270-10	钢索连接器盖组合 CAP GRIP ASSY	1	1	1	1	
9	98507-05020	十字螺钉 SCREW, PAN HEAD	2	2	2	2	
10	4S5-F6301-00	油门钢索组合 THROTTLE CABLE ASSY	1	1	1	1	
11	98502-05010	十字螺钉 SCREW, PAN HEAD	1	1	1	1	
12	90464-20809	线夹 CLAMP	1	1	1	1	
13	92012-05010	螺钉 BOLT, BUTTON HEAD	2	2	2	2	
14	4S5-F6351-01	制动器钢索 CABLE, BRAKE	1		1		
15	4KL-F637G-01	钢索支架 HOLDER, WIRE	1	1	1	1	
16	98502-06012	十字螺钉 SCREW, PAN HEAD	1	1	1	1	
17	90501-16831	压簧 SPRING, COMPRESSION	1	1	1	1	
18	90249-12806	销 PIN	1	1	1	1	
19	90179-06843	螺母 NUT	1	1	1	1	

FIG. 24 前主缸

FRONT MASTER CYLINDER

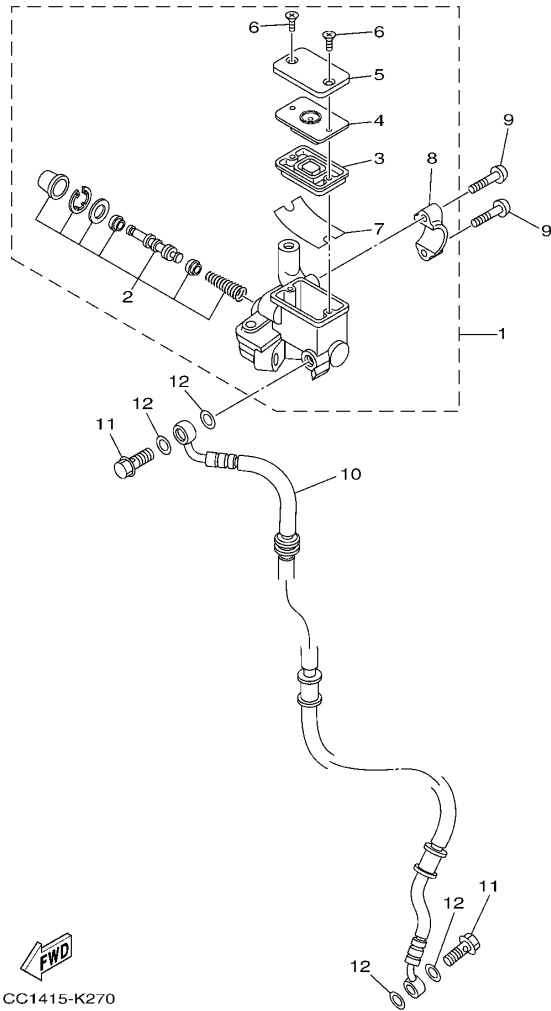

参照 号码	零件号码 PART NO.	零件名称 DESCRIPTION	4SF6	4S6G	4S6H	4S6J	备注 REMARKS
1	4KL-F5870-21	主缸副组合 MASTER CYLINDER SUB ASSY	1	1	1	1	
2	3D9-W0041-02	.前主缸套件 .CYLINDER KIT, MASTER	1	1	1	1	
3	4KL-F5854-00	.油箱隔膜 .DIAPHRAGM, RESERVOIR	1	1	1	1	
4	4KL-F585B-00	.隔板 .PLATE, DIAPHRAGM	1	1	1	1	
5	4KL-F5852-00	.储油箱盖 .CAP, RESERVOIR	1	1	1	1	
6	4KL-F589H-01	.螺钉 .SCREW	2	2	2	2	
7	4KL-F5896-00	.储油箱面板 .PLATE, RESERVOIR	1	1	1	1	
8	4KL-F5867-00	.主缸托架 .BRACKET, MASTER CYLINDER	1	1	1	1	
9	92012-06025	螺钉 BOLT, BUTTON HEAD	2	2	2	2	
10	4S5-F5872-02	制动软管 1 HOSE, BRAKE 1	1	1	1	1	
11	90401-10823	螺栓 BOLT, UNION	2	2	2	2	
12	90201-108J9	平垫圈 WASHER, PLATE	4	4	4	4	

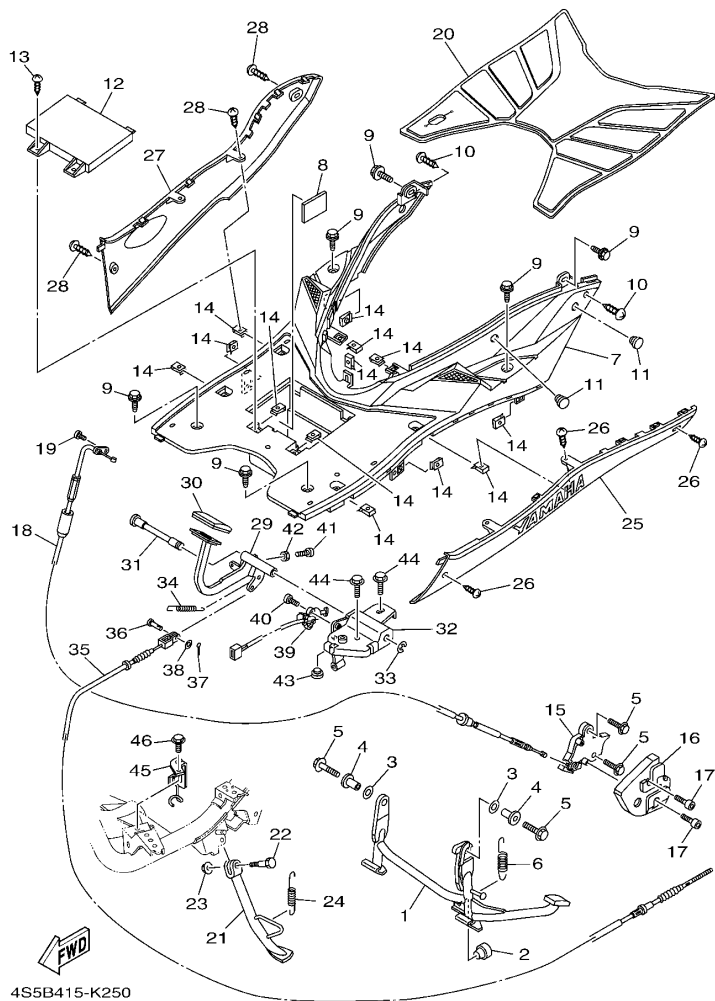

4S5B415-K250

FIG. 25 搁脚·支架

STAND & FOOTREST

参照 号码	零件号码 PART NO.	零件名称 DESCRIPTION	4SFE	4SSG	4SHH	4S5J	备注 REMARKS
1	4S5-F7111-00	主支承 STAND, MAIN	1	1	1	1	
2	4KL-F7314-00	限位板 STOPPER	1	1	1	1	
3	90202-15804	平垫圈 WASHER, PLATE	2	2	2	2	
4	5WG-F7113-01	主支承安装 COLLAR, MAIN STAND	2	2	2	2	
5	95812-10035	凸缘螺栓 BOLT, FLANGE	4	4	4	4	
6	90506-35820	拉簧 SPRING, TENSION	1	1	1	1	
7	4S5-F7481-01	搁脚踏板 BOARD, FOOTREST	1	1	1	1	
8	4S5-H2121-00	蓄电池垫 PAD, BATTERY	1	1	1	1	
9	90119-06157	带垫螺栓 BOLT, WITH WASHER	6	6	6	6	
10	97702-50012	自攻螺钉 SCREW, TAPPING	2	2	2	2	
11	5WG-F6199-00	绝缘插头 PLUG, BLIND	2	2	2	2	
12	4S5-H2129-00	蓄电池盖 COVER, BATTERY	1	1	1	1	
13	97702-50012	自攻螺钉 SCREW, TAPPING	2	2	2	2	
14	90183-05818	弹性螺母 NUT, SPRING	13	13	13	13	
15	5WG-F7180-01	锁紧装置组合 LOCK ASSY	1	1	1	1	
16	5WG-F7151-01	主支承托架 BRACKET, MAIN STAND	1	1	1	1	
17	90149-06827	螺钉 SCREW	2	2	2	2	
18	5WG-F473J-01	电线 WIRE	1	1	1	1	
19	98502-05012	十字螺钉 SCREW, PAN HEAD	1	1	1	1	
20	4S5-F7483-00	衬垫 1 MAT 1	1	1			
	4S5-F7483-10	衬垫 1 MAT 1			1	1	
21	4S5-F7311-10	侧支承 STAND, SIDE	1	1	1	1	
22	90109-08836	螺栓 BOLT	1	1	1	1	
23	95602-08200	自锁螺母 NUT, SELF-LOCKING	1	1	1	1	
24	90506-20816	拉簧 SPRING, TENSION	1	1	1	1	
25	4S5-X2748-F0-WL	护腿板嵌条 MOLD, FOOTREST	1	1			UR 幻银车用 UR FOR STDS
	4S5-X2748-F0-AL	护腿板嵌条 MOLD, FOOTREST	1	1			UR 黄车用 UR FOR CMY

FIG. 25 搁脚·支架

STAND & FOOTREST

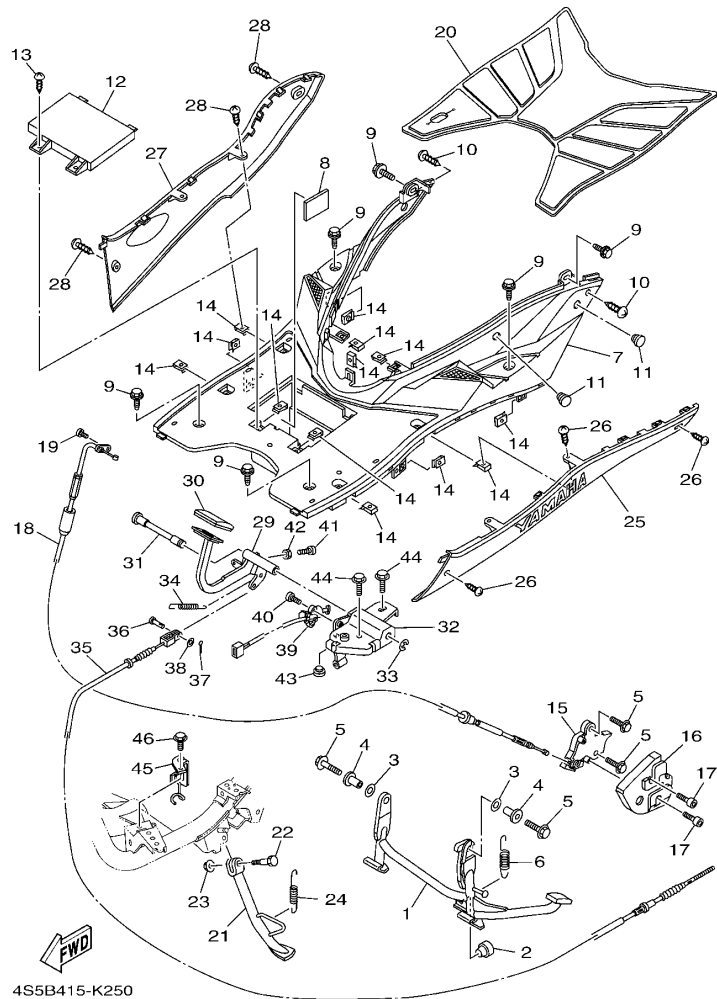

4S5B415-K250

参照 号码	零件号码 PART NO.	零件名称 DESCRIPTION	4SFE	4S5G	4S5H	4S5J	备注 REMARKS
25	4S5-X2748-F0-P7	护腿板嵌条 MOLD, FOOTREST	1	1			UR 金属蓝色车用 UR FOR BMC
	4S5-X2748-F0-P3	护腿板嵌条 MOLD, FOOTREST	1	1			UR 亮金属红色车用 UR FOR VRM5
	4S5-X2748-F0-P2	护腿板嵌条 MOLD, FOOTREST	1	1			UR 金属黑色车用 UR FOR SMX
	4S5-X2748-F0-P2	护腿板嵌条 MOLD, FOOTREST			1	1	UR 金属黑色 无光泽黑车用 UR SMX FOR MBL2
	4S5-X2748-H0-P8	护腿板嵌条 MOLD, FOOTREST			1	1	UR 无光泽金属蓝 浅蓝鸡尾白色 1 车用 UR MBM3 FOR BWC1
26	97702-50012	自攻螺钉 SCREW, TAPPING	4	4	4	4	
27	4S5-X2749-F0-WL	护腿板嵌条 2 MOLD, FOOTREST 2	1	1			UR 幻银车用 UR FOR STDS
	4S5-X2749-F0-AL	护腿板嵌条 2 MOLD, FOOTREST 2	1	1			UR 黄车用 UR FOR CMY
	4S5-X2749-F0-P7	护腿板嵌条 2 MOLD, FOOTREST 2	1	1			UR 金属蓝色车用 UR FOR BMC
	4S5-X2749-F0-P3	护腿板嵌条 2 MOLD, FOOTREST 2	1	1			UR 亮金属红色车用 UR FOR VRM5
	4S5-X2749-F0-P2	护腿板嵌条 2 MOLD, FOOTREST 2	1	1			UR 金属黑色车用 UR FOR SMX
	4S5-X2749-F0-P2	护腿板嵌条 2 MOLD, FOOTREST 2			1	1	UR 金属黑色 无光泽黑车用 UR SMX FOR MBL2
	4S5-X2749-H0-P8	护腿板嵌条 2 MOLD, FOOTREST 2			1	1	UR 无光泽金属蓝 浅蓝鸡尾白色 1 车用 UR MBM3 FOR BWC1
28	97702-50012	自攻螺钉 SCREW, TAPPING	4	4	4	4	
29	1CC-F7211-00	制动踏板 PEDAL, BRAKE		1	1		
30	1CC-F7285-00	盖 CAP	1	1			
31	1CC-F7212-00	制动踏板轴 SHAFT, BRAKE PEDAL	1	1			
32	1CC-F7263-00	托架 1 BRACKET 1	1	1			
33	99002-09600	卡环 CLIP	1	1			
34	90506-14803	拉簧 SPRING, TENSION	1	1			
35	1CC-F6361-00	制动器钢索 CABLE, BRAKE	1	1			
36	90240-06804	销 PIN, CLEVIS	1	1			
37	91402-20012	开口销 PIN, COTTER	1	1			
38	92902-06200	垫圈 WASHER	1	1			
39	5MH-H2566-11	开关侧支承 SWITCH, SIDE STAND	1	1			
40	90157-05029	大柱头螺钉 SCREW, PAN HEAD	2	2			
41	90154-06004	夹紧螺钉 SCREW, BINDING	1	1			

FIG. 25 搁脚·支架

STAND & FOOTREST

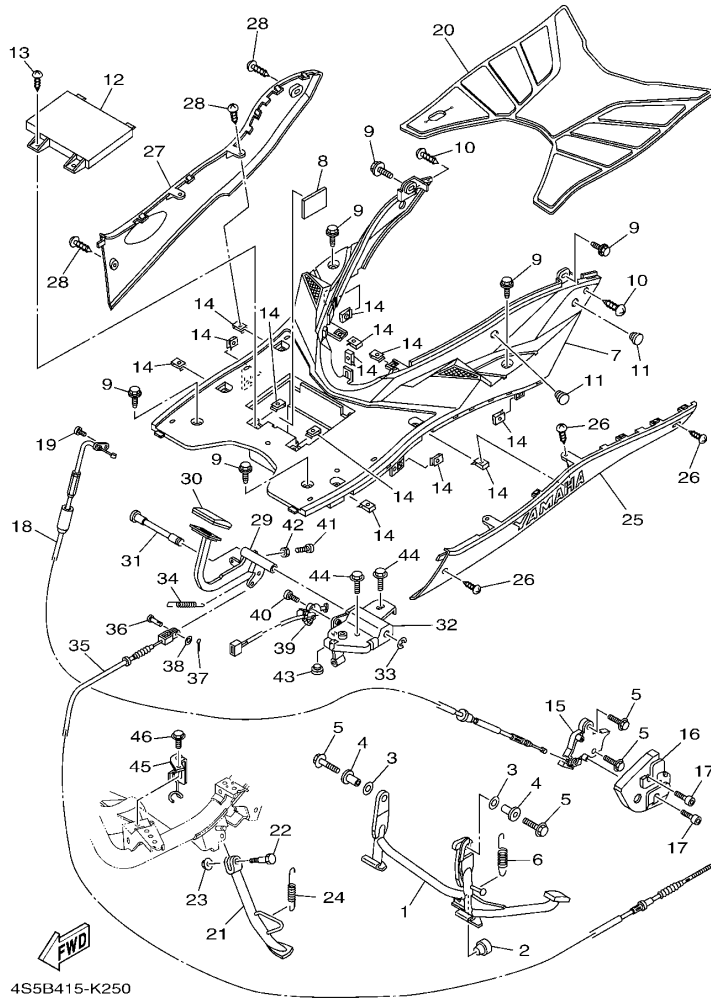

参照 号码	零件号码 PART NO.	零件名称 DESCRIPTION	4SF	4SG	4SH	4SJ	备注 REMARKS
42	90170-06020	螺母 NUT		1		1	
43	5MH-F7114-00	主支承限位板 STOPPER, MAIN STAND		1		1	
44	95802-10014	凸缘螺栓 BOLT, FLANGE		2		2	
45	5MH-F637G-01	钢索支架 HOLDER, WIRE		1		1	
46	95802-06010	凸缘螺栓 BOLT, FLANGE		1		1	

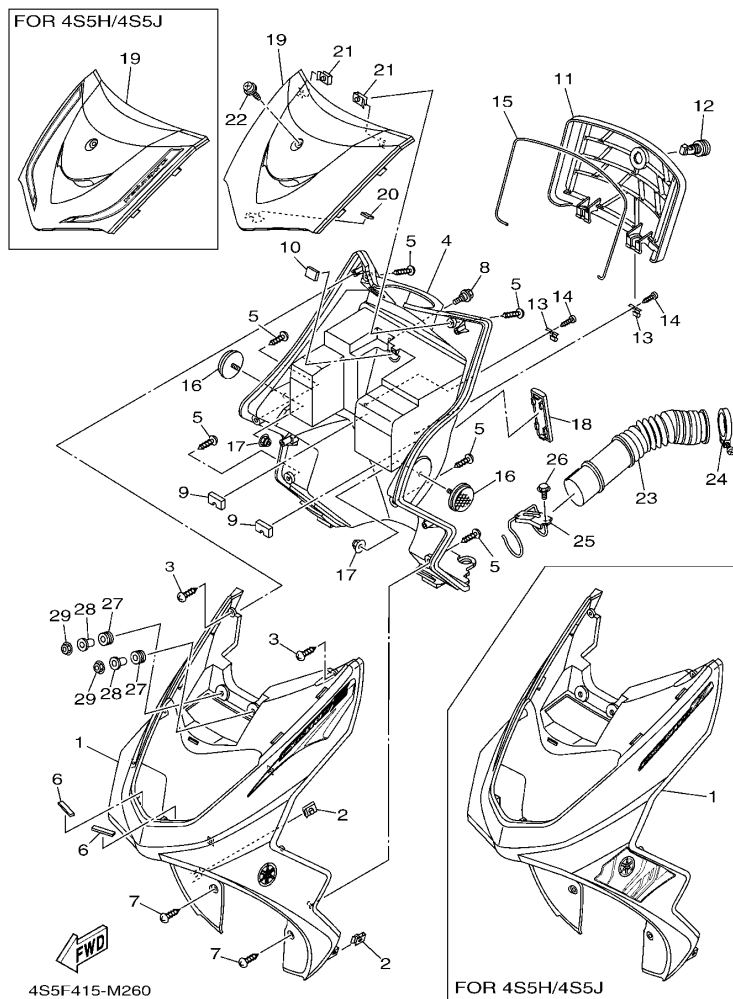

FIG. 26 护腿

LEG SHIELD

参照 号码	零件号码 PART NO.	零件名称 DESCRIPTION	4SF	4SG	4SH	4SJ	备注 REMARKS
1	4S5-X2831-F0-WL	护腿板 1 LEG SHIELD 1	1	1			UR 幻银车用 UR FOR STDS
	4S5-X2831-F0-AL	护腿板 1 LEG SHIELD 1	1	1			UR 黄车用 UR FOR CMY
	4S5-X2831-F0-P7	护腿板 1 LEG SHIELD 1	1	1			UR 金属蓝车用 UR FOR BMC
	4S5-X2831-F0-P3	护腿板 1 LEG SHIELD 1	1	1			UR 亮金属红车用 UR FOR VRM5
	4S5-X2831-F0-P2	护腿板 1 LEG SHIELD 1	1	1			UR 金属黑色车用 UR FOR SMX
	4S5-X2831-H0-P8	护腿板 1 LEG SHIELD 1			1	1	UR 无光泽黑车用 UR FOR MBL2
	4S5-X2831-H0-P9	护腿板 1 LEG SHIELD 1			1	1	UR 浅蓝鸡尾白色 1 车用 UR FOR BWC1
2	90183-05818	弹性螺母 NUT, SPRING	2	2	2	2	
3	97702-50016	自攻螺钉 SCREW, TAPPING	2	2	2	2	
4	4S5-F8312-01	护腿板 2 LEG SHIELD 2	1	1			
	4S5-F8312-11	护腿板 2 LEG SHIELD 2		1		1	
5	97702-50016	自攻螺钉 SCREW, TAPPING	6	6	6	6	
6	4S5-F1541-00	减震垫 1 DAMPER 1	2	2	2	2	
7	97702-50012	自攻螺钉 SCREW, TAPPING	2	2	2	2	
8	90109-06822	螺栓 BOLT	1	1	1	1	
9	4S5-F834J-00	盖 2 CAP 2	2	2	2	2	
10	5MH-F834V-00	保护件 1 PROTECTOR 1	1	1	1	1	
11	4S5-F8313-00	盖 LID	1	1	1	1	
12	5MH-F1780-01	锁紧装置组合 LOCK ASSY	1	1	1	1	
13	4KL-F1796-01	铰链 HINGE	2	2	2	2	
14	97702-40512	自攻螺钉 SCREW, TAPPING	2	2	2	2	
15	4S5-F8371-00	减震垫 DAMPER	1	1	1	1	
16	4KL-H5131-20	后反射镜 1 REFLECTOR, REAR 1	2	2	2	2	
17	95602-05200	自锁螺母 NUT, SELF-LOCKING	2	2	2	2	
18	4KL-F8349-11	盖 CAP	1	1	1	1	
19	4S5-F8345-00-P2	嵌条 1 MOLE 1	1	1			金属黑色 SMX
	4S5-F8345-00-P5	嵌条 1 MOLE 1	1	1			无光泽黑 MBL2

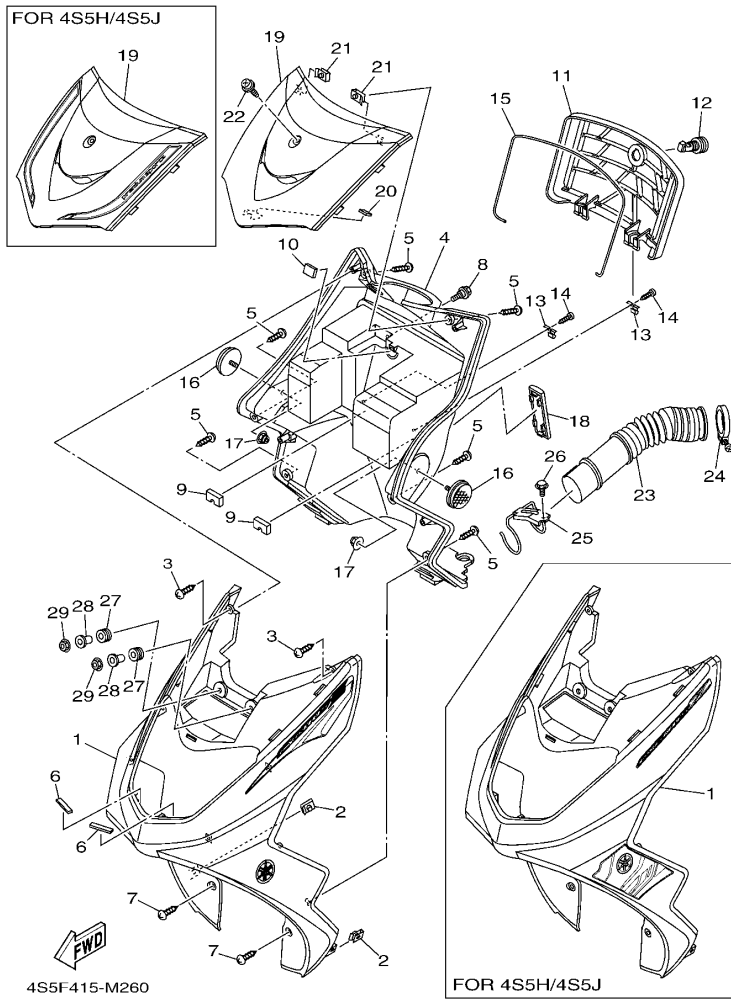

FIG. 26 护腿

LEG SHIELD

参照 号码	零件号码 PART NO.	零件名称 DESCRIPTION	4SF	4SG	4SH	4SJ	备注 REMARKS
19	4S5-X2834-H0-P3	嵌板 1 MOLE 1			1	1	无光泽浅灰金属黄 MNYM1 无光泽金属蓝 MBM3
	4S5-X2834-H0-P4	嵌板 1 MOLE 1			1	1	
20	4S5-F8372-00	避震垫 DAMPER	1	1	1	1	
21	90183-05818	弹性螺母 NUT, SPRING	2	2	2	2	
22	90159-06812	带垫螺钉 SCREW, WITH WASHER	1	1	1	1	
23	5WG-F1557-00	空气管道 DUCT, AIR	1	1	1	1	
24	5WG-F1823-02	软管夹 CLAMP, HOSE	1	1	1	1	
25	5WG-F1161-01	钢索支架 HOLDER, CABLE	1	1	1	1	
26	95802-06012	凸缘螺栓 BOLT, FLANGE	1	1	1	1	
27	90480-13398	橡胶垫 GROMMET	2	2	2	2	
28	90387-06160	轴套 COLLAR	2	2	2	2	
29	95702-06500	螺母 NUT, FLANGE	2	2	2	2	

FIG. 27 手把杆上侧盖

COVER

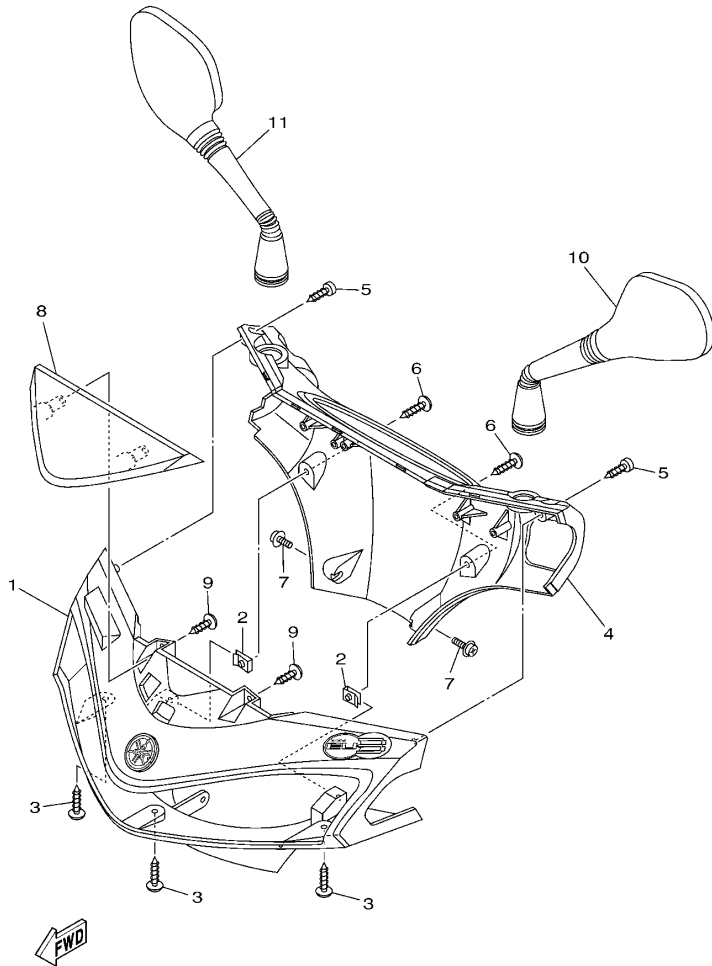

4S5F415-M270

参照 号码	零件号码 PART NO.	零件名称 DESCRIPTION	4SF	4SG	4SH	4SJ	备注 REMARKS
1	4S5-X2610-F0-WL	手把杆上侧盖 1 COVER, HANDLEBAR UPPER 1	1				UR 幻银车用 UR FOR STDS
	4S5-X2610-F0-AL	手把杆上侧盖 1 COVER, HANDLEBAR UPPER 1	1				UR 黄车用 UR FOR CMY
	4S5-X2610-F0-P7	手把杆上侧盖 1 COVER, HANDLEBAR UPPER 1	1				UR 金属蓝车用 UR FOR BMC
	4S5-X2610-F0-P3	手把杆上侧盖 1 COVER, HANDLEBAR UPPER 1	1				UR 亮金属红车用 UR FOR VRM5
	4S5-X2610-F0-P2	手把杆上侧盖 1 COVER, HANDLEBAR UPPER 1	1				UR 金属黑色车用 UR FOR SMX
	4S5-X2610-G0-WL	手把杆上侧盖 1 COVER, HANDLEBAR UPPER 1		1			UR 幻银车用 UR FOR STDS
	4S5-X2610-G0-AL	手把杆上侧盖 1 COVER, HANDLEBAR UPPER 1		1			UR 黄车用 UR FOR CMY
	4S5-X2610-G0-P7	手把杆上侧盖 1 COVER, HANDLEBAR UPPER 1		1			UR 金属蓝车用 UR FOR BMC
	4S5-X2610-G0-P3	手把杆上侧盖 1 COVER, HANDLEBAR UPPER 1		1			UR 亮金属红车用 UR FOR VRM5
	4S5-X2610-G0-P2	手把杆上侧盖 1 COVER, HANDLEBAR UPPER 1		1			UR 金属黑色车用 UR FOR SMX
	4S5-X2610-H0-P8	手把杆上侧盖 1 COVER, HANDLEBAR UPPER 1			1		UR 无光泽黑车用 UR FOR MBL2
	4S5-X2610-H0-P9	手把杆上侧盖 1 COVER, HANDLEBAR UPPER 1			1		UR 浅蓝鸡尾白色 1 车用 UR FOR BWC1
	4S5-X2610-J0-P8	手把杆上侧盖 1 COVER, HANDLEBAR UPPER 1				1	UR 无光泽黑车用 UR FOR MBL2
	4S5-X2610-J0-P9	手把杆上侧盖 1 COVER, HANDLEBAR UPPER 1				1	UR 浅蓝鸡尾白色 1 车用 UR FOR BWC1
2	90183-05818	弹性螺母 NUT, SPRING	2	2	2	2	
3	97702-50016	自攻螺钉 SCREW, TAPPING	3	3	3	3	
4	4S5-F6145-01	手把杆上侧盖 2 COVER, HAND UPPER 2	1	1	1	1	
5	97780-50512	自攻螺钉 SCREW, TAPPING	2	2	2	2	
6	97702-50016	自攻螺钉 SCREW, TAPPING	2	2	2	2	
7	97602-05216	带垫圈大柱头螺钉 SCREW, PAN HEAD WITH WASHER	2	2	2	2	
8	4S5-F6234-10-P1	隔板 SCREEN	1	1			金属黑色 SMX
	4S5-F6234-10-P3	隔板 SCREEN	1	1			无光泽黑 MBL2
	4S5-F6234-10-P0	隔板 SCREEN			1	1	无光泽浅灰金属黄 MNYM1
	4S5-F6234-10-P2	隔板 SCREEN			1	1	无光泽金属蓝 MBM3
9	97702-50012	自攻螺钉 SCREW, TAPPING	2	2	2	2	
10	4P7-F6280-10	后视镜组合 (左边) REAR VIEW MIRROR ASSY (LEFT)	1	1	1	1	
11	4P7-F6290-10	后视镜组合 (右边) REAR VIEW MIRROR ASSY (RIGHT)	1	1	1	1	

FIG. 28 发电机

GENERATOR

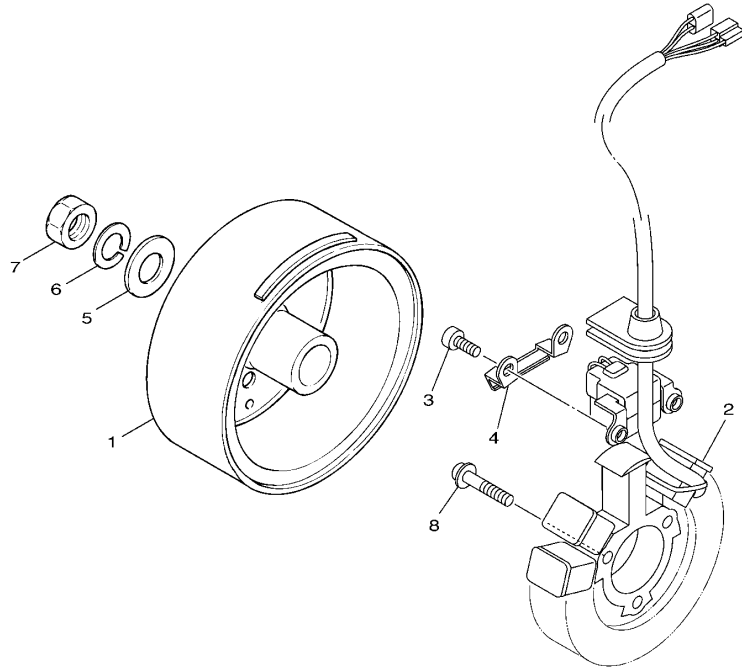

参照 号码	零件号码 PART NO.	零件名称 DESCRIPTION	4SF6	4SSG	4SHH	4SJ	备注 REMARKS
1	4P7-H5550-01	转子组合 ROTOR ASSY	1	1	1	1	
2	4S5-H1410-00	定子组合 STATOR ASSY	1	1	1	1	
3	91312-06016	螺栓 BOLT	2	2	2	2	
4	4S5-E5113-00	面板 PLATE	1	1	1	1	
5	92902-12600	面板垫圈 WASHER, PLATE	1	1	1	1	
6	92902-12100	弹簧垫圈 WASHER, SPRING	1	1	1	1	
7	90170-12181	螺母 NUT	1	1	1	1	
8	97602-06335	带垫圈大柱头螺钉 SCREW, PAN HEAD WITH WASHER	3	3	3	3	

FIG. 29 启动电机

STARTING MOTOR

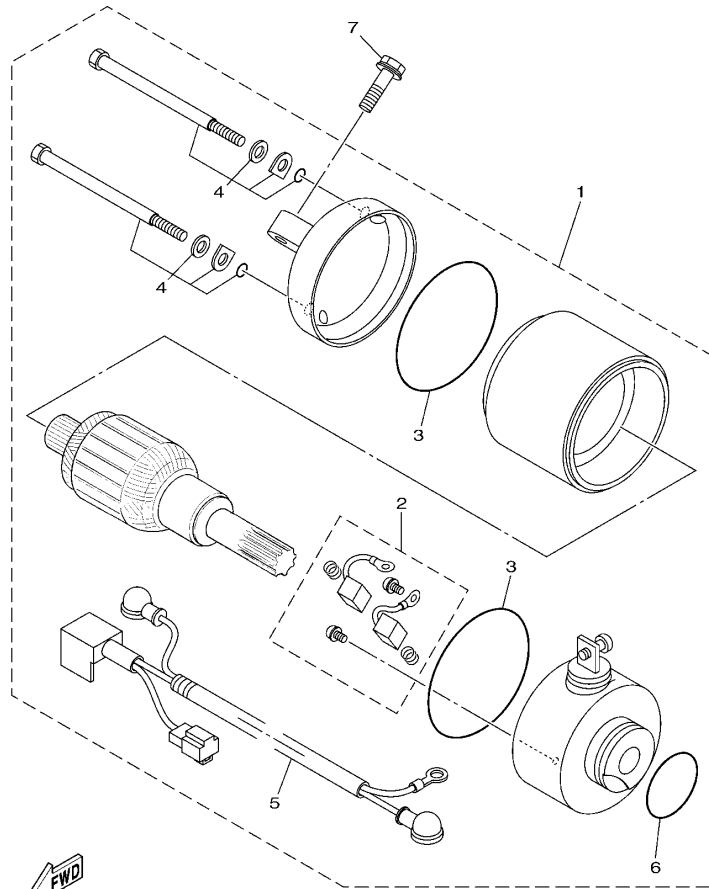

4P71516-E290

参照 号码	零件号码 PART NO.	零件名称 DESCRIPTION	4SF	4SG	4SH	4SJ	备注 REMARKS
1	5WG-H1800-01	启动电机组合 STARTING MOTOR ASSY	1	1	1	1	
2	4KL-H1801-00	.碳刷组件 .BRUSH SET	1	1	1	1	
3	93210-55669	.O型环 .O-RING	2	2	2	2	
4	4KL-H1828-00	.组合螺钉 .SCREW 2	2	2	2	2	
5	5WG-H183G-00	.导线组件 .CORD COMP.	1	1	1	1	
6	93210-26668	.O型环 .O-RING	1	1	1	1	
7	97502-06525	带垫螺栓 BOLT, WITH WASHER	2	2	2	2	

FIG. 30 转向灯

FLASHER LIGHT

参照 号码	零件号码 PART NO.	零件名称 DESCRIPTION	4SFE	4SSG	4SHH	4S5J	备注 REMARKS
1	4S5-H3301-01	前闪烁器组合 1 FRONT FLASHER LIGHT ASSY 1	1	1	1	1	
2	4S5-H3311-00	. 转向灯灯泡 . BULB, FLASHER (12V-10W)	2	2	2	2	
3	4S5-H331E-00	. 缆索组合 . CORD ASSY	1	1	1	1	
4	4S5-H332E-00	. 缆索组合 . CORD ASSY	1	1	1	1	
5	90183-05818	弹性螺母 NUT, SPRING	3	3	3	3	
6	97702-50016	自攻螺钉 SCREW, TAPPING	3	3	3	3	

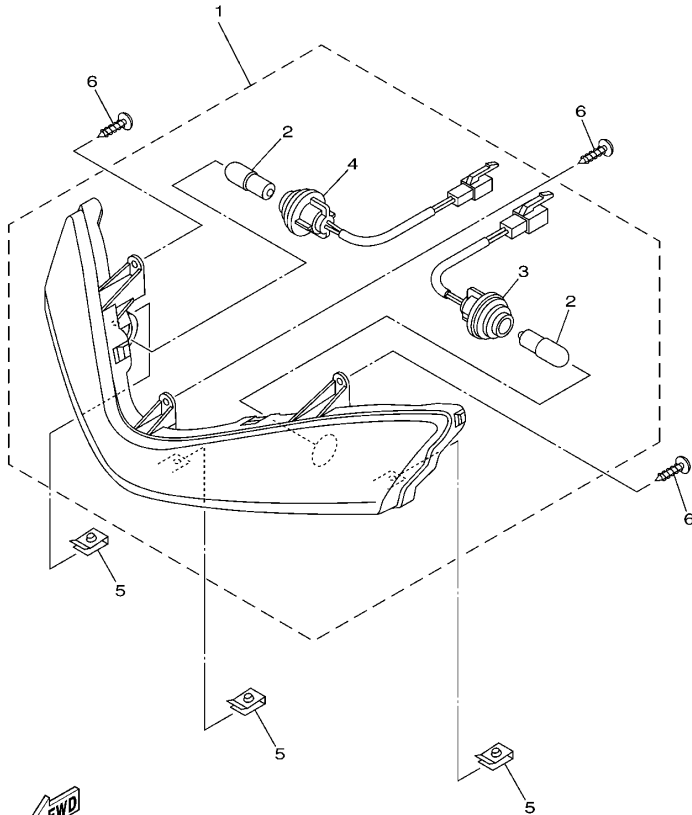

FWD
4S51415-F300

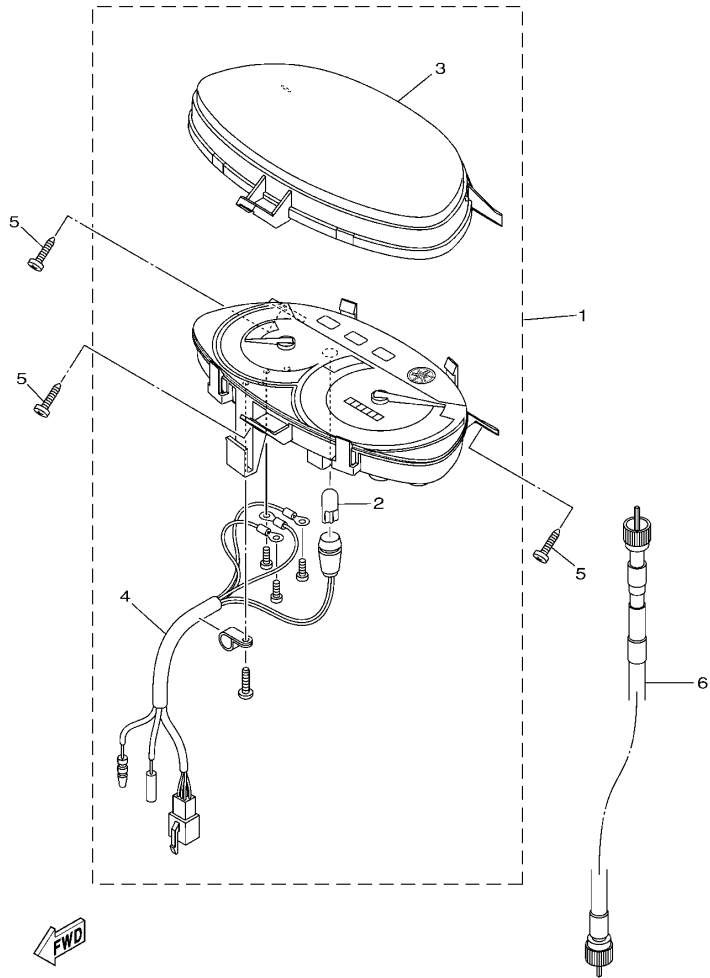

4S5B415-K310

FIG. 31 仪表

METER

参照 号码	零件号码 PART NO.	零件名称 DESCRIPTION	4SF	4SG	4SH	4SJ	备注 REMARKS
1	4S5-H3510-31	测速计组合 SPEEDOMETER ASSY	1	1	1	1	
2	1CC-H3517-10	. 灯泡 (T10 12V-3.4W) . BULB (T10 12V-3.4W)	1	1	1	1	
3	1CC-H353K-01	. 玻璃面板 . GLASS PLATE	1	1	1	1	
4	1CC-H3509-10	. 导线组合 . SOCKET CORD ASSY	1	1	1	1	
5	97702-50016	自攻螺钉 SCREW, TAPPING	3	3	3	3	
6	4S5-H3550-01	速度计软轴组合 SPEEDOMETER CABLE ASSY	1	1	1	1	

FIG. 32 前大灯

HEADLIGHT

参照 号码	零件号码 PART NO.	零件名称 DESCRIPTION	4SFE	4SFG	4SHH	4SJ	备注 REMARKS
1	4S5-H4310-01	大灯组件 HEADLIGHT UNIT ASSY	1	1	1	1	
2	4S5-H4314-00	.前照灯灯泡 (12V-35/35W) .BULB, HEADLIGHT (12V-35/35W)	1	1	1	1	
3	4S5-H4347-00	.灯泡 .BULB (12V-5W)	1	1	1	1	
4	4S5-H4312-01	.导线组合 .CORD ASSY	1	1	1	1	
5	4S5-H4378-00	.盖 .CAP	1	1	1	1	
6	97702-60020	自攻螺钉 SCREW, TAPPING	4	4	4	4	

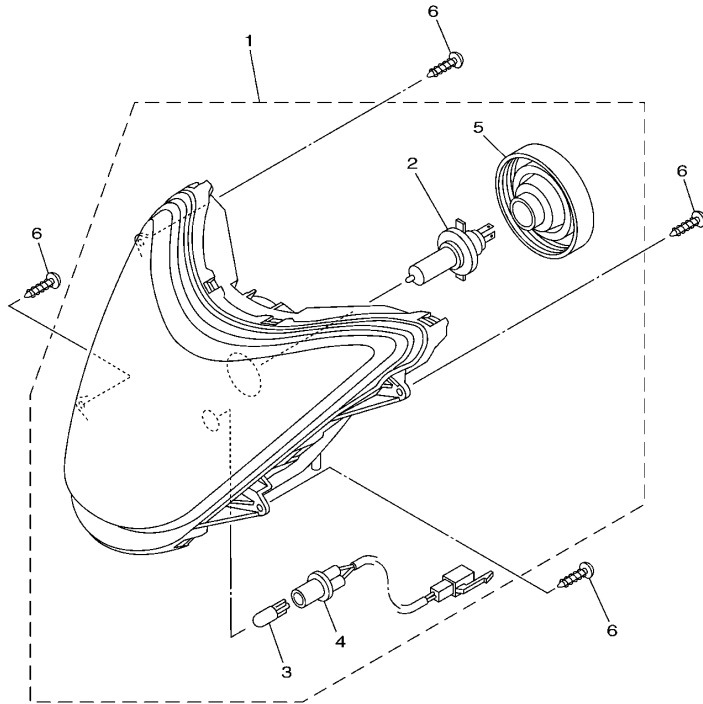

4S51415-F320

FIG. 33 尾灯

TAILLIGHT

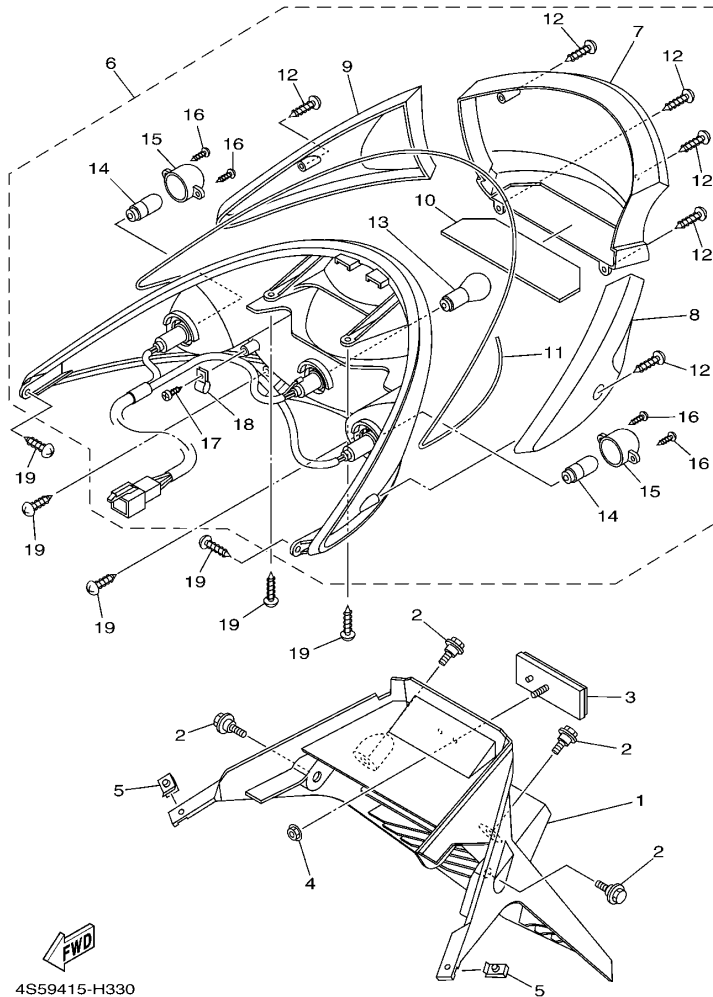

参照 号码	零件号码 PART NO.	零件名称 DESCRIPTION	4SF	4SG	4SH	4SJ	备注 REMARKS
1	4S5-F1685-00	车牌托架 BRACKET, LICENSE	1	1	1	1	
2	90109-06822	螺栓 BOLT	4	4	4	4	
3	4P7-H5130-20	后反射镜组合 REAR REFLECTOR ASSY	1	1	1	1	
4	95602-05200	自锁螺母 NUT, SELF-LOCKING	1	1	1	1	
5	90183-05818	弹性螺母 NUT, SPRING	2	2	2	2	
6	4S5-H4700-02	尾灯组合 TAILLIGHT ASSY	1	1	1	1	
7	4S5-H4721-01	尾灯透镜 .LENS, TAILLIGHT	1	1	1	1	
8	4S5-H3332-01	闪烁器镜面 .LENS, FLASHER	1	1	1	1	
9	4S5-H3342-01	闪烁器镜面 2 .LENS, FLASHER 2	1	1	1	1	
10	4S5-H4743-00	牌照灯镜头 .LENS, LICENCE LIGHT	1	1	1	1	
11	4S5-H4723-00	尾灯镜面衬垫 .GASKET, TAIL LENS	1	1	1	1	
12	4S5-H4724-00	镜面安装螺钉 .SCREW, LENS FITTING	6	6	6	6	
13	4S5-H4714-00	灯泡 .BULB (12V-21/5W)	1	1	1	1	
14	4S5-H3311-00	转向灯灯泡 .BULB, FLASHER (12V-10W)	2	2	2	2	
15	4S5-H333M-00	闪烁灯泡罩 .LENS, INNER 2	2	2	2	2	
16	4S5-H3333-00	镜面安装螺钉 .SCREW, LENS FITTING	4	4	4	4	
17	4S5-H4726-00	螺钉 .SCREW	1	1	1	1	
18	4S5-H4772-00	垫 .PLATE, CLAMP	1	1	1	1	
19	97702-50016	自攻螺钉 SCREW, TAPPING	6	6	6	6	

FIG. 34 手柄开关·杆

HANDLE SWITCH & LEVER

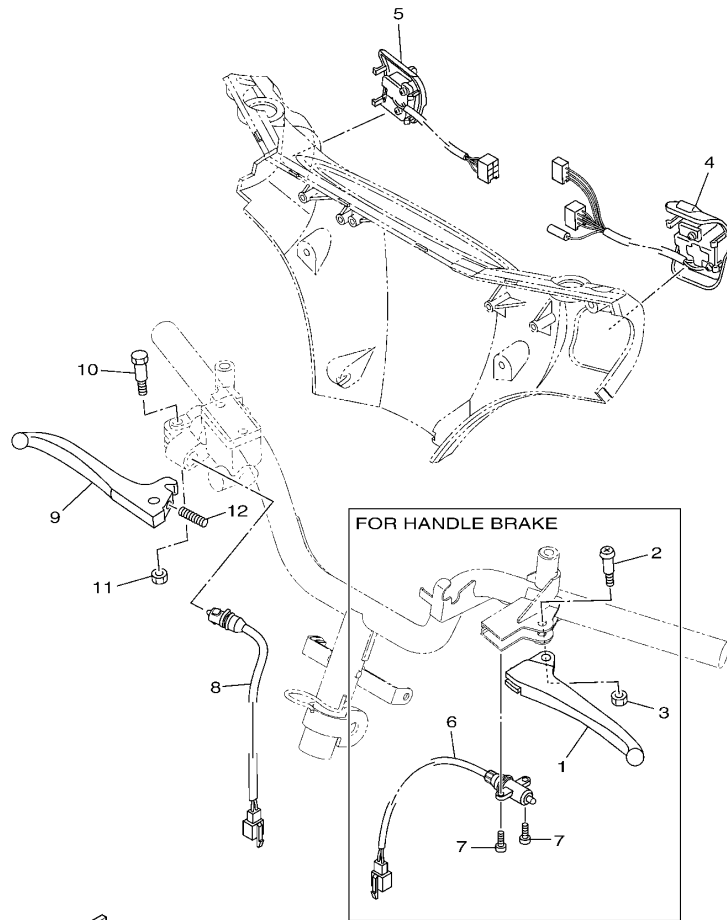



4S5B415-K340

参照 号码	零件号码 PART NO.	零件名称 DESCRIPTION	4S5F	4S5G	4S5H	4S5J	备注 REMARKS
1	5WY-H3912-20	手柄 1 LEVER 1	1		1		
2	90157-05812	大柱头螺钉 SCREW, PAN HEAD	1		1		
3	95602-05100	锁紧螺母 NUT, U	1		1		
4	4S0-H3963-01	手把开关 3 (右边) SWITCH, HANDLE 3	1	1	1	1	
5	4S0-H3975-01	手把开关 2 SWITCH, HANDLE 2	1	1	1	1	
6	1CC-H3980-00	前制动开关组合 FRONT STOP SWITCH ASSY	1		1		
7	98502-03008	十字螺钉 SCREW, PAN HEAD	2		2		
8	5MH-H3980-11	前制动开关组合 FRONT STOP SWITCH ASSY	1	1	1	1	
9	4S0-H3922-10	手柄 2 LEVER 2	1	1	1	1	
10	90109-06255	螺栓 BOLT	1	1	1	1	
11	95602-06100	锁紧螺母 NUT, U	1	1	1	1	
12	90501-10312	压簧 SPRING, COMPRESSION	1	1	1	1	

FIG. 35 电气系统 1

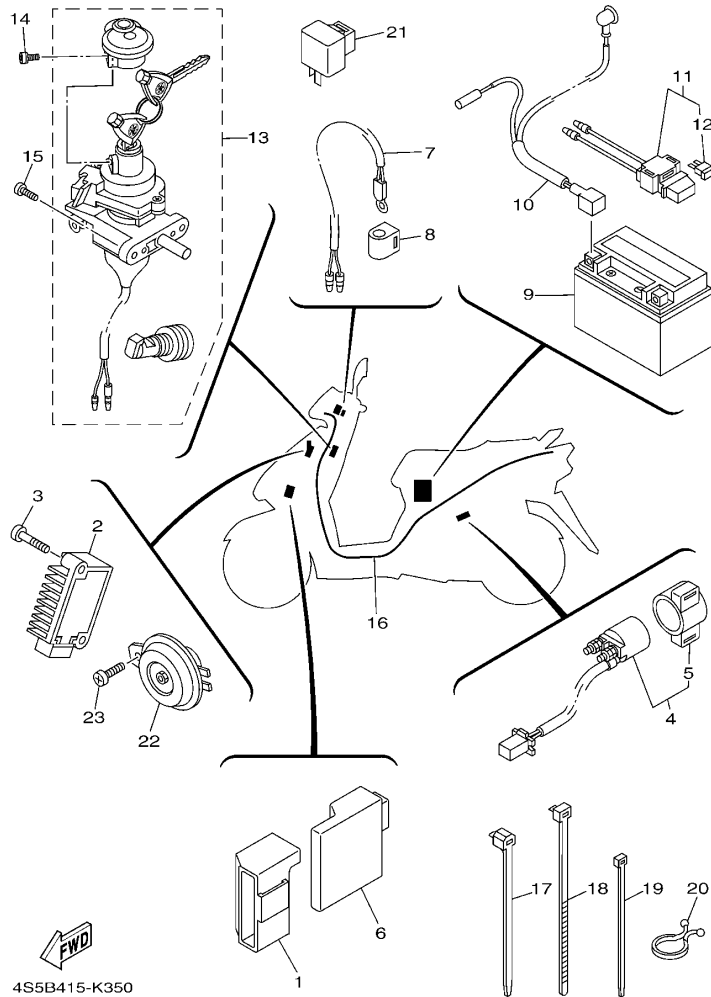
ELECTRICAL 1



4S5B415-K350

参照 号码	零件号码 PART NO.	零件名称 DESCRIPTION	4SFE	4SSG	4SHH	4SJ	备注 REMARKS
1	4S0-H5546-00	箍带 BAND	1	1	1	1	
2	5WG-H1960-00	整流调节器 RECTIFIER & REGULATOR ASSY	1	1	1	1	
3	98502-06025	十字螺钉 SCREW, PAN HEAD	2	2	2	2	
4	5WG-H1940-30	起动机继电器组合 STARTER RELAY ASSY	1	1	1	1	
5	5WG-H1952-10	继电器支架 .HOLDER, RELAY	1	1	1	1	
6	5WY-H5540-41	CDI 总成 C.D.I. UNIT ASSY	1	1	1	1	
7	1CC-H5700-00	温度传感器 THERMISTOR ASSY	1	1	1	1	
8	4S0-H3836-00	卡箍 BAND	1	1	1	1	
9	4KL-H2100-01	蓄电池组合 BATTERY ASSY (GTX7A-BS)	1	1	1	1	
10	5WG-H2115-00	正极导线 WIRE, PLUS LEAD	1	1	1	1	
11	4KL-H2170-10	保险丝盒组合 FUSE BOX ASSY	1	1	1	1	
12	4KL-H2151-10	保险丝 .FUSE (15A-BL)	1	1	1	1	
13	4S5-X8250-13	锁组合 LOCK ASSY.	1	1	1	1	
14	97602-05212	带垫圈大柱头螺钉 SCREW, PAN HEAD WITH WASHER	1	1	1	1	
15	98502-06016	十字螺钉 SCREW, PAN HEAD	2	2	2	2	
16	4S5-H2590-20	电缆总成 WIRE HARNESS ASSY	1	1			
	4S5-H2590-30	电缆总成 WIRE HARNESS ASSY		1		1	
17	90464-12812	线夹 CLAMP	5	5	5	5	
18	90464-20809	线夹 CLAMP	1	1	1	1	
19	90465-13152	夹箍 CLAMP	2	2	2	2	
20	90464-23811	线夹 CLAMP	1	1	1	1	
21	5VL-H3350-21	闪烁继电器组合 FLASHER RELAY ASSY	1	1	1	1	
22	5WG-H3371-01	电喇叭 HORN	1	1	1	1	
23	98502-06010	十字螺钉 SCREW, PAN HEAD	1	1	1	1	

FIG. 36 电气系统 2

ELECTRICAL 2

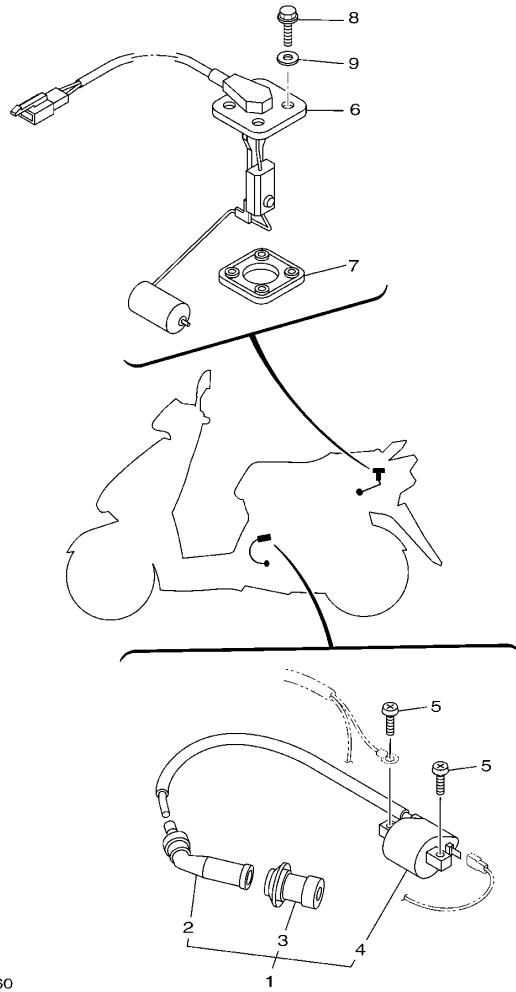

参照 号码	零件号码 PART NO.	零件名称 DESCRIPTION	4SF6	4S6G	4S6H	4S6J	备注 REMARKS
1	4P7-X8231-10	点火线圈组合 IGN. COIL ASSY.	1	1	1	1	
2	4KL-H2370-01	火花塞帽组合 . PLUG CAP ASSY	1	1	1	1	
3	4KL-H2372-00	塞帽密封 . SEAL, PLUG CAP	1	1	1	1	
4	4P7-H2310-00	点火线圈组合 . IGNITION COIL ASSY	1	1	1	1	
5	98502-06018	十字螺钉 SCREW, PAN HEAD	2	2	2	2	
6	4S5-H5752-10	燃油表传感装置组合 SENDER UNIT ASSY, FUEL METER	1	1	1	1	
7	4KL-H5753-00	传感器垫圈 GASKET, SENDER UNIT	1	1	1	1	
8	90105-05804	凸缘螺栓 BOLT, FLANGE	4	4	4	4	
9	90201-053E0	平垫圈 WASHER, PLATE	4	4	4	4	

2BK2200-M360

零件号码索引
NUMERICAL INDEX

零件号码 PART NO.	参照 号码	零件号码 PART NO.	参照 号码	零件号码 PART NO.	参照 号码	零件号码 PART NO.	参照 号码	零件号码 PART NO.	参照 号码	零件号码 PART NO.	参照 号码
22F-12159-00	3 - 9	5MH-E3475-00	5 - 7	4S5-E490J-10	7 - 3	4KL-E6626-20	11 - 30	4S5-F2210-10	16 - 1	4S5-F4313-00	18 - 18
4JH-14562-00	7 - 28	5WG-E3542-10	8 - 31	5WG-E490K-00	7 - 16	4KL-E7410-10	12 - 1	4KL-F2216-00	9 - 3	4S0-F4314-00	18 - 21
4S5-E1111-00	1 - 1	5WG-E3556-10	6 - 21	5WG-E4933-00	7 - 4	5WG-E7420-00	12 - 5	5WG-F3110-00	17 - 6	4S5-F4315-00	18 - 25
5WG-E111F-00	3 - 23	5MH-E3569-00	4 - 11	4S5-E4940-00	7 - 2	4KL-E7465-00	11 - 23		17 - 20	5WG-F4500-01	18 - 6
5WG-E1145-00	3 - 14	5MH-E3575-01	6 - 5	5TY-E4943-28	7 - 7	4KL-E7465-20	11 - 24	4KL-F3111-00	17 - 12	4S0-F4610-01	18 - 5
5WG-E1155-00	1 - 11	5WG-E3575-01	6 - 19	5WG-E4947-00	7 - 5	4KL-E7601-21	11 - 7		17 - 26	5WY-F4633-00	19 - 8
4S5-E1160-02	1 - 7	5WG-E3585-00	6 - 1	4S5-E4948-00	7 - 8	4KL-E7602-22	11 - 20	4S5-F3141-00	17 - 7	5WG-F4726-00	19 - 3
5WG-E1165-00	1 - 9	5WG-E3595-00	6 - 20	5WG-E4958-00	7 - 19	4KL-E7611-20	11 - 18		17 - 21	4S5-F4730-01	19 - 1
5WG-E1181-01	1 - 19	5WG-E3769-00	9 - 43	5WG-E4967-00	7 - 25	4KL-E7620-20	11 - 8	4TU-F3144-00	17 - 31	4S5-F4730-12	19 - 1
4S5-E1185-01	1 - 8	4S5-E4105-00	7 - 9	1B6-E4984-00	7 - 15	4KL-E7623-20	11 - 10	4GU-F3145-00	17 - 4	5WG-F473J-01	25 - 18
4KL-E1186-00	1 - 14	5WG-E4107-00	7 - 10	5WG-E4985-00	7 - 11	4KL-E7632-21	11 - 9		17 - 18	5WY-F4742-00	19 - 7
5WG-E1310-01	1 - 23	4S5-E4137-00	7 - 27	4S5-E4987-00	1 - 26	4KL-E7641-00	11 - 17	5AP-F3147-00	17 - 13	4S5-F475M-01	19 - 2
5WG-E1351-10	1 - 24	5WG-E4147-00	7 - 21	4S5-E5111-00	9 - 1	4KL-E7645-20	11 - 12		17 - 27	4S5-F4780-01	19 - 10
5WG-E1400-60	2 - 1	5WG-E414G-00	7 - 6	4S5-E5113-00	28 - 4	4KL-E7653-20	11 - 11	5AP-F3153-00	17 - 5	4S5-F478E-01	19 - 12
5WG-E1400-70	2 - 1	5WG-E4196-00	7 - 26	4S5-E5121-00	9 - 2	4KL-E7660-21	11 - 21		17 - 19	4S5-F4812-10-98	19 - 14
4KL-E1445-00	2 - 3	5WG-E4243-00	7 - 23	5WG-E5191-01	9 - 25	4KL-E7664-20	11 - 25	2D0-F3166-00	17 - 9	4S5-F4812-10-P0	19 - 14
5MH-E1603-00	2 - 9	5WG-E4275-00	7 - 18	5WG-E5317-01	13 - 3	4KL-E7668-21	11 - 31		17 - 23	4S5-F4812-10-P3	19 - 14
4S5-E1631-00	2 - 6	5WG-E4370-00	7 - 22	4KL-E5351-10	5 - 12	4KL-E7670-20	11 - 22	5WG-F3170-00	17 - 8	4S5-F5168-01-33	20 - 7
1CC-E1633-10	2 - 7	4S5-E4410-01	6 - 6	4S5-E5362-02	9 - 42	4KL-E7674-20	11 - 26		17 - 22	5WG-F5181-11	20 - 10
5WG-E2111-01	3 - 1	4S5-E4412-00	6 - 8	4KL-E5363-00	9 - 14	4KL-E7683-20	11 - 27	4KL-F3191-10	17 - 14	4S5-F5190-11	20 - 12
5WG-E2113-00	3 - 5	4S5-E443E-00	6 - 13	5MH-E5371-00	9 - 4	4KL-E7684-20	11 - 28		17 - 28	5WG-F5315-00	20 - 2
4S5-E2116-00	3 - 4	5WG-E443E-01	6 - 11	5WG-E5404-01	9 - 37	4S5-F1110-20	13 - 1	4KL-F3192-10	17 - 15	5WG-F5326-01	22 - 14
5WG-E2117-00	3 - 7	5WY-E4445-00	8 - 6	4P7-E5407-00	9 - 36	4S5-F1110-30	13 - 1		17 - 29	4KL-F5338-10-33	22 - 1
5WG-E2118-00	3 - 6	4S5-E4451-01	6 - 10	5WG-E5411-40	9 - 20	5WG-F1161-01	26 - 25	1CC-F3317-10	17 - 44	4KL-F533A-01	22 - 11
5WG-E2119-00	3 - 3	4S5-E4453-00	6 - 9	5WG-E5417-01	9 - 28	4S5-F116F-00	13 - 14	4S5-F331E-01	17 - 50	5MH-F5351-01	22 - 9
5WG-E2121-00	3 - 2	4S5-E4467-00	6 - 15	4KL-E5421-00	9 - 16	5WG-F118W-00	13 - 7	4S5-F3340-01	17 - 30	4KL-F5355-01	22 - 12
5WG-E2151-01	3 - 8	4S5-E4476-00	6 - 16	5WG-E5451-10	9 - 21	5WG-F1410-10	13 - 10	4RT-F3346-00	17 - 33	3D9-F580U-01	21 - 3
1CC-E2156-10	3 - 11	5WG-E4504-00	7 - 14	5WG-E5453-10	9 - 29	5WG-F1481-01	13 - 8	5LK-F3356-00	17 - 10	4S5-F580U-01	21 - 3
5MH-E2157-01	3 - 26	5WG-E4548-00	7 - 12	5WG-E5455-00	9 - 26	5WG-F1482-01	13 - 11		17 - 24	5WG-F582U-40	21 - 1
5WG-E2170-00	3 - 12	5WG-E4592-00	7 - 13	4KL-E5461-10	9 - 17	4S5-F1511-01-AL	14 - 1	4KL-F3411-00	17 - 38	4KL-F5852-00	24 - 5
5WG-E2176-00	3 - 13	4S5-E4610-20	8 - 1	5WG-E5471-01	9 - 34	4S5-F1511-01-P2	14 - 1	4TU-F3411-00	17 - 32	4KL-F5854-00	24 - 3
4KL-E2210-00	3 - 19	4KL-E4613-10	8 - 10	5WG-E5472-00	9 - 39	4S5-F1511-01-P3	14 - 1	4KL-F3412-00	17 - 35	4KL-F585B-00	24 - 4
5MH-E2213-10	3 - 21	5WY-E4617-00	8 - 8	5WG-E5521-00	10 - 3	4S5-F1511-01-P7	14 - 1	4KL-F3412-10	17 - 37	4KL-F5867-00	24 - 8
4KL-E2231-00	3 - 17	4S5-E4708-10	8 - 2	4KL-E5524-00	10 - 7	4S5-F1511-01-WL	14 - 1	5MH-F3416-01	17 - 40	4KL-F5870-21	24 - 1
4KL-E2232-00	3 - 20	5WY-E4759-01	8 - 7	5MH-E5532-00	10 - 5	4S5-F1541-00	26 - 6	5WG-F3418-01	17 - 43	4S5-F5872-02	24 - 10
4KL-E2241-00	3 - 18	5WB-E4766-10	8 - 4	4KL-E5570-01	10 - 10	4S5-F1552-00	14 - 3	5WG-F341E-00	17 - 36	4S5-F5875-01	17 - 46
4P7-E2611-00	4 - 13	5WY-E4779-01	8 - 5	4KL-E5601-11	10 - 12	5WG-F1557-00	26 - 23	5WG-F341E-10	17 - 39	52P-F5887-00	17 - 48
4P7-E2651-00	4 - 1	5WG-E4803-11	8 - 23	4KL-E5620-01	10 - 18	5WG-F1611-00	14 - 8	4TU-F3479-00	17 - 11	4KL-F5896-00	24 - 7
4P7-E2652-00	4 - 6	5WG-E4806-11	8 - 27	4KL-E5630-00	10 - 20	4S5-F1685-00	33 - 1		17 - 25	4KL-F589H-01	24 - 6
5WG-E2658-00	4 - 8	5WG-E4815-00	8 - 14	4KL-E5650-10	10 - 1	4S5-F1711-00-P2	15 - 1	4P7-F3843-00	17 - 34	4S5-F5917-00	21 - 12
5WG-E2659-00	4 - 9	4S5-E4871-00	8 - 15	4KL-E5657-00	11 - 15	4S5-F1711-00-P7	15 - 1	4S5-F4110-10	18 - 1	4S5-F5919-00	21 - 11
5WG-E2668-00	4 - 10	5WG-E4876-11	8 - 19	4KL-E5659-00	10 - 22	4S0-F1753-00	18 - 3	4S5-F4112-00	18 - 4	4S5-F5921-01	21 - 8
5WG-E2669-00	4 - 2	5WG-E4883-10	8 - 21	5MH-E5673-00	10 - 21	5WY-F1753-00	18 - 14	4S0-F4135-00	18 - 20	4S5-F5924-01	21 - 13
5MH-E3300-21	5 - 1	5WG-E4884-10	8 - 25	4KL-E5687-00	10 - 13	4S5-F1773-00	15 - 11	5WG-F414A-00	18 - 13	4S5-F5925-00	21 - 14
4KL-E3324-00	2 - 4	4S5-E4885-00	8 - 30	4S5-E5789-00	9 - 44	5MH-F1780-01	26 - 12	1CC-F4170-00	18 - 22	4S5-F5937-00	21 - 9
5MH-E3325-10	5 - 2	4S5-E4901-10	7 - 1	4KL-E6111-00	11 - 1	4KL-F1796-01	26 - 13	18C-F4180-00	18 - 19	4S5-F5939-00	21 - 10
4KL-E3411-01	5 - 9	5WG-E4907-00	7 - 20	4KL-E6111-20	11 - 4	5WG-F1823-02	26 - 24	4S5-F4311-10	18 - 9	4S5-F6110-30	23 - 1
1CC-E3416-00	9 - 11	5WG-E490A-00	7 - 17	4KL-E6620-20	11 - 29	4S5-F2210-00	16 - 1	4S5-F4312-00	18 - 11	4S5-F6110-50	23 - 1

零件号码索引
NUMERICAL INDEX

零件号码 PART NO.	参照 号码	零件号码 PART NO.	参照 号码	零件号码 PART NO.	参照 号码	零件号码 PART NO.	参照 号码	零件号码 PART NO.	参照 号码	零件号码 PART NO.	参照 号码
5WG-F6113-00	23 - 2	5WG-H1952-10	35 - 5	4S5-H4743-00	33 - 10	4S5-X2610-J0-P8	27 - 1	90149-06108	18 - 7	90240-06804	25 - 36
4S5-F6145-01	27 - 4	5WG-H1960-00	35 - 2	4S5-H4772-00	33 - 18	4S5-X2610-J0-P9	27 - 1	90149-06827	25 - 17	90241-10801	19 - 5
5WG-F6199-00	25 - 11	4KL-H2100-01	35 - 9	4P7-H5130-20	33 - 3	4S5-X2748-F0-AL	25 - 25	90149-08814	21 - 2	90249-12806	23 - 18
4S5-F6234-10-P0	27 - 8	5WG-H2115-00	35 - 10	4KL-H5131-20	26 - 16	4S5-X2748-F0-P2	25 - 25	90153-06803	1 - 3	90280-03045	2 - 5
4S5-F6234-10-P1	27 - 8	4S5-H2121-00	25 - 8	5WY-H5540-41	35 - 6		25 - 25	90154-06004	25 - 41	90338-11820	6 - 17
4S5-F6234-10-P2	27 - 8	4S5-H2129-00	25 - 12	4S0-H5546-00	35 - 1	4S5-X2748-F0-P3	25 - 25	90154-06807	14 - 2	90340-12806	9 - 40
4S5-F6234-10-P3	27 - 8	4KL-H2151-10	35 - 12	4P7-H5550-01	28 - 1	4S5-X2748-F0-P7	25 - 25	90157-05029	25 - 40	90380-17234	10 - 17
4S0-F6240-00	23 - 7	4KL-H2170-10	35 - 11	1CC-H5700-00	35 - 7	4S5-X2748-F0-WL	25 - 25	90157-05812	34 - 2	90387-06160	26 - 28
4KL-F6241-20	23 - 6	4P7-H2310-00	36 - 4	4S5-H5752-10	36 - 6	4S5-X2748-H0-P8	25 - 25	90159-06812	26 - 22	90387-063F7	14 - 10
4P7-F6270-10	23 - 8	4KL-H2370-01	36 - 2	4KL-H5753-00	36 - 7	4S5-X2749-F0-AL	25 - 27	90159-06867	14 - 9	90387-068H6	15 - 10
4P7-F6280-10	27 - 10	4KL-H2372-00	36 - 3	3D9-W0041-02	24 - 2	4S5-X2749-F0-P2	25 - 27	90170-05302	3 - 10	90387-068J1	4 - 3
4P7-F6290-10	27 - 11	5MH-H2566-11	25 - 39	4S5-W0045-00	21 - 6		25 - 27	90170-06020	25 - 42	90387-068J2	8 - 29
4S5-F6301-00	23 - 10	4S5-H2590-20	35 - 16	4S5-W0047-00	21 - 5	4S5-X2749-F0-P3	25 - 27	90170-12011	11 - 19		18 - 24
4S5-F6351-01	23 - 14	4S5-H2590-30	35 - 16	4S5-W0048-01	21 - 7	4S5-X2749-F0-P7	25 - 27	90170-12181	28 - 7	90387-125J1	20 - 11
1CC-F6361-00	25 - 35	4S5-H3301-01	30 - 1	4S5-W0057-00	21 - 4	4S5-X2749-F0-WL	25 - 27	90176-08811	1 - 17	90387-12825	20 - 1
4KL-F637G-01	23 - 15	4S5-H3311-00	30 - 2	4S5-WE441-02	6 - 7	4S5-X2749-H0-P8	25 - 27	90179-06843	23 - 19	90401-10823	24 - 11
5MH-F637G-01	25 - 45		33 - 14	4S5-X2142-00	13 - 2	4S5-X2831-F0-AL	26 - 1	90179-08833	8 - 11	90430-06014	1 - 4
4S5-F7111-00	25 - 1	4S5-H331E-00	30 - 3	4S5-X2150-H0-P2	14 - 1	4S5-X2831-F0-P2	26 - 1	90179-14805	11 - 5	90430-08119	9 - 13
5WG-F7113-01	25 - 4	4S5-H332E-00	30 - 4	4S5-X2150-H0-P8	14 - 1	4S5-X2831-F0-P3	26 - 1	90179-25810	17 - 41	90446-13800	9 - 5
5MH-F7114-00	25 - 43	4S5-H3332-01	33 - 8	4S5-X2172-F0-AL	15 - 3	4S5-X2831-F0-P7	26 - 1	90183-05818	14 - 5	90462-10803	6 - 3
5WG-F7151-01	25 - 16	4S5-H3333-00	33 - 16	4S5-X2172-F0-P2	15 - 3	4S5-X2831-F0-WL	26 - 1		15 - 5	90464-08020	4 - 12
5WG-F7180-01	25 - 15	4S5-H333M-00	33 - 15	4S5-X2172-F0-P3	15 - 3	4S5-X2831-H0-P8	26 - 1		15 - 8	90464-12812	35 - 17
1CC-F7211-00	25 - 29	4S5-H3342-01	33 - 9	4S5-X2172-F0-P7	15 - 3	4S5-X2831-H0-P9	26 - 1		25 - 14	90464-20809	23 - 12
1CC-F7212-00	25 - 31	5VL-H3350-21	35 - 21	4S5-X2172-F0-WL	15 - 3	4S5-X2834-H0-P3	26 - 19		26 - 2		35 - 18
1CC-F7263-00	25 - 32	5WG-H3371-01	35 - 22	4S5-X2172-H0-P8	15 - 3	4S5-X2834-H0-P4	26 - 19		26 - 21	90464-23811	35 - 20
1CC-F7285-00	25 - 30	1CC-H3509-10	31 - 4	4S5-X2172-H0-P9	15 - 3	4S5-X3102-03	17 - 2		27 - 2	90465-13152	35 - 19
4S5-F7311-10	25 - 21	4S5-H3510-31	31 - 1	4S5-X2173-F0-AL	15 - 6	4S5-X3103-03	17 - 16		30 - 5	90467-08003	18 - 12
4KL-F7314-00	25 - 2	1CC-H3517-10	31 - 2	4S5-X2173-F0-P2	15 - 6	4S5-X3126-00	17 - 3		33 - 5		18 - 26
4S5-F7481-01	25 - 7	1CC-H353K-01	31 - 3	4S5-X2173-F0-P3	15 - 6	4S5-X3136-00	17 - 17	90185-14807	22 - 4	90467-08070	8 - 32
4S5-F7483-00	25 - 20	4S5-H3550-01	31 - 6	4S5-X2173-F0-P7	15 - 6	4P7-X8231-10	36 - 1	90201-053E0	36 - 9	90467-09006	18 - 10
4S5-F7483-10	25 - 20	4S0-H3836-00	35 - 8	4S5-X2173-F0-WL	15 - 6	4S5-X8250-13	35 - 13	90201-06078	8 - 17		18 - 17
4KL-F8100-01	19 - 16	5WY-H3912-20	34 - 1	4S5-X2173-H0-P8	15 - 6	90101-06046	22 - 13	90201-06814	8 - 9	90467-12802	6 - 18
4S5-F8312-01	26 - 4	4S0-H3922-10	34 - 9	4S5-X2173-H0-P9	15 - 6	90101-10809	16 - 3	90201-077F5	5 - 5		9 - 6
4S5-F8312-11	26 - 4	4S0-H3963-01	34 - 4	4S5-X2310-03	17 - 1	90105-05804	36 - 8	90201-08609	1 - 16		18 - 2
4S5-F8313-00	26 - 11	4S0-H3975-01	34 - 5	4S5-X247R-00	19 - 6	90105-08861	16 - 2	90201-108A3	10 - 4	90467-13804	1 - 27
4S5-F8345-00-P2	26 - 19	1CC-H3980-00	34 - 6	5WG-X2534-00	22 - 6	90105-10839	23 - 3	90201-108J9	24 - 12	90467-13817	6 - 12
4S5-F8345-00-P5	26 - 19	5MH-H3980-11	34 - 8	4S5-X2610-F0-AL	27 - 1	90109-06255	34 - 10	90201-12172	9 - 41	90467-16805	8 - 22
4KL-F8349-11	26 - 18	4S5-H4310-01	32 - 1	4S5-X2610-F0-P2	27 - 1	90109-06822	19 - 9	90201-156F8	12 - 3	90467-16808	8 - 26
4S5-F834J-00	26 - 9	4S5-H4312-01	32 - 4	4S5-X2610-F0-P3	27 - 1		26 - 8	90201-163G6	10 - 11	90480-12803	14 - 11
5MH-F834V-00	26 - 10	4S5-H4314-00	32 - 2	4S5-X2610-F0-P7	27 - 1		33 - 2	90201-163J6	10 - 14	90480-13398	26 - 27
4S5-F8371-00	26 - 15	4S5-H4347-00	32 - 3	4S5-X2610-F0-WL	27 - 1	90109-08836	25 - 22	90201-16809	11 - 13	90480-15801	8 - 16
4S5-F8372-00	26 - 20	4S5-H4378-00	32 - 5	4S5-X2610-G0-AL	27 - 1	90113-06804	1 - 6	90201-175F6	10 - 16	90480-30167	4 - 5
4S5-H1410-00	28 - 2	4S5-H4700-02	33 - 6	4S5-X2610-G0-P2	27 - 1	90116-08019	1 - 2	90201-17804	13 - 5	90501-10312	34 - 12
5WG-H1800-01	29 - 1	4S5-H4714-00	33 - 13	4S5-X2610-G0-P3	27 - 1	90116-08020	1 - 28	90201-20276	22 - 5	90501-16829	5 - 10
4KL-H1801-00	29 - 2	4S5-H4721-01	33 - 7	4S5-X2610-G0-P7	27 - 1		1 - 29	90202-05193	18 - 8	90501-16831	23 - 17
4KL-H1828-00	29 - 4	4S5-H4723-00	33 - 11	4S5-X2610-G0-WL	27 - 1	90119-06157	25 - 9	90202-15804	25 - 3	90506-12001	22 - 7
5WG-H183G-00	29 - 5	4S5-H4724-00	33 - 12	4S5-X2610-H0-P8	27 - 1	90119-068A3	14 - 4	90202-26142	17 - 42	90506-14803	25 - 34
5WG-H1940-30	35 - 4	4S5-H4726-00	33 - 17	4S5-X2610-H0-P9	27 - 1	90119-08864	19 - 15	90208-12050	11 - 16	90506-15001	22 - 8

零件号码索引
NUMERICAL INDEX

零件号码 PART NO.	参照 号码	零件号码 PART NO.	参照 号码	零件号码 PART NO.	参照 号码	零件号码 PART NO.	参照 号码	零件号码 PART NO.	参照 号码	零件号码 PART NO.	参照 号码
90506-20816	25 - 24	93306-302Y1	12 - 6	95812-10030	13 - 13	98902-06012	9 - 27				
90506-35820	25 - 6	93311-315X0	12 - 4	95812-10035	25 - 5	98902-06016	9 - 38				
90508-40838	10 - 14	93317-110Y4	10 - 2	97502-06525	29 - 7	98902-06020	9 - 35				
91312-06012	3 - 24	93450-14088	2 - 8	97522-06512	1 - 10	98980-06020	8 - 3				
91312-06016	3 - 22	93602-13832	5 - 4	97602-05212	35 - 14	99001-05600	5 - 6				
	28 - 3	93603-12833	5 - 3	97602-05216	27 - 7	99002-09600	25 - 33				
91312-06025	1 - 22	93604-12831	9 - 32	97602-06214	4 - 14	99009-17400	10 - 15				
	1 - 25	93900-00827	20 - 5	97602-06220	4 - 4		13 - 6				
91312-06035	9 - 23		22 - 2		6 - 14	99009-35700	10 - 9				
91312-06040	9 - 19	94135-10803	20 - 6	97602-06225	6 - 22	99530-10114	1 - 20				
91312-06050	8 - 18	94135-10804	22 - 3	97602-06335	28 - 8		1 - 21				
91312-06060	9 - 8	94568-E8088	3 - 16	97607-04208	7 - 24		9 - 18				
	9 - 24	94700-00876	1 - 18	97702-40512	26 - 14		9 - 22				
91312-06100	9 - 9	95022-10030	21 - 15	97702-50012	14 - 7	99530-12016	9 - 7				
91312-08030	10 - 19	95602-05100	34 - 3		15 - 2						
91402-20012	25 - 37	95602-05200	26 - 17		15 - 4						
91A11-07048	18 - 15		33 - 4		15 - 7						
92012-05010	23 - 13	95602-06100	34 - 11		25 - 10						
92012-06020	9 - 33	95602-08200	25 - 23		25 - 13						
92012-06025	24 - 9	95602-10200	13 - 9		25 - 26						
92902-06200	25 - 38		13 - 12		25 - 28						
92902-12100	28 - 6		23 - 4		26 - 7						
92902-12600	28 - 5	95602-12200	20 - 9		27 - 9						
93102-19808	9 - 30	95612-06625	1 - 5	97702-50016	14 - 6						
93102-22805	11 - 3	95702-06500	6 - 4		23 - 5						
93102-22817	9 - 10		8 - 20		26 - 3						
93102-26852	12 - 8		8 - 28		26 - 5						
93106-17806	20 - 8		18 - 23		27 - 3						
93210-07890	22 - 16		19 - 4		27 - 6						
93210-108J3	22 - 10		26 - 29		30 - 6						
93210-14104	9 - 15	95702-10500	16 - 4		31 - 5						
93210-15171	3 - 25		22 - 15		33 - 19						
93210-15639	13 - 4	95802-06010	19 - 11	97702-60020	32 - 6						
93210-25806	6 - 2		25 - 46	97702-60530	4 - 7						
93210-26668	29 - 6	95802-06012	8 - 24	97780-50512	27 - 5						
93210-34803	5 - 11		17 - 45	98502-03008	34 - 7						
93210-448C2	1 - 15		17 - 47	98502-05010	23 - 11						
93210-55669	29 - 3		17 - 49	98502-05012	19 - 13						
93210-71462	1 - 12		17 - 51		25 - 19						
93211-028A9	9 - 31		26 - 26	98502-06010	35 - 23						
93306-003X8	10 - 8	95802-06014	13 - 15	98502-06012	10 - 6						
93306-201X4	20 - 4		18 - 16		23 - 16						
93306-203Y0	11 - 6	95802-06020	15 - 9	98502-06016	35 - 15						
93306-204Y4	12 - 7	95802-10014	25 - 44	98502-06018	36 - 5						
93306-204YN	11 - 2	95812-08016	3 - 15	98502-06020	1 - 13						
93306-205XY	2 - 2		9 - 12	98502-06025	35 - 3						
93306-301XJ	20 - 3	95812-08035	8 - 13	98507-05020	23 - 9						
93306-301Y1	12 - 2	95812-08050	8 - 12	98702-06020	5 - 8						

雅马哈纯正机油大集结



YAMALUBE®

纯正机油

品质保证! 动力之源!

请经销YAMALUBE纯正
机油!



90793-AC421-T1
90793-AC421-G1
SAE 10W-40 (1L)
高等级/通用



90793-AC432-00
SAE 10W-30 (1L)
通用机油



90793-AC423-T2
90793-AC423-G2
SAE 20W-40 (1L)
通用机油



90793-AC427-T1
90793-AC427-G1
SAE 10W-40 (0.8L)
弯梁车专用



90793-AC426-T1
SAE 5W-30 (1L)
冬季专用/通用



90793-AC434-00
SAE 10W-30 (0.8L)
弯梁车专用



90793-AC423-P1
SAE 20W-40 (1L)
通用机油



90793-AC404
GEAR (0.13L)
齿轮油
踏板车专用

友情提示: 磨合期后, 建议每1500KM更换一次机油(可根据实际使用状况减少里程数)。并清洗机油滤网。